

**SECTION A-A**

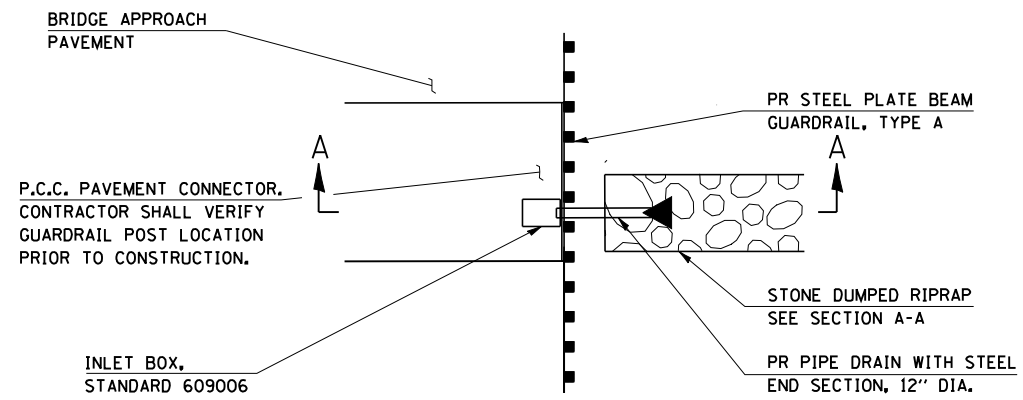

**PLAN**

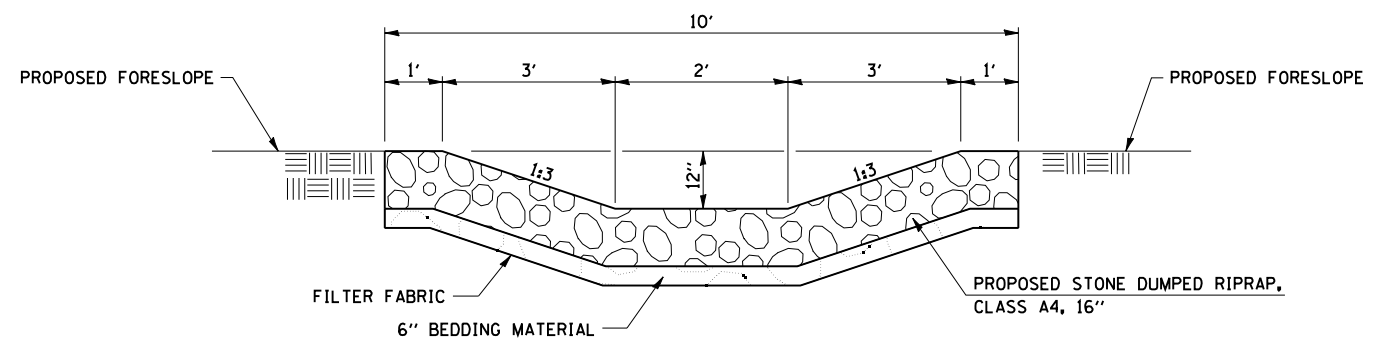

**SECTION B-B**

**NOTE:**  
SEE STD 609009 FOR DETAILS NOT SHOWN.