

WING WALL ELEVATION

SECTION B-B

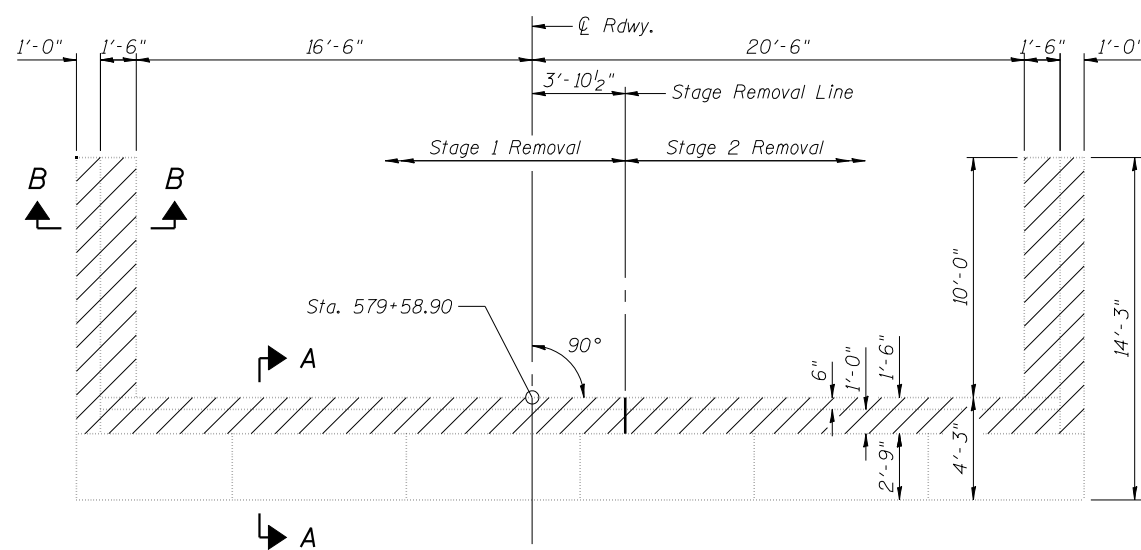

PLAN - EAST ABUTMENTS
 S.N. 054-0057 NB SHOWN
 S.N. 054-0058 SB SIMILAR

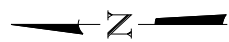
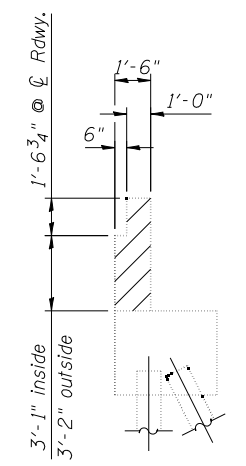

SECTION A-A

**TWO ABUTMENTS
 BILL OF MATERIAL**

Item	Unit	Total
Concrete Removal	Cu. Yd.	39.5

NOTE

Plan elevations relative to the existing structure have been taken from existing plans and reduced by 0.44 feet to match benchmark datum.



JOB = 2276.3
 FILE = 0540057_0058-EastAbutRem.dgn
 DATE = 2/11/2013

DESIGNED - AAN
 CHECKED - MDC
 DRAWN - SJS
 CHECKED - MDC

REVISED -
 REVISED -
 REVISED -
 REVISED -

**STATE OF ILLINOIS
 DEPARTMENT OF TRANSPORTATION**

**EAST ABUTMENTS CONCRETE REMOVAL
 STRUCTURE NO. 054-0057 (NB) & 054-0058 (SB)**

SHEET NO. 21 OF 31 SHEETS

F.A.I. RTE.	SECTION	COUNTY	TOTAL SHEETS	SHEET NO.
55	D6 LOGAN CO BR 2011-1	LOGAN	429	220
				CONTRACT NO. 72E11

ILLINOIS FED. AID PROJECT