

PAVEMENT MARKING LEGEND

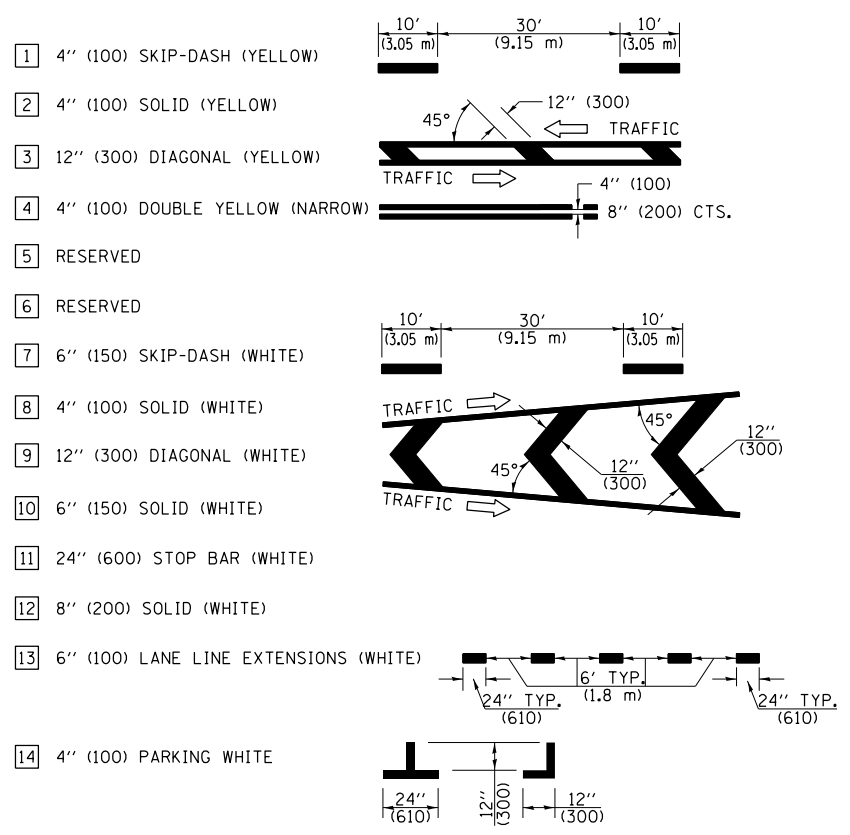

* REDUCE TO 40 FEET (12.2 METERS) SPACING ON CURVES WHERE ADVISORY SPEEDS ARE 10 MPH (15 km/h) LOWER THAN POSTED SPEEDS.

** DOUBLE LANE LINE MARKERS SHALL BE SPECIFIED AND SPACED AS SHOWN IN HIGHWAY STANDARD 781001 FOR MULTI-LANE DIVIDED AND UNDIVIDED HIGHWAYS.

GENERAL NOTES

- Ⓑ TURN ARROW PAIRS SHALL BE PLACED AT 250' (75 m) INTERVALS AND SHALL BE EVENLY SPACED BETWEEN BOTH ENDS OF THE BIDIRECTIONAL LEFT TURN LANE. USE A MINIMUM OF TWO PAIRS PER BLOCK.
- Ⓒ THE SOLID YELLOW PAVEMENT MARKINGS [2] SHOULD GENERALLY START OR END NEAR THE RADIUS POINT OF EACH STREET RETURN EXCEPT WHERE ONE OR BOTH ENDS WOULD INCLUDE STOP BARS.
- Ⓓ THE SKIP-DASH PAVEMENT MARKINGS [1] OR [7] SHOULD BE CENTERED BETWEEN BOTH ENDS OF EACH CITY BLOCK AND SHALL BE PLACED SO THEY LINE UP ACROSS FROM EACH OTHER.
- Ⓔ USE LARGE ARROW SIZE FOR BOTH RURAL AND URBAN LOCATIONS. (SEE LAST PAGE OF SECTION 780x FOR SYMBOLS TABLE)

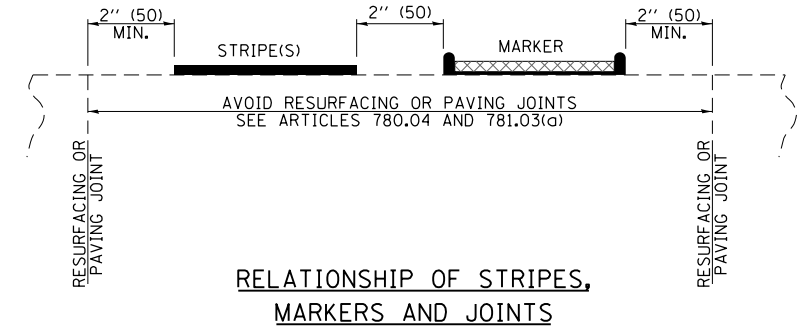

RELATIONSHIP OF STRIPES, MARKERS AND JOINTS

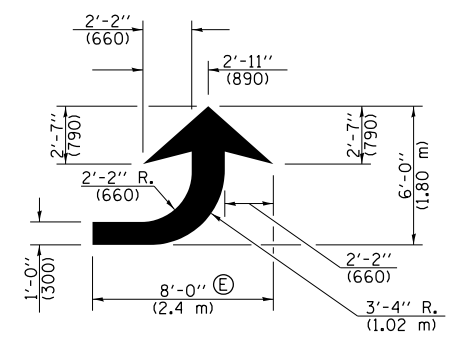

LEFT ARROW
REVERSE FOR RIGHT ARROW
AREA = 15.6 SQ. FT. (1.47 m²)
(WHITE)

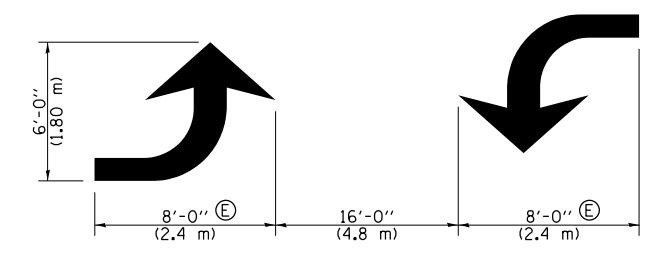

TYPICAL DOUBLE TURN ARROWS (WHITE)

NOT TO SCALE

Note: All dimensions are in INCHES (millimeters) unless otherwise shown.

FILE NAME =	USER NAME = steffenmk	DESIGNED -	REVISED -
ei:\pw\work\p\midot\steffenmk\d0249325\d74511-shit-details.dgn		DRAWN -	REVISED -
	PLOT SCALE = 40.0000' / in.	CHECKED -	REVISED -
	PLOT DATE = 10/2/2012	DATE -	REVISED -

**STATE OF ILLINOIS
DEPARTMENT OF TRANSPORTATION**

**PAVEMENT MARKING AND RAISED REFLECTIVE PAVEMENT MARKERS
(RURAL & URBAN APPLICATIONS)**

SCALE: NA SHEET NO. 2 OF 4 SHEETS STA. TO STA.

DISTRICT 7 DETAIL NO. 78000001				
F.A.P. RTE.	SECTION	COUNTY	TOTAL SHEETS	SHEET NO.
824	(19,20)RS-4	COLES	56	54
CONTRACT NO. 74511				
ILLINOIS FED. AID PROJECT				