

RELOCATED IL ROUTE 3 - SUPERELEVATION RIGHT

STA. 637+98.48 TO STA. 641+50.00

SUPERELEVATION	END N.C. STATION	S.E. 1.5% STATION	BEGIN FULL S.E. STATION	END FULL S.E. STATION	S.E. 1.5% STATION	BEGIN N.C. STATION
6.00%	636+22.32	636+58.32	638+02.32	645+32.35	646+76.35	647+12.35

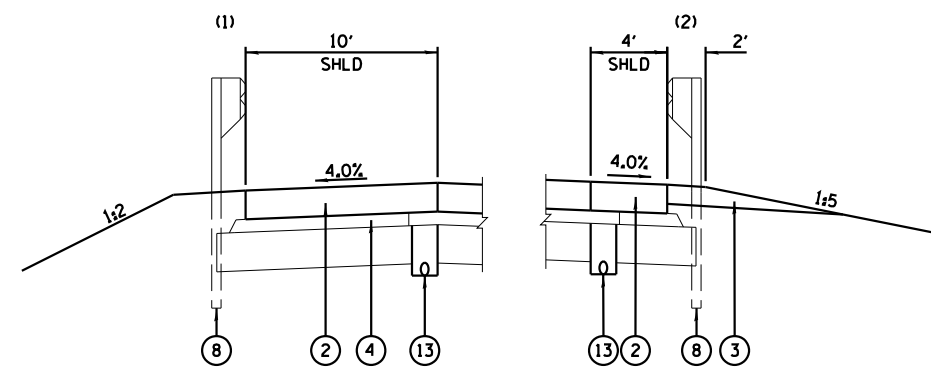

DETAIL AT GUARDRAIL (LT)

(1) STA. 637+36.18 TO STA. 1668+15.65
 (2) STA. 1654+67.86 TO STA. 1662+48.57

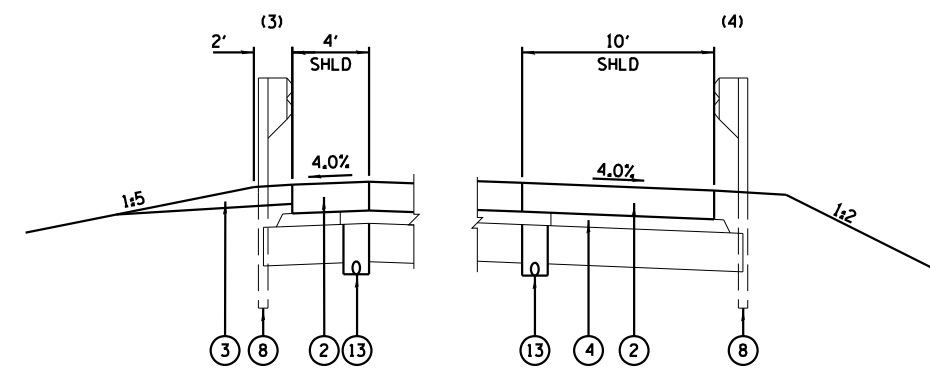

DETAIL AT GUARDRAIL (RT)

(3) STA. 645+62.77 TO STA. 1662+48.57
 (4) STA. 644+19.89 TO STA. 1668+15.65

- PROPOSED LEGEND
- ① PORTLAND CEMENT CONCRETE PAVEMENT 10 1/4" (JOINTED)
 - ② PORTLAND CEMENT CONCRETE SHOULDERS 10 1/4"
 - ③ AGGREGATE SHOULDERS, TYPE B 6" & VARIES
 - ④ STABILIZED SUBBASE - CEMENT AGGREGATE MIXTURE II, 4"
 - ⑤ PROCESSING MODIFIED SOIL (LIME) SUBGRADE 12"
 - ⑥ SUBBASE GRANULAR MATERIAL, TYPE C
 - ⑦ SEEDING, (EITHER CLASS 2A OR CLASS 3A)
 - ⑧ STEEL PLATE BEAM GUARDRAIL, TYPE A
 - ⑨ COMBINATION CONCRETE CURB AND GUTTER, TYPE B-6.24
 - ⑩ HOT-MIX ASPHALT SURFACE COURSE, MIX C, N50, 1 3/4"
 - ⑪ HOT-MIX ASPHALT BINDER COURSE, IL 19.0 FG N50, 2 1/4"
 - ⑫ AGGREGATE BASE COURSE, TYPE A, 8"
 - ⑬ PIPE UNDERDRAINS 4"

PGL = PROFILE GRADE LINE



USER NAME = \$USER*	DESIGNED - JJO	REVISED -
	DRAWN - JJO	REVISED -
PLOT SCALE = \$SCALE*	CHECKED - PJM	REVISED -
PLOT DATE = \$DATE*	DATE - 03/20/13	REVISED -

STATE OF ILLINOIS
DEPARTMENT OF TRANSPORTATION

RELOCATED IL ROUTE 3
TYPICAL SECTIONS

SCALE: SHEET NO. OF SHEETS STA. TO STA.

F.A.P. RTE.	SECTION	COUNTY	TOTAL SHEETS	SHEET NO.
788	520-1-2	ST. CLAIR	142	15
CONTRACT NO. 76850				
ILLINOIS FED. AID PROJECT				