

IL 100
MM 0.00 TO 5.65

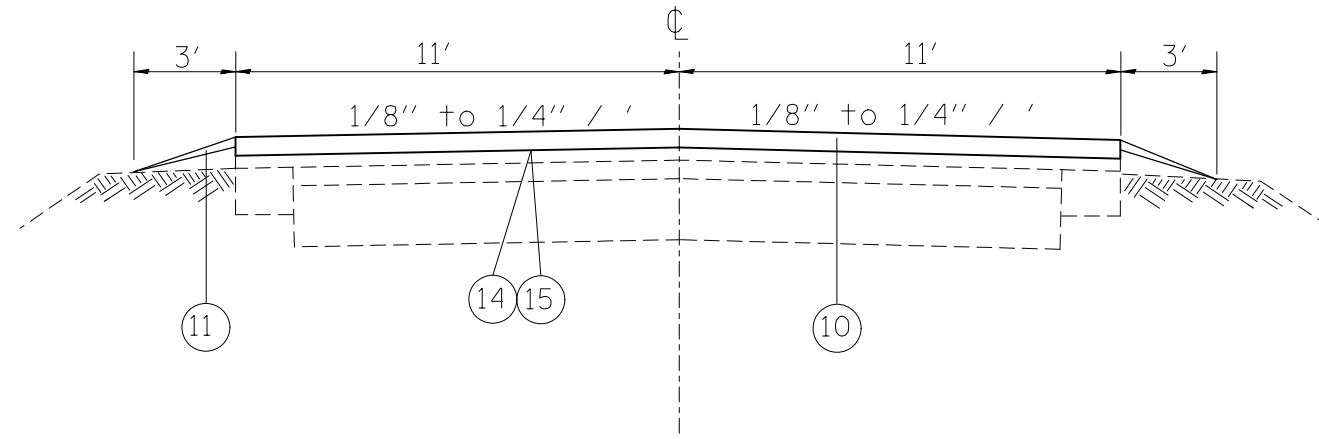

IL 100
MM 5.65 TO 14.37

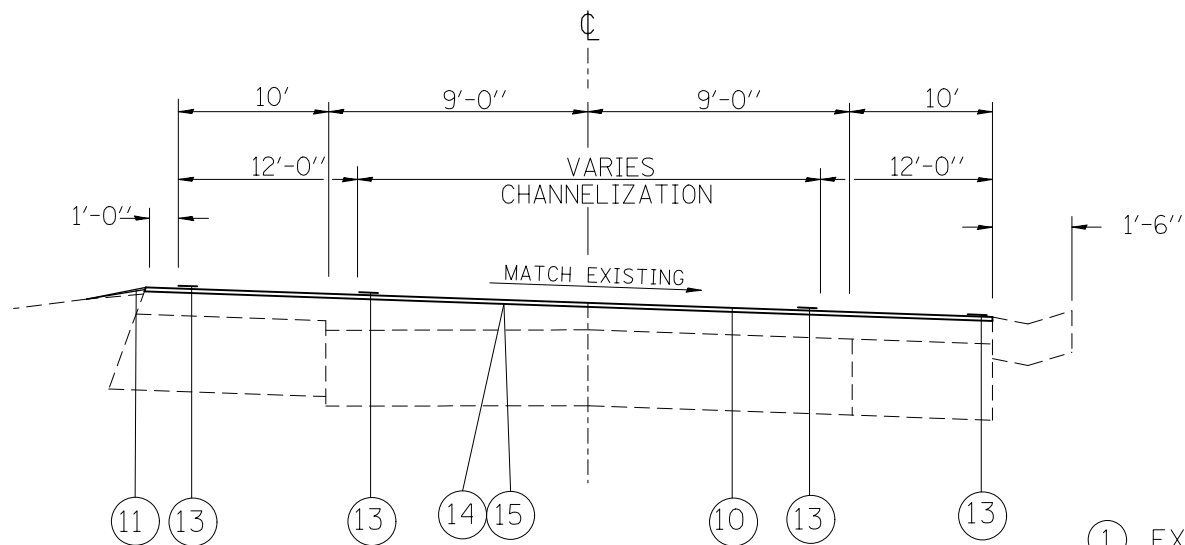

IL 100 - MM 14.37 TO 14.385 =
IL 16 - STA. 654+68.24 TO 655+50

IL 16 - STA. 653+50 TO 654+68.24

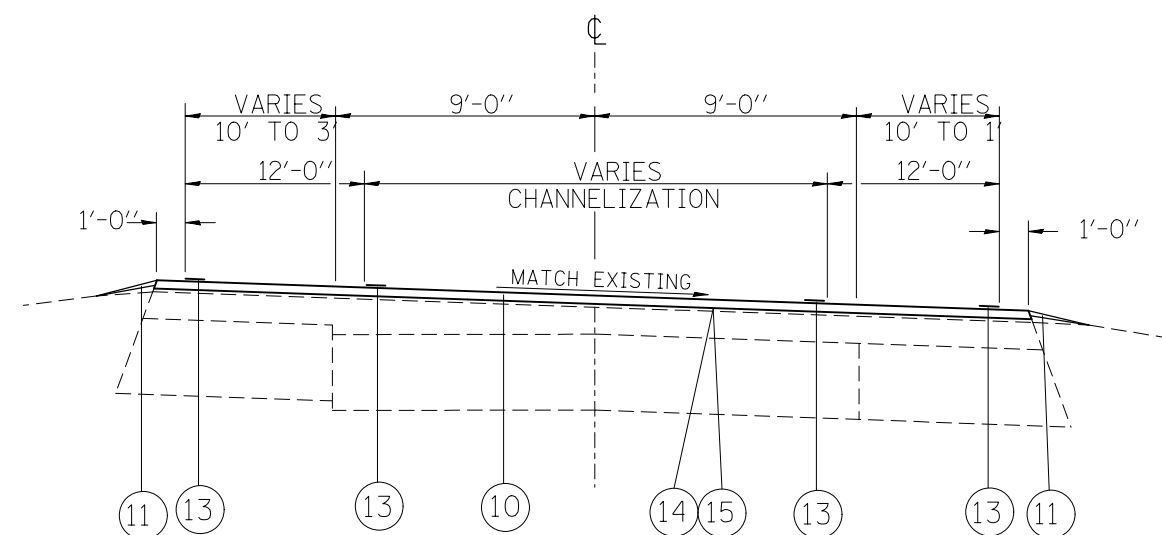

IL 100 - MM 14.385 TO 14.508 =
IL 16 - STA. 655+50 TO 662+00

- ① EXIST. AGG. BASE, 6"
- ② EXIST. RESURFACING
- ③ EXIST. CONCRETE PAVEMENT 9-6-9
- ④ EXIST. BASE COURSE WIDENING, 8"
- ⑤ EXIST. AGG. BASE COURSE, TYPE A, 10"
- ⑥ EXIST. PCC GUTTER, TYPE B
- ⑦ EXIST. AGG. SHOULDER WEDGE
- ⑧ EXIST. CAPE SEAL
- ⑨ EXIST. PAVEMENT MARKING - LINE 4"
- ⑩ PROP. HMA SURFACE COURSE, MIX C, 2 1/4"
- ⑪ PROP. AGGREGATE WEDGE SHOULDER
- ⑫ PROP. HMA SHOULDERS, 2 1/4"
- ⑬ PROP. PAVEMENT MARKING - LINE 4"
- ⑭ PROP. BITUMINOUS MATERIALS (PRIME COAT)
- ⑮ PROP. AGGREGATE (PRIME COAT)

LOCATIONS OF SAFETY SHOULDERS ARE SPORADIC THROUGHOUT THE PROJECT LIMITS AND ARE NOT SHOWN ON THE TYPICAL SECTIONS.

FILE NAME =	USER NAME = conoverpj	DESIGNED -	REVISED -
et:\pwork\pwork\conoverpj\d0280257\d076f24-sht-typical.dgn		DRAWN -	REVISED -
	PLOT SCALE = 100.0000' / 1in.	CHECKED -	REVISED -
	PLOT DATE = 3/22/2013	DATE -	REVISED -

STATE OF ILLINOIS
DEPARTMENT OF TRANSPORTATION

PROPOSED TYPICAL SECTIONS

SCALE: SHEET NO. 1 OF 2 SHEETS STA. TO STA.

F.A.P. RTE.	SECTION	COUNTY	TOTAL SHEETS	SHEET NO.
304	(6,4,2)RS-3	JERSEY	52	8
CONTRACT NO. 76F24				
FED. ROAD DIST. NO. ILLINOIS FED. AID PROJECT				