

METAL SHELL PILE TABLE

Designation and outside diameter	Wall thickness t	Weight per foot (Lbs./ft.)	Inside volume (yd. ³ /ft.)
PP12	0.179"	22.60	0.0274
PP12	0.250"	31.37	0.0267
PP14	0.250"	36.71	0.0368
PP14	0.312"	45.61	0.0361

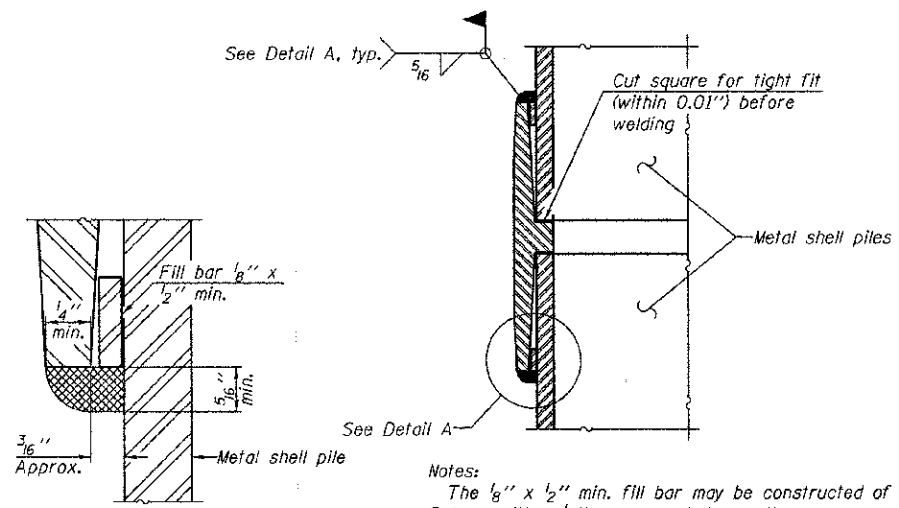

DETAIL A

WELDED COMMERCIAL SPLICE

Notes:
 The 1/8" x 1/2" min. fill bar may be constructed of 2 bars with a 1/8" max. gap between them.
 Pile segments shall be driven to solid contact with splicer before welding.

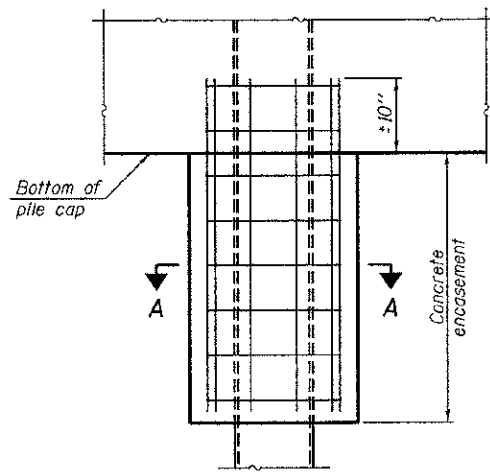

ELEVATION

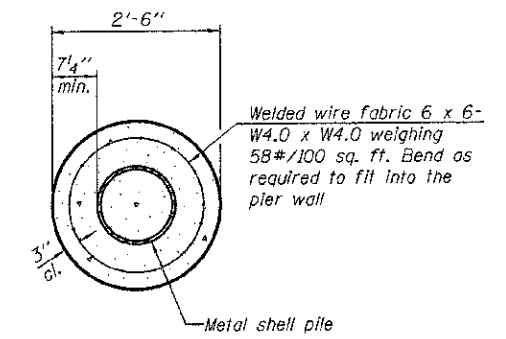

SECTION A-A

Note:
 Forms for encasement may be omitted when soil conditions permit.

CONCRETE ENCASEMENT AT PIERS

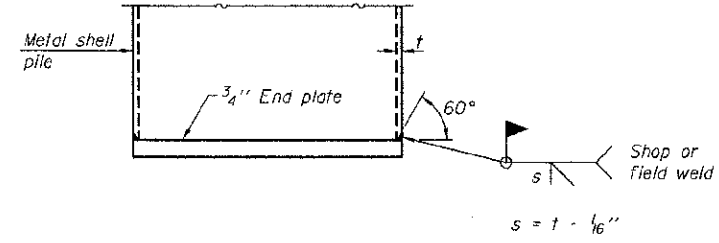

END PLATE ATTACHMENT

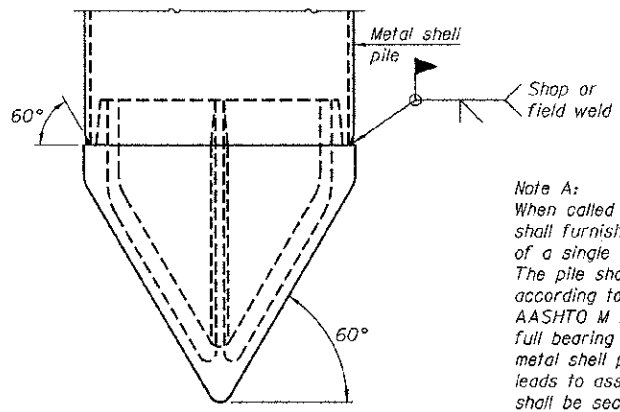

METAL SHELL PILE SHOE ATTACHMENT

(See Note A)

Note A:
 When called for on the plans, the Contractor shall furnish metal shell pile shoes consisting of a single piece conical pile point as shown. The pile shoes shall be cast in one piece steel according to either ASTM A 148 Grade 90-60 or AASHTO M 103 Grade 65-35 and shall provide full bearing over the full circumference of the metal shell pile. The pile shoe shall have tapered leads to assure proper alignment and fitting and shall be secured to the pile with a circumferential weld.

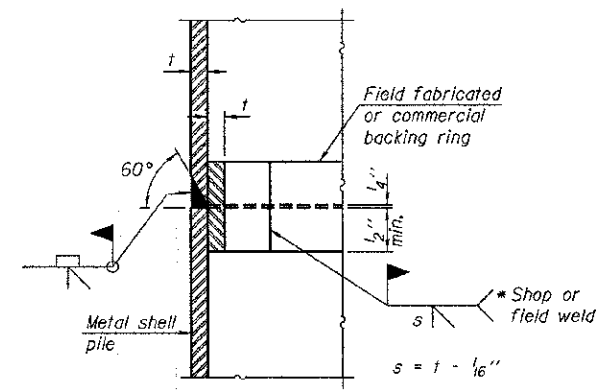

COMPLETE PENETRATION WELD SPLICE

* Field fabricated backing ring may be made from pile shell by removing segment to allow reducing circumference and vertically rejoin with partial joint penetration weld.

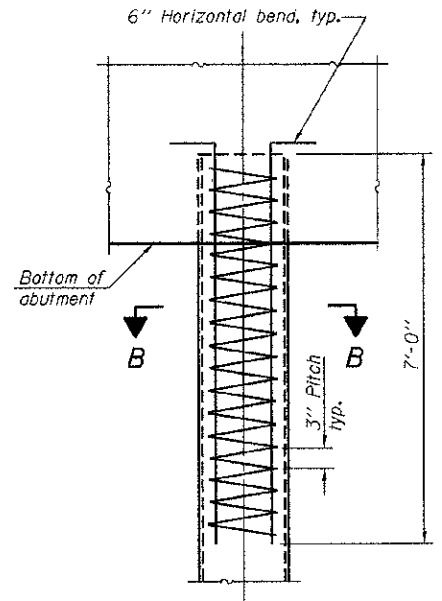

ELEVATION

METAL SHELL REINFORCEMENT AT ABUTMENTS

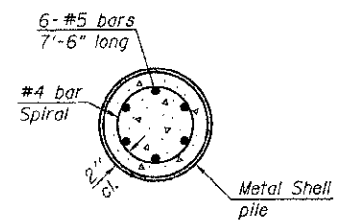

SECTION B-B

Note:
 The metal shell piles shall be according to ASTM A 252 Grade 3.

F-MS 1-27-12

FILE NAME * #FILE#	USER NAME *	DESIGNED - D.W.T.	REVISED -
HAMPTON, LENZINI AND RENWICK, INC.		CHECKED - S.W.M.	REVISED -
3003 STEVENSON DRIVE SUITE 307 SPRINGFIELD, ILLINOIS 62763		DRAWN - R.D.H.	REVISED -
ILLINOIS PROFESSIONAL DESIGN FIRM LSJ/PW/RE/COMD 154/08/06/09		CHECKED - D.A.B.	REVISED -

STATE OF ILLINOIS
 RICHLAND COUNTY HIGHWAY DEPARTMENT

METAL SHELL PILE DETAILS
 STRUCTURE NO. 080-3221

SHEET NO. 7 OF 9 SHEETS

F.A.S.	SECTION	COUNTY	TOTAL SHEETS	SHEET NO.
1722	11-00118-00-BR	RICHLAND	16	11
CONTRACT NO. 95705				
ILLINOIS FED. AID PROJECT				