

STATE OF ILLINOIS  
DEPARTMENT OF TRANSPORTATION

F.A.I. RTE.	SECTION	COUNTY	TOTAL SHEETS	SHEET NO.
55	(84-3HB-9)BDR	SANGAMON	18	1
		ILLINOIS	CONTRACT NO. 72912	

FOR INDEX OF SHEETS, SEE SHEET NO. 2

# PROPOSED CONTRACT MAINTENANCE

FAI ROUTE 55 (I-55)  
SECTION (84-3HB-9)BDR  
PROJECT (STATE)  
BRIDGE DECK REPAIRS  
SANGAMON COUNTY

C-96-046-24

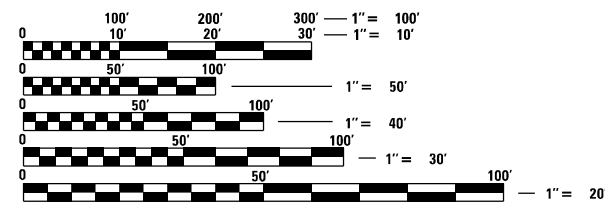
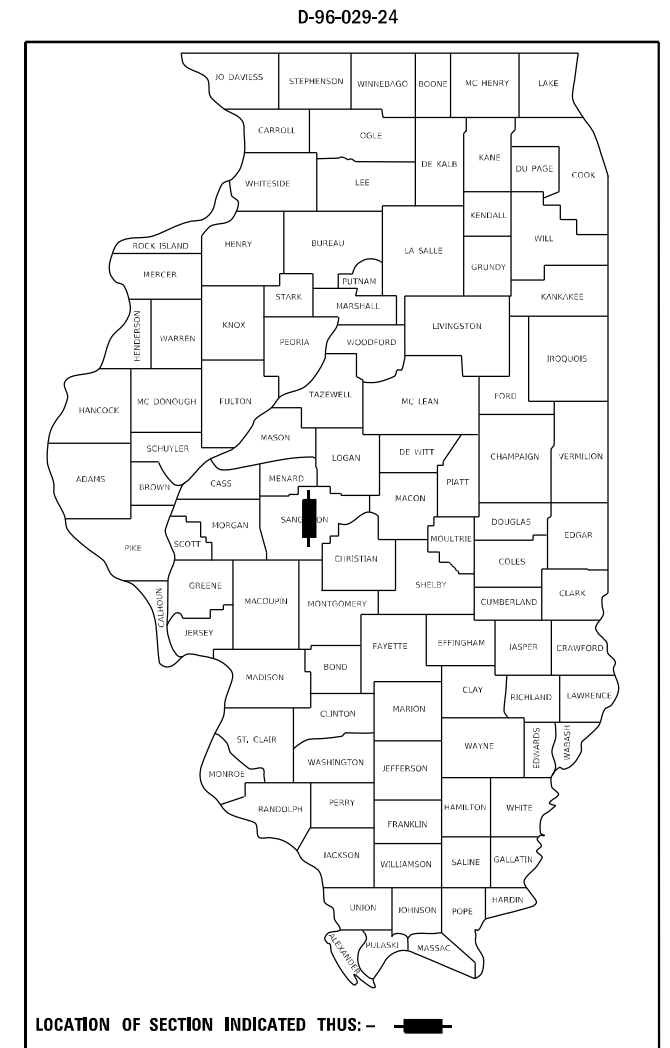

FULL SIZE PLANS HAVE BEEN PREPARED USING STANDARD ENGINEERING SCALES, REDUCED SIZED PLANS WILL NOT CONFORM TO STANDARD SCALES. IN MAKING MEASUREMENTS ON REDUCED PLANS, THE ABOVE SCALES MAY BE USED.

J.U.L.I.E.  
JOINT UTILITY LOCATION INFORMATION FOR EXCAVATORS  
1-800-892-0123  
OR 811

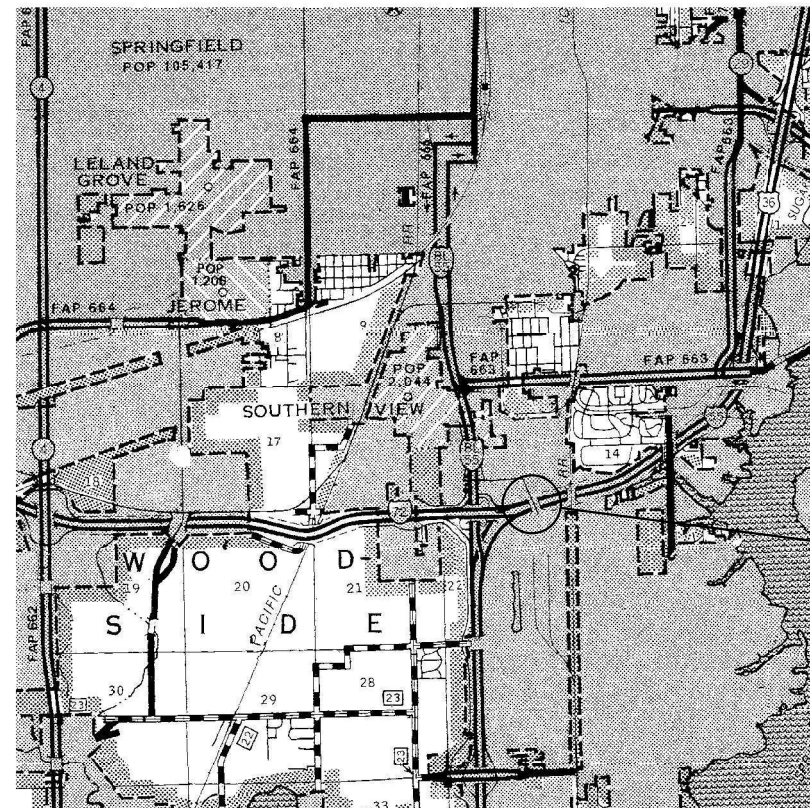

PROJECT LOCATION  
SN 084-0037  
11TH ST OVER I-55  
0.45 MI E OF 6TH ST

BRIDGE MAINTENANCE ENGINEER: BRANDON DUDLEY - (217) 785-9290

GROSS LENGTH = 361 FT. = 0.07 MILE  
NET LENGTH = 361 FT. = 0.07 MILE

CONTRACT NO. 72912

STATE OF ILLINOIS  
DEPARTMENT OF TRANSPORTATION

SUBMITTED March 26 2024

*July P. Meyer*  
REGIONAL ENGINEER

May 10, 2024 *Jack A. Etk*  
ENGINEER OF DESIGN AND ENVIRONMENT

May 10, 2024 *Stephen M. Smith*  
DIRECTOR OF HIGHWAYS PROJECT IMPLEMENTATION

PRINTED BY THE AUTHORITY  
OF THE STATE OF ILLINOIS

INDEX OF SHEETS

- 1 COVER SHEET
- 2 INDEX, STANDARDS, SIGNATURES, & GENERAL NOTES
- 3 SUMMARY OF QUANTITIES
- 4 STAGING PLAN
- 5-16 TRAFFIC CONTROL PLANS
- 17-18 BRIDGE PLANS



STANDARDS

- 000001-08
- 001001-02
- 001006
- 701101-05
- 701106-02
- 701400-12
- 701401-13
- 701606-10
- 701901-09

GENERAL NOTES:

AREAS OF DECK REPAIRS SHOWN ARE ESTIMATED. THE ENGINEER SHALL SHOW ACTUAL LOCATIONS ON AS-BUILT PLANS.

FULL DEPTH PATCHES SHALL BE COVERED WITH STEEL PLATES WHEN WORKERS ARE NOT PRESENT.

<b>STATE OF ILLINOIS DEPARTMENT OF TRANSPORTATION DIVISION OF HIGHWAYS DISTRICT 6</b>	
EXAMINED	March, 15 20 24
 ENGINEER OF OPERATIONS	
EXAMINED	March, 15 20 24
 ENGINEER OF PROJECT IMPLEMENTATION	
EXAMINED	March, 14 20 24
 ENGINEER OF PROGRAM DEVELOPMENT	

MODEL Path: S:\Roads\Bridges\Bridges\CAD\72912 - 0840037 Patching\Bridges.dgn

	USER NAME = Brandon.Dudley	DESIGNED -	REVISED -	<b>STATE OF ILLINOIS DEPARTMENT OF TRANSPORTATION</b>	<b>INDEX OF SHEETS, STANDARDS, GENERAL NOTES, &amp; SIGNATURES</b>			F.A.I. RTE.	SECTION	COUNTY	TOTAL SHEETS	SHEET NO.
		DRAWN -	REVISED -									
	PLOT SCALE = 100,0000 ' / in.	CHECKED -	REVISED -					55	(84-3HB-9)BDR	SANGAMON	18	2
	PLOT DATE = 3/19/2024	DATE -	REVISED -			SCALE:	SHEET	OF	SHEETS	STA.	TO	STA.



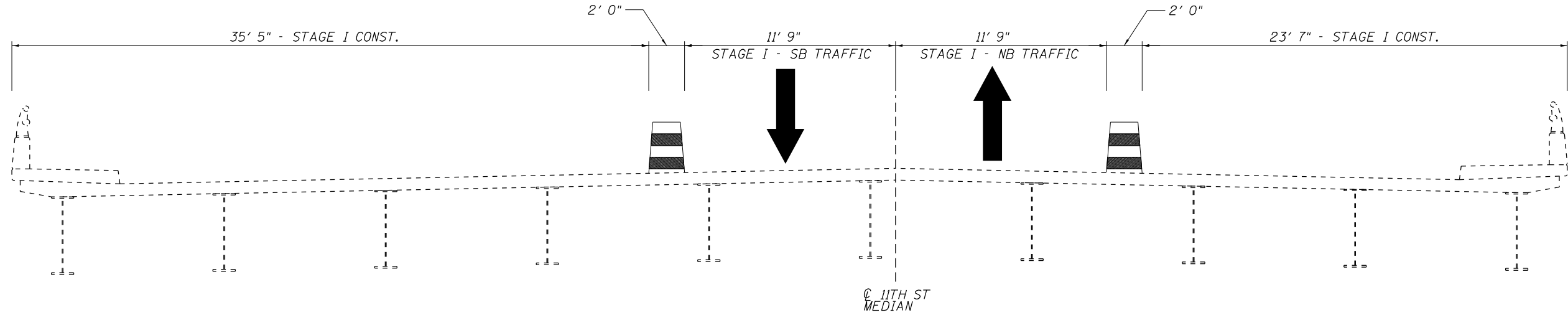

**STAGE I TRAFFIC - LOOKING NORTH**

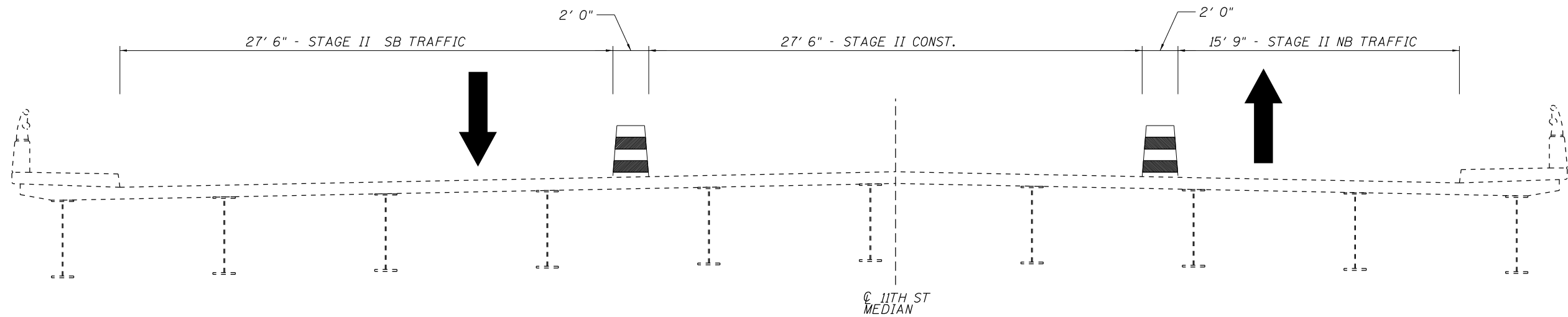

**STAGE II TRAFFIC - LOOKING NORTH**

MODEL: Default  
FILE NAME: S:\Addresses\Bridges\BDR\72912 - 0840037\_batching\plan\sheet.dgn

USER NAME = Brandon.Dudley	DESIGNED -	REVISED -
PLOT SCALE = 100,0000' / in.	DRAWN -	REVISED -
PLOT DATE = 3/19/2024	CHECKED -	REVISED -
	DATE -	REVISED -

**STATE OF ILLINOIS  
DEPARTMENT OF TRANSPORTATION**

**TRAFFIC STAGING DETAIL**



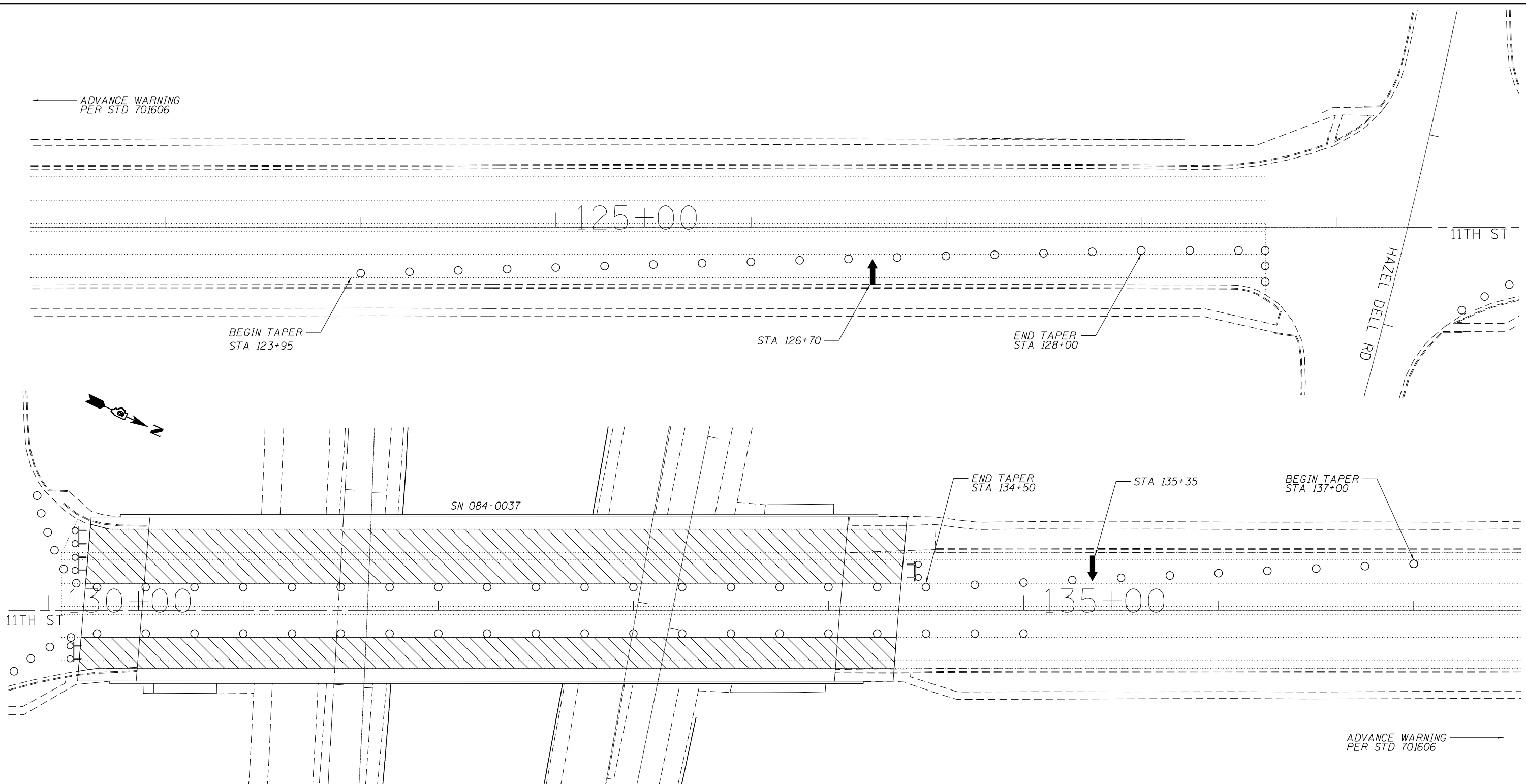

SCALE: SHEET OF SHEETS STA. TO STA.

F.A.I. RTE.	SECTION	COUNTY	TOTAL SHEETS	SHEET NO.
55	(84-3HB-9)BDR	SANGAMON	18	4
CONTRACT NO. 72912				
ILLINOIS FED. AID PROJECT				

← ADVANCE WARNING  
PER STD 701606

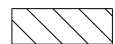

**SYMBOLS**

-  WORK AREA
-  TYPE II BARRICADE, DRUM,  
OR VERTICAL BARRICADE
-  ARROW BOARD
-  TY III BARRICADE W/  
LIGHTS & ROAD CLOSED SIGN

TRAFFIC CONTROL NOTES:

1. TRAFFIC CONTROL DEVICES NOT SHOWN IN THIS DETAIL SHALL BE PER STANDARD 701606.

MODEL: Default  
FILE NAME: S:\Roads\Bridges\Bridges\_CAD\72912 - 0840037\_patch\plan\sheet.dgn

USER NAME = Brandon.Dudley	DESIGNED -	REVISED -
PLOT SCALE = 100,0000' / in.	DRAWN -	REVISED -
PLOT DATE = 3/19/2024	CHECKED -	REVISED -
	DATE -	REVISED -

**STATE OF ILLINOIS  
DEPARTMENT OF TRANSPORTATION**

**TRAFFIC CONTROL PLAN  
11TH ST - STAGE I**

SCALE: SHEET OF SHEETS STA. TO STA.

F.A.I. RTE.	SECTION	COUNTY	TOTAL SHEETS	SHEET NO.
55	(84-3HB-9)BDR	SANGAMON	18	5
CONTRACT NO. 72912				
ILLINOIS FED. AID PROJECT				

← ADVANCE WARNING  
PER STD 701606

BEGIN TAPER  
STA 123+95

STA 126+70

125+00

11TH ST

HAZEL DELL RD

END TAPER  
STA 128+00



SN 084-0037

END TAPER  
STA 134+50

STA 135+35

BEGIN TAPER  
STA 137+00

11TH ST

130+00

135+00

→ ADVANCE WARNING  
PER STD 701606

**SYMBOLS**

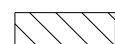

WORK AREA



TYPE II BARRICADE, DRUM,  
OR VERTICAL BARRICADE



ARROW BOARD



TY III BARRICADE W/  
FLASHING LIGHTS & ROAD CLOSED SIGN

**TRAFFIC CONTROL NOTES:**

1. TRAFFIC CONTROL DEVICES NOT SHOWN IN THIS DETAIL SHALL BE PER STANDARD 701606.

MODEL: Default  
FILE NAME: S:\Roads\Bridges\084\0037\0840037\_traffic\_control\0840037\_traffic\_control.dgn

USER NAME = Brandon.Dudley	DESIGNED -	REVISED -
	DRAWN -	REVISED -
PLOT SCALE = 100,0000' / in.	CHECKED -	REVISED -
PLOT DATE = 3/19/2024	DATE -	REVISED -

**STATE OF ILLINOIS  
DEPARTMENT OF TRANSPORTATION**

**TRAFFIC CONTROL PLAN  
11TH ST - STAGE II**

SCALE: SHEET OF SHEETS STA. TO STA.

F.A.I. RTE.	SECTION	COUNTY	TOTAL SHEETS	SHEET NO.
55	(84-3HB-9)BDR	SANGAMON	18	6
			CONTRACT NO. 72912	
		ILLINOIS FED. AID PROJECT		

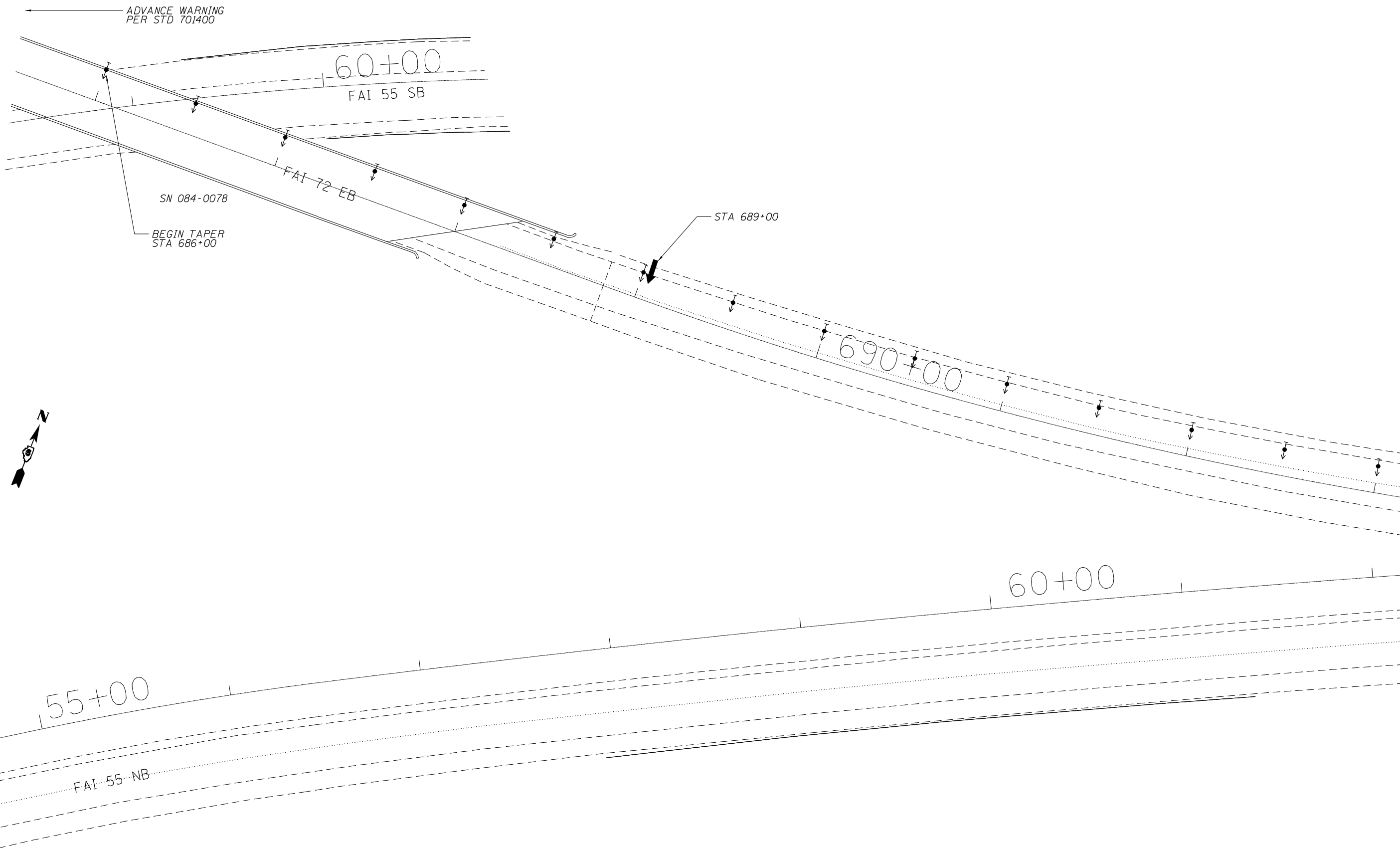

MODEL: Default  
 FILE NAME: S:\Roads\Bridges\Bridges\_CAD\72912 - 0840037 Matching\plan sheet.dgn

USER NAME = Brandon.Dudley	DESIGNED -	REVISED -
	DRAWN -	REVISED -
PLOT SCALE = 100,0000' / in.	CHECKED -	REVISED -
PLOT DATE = 3/19/2024	DATE -	REVISED -

**STATE OF ILLINOIS**  
**DEPARTMENT OF TRANSPORTATION**



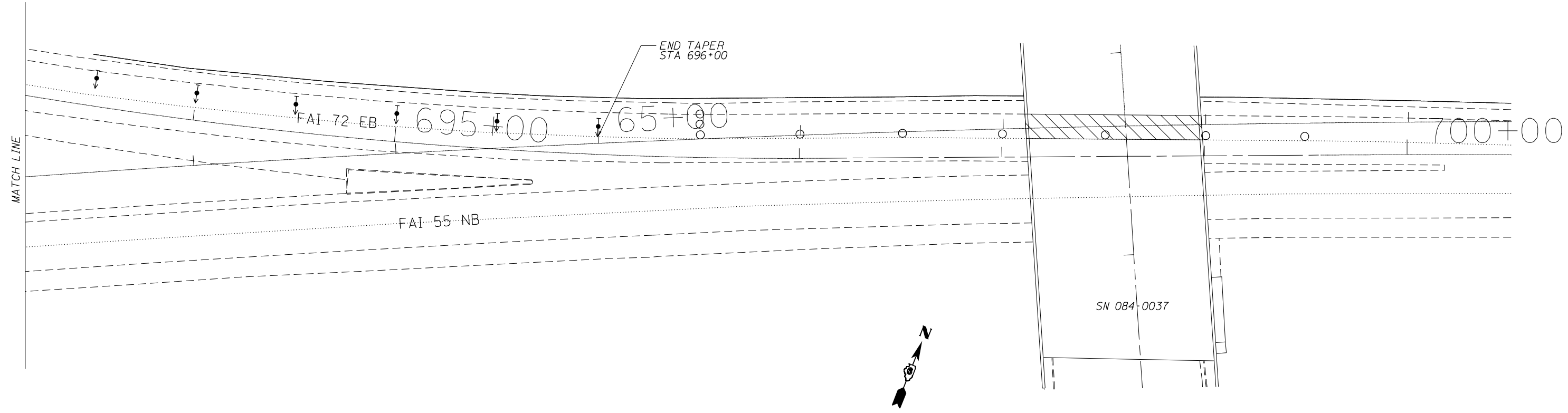

**TRAFFIC CONTROL PLAN**  
**I-72 EBPL CLOSURE**

SCALE: SHEET OF SHEETS STA. TO STA.

F.A.I. RTE.	SECTION	COUNTY	TOTAL SHEETS	SHEET NO.
55	(84-3HB-9)BDR	SANGAMON	18	7
CONTRACT NO. 72912				
ILLINOIS FED. AID PROJECT				



**SYMBOLS**

-  WORK AREA
-  TYPE II BARRICADE, DRUM, OR VERTICAL BARRICADE
-  ARROW BOARD
-  DIRECTION INDICATOR BARRICADE WITH STEADY BURN MONODIRECTIONAL LIGHT

TRAFFIC CONTROL NOTES:  
 1. TRAFFIC CONTROL DEVICES NOT SHOWN IN THIS DETAIL SHALL BE PER STANDARD 701400 & 701401.  
 2. I-55 NBDL SHALL NOT BE CLOSED CONCURRENTLY WITH I-72 EBPL.

MODEL: D:\p\h\...  
 FILE NAME: S:\Addresses\Bridges\I-72\72912 - 0840037 matching\plan sheet.dgn

USER NAME = Brandon.Dudley	DESIGNED -	REVISED -
PLOT SCALE = 100,0000' / in.	DRAWN -	REVISED -
PLOT DATE = 3/19/2024	CHECKED -	REVISED -
	DATE -	REVISED -

**STATE OF ILLINOIS**  
**DEPARTMENT OF TRANSPORTATION**

**TRAFFIC CONTROL PLAN**  
**I-72 EBPL CLOSURE**

SCALE: SHEET OF SHEETS STA. TO STA.

F.A.I. RTE.	SECTION	COUNTY	TOTAL SHEETS	SHEET NO.
55	(84-3HB-9)BDR	SANGAMON	18	8
CONTRACT NO. 72912				
ILLINOIS FED. AID PROJECT				



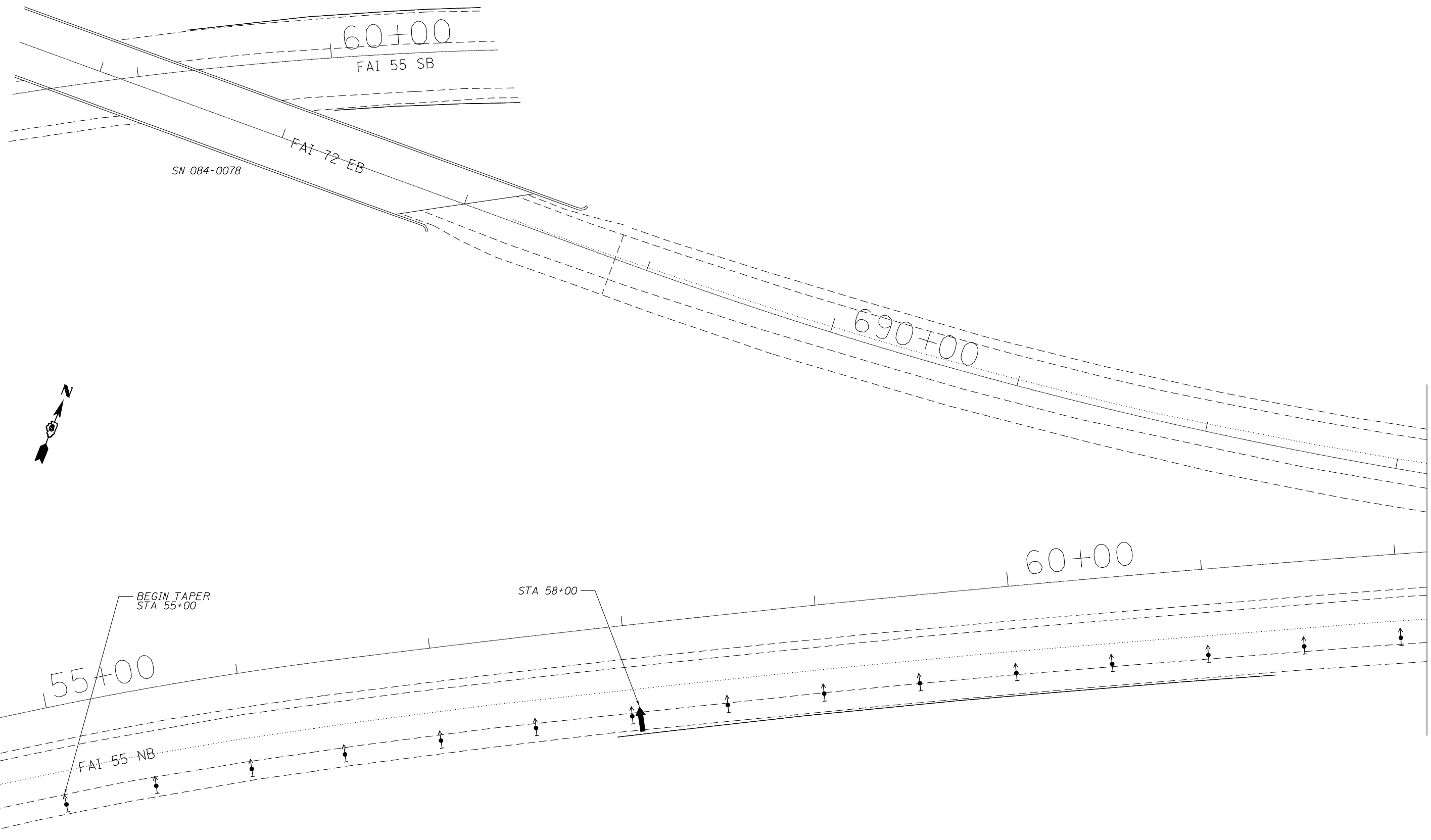

BEGIN TAPER  
STA 55+00

STA 58+00

55+00

60+00

690+00

FAI 55 NB

FAI 72 EB

60+00  
FAI 55 SB

SN 084-0078

← ADVANCE WARNING  
PER STD 701400

MATCH LINE

MODEL: D:\p\h\... FILE NAME: S:\p\h\... CAD: 72912 - 0840037 MATCHING: abnrcsheet.dgn

USER NAME = Brandon.Dudley	DESIGNED -	REVISED -
PLOT SCALE = 100,0000' / in.	DRAWN -	REVISED -
PLOT DATE = 3/19/2024	CHECKED -	REVISED -
	DATE -	REVISED -

**STATE OF ILLINOIS  
DEPARTMENT OF TRANSPORTATION**



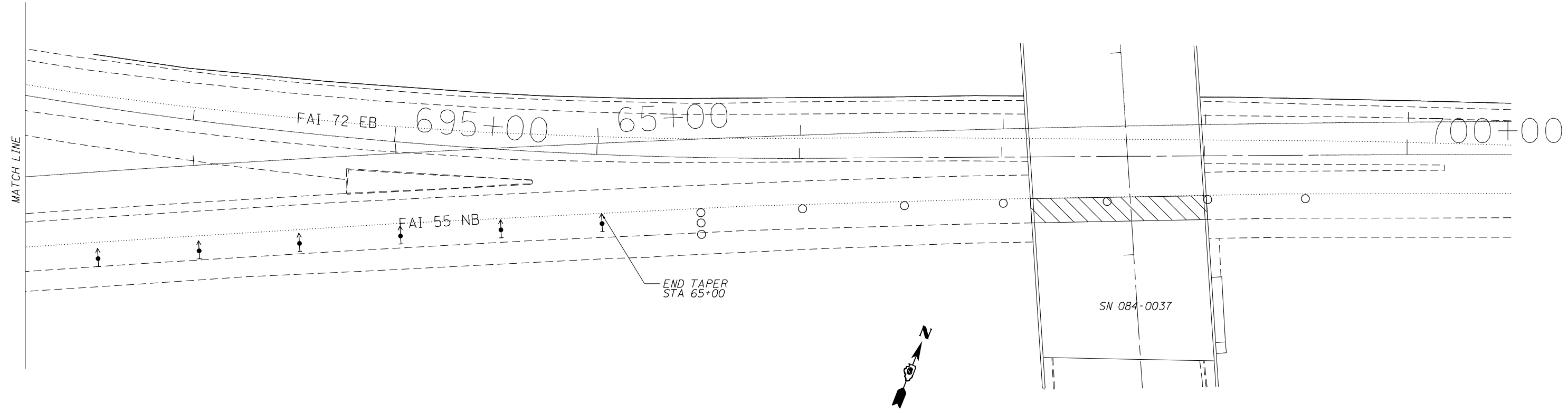

**TRAFFIC CONTROL PLAN  
I-55 NBDL CLOSURE**

SCALE: SHEET OF SHEETS STA. TO STA.

F.A.I. RTE.	SECTION	COUNTY	TOTAL SHEETS	SHEET NO.
55	(84-3HB-9)BDR	SANGAMON	18	9
ILLINOIS FED. AID PROJECT			CONTRACT NO. 72912	

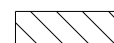

**SYMBOLS**

-  WORK AREA
-  TYPE II BARRICADE, DRUM, OR VERTICAL BARRICADE
-  ARROW BOARD
-  DIRECTION INDICATOR BARRICADE WITH STEADY BURN MONODIRECTIONAL LIGHT

TRAFFIC CONTROL NOTES:

1. TRAFFIC CONTROL DEVICES NOT SHOWN IN THIS DETAIL SHALL BE PER STANDARD 701400 & 701401.
2. I-55 NBDL SHALL NOT BE CLOSED CONCURRENTLY WITH I-72 EBPL.

MODEL: D:\p\h\...  
 FILE: 84-3HB-9\BDR...  
 USER: Brandon.Dudley  
 DATE: 3/19/2024

USER NAME = Brandon.Dudley	DESIGNED -	REVISED -
PLOT SCALE = 100,0000' / in.	DRAWN -	REVISED -
PLOT DATE = 3/19/2024	CHECKED -	REVISED -
	DATE -	REVISED -

**STATE OF ILLINOIS**  
**DEPARTMENT OF TRANSPORTATION**

**TRAFFIC CONTROL PLAN**  
**I-55 NBDL CLOSURE**

SCALE:	SHEET	OF	SHEETS	STA.	TO	STA.
--------	-------	----	--------	------	----	------

F.A.I. RTE.	SECTION	COUNTY	TOTAL SHEETS	SHEET NO.
55	(84-3HB-9)BDR	SANGAMON	18	10
CONTRACT NO. 72912				
ILLINOIS FED. AID PROJECT				

ADVANCE WARNING  
PER STD 701400

60+00  
FAI 55 SB

SN 084-0078

FAI 72 EB

BEGIN TAPER  
STA 686+00

STA 689+00

690+00



BEGIN TAPER  
STA 55+00

STA 58+00

60+00

55+00

FAI 55 NB

ADVANCE WARNING  
PER STD 701400

MATCH LINE

MODEL: D:\p\h\l  
FILE NAME: S:\\_Roads\Bridges\I-72\72912 - 0840037\atching\abrnsheet.dgn

USER NAME = Brandon.Dudley	DESIGNED -	REVISED -
PLOT SCALE = 100,0000' / in.	DRAWN -	REVISED -
PLOT DATE = 3/19/2024	CHECKED -	REVISED -
	DATE -	REVISED -

STATE OF ILLINOIS  
DEPARTMENT OF TRANSPORTATION



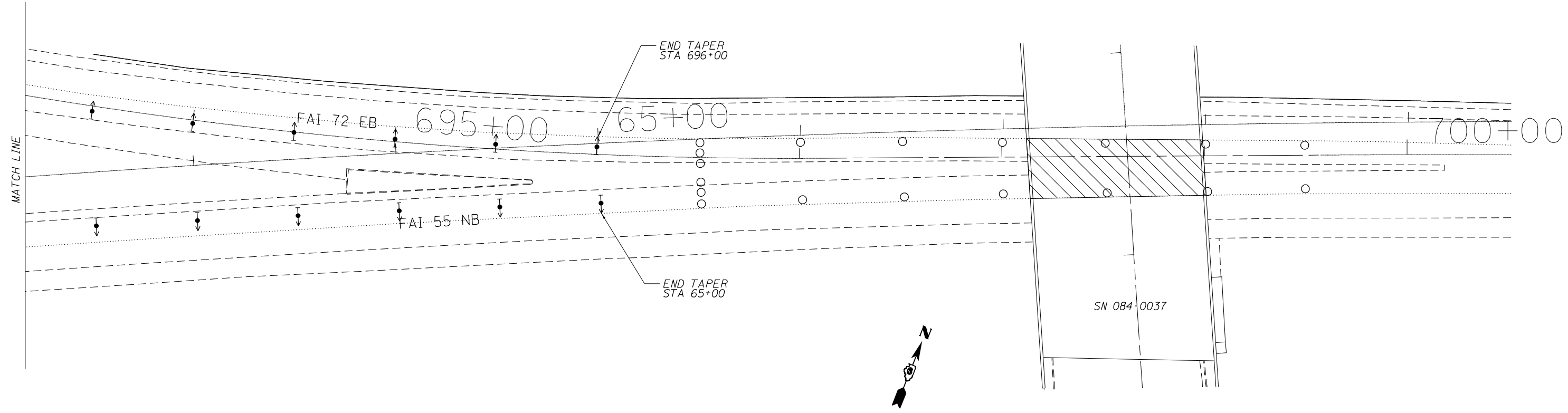

TRAFFIC CONTROL PLAN  
I-72 EBDL & I-55 NBPL CLOSURE

SCALE: SHEET OF SHEETS STA. TO STA.

F.A.I. RTE.	SECTION	COUNTY	TOTAL SHEETS	SHEET NO.
55	(84-3HB-9)BDR	SANGAMON	18	11
CONTRACT NO. 72912				
ILLINOIS FED. AID PROJECT				

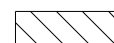

**SYMBOLS**

-  WORK AREA
-  TYPE II BARRICADE, DRUM, OR VERTICAL BARRICADE
-  ARROW BOARD
-  DIRECTION INDICATOR BARRICADE WITH STEADY BURN MONODIRECTIONAL LIGHT

TRAFFIC CONTROL NOTES:  
 1. TRAFFIC CONTROL DEVICES NOT SHOWN IN THIS DETAIL SHALL BE PER STANDARD 701400 & 701401.

MODEL: D:\p\h\...  
 FILE NAME: S:\p\h\...\_0840037\_matching\plan\sheet.dgn

USER NAME = Brandon.Dudley	DESIGNED -	REVISED -
	DRAWN -	REVISED -
PLOT SCALE = 100,0000' / in.	CHECKED -	REVISED -
PLOT DATE = 3/19/2024	DATE -	REVISED -

**STATE OF ILLINOIS  
 DEPARTMENT OF TRANSPORTATION**

<b>TRAFFIC CONTROL PLAN</b>			
<b>I-72 EBDL &amp; I-55 NBPL CLOSURE</b>			
SCALE:	SHEET	OF	SHEETS
	STA.	TO	STA.

F.A.I. RTE.	SECTION	COUNTY	TOTAL SHEETS	SHEET NO.
55	(84-3HB-9)BDR	SANGAMON	18	12
CONTRACT NO. 72912				
ILLINOIS FED. AID PROJECT				

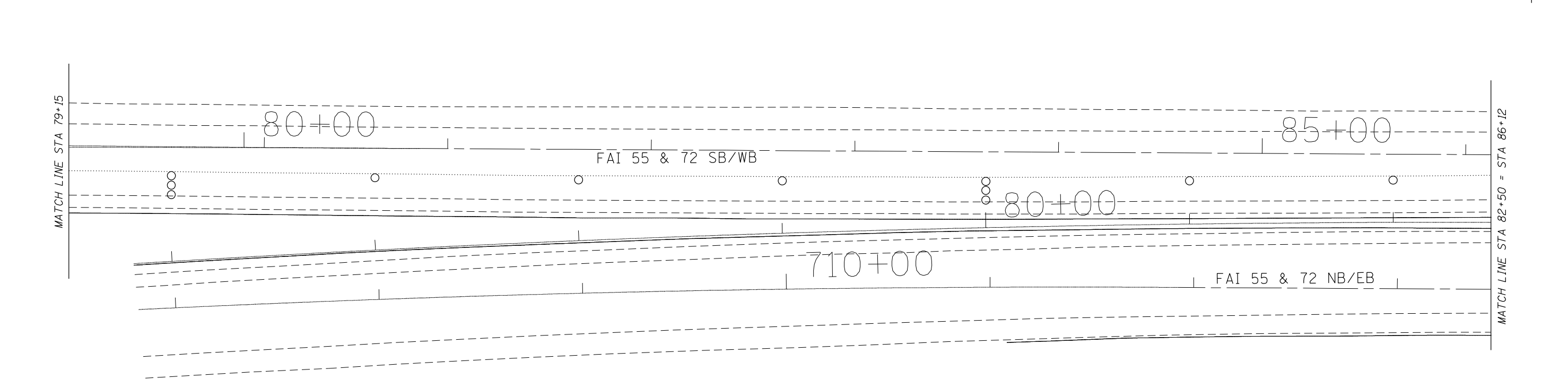
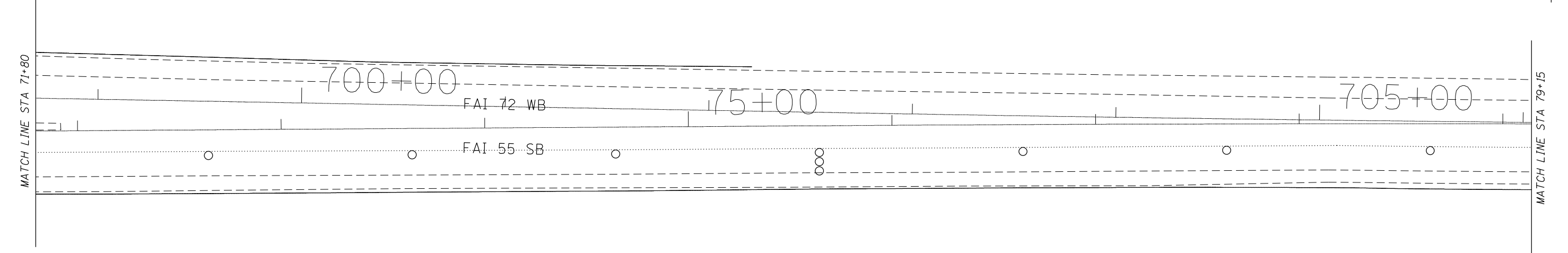
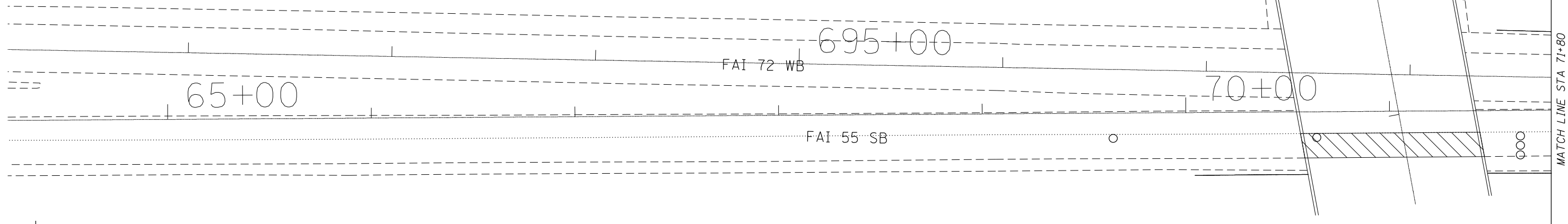
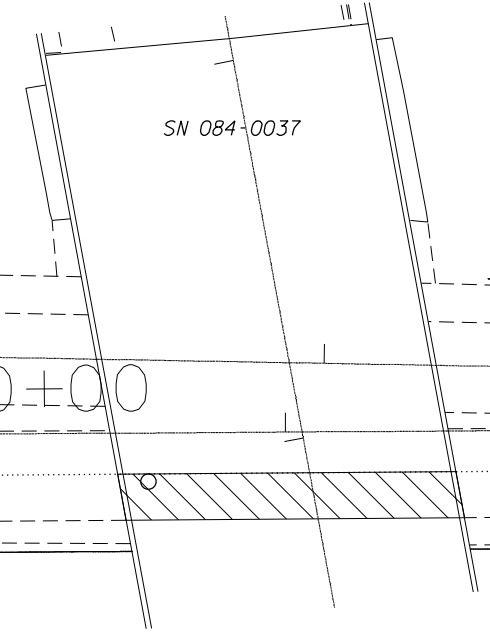

MODEL: Default  
 FILE NAME: S:\Addresses\Bridges\84-3HB-9\BDR\_CAD\72912 - 0840037 Traffic\plan\sheet.dgn

USER NAME = Brandon.Dudley	DESIGNED -	REVISED -
	DRAWN -	REVISED -
PLOT SCALE = 100,0000' / in.	CHECKED -	REVISED -
PLOT DATE = 3/19/2024	DATE -	REVISED -

**STATE OF ILLINOIS**  
**DEPARTMENT OF TRANSPORTATION**

**TRAFFIC CONTROL PLAN**  
**I-55 SBPL CLOSURE**

SCALE: SHEET OF SHEETS STA. TO STA.

F.A.I. RTE.	SECTION	COUNTY	TOTAL SHEETS	SHEET NO.
55	(84-3HB-9)BDR	SANGAMON	18	13
ILLINOIS FED. AID PROJECT			CONTRACT NO. 72912	



SN 084-0007 (RR)

END TAPER  
STA 87+00

MATCH LINE STA 82+50

MATCH LINE STA 89+75

FAI 55 & 72 SB/WB

85+00

FAI 55 & 72 NB/EB

ADVANCED WARNING  
PER STD 701400

BEGIN TAPER  
STA 97+00

MATCH LINE STA 89+75

STA 94+00

FAI 55 & 72 SB/WB

90+00

FAI 55 & 72 NB/EB

95+00

**SYMBOLS**



WORK AREA



TYPE II BARRICADE, DRUM,  
OR VERTICAL BARRICADE



ARROW BOARD



DIRECTION INDICATOR BARRICADE WITH  
STEADY BURN MONODIRECTIONAL LIGHT



SIGN

TRAFFIC CONTROL NOTES:

1. TRAFFIC CONTROL DEVICES NOT SHOWN IN THIS DETAIL SHALL BE PER STANDARD 701400 & 701401.

MODEL: Default  
FILE NAME: S:\Addresses\Bridges\BDR\_CAD\72912 - 0840037 - Traffic\plan\sheet.dgn

USER NAME = Brandon.Dudley	DESIGNED -	REVISED -
DRAWN -	REVISOR -	REVISION -
PLOT SCALE = 100,0000' / in.	CHECKED -	REVISOR -
PLOT DATE = 3/19/2024	DATE -	REVISION -

**STATE OF ILLINOIS  
DEPARTMENT OF TRANSPORTATION**

**TRAFFIC CONTROL PLAN  
I-55 SBPL CLOSURE**

SCALE:	SHEET	OF	SHEETS	STA.	TO	STA.
--------	-------	----	--------	------	----	------

F.A.I. RTE.	SECTION	COUNTY	TOTAL SHEETS	SHEET NO.
55	(84-3HB-9)BDR	SANGAMON	18	14
ILLINOIS FED. AID PROJECT			CONTRACT NO. 72912	

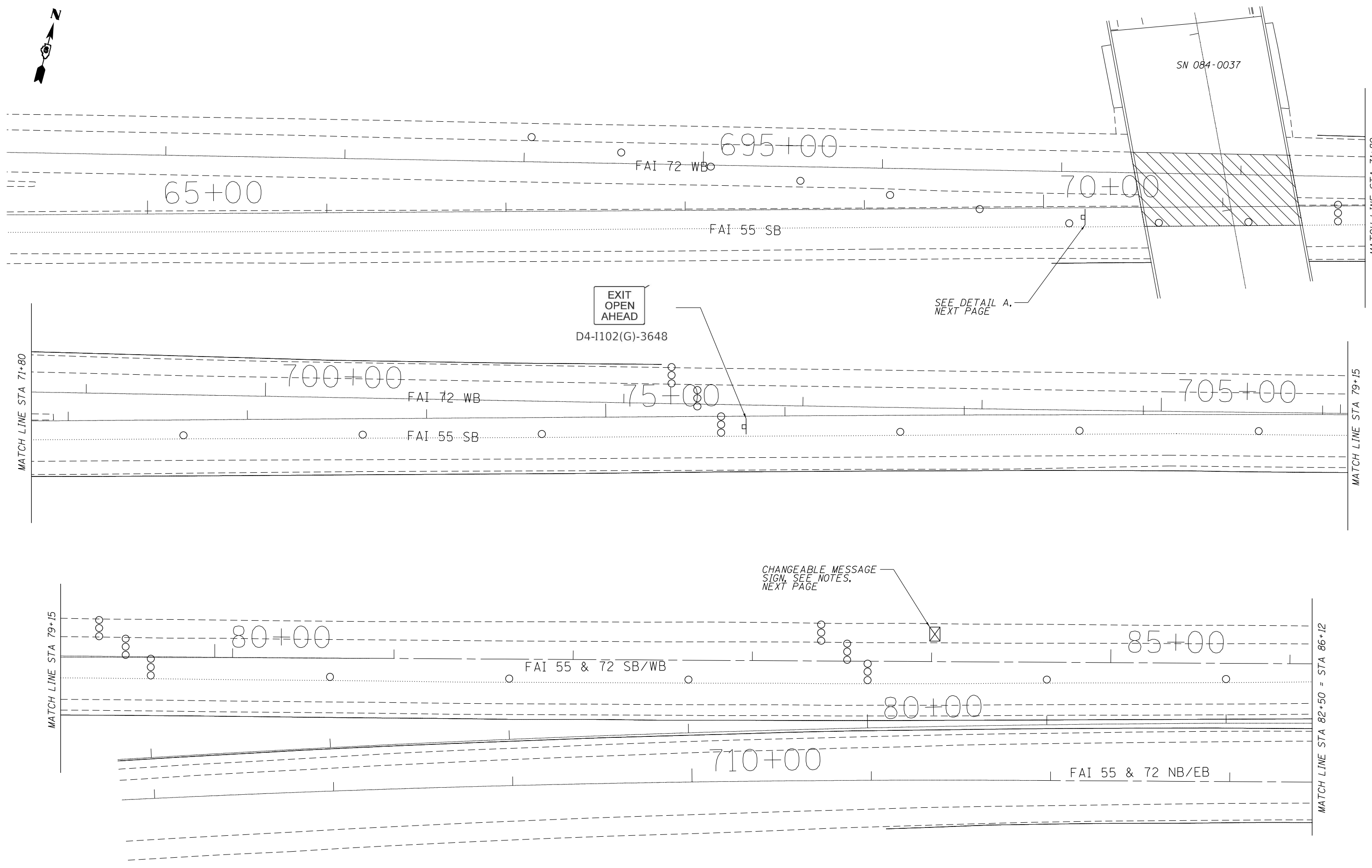

MODEL: Default  
 FILE NAME: S:\Addresses\Bridges\I-55\_CAD\72912 - 0840037\atching\abnrsheet.dgn

USER NAME = Brandon.Dudley	DESIGNED -	REVISED -
	DRAWN -	REVISED -
PLOT SCALE = 100,0000' / in.	CHECKED -	REVISED -
PLOT DATE = 3/19/2024	DATE -	REVISED -

**STATE OF ILLINOIS**  
**DEPARTMENT OF TRANSPORTATION**

<b>TRAFFIC CONTROL PLAN</b> <b>I-55 SBDL &amp; I-72 WB CLOSURE</b>			
SCALE:	SHEET	OF	SHEETS
	STA.	TO	STA.

F.A.I. RTE.	SECTION	COUNTY	TOTAL SHEETS	SHEET NO.
55	(84-3HB-9)BDR	SANGAMON	18	15
CONTRACT NO. 72912				
ILLINOIS FED. AID PROJECT				



SN 084-0007 (RR)

END TAPER  
STA 87+00

OVERHEAD  
SIGN

FAI 55 & 72 SB/WB

85+00

FAI 55 & 72 NB/EB

ADVANCED WARNING  
PER STD 701400

BEGIN TAPER  
STA 97+00

STA 94+00

FAI 55 & 72 SB/WB

90+00

FAI 55 & 72 NB/EB

95+00

**SYMBOLS**



WORK AREA



TYPE II BARRICADE, DRUM,  
OR VERTICAL BARRICADE



ARROW BOARD



DIRECTION INDICATOR BARRICADE WITH  
STEADY BURN MONODIRECTIONAL LIGHT



SIGN

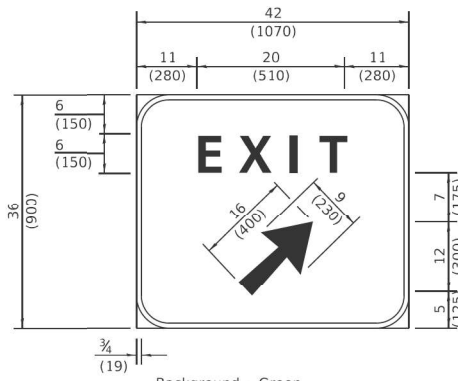

Background - Green  
Border and legend - White  
"D" size letters

EXIT SIGN - SPECIAL

**DETAIL A**

**TRAFFIC CONTROL NOTES:**

1. TRAFFIC CONTROL DEVICES NOT SHOWN IN THIS DETAIL SHALL BE PER STANDARD 701400 & 701401.
2. CMS AT STA 84+00 SHALL READ "I-72 EXIT OPEN 1/4 MILE AHEAD" AND SHALL BE PAID SEPARATELY FROM TC&P STANDARD 701401.

MODEL: D:\p\h\p\... FILE: NAME: S:\Addresses\Bridges\BDR\72912 - 0840037 - matching\plan\sheet.dgn

USER NAME = Brandon.Dudley	DESIGNED -	REVISED -
DRAWN -	REVISOR -	REVISION -
PLOT SCALE = 100,0000' / in.	CHECKED -	REVISOR -
PLOT DATE = 3/19/2024	DATE -	REVISION -

**STATE OF ILLINOIS  
DEPARTMENT OF TRANSPORTATION**

**TRAFFIC CONTROL PLAN  
I-55 SBDL & I-72 WB CLOSURE**

SCALE: SHEET OF SHEETS STA. TO STA.

F.A.I. RTE.	SECTION	COUNTY	TOTAL SHEETS	SHEET NO.
55	(84-3HB-9)BDR	SANGAMON	18	16
CONTRACT NO. 72912				
ILLINOIS FED. AID PROJECT				



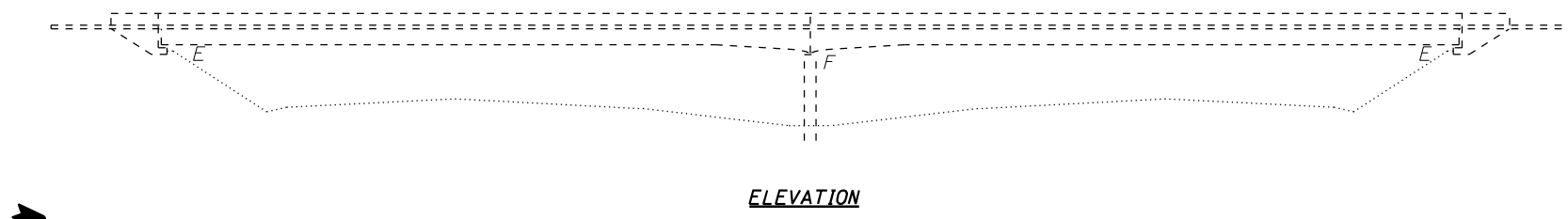

**ELEVATION**

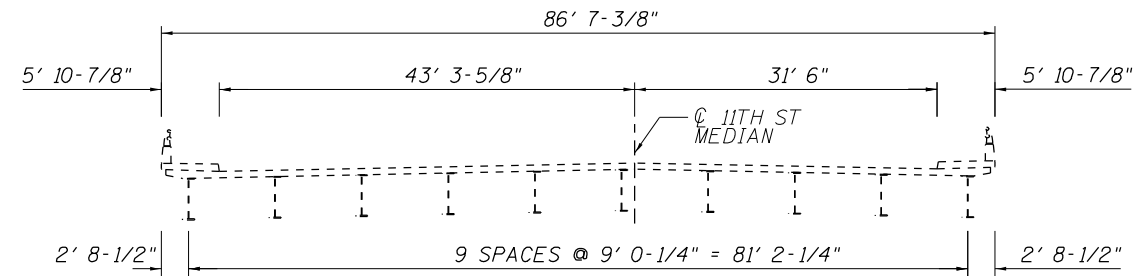

**CROSS SECTION**

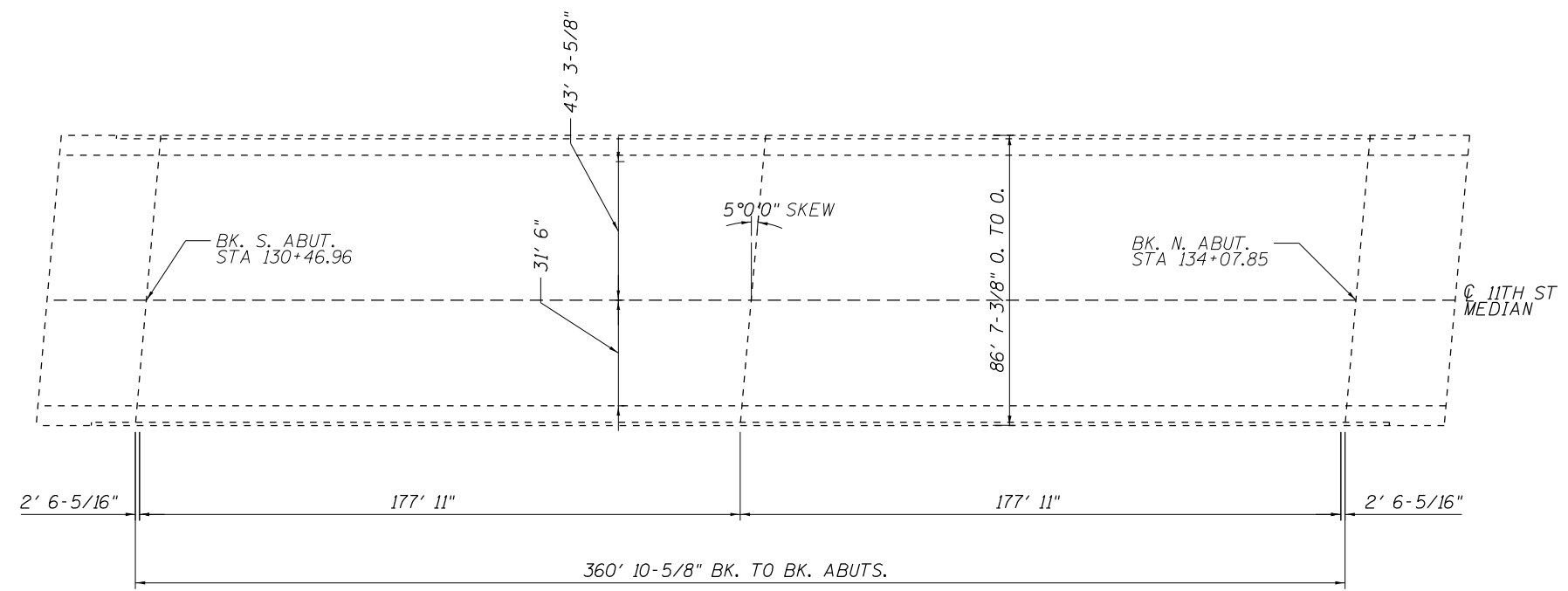

**PLAN**

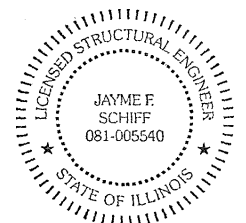

EXPIRES 11-30-2024

*Jayme F. Schiff*

**STRUCTURE GENERAL NOTES:**

PRIOR TO POURING THE NEW CONCRETE PATCHES, ALL HEAVY OR LOOSE MILL SCALE AND OTHER LOOSE OR POTENTIALLY DETRIMENTAL FOREIGN MATERIAL SHALL BE REMOVED FROM THE SURFACES IN CONTACT WITH CONCRETE. TIGHTLY ADHERED PAINT MAY REMAIN UNLESS OTHERWISE NOTED. REMOVAL SHALL BE ACCOMPLISHED BY METHODS THAT WILL NOT DAMAGE THE STEEL AND THE COST WILL BE INCLUDED IN CONCRETE REMOVAL.

PLAN DIMENSIONS AND DETAILS RELATIVE TO THE EXISTING STRUCTURE HAVE BEEN TAKEN FROM EXISTING PLANS ARE SUBJECT TO NOMINAL CONSTRUCTION VARIATIONS. THE CONTRACTOR SHALL FIELD VERIFY EXISTING DIMENSIONS AND DETAILS AFFECTING NEW CONSTRUCTION AND MAKE NECESSARY APPROVED ADJUSTMENTS PRIOR TO CONSTRUCTION OR ORDERING OF MATERIALS. SUCH VARIATIONS SHALL NOT BE CAUSE FOR ADDITIONAL COMPENSATION FOR A CHANGE IN THE SCOPE OF WORK, HOWEVER, THE CONTRACTOR WILL BE PAID FOR THE QUANTITY ACTUALLY FURNISHED AT THE UNIT PRICE BID FOR THE WORK.

EXISTING REINFORCEMENT BARS EXTENDING INTO THE REMOVAL AREA SHALL BE CLEANED, STRAIGHTENED, AND INCORPORATED INTO THE NEW CONSTRUCTION. ANY REINFORCEMENT BARS THAT ARE DAMAGED DURING CONCRETE REMOVAL SHALL BE REPLACED WITH AN APPROVED BAR SPLICER OR ANCHORAGE SYSTEM. COST INCLUDED WITH CONCRETE REMOVAL.

PROTECTIVE COAT SHALL BE APPLIED TO NEW CONCRETE ONLY.

**TOTAL BILL OF MATERIAL (SN 084-0037)**

ITEM	UNIT	QUANTITY
Deck Slab Repair (Partial)	Sq. Yd.	148
Approach Slab Repair (Partial Depth)	Sq. Yd.	10
Deck Slab Repair (Full Depth, Type II)	Sq. Yd.	18
Joint Sealing (Patches)	Foot	1800
Protective Coat	Sq. Yd.	176

MODEL: D:\p\h\... FILE NAME: S:\Addresses\Bridges\plan\_elev\084-0037\_patching\plan\_elev.dgn

USER NAME = Brandon.Dudley	DESIGNED - BRANDON DUDLEY	REVISED -
	DRAWN - BRANDON DUDLEY	REVISED -
PLOT SCALE = 100,0000' / in.	CHECKED -	REVISED -
PLOT DATE = 3/26/2024	DATE - 1/18/2024	REVISED -

**STATE OF ILLINOIS  
DEPARTMENT OF TRANSPORTATION**

**BRIDGE PLAN & ELEVATION  
SN 084-0037**

SCALE: SHEET 1 OF 2 SHEETS STA. TO STA.

F.A.I. RTE.	SECTION	COUNTY	TOTAL SHEETS	SHEET NO.
55	(84-3HB-9)BDR	SANGAMON	18	17
			CONTRACT NO. 72912	
ILLINOIS FED. AID PROJECT				

