

**ASHBURY DRIVE
EXISTING TYPICAL SECTION
STA. 9+000 TO STA. 9+80**

AREAS OF REMOVAL ITEMS VARIES
SEE PLAN SHEETS FOR DETAILED LOCATIONS.

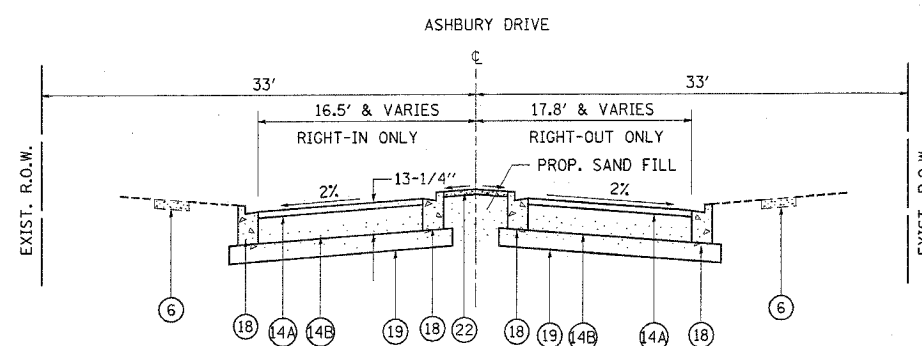

**ASHBURY DRIVE
PROPOSED TYPICAL SECTION
STA. 9+000 TO STA. 9+80
(RECONSTRUCTION)**

LEGEND

- ① EXISTING HMA SURFACING
- ② EXISTING HMA PAVEMENT, 9" (±)
- ③ EXISTING PC CONC. PAVEMENT, 9" & VARIES
- ④ EXISTING HMA BASE COURSE WIDENING, 9"
- ⑤ EXISTING COMB. CONC. CURB & GUTTER, TYPE B-6.12
- ⑥ EXISTING PC CONC. SIDEWALK, 4" OR 5"
- ⑦ EXISTING CORRUGATED PC CONCRETE MEDIAN (TO BE REMOVED)
- ⑧ EXISTING PC CONCRETE MEDIAN SURFACE, 4"
- ⑨ EXISTING HMA SHOULDER
- ⑩ EXISTING AGGREGATE SHOULDER (TO BE REMOVED AND PAID AS UNSUITABLE MATERIAL)
- ⑪ EXISTING SUB BASE GRANULAR MATERIAL, TYPE B
- ⑫ PROPOSED LEVELING BINDER (MM), N70, 1"
- ⑬ PROPOSED HMA PAVEMENT (FULL DEPTH), 9"
A. HMA SURFACE COURSE, MIX "D", N70, 2"
B. HMA BASE COURSE, 7"
- ⑭ PROPOSED HMA PAVEMENT (FULL DEPTH), 13-1/4"
A. HMA SURFACE COURSE, MIX "D", N70, 2"
B. HMA BASE COURSE, 11-1/4"
- ⑮ PROPOSED HMA SURFACE COURSE, MIX "D", N70, 1-1/2"
- ⑯ PROPOSED HMA SHOULDER, 8"
- ⑰ PROPOSED COMB. CONC. CURB & GUTTER, TYPEB-6.18
- ⑱ PROPOSED COMB. CONC. CURB & GUTTER, TYPE B-6-12
- ⑲ PROPOSED AGGREGATE SUBGRADE, 12"
- ⑳ PROPOSED AGGREGATE SHOULDER, TYPE B, 6"
- ㉑ PROPOSED TOPSOIL PLACEMENT, 6" & SODDING OR SEEDING
- ㉒ PROPOSED PC CONC. MEDIAN SURFACE, 4"
- ㉓ PROPOSED HMA BASE COURSE WIDENING, 10-3/4"
- ㉔ PROPOSED HMA BASE COURSE WIDENING, 6-1/2"

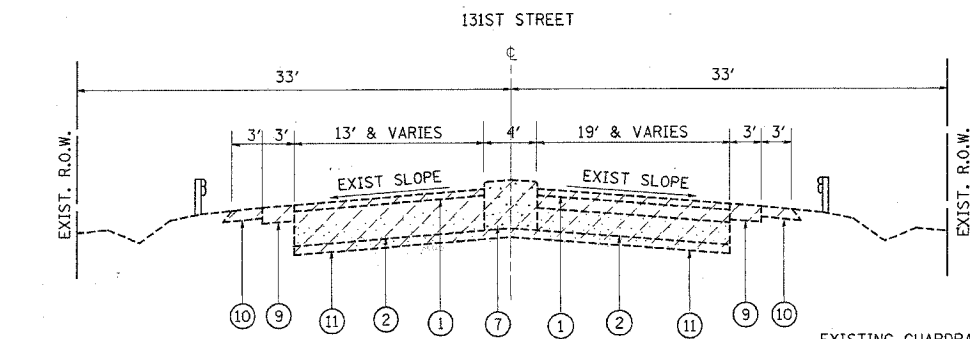

**131ST STREET
EXISTING TYPICAL SECTION
STA. 10+50 TO STA. 15+00**

AREAS OF REMOVAL ITEMS VARIES
SEE PLAN SHEETS FOR DETAILED LOCATIONS.

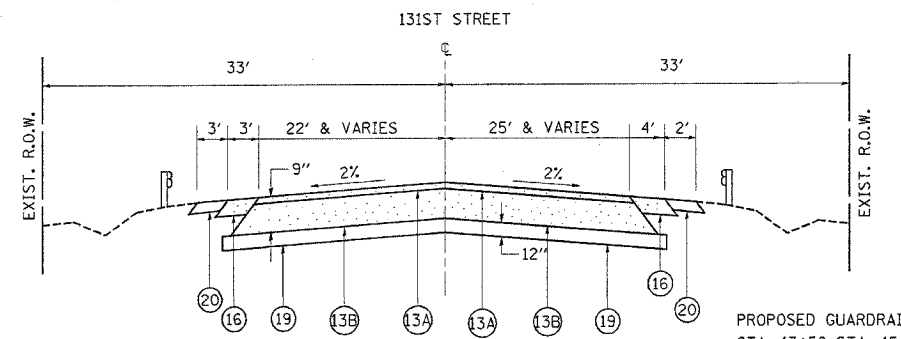

**131ST STREET
PROPOSED TYPICAL SECTION
STA. 10+00 TO STA. 11+40
(RECONSTRUCTION)**

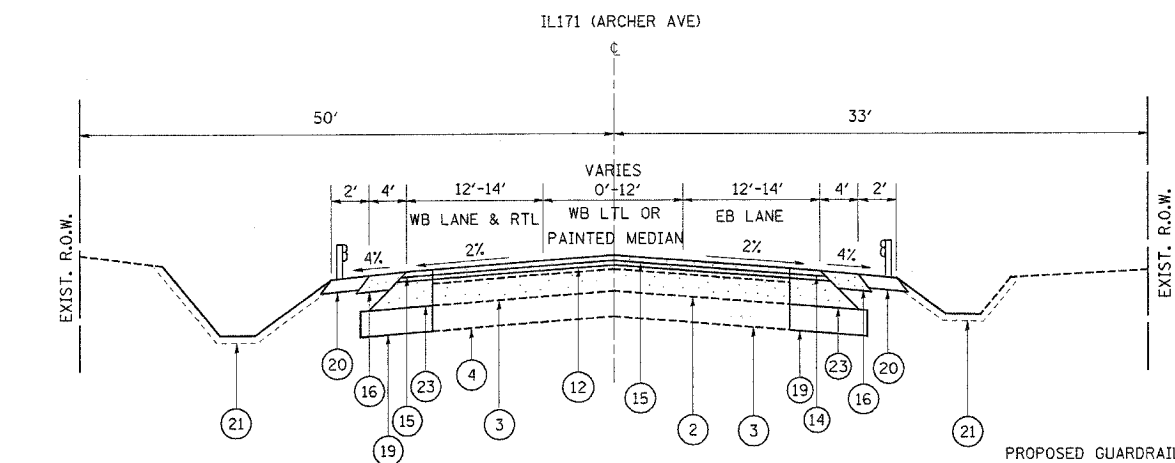

**ILL 171 (ARCHER AVE)
PROPOSED TYPICAL SECTION
STA. 21+31 TO STA. 26+80.0
(WIDENING/RESURFACING)**

NOTES:
FOR SUPERELEVATION AND PROFILE
CORRECTION USE LEVELING BINDER

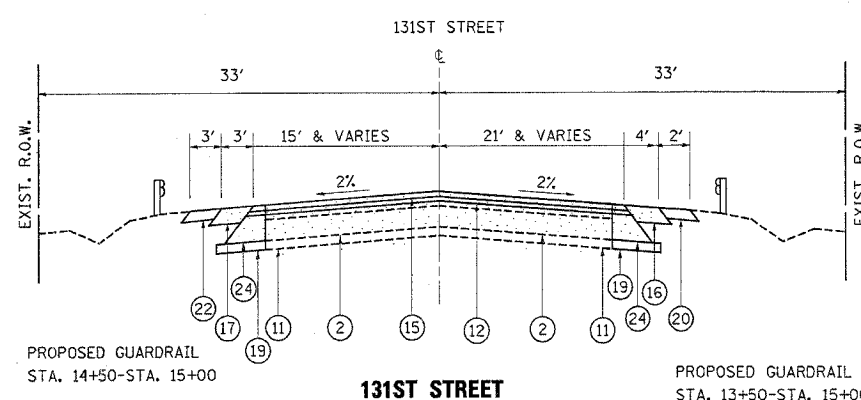

**131ST STREET
PROPOSED TYPICAL SECTION
STA. 11+40 TO STA. 15+00
(WIDENING RESURFACING)**

NOTES:

ADDITIONAL SUB-BASE GRANULAR MATERIAL UNDER PROPOSED CURB AND GUTTER SHALL NOT BE PAID FOR SEPARATELY BUT WILL BE CONSIDERED AS INCLUDED IN THE COST PER SQUARE YARD OF "SUB-BASE GRANULAR MATERIAL, TYPE B 4 INCHES.

ANY SAW CUTTING REQUIRED TO REMOVE ANY ITEM ADJACENT TO AN ITEM TO BE SAVED WILL BE CONSIDERED AS PART OF THE REMOVAL ITEM AND WILL NOT BE PAID FOR SEPARATELY.

THE HMA CONCRETE SURFACE REMOVAL SHALL BE PERFORMED AT THE PROPOSED CROSS-SLOPE SHOWN ON THE PROPOSED TYPICAL SECTIONS, AND NO ADDITIONAL COMPENSATION WILL BE PROVIDED FOR THIS REQUIREMENT.

MIXTURES FOR THE WIDENING AREA SHALL BE THE SAME MIXTURE USED IN THE RECONSTRUCTION AREA.

REVISIONS		ILLINOIS DEPARTMENT OF TRANSPORTATION ILL 171 (ARCHER AVE) AT ASHBURY DR & 131ST STREET
NAME	DATE	
		EXISTING AND PROPOSED TYPICAL SECTION
SCALE: VERT. _____		DRAWN BY _____
DATE _____		