

DISTRICT ONE-PLAN PREPARATION ENGINEER K. ENG / LONG TRAN (847) 705-4240

CONTRACT NO. 60A54

F.A.U. RTE.	SECTION	COUNTY	TOTAL SHEETS	SHEET NO.
1488	3212 RS-2	COOK	32	1
			+ 2	
			34	

STATE OF ILLINOIS  
DEPARTMENT OF TRANSPORTATION  
DIVISION OF HIGHWAYS

**PROPOSED  
HIGHWAY PLANS**  
F.A.U. 1488: 47TH STREET  
EAST/EBERLY AVE. TO IL43 (HARLEM AVENUE)  
SECTION: 3212 RS-2  
RESURFACING (MAINTENANCE)  
COOK COUNTY  
C-91-067-06

FOR INDEX OF SHEETS, SEE SHEET NO. 2

IMPROVEMENT IS LOCATED IN THE VILLAGES OF BROOKFIELD, LYONS, AND MCCOOK

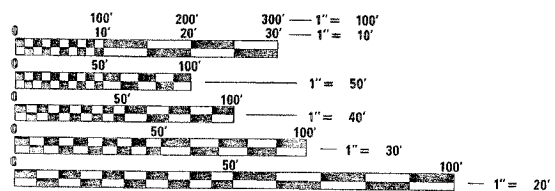
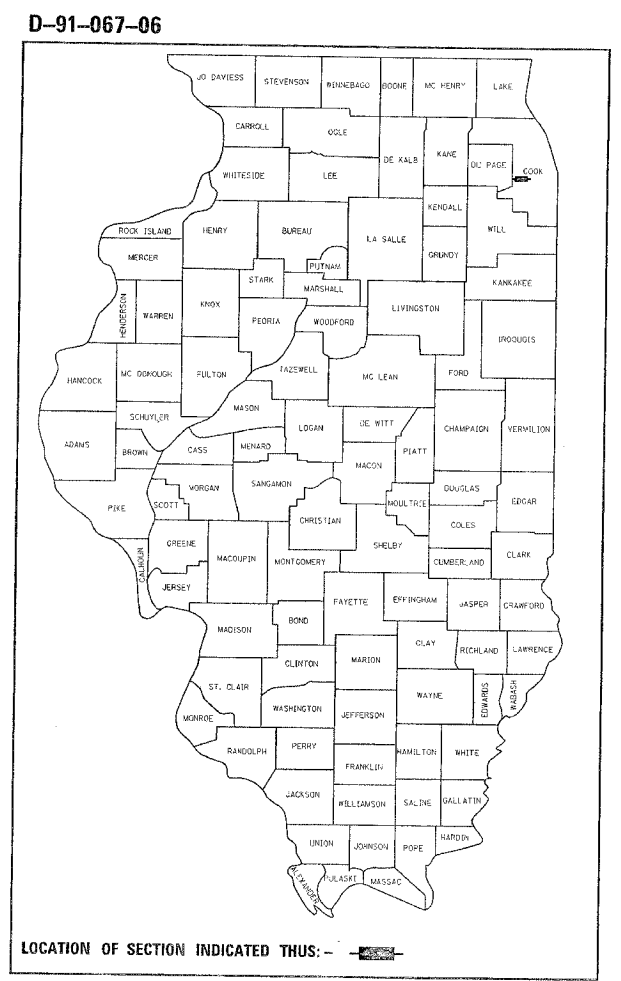

FULL SIZE PLANS HAVE BEEN PREPARED USING STANDARD ENGINEERING SCALES. REDUCED SIZED PLANS WILL NOT CONFORM TO STANDARD SCALES. IN MAKING MEASUREMENTS ON REDUCED PLANS, THE ABOVE SCALES MAY BE USED.

J.U.L.I.E.  
JOINT UTILITY LOCATION INFORMATION FOR EXCAVATION  
1-800-892-0123

CONTRACT NO. 60A54

OMISSIONS:  
STA. 168+17 TO STA. 174+59  
STA. 222+79 TO STA. 245+36

IMPROVEMENT BEGINS  
STA. 100+28

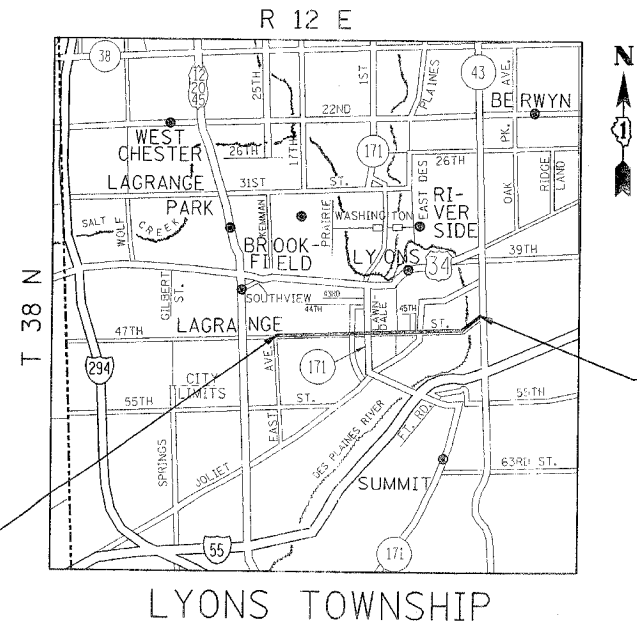

TRAFFIC DATA  
SPEED LIMIT: 40 MPH  
2006 ADT: 16,500

IMPROVEMENT ENDS  
STA. 258+07

GROSS LENGTH OF IMPROVEMENT = 15,779 FEET (2.99 MILES)  
NET LENGTH OF IMPROVEMENT = 12,880 FEET (2.44 MILES)

STATE OF ILLINOIS  
DEPARTMENT OF TRANSPORTATION  
DIVISION OF HIGHWAYS

SUBMITTED *March 22, 2007*

*Diane O'Keefe*  
DEPUTY DIRECTOR OF HIGHWAYS, REGION ENGINEER

*May 11, 2007*  
*Eric E. Hansen*  
ENGINEER OF DESIGN AND ENVIRONMENT

*May 11, 2007*  
*Victor R. Sees, P.E.*  
DIRECTOR OF HIGHWAY, CHIEF ENGINEER

PRINTED BY THE AUTHORITY  
OF THE STATE OF ILLINOIS



F.A.L. RTE.	SECTION	COUNTY	TOTAL SHEETS	SHEET NO.
1488	3212 RS-2	COOK	32	3
FED. ROAD DIST. NO. 1		ILLINOIS	HIGHWAY PROJECT	

SUMMARY OF QUANTITIES				CONSTRUCTION TYPE CODE					SUMMARY OF QUANTITIES				CONSTRUCTION TYPE CODE				
CODE NO	ITEM	UNIT	TOTAL QUANTITIES	URBAN I000					CODE NO	ITEM	UNIT	TOTAL QUANTITIES	URBAN I000				
				100% STATE									100% STATE				
40600200	BITUMINOUS MATERIALS (PRIME COAT)	TON	59	59					67100100	MOBILIZATION	L SUM	1	1				
40600300	AGGREGATE (PRIME COAT)	TON	291	291					70100310	TRAFFIC CONTROL AND PROTECTION, STANDARD 701421	L SUM	1	1				
40600400	MIXTURE FOR CRACKS, JOINTS, AND FLANGEWAYS	TON	44	44					70102625	TRAFFIC CONTROL AND PROTECTION, STANDARD 701606	L SUM	1	1				
40600895	CONSTRUCTING TEST STRIP	EACH	2	2					70102630	TRAFFIC CONTROL AND PROTECTION, STANDARD 701601	L SUM	1	1				
40600982	HOT-MIX ASPHALT SURFACE REMOVAL - BUTT JOINT	SQ YD	590	590					70102635	TRAFFIC CONTROL AND PROTECTION, STANDARD 701701	L SUM	1	1				
40601005	HOT-MIX ASPHALT REPLACEMENT OVER PATCHES	TON	523	523					70300100	SHORT-TERM PAVEMENT MARKING	FOOT	10212	10212				
40603340	HOT-MIX ASPHALT SURFACE COURSE, MIX "D", N70	TON	6295	6295					70300210	TEMPORARY PAVEMENT MARKING - LETTERS AND SYMBOLS	SQ FT	575	575				
42001300	PROTECTIVE COAT	SQ YD	156	156					70300220	TEMPORARY PAVEMENT MARKING - LINE 4"	FOOT	37439	37439				
44000158	HOT-MIX ASPHALT SURFACE REMOVAL, 2 1/4"	SQ YD	72762	72762					70300240	TEMPORARY PAVEMENT MARKING - LINE 6"	FOOT	3771	3771				
44001700	COMBINATION CONCRETE CURB AND GUTTER REMOVAL AND REPLACEMENT	FOOT	700	700					70300260	TEMPORARY PAVEMENT MARKING - LINE 12"	FOOT	859	859				
44002225	HOT-MIX ASPHALT REMOVAL OVER PATCHES, 6 1/4"	SQ YD	1495	1495					70300270	TEMPORARY PAVEMENT MARKING - LINE 16"	FOOT	162	162				
44201753	CLASS D PATCHES, TYPE II, 9 INCH	SQ YD	720	720					70300280	TEMPORARY PAVEMENT MARKING - LINE 24"	FOOT	600	600				
44201757	CLASS D PATCHES, TYPE III, 9 INCH	SQ YD	500	500					70301000	WORK ZONE PAVEMENT MARKING REMOVAL	SQ FT	1135	1135				
44201759	CLASS D PATCHES, TYPE IV, 9 INCH	SQ YD	275	275					* 78000100	THERMOPLASTIC PAVEMENT MARKING - LETTERS AND SYMBOLS	SQ FT	575	575				
55039700	STORM SEWERS TO BE CLEANED	FOOT	400	400					* 78000200	THERMOPLASTIC PAVEMENT MARKING - LINE 4"	FOOT	37439	37439				
60250200	CATCH BASINS TO BE ADJUSTED	EACH	3	3					* 78000400	THERMOPLASTIC PAVEMENT MARKING - LINE 6"	FOOT	3771	3771				
60250800	CATCH BASINS TO BE ADJUSTED WITH NEW TYPE 5 FRAME, OPEN LID	EACH	3	3					* 78000600	THERMOPLASTIC PAVEMENT MARKING - LINE 12"	FOOT	859	859				
60250900	CATCH BASINS TO BE ADJUSTED WITH NEW TYPE 5 FRAME, CLOSED LID	EACH	3	3					* 78000610	THERMOPLASTIC PAVEMENT MARKING - LINE 16"	FOOT	162	162				
60252800	CATCH BASINS TO BE RECONSTRUCTED	EACH	8	8					* 78000650	THERMOPLASTIC PAVEMENT MARKING - LINE 24"	FOOT	600	600				
60260100	INLETS TO BE ADJUSTED	EACH	8	8					* 78100100	RAISED REFLECTIVE PAVEMENT MARKER	EACH	1328	1328				
60261530	INLETS TO BE ADJUSTED WITH NEW TYPE 23 FRAME AND GRATE	EACH	4	4					78300200	RAISED REFLECTIVE PAVEMENT MARKER REMOVAL	EACH	1132	1132				
60264130	INLETS TO BE RECONSTRUCTED WITH NEW TYPE 23 FRAME AND GRATE	EACH	7	7					* 88600600	DETECTOR LOOP REPLACEMENT	FOOT	776	776				
60300310	FRAMES AND LIDS TO BE ADJUSTED (SPECIAL)	EACH	90	90					X0322256	TEMPORARY INFORMATION SIGNING	SQ FT	51.4	51.4				
60406200	FRAMES AND LIDS, TYPE 5, OPEN LID	EACH	13	13													
67000400	ENGINEER'S FIELD OFFICE, TYPE A	CAL MO	6	6													

\* SPECIALTY ITEMS

REVISIONS	
NAME	DATE

ILLINOIS DEPARTMENT OF TRANSPORTATION  
SUMMARY OF QUANTITIES  
47TH STREET

3/21/2007

F.A.U. RTE.	SECTION	COUNTY	TOTAL SHEETS	SHEET NO.
1488	3212 RS-2	COOK	32	4
FED. ROAD DIST. NO. 1		ILLINOIS	HIGHWAY PROJECT	

SUMMARY OF QUANTITIES			TOTAL QUANTITIES	CONSTRUCTION TYPE CODE				
CODE NO	ITEM	UNIT		URBAN 1000				
X4067107	POLYMERIZED LEVELING BINDER (MACHINE METHOD), IL-4.75, N50	TON	3148	3148				
Z0018500	DRAINAGE STRUCTURES TO BE CLEANED	EACH	40	40				
Z0048665	RAILROAD PROTECTIVE LIABILITY INSURANCE	L SUM	1	1				

SUMMARY OF QUANTITIES			TOTAL QUANTITIES	CONSTRUCTION TYPE CODE				
CODE NO	ITEM	UNIT						

3/20/2007 2:58:02 PM C:\PROJECTS\60A54\60A54.DWG

REVISIONS	
NAME	DATE

ILLINOIS DEPARTMENT OF TRANSPORTATION  
SUMMARY OF QUANTITIES  
47TH STREET

F.A. RTE.	SECTION	COUNTY	TOTAL SHEETS	SHEET NO.
1488	3212 RS-2	COOK	32	5
STA.		TO STA.		
FED. ROAD DIST. NO. 1		ILLINOIS	FED. AID PROJECT	

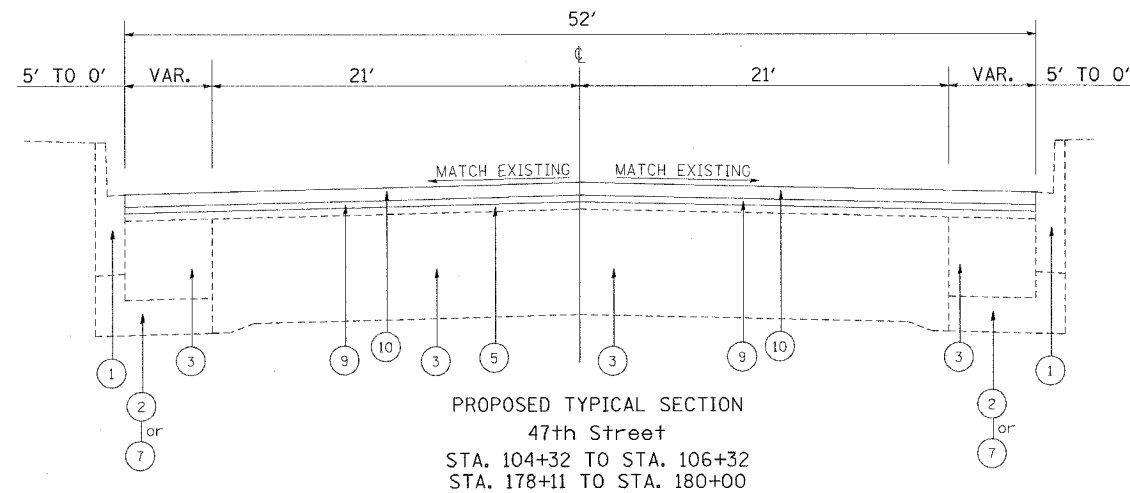
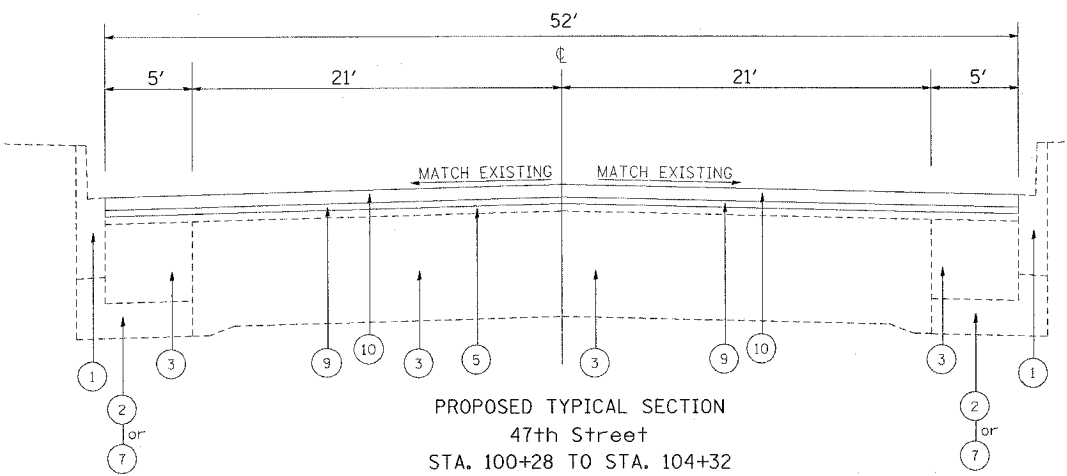
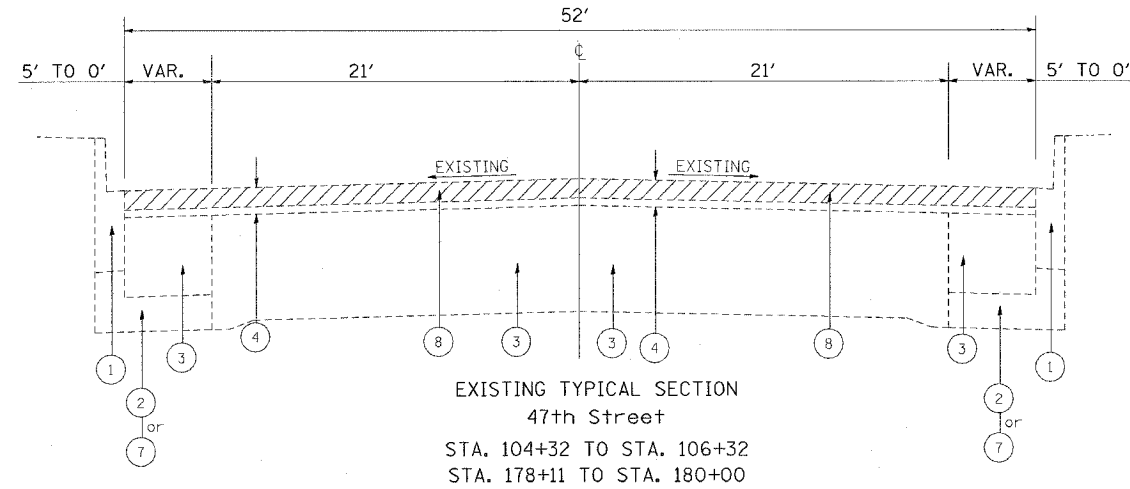
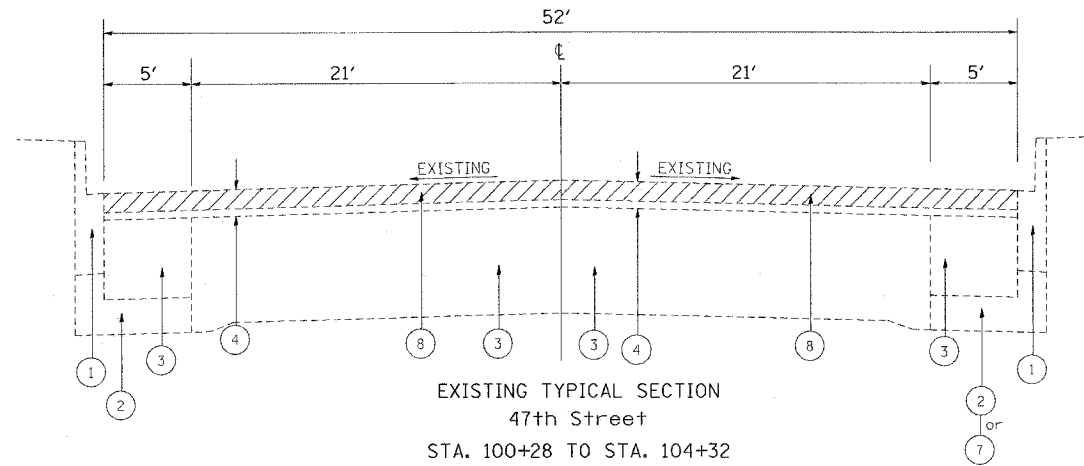

HOT-MIX ASPHALT MIXTURE REQUIREMENTS

MIXTURE USES	POLYMERIZED LEVELING BINDER (MACHINE METHOD), IL-4.75, N50	HOT-MIX ASPHALT SURFACE, MIX "D", N70 (IL-9.5 MM)	HOT-MIX ASPHALT REPLACEMENT OVER PATCHES (BINDER IL-19MM)	CLASS D PATCHES (BINDER IL-19MM)	PARTIAL DEPTH PATCHING (2") (BINDER IL-19MM)
AC/PG	SBS/SBR PG 76-28/22	PG 64-22	PG 64-22/58-22	PG 64-22/58-22	PG 64-22/58-22
DESIGN AIR VOIDS	4.0% @ 50 GYR	4.0% @ 70 GYR	4% @ 70 GYR	4% @ 70 GYR	4% @ 70 GYR

— THE UNIT WEIGHT USED TO CALCULATE ALL HOT-MIX ASPHALT SURFACE MIX QUANTITIES IS 112 LBS/SY/IN  
 — WHEN RAP EXCEEDS 20%, THE NEW ASPHALT BINDER SHALL BE PG 58/22

LEGEND

- ① EXISTING COMBINATION CONCRETE CURB AND GUTTER, TYPE B6.12 (MODIFIED)
- ② EXISTING SUB-BASE GRANULAR MATERIAL, TYPE B (4")
- ③ EXISTING PC CONC. BASE COURSE VARIES 7 1/2" TO 9 1/2" ±
- ④ EXISTING HOT-MIX ASPHALT OVERLAY VARIES 4 1/2" TO 10" ±
- ⑤ EXISTING HOT-MIX ASPHALT OVERLAY AFTER MILLING
- ⑥ EXISTING P.C. CONCRETE BARRIER MEDIAN
- ⑦ EXISTING SUB-BASE GRAN MATERIAL, TYPE B (6")
- ⑧ PROPOSED HOT-MIX ASPHALT SURFACE REMOVAL, 2 1/4"
- ⑨ PROPOSED POLYMERIZED LEVELING BINDER (MACHINE METHOD), IL-4.75, N50, 3/4"
- ⑩ PROPOSED HOT-MIX ASPHALT SURFACE COURSE, MIX "D", N70, 1 1/2"

REVISIONS	
NAME	DATE

ILLINOIS DEPARTMENT OF TRANSPORTATION  
 47TH STREET  
 EXISTING AND PROPOSED  
 TYPICAL CROSS SECTIONS  
 SCALE: N.T.S.  
 DATE \_\_\_\_\_ DRAWN BY \_\_\_\_\_  
 CHECKED BY \_\_\_\_\_

PLOT DATE = 3/28/2007  
 FILE NAME = c:\projects\105705\design\adgn  
 PLOT SCALE = 2500.0000 / IN.  
 USER NAME = abreuh

F.A. RTE.	SECTION	COUNTY	TOTAL SHEETS	SHEET NO.
1488	3212 RS-2	COOK	32	6
STA.		TO STA.		
FED. ROAD DIST. NO. 1		ILLINOIS	FED. AID PROJECT	

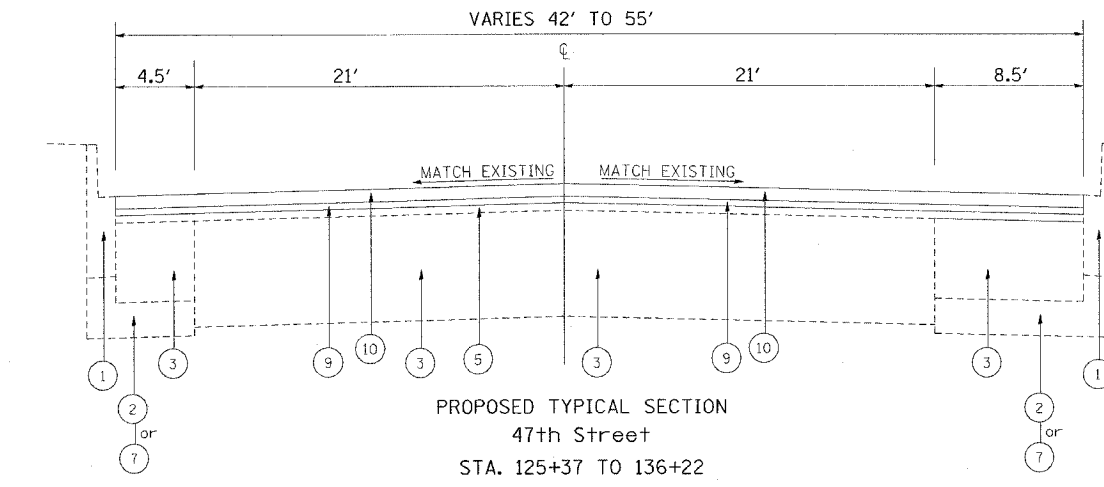
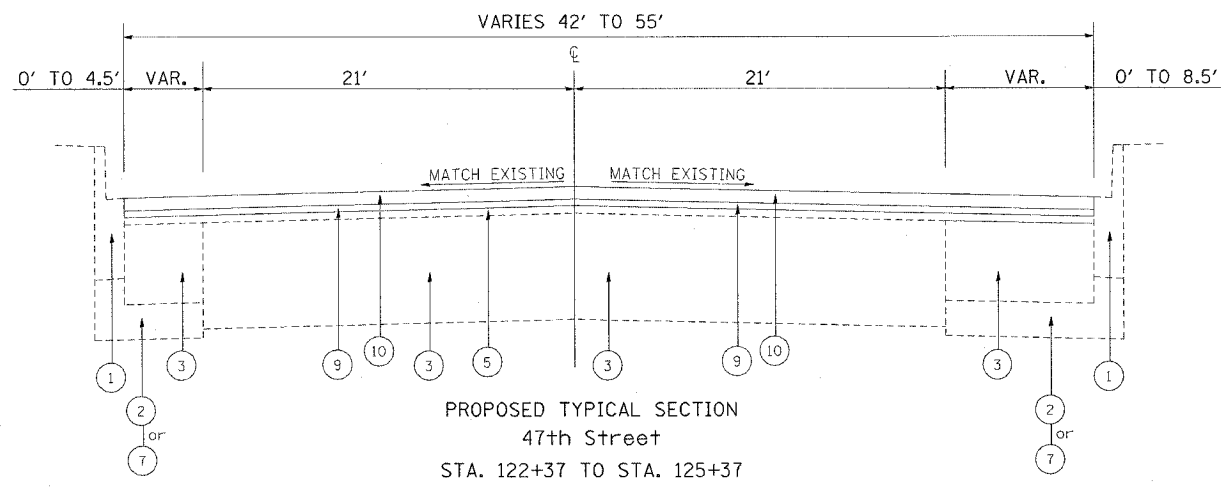
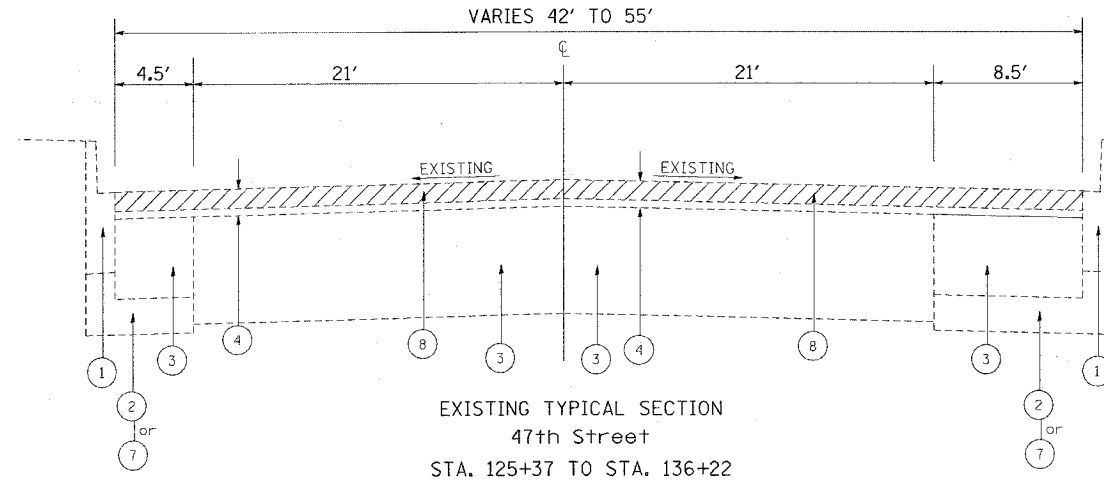
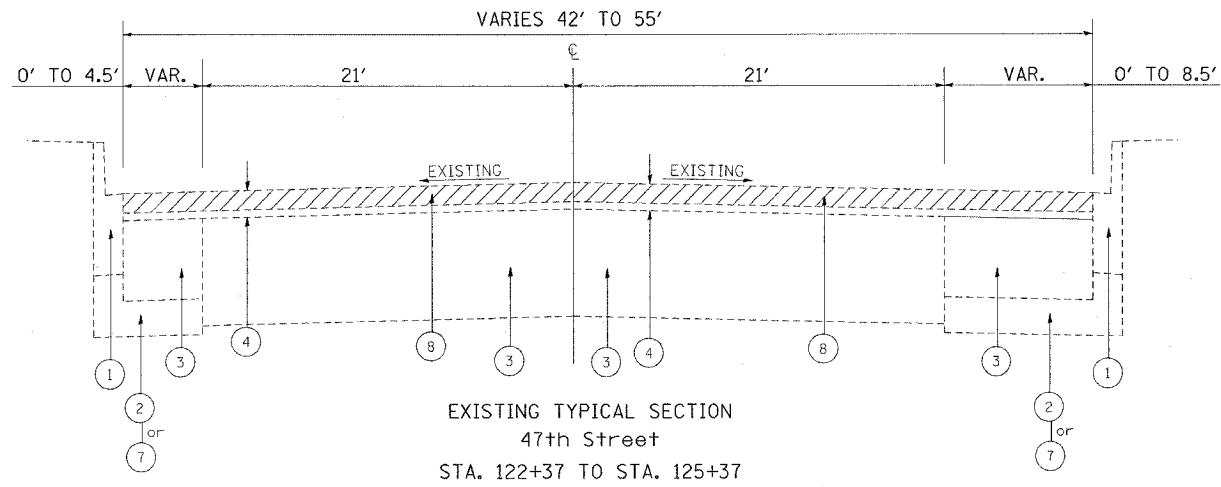

LEGEND

- 1 EXISTING COMBINATION CONCRETE CURB AND GUTTER, TYPE B6.12 (MODIFIED)
- 2 EXISTING SUB-BASE GRANULAR MATERIAL, TYPE B (4")
- 3 EXISTING PC CONC. BASE COURSE VARIES 7 1/2" TO 9 1/2" ±
- 4 EXISTING HOT-MIX ASPHALT OVERLAY VARIES 4 1/2" TO 10" ±
- 5 EXISTING HOT-MIX ASPHALT OVERLAY AFTER MILLING
- 6 EXISTING P.C. CONCRETE BARRIER MEDIAN

- 7 EXISTING SUB-BASE GRAN MATERIAL, TYPE B (6")
- 8 PROPOSED HOT-MIX ASPHALT SURFACE REMOVAL, 2 1/4"
- 9 PROPOSED POLYMERIZED LEVELING BINDER (MACHINE METHOD), IL-4.75, N50, 3/4"
- 10 PROPOSED HOT-MIX ASPHALT SURFACE COURSE, MIX "D", N70, 1 1/2"

PLOT DATE = 3/26/2007  
 FILE NAME = c:\projects\1106796\design\as.dgn  
 PLOT SCALE = 2500/8000 = 1/4" = 1'-0"  
 USER NAME = gbruce

REVISIONS	
NAME	DATE

ILLINOIS DEPARTMENT OF TRANSPORTATION  
 47TH STREET  
 EXISTING AND PROPOSED  
 TYPICAL CROSS SECTIONS  
 SCALE: N.T.S.  
 DATE \_\_\_\_\_ DRAWN BY \_\_\_\_\_  
 CHECKED BY \_\_\_\_\_

F.A. RTE.	SECTION	COUNTY	TOTAL SHEETS	SHEET NO.
148B	3212 RS-2	COOK	32	7
STA.		TO STA.		
FED. ROAD DIST. NO. 1		ILLINOIS FED. AID PROJECT		

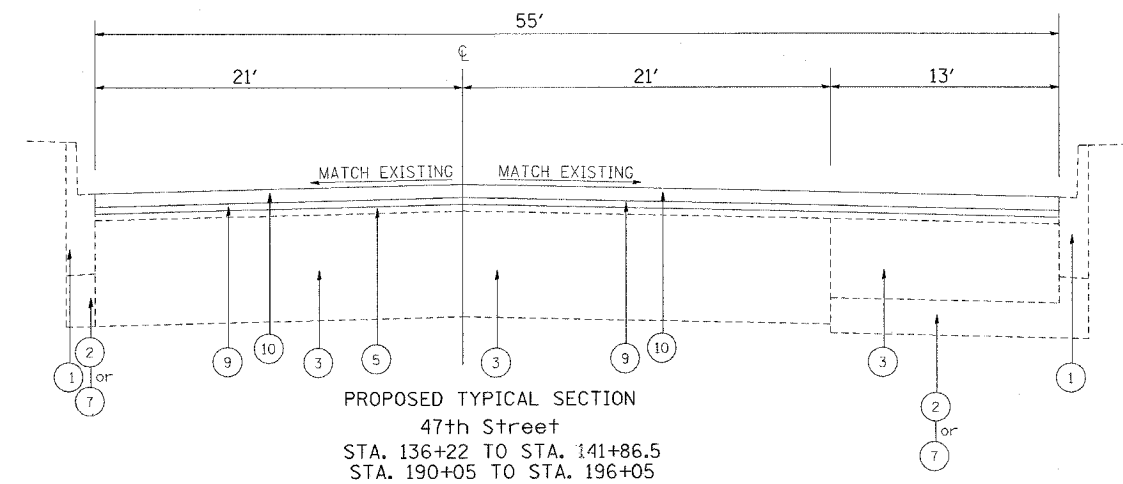
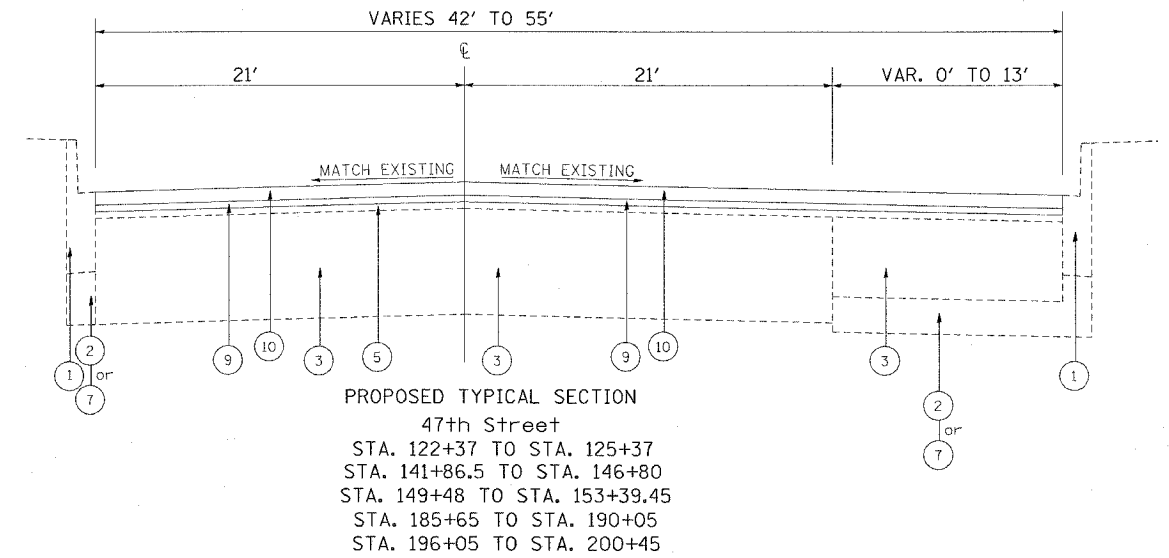
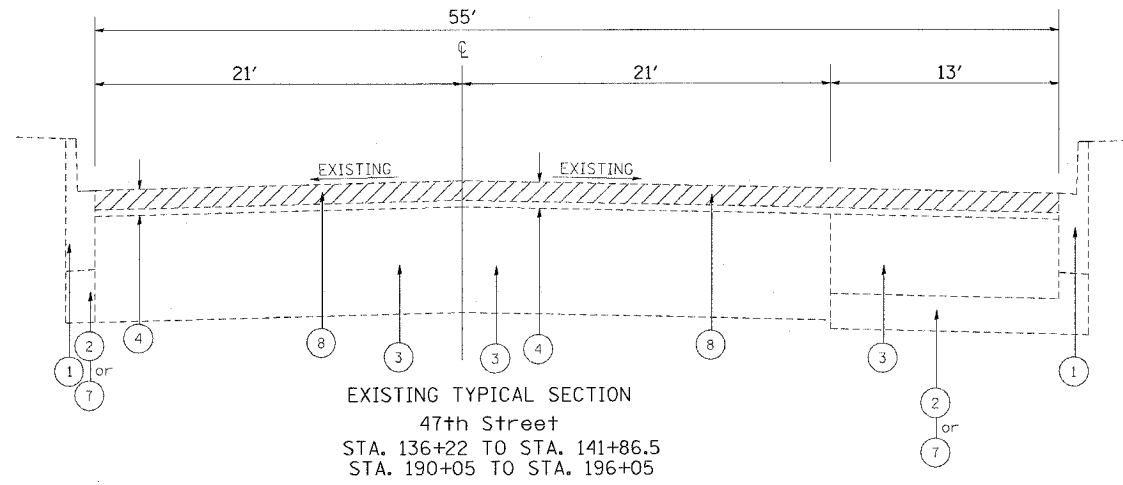
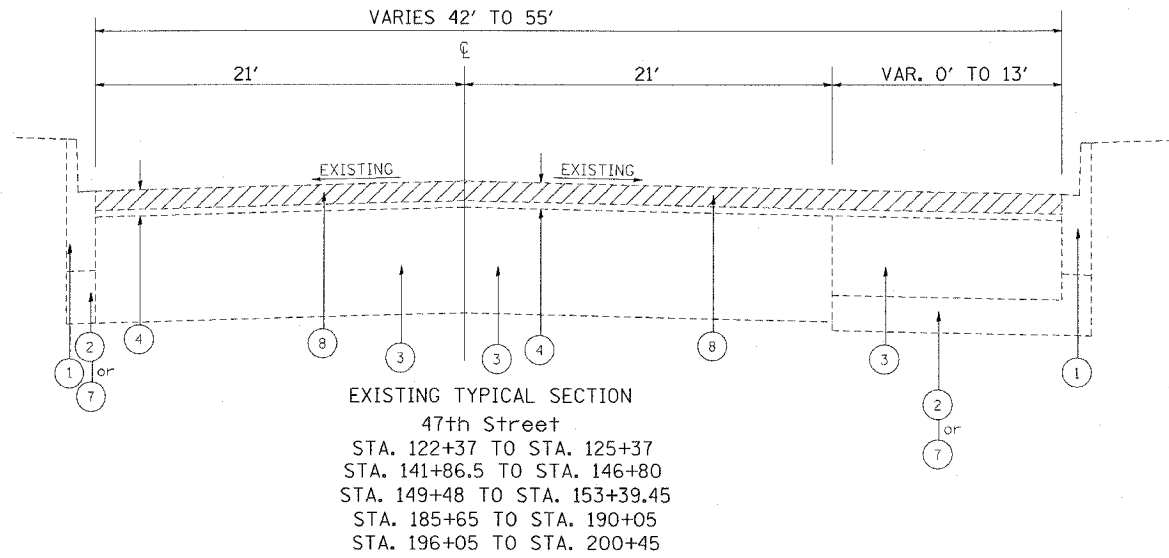

**LEGEND**

- ① EXISTING COMBINATION CONCRETE CURB AND GUTTER, TYPE B6.12 (MODIFIED)
- ② EXISTING SUB-BASE GRANULAR MATERIAL, TYPE B (4")
- ③ EXISTING PC CONC. BASE COURSE VARIES 7 1/2" TO 9 1/2" ±
- ④ EXISTING HOT-MIX ASPHALT OVERLAY VARIES 4 1/2" TO 10" ±
- ⑤ EXISTING HOT-MIX ASPHALT OVERLAY AFTER MILLING
- ⑥ EXISTING P.C. CONCRETE BARRIER MEDIAN

- ⑦ EXISTING SUB-BASE GRAN MATERIAL, TYPE B (6")
- ⑧ PROPOSED HOT-MIX ASPHALT SURFACE REMOVAL, 2 1/4"
- ⑨ PROPOSED POLYMERIZED LEVELING BINDER (MACHINE METHOD), IL-4.75, N50, 3/4"
- ⑩ PROPOSED HOT-MIX ASPHALT SURFACE COURSE, MIX "D", N70, 1 1/2"

REVISIONS	
NAME	DATE

ILLINOIS DEPARTMENT OF TRANSPORTATION  
47TH STREET  
EXISTING AND PROPOSED  
TYPICAL CROSS SECTIONS

SCALE: N.T.S. DRAWN BY  
DATE CHECKED BY

PLOT DATE = 3/20/2007  
FILE NAME = c:\projects\148B\148B.dwg  
PLOT SCALE = 2500:0000  
USER NAME = abraham

F.A. RTE.	SECTION	COUNTY	TOTAL SHEETS	SHEET NO.
1488	3212 RS-2	COOK	32	8
STA.		TO STA.		
FED. ROAD DIST. NO. 1		ILLINOIS FED. AID PROJECT		

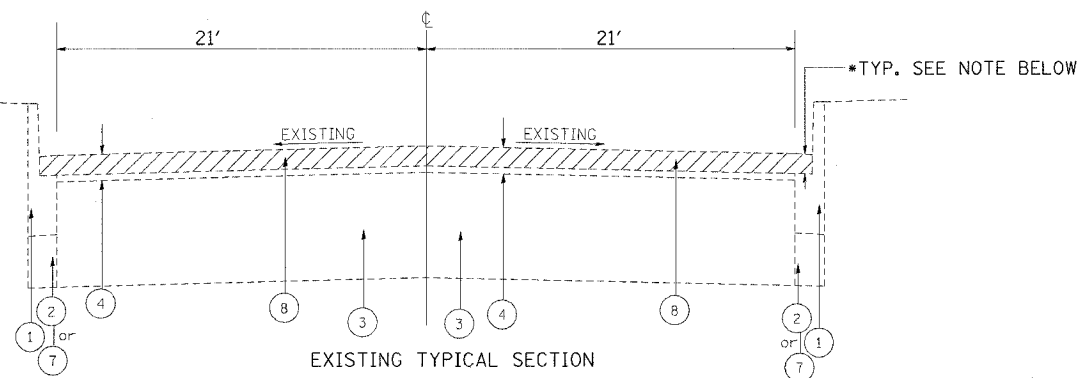

EXISTING TYPICAL SECTION  
47th Street  
STA. 106+32 TO STA. 122+37  
STA. 146+80 TO STA. 149+48  
STA. 180+00 TO STA. 185+65  
STA. 200+45 TO STA. 222+78.6  
STA. 245+36.2 TO STA. 258+07

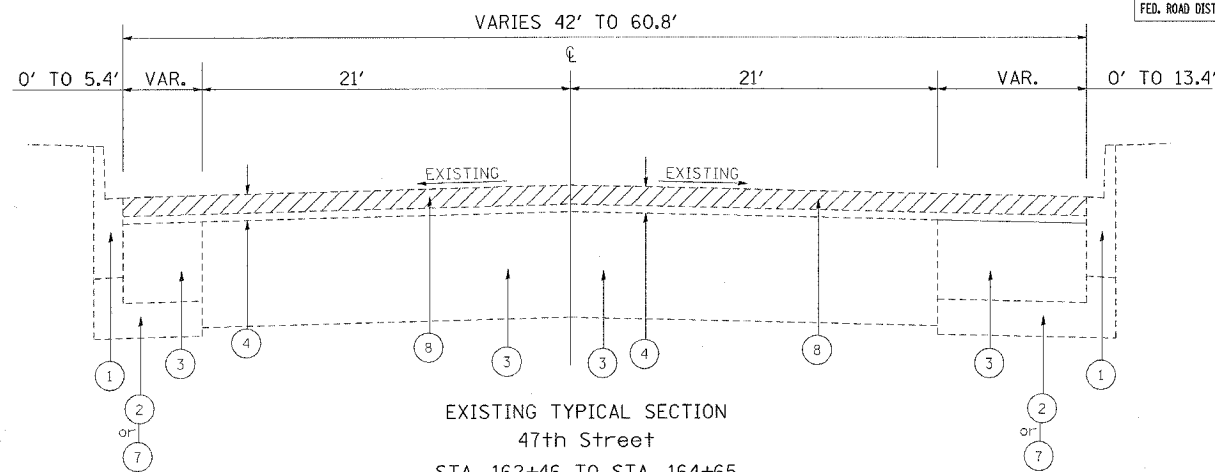

EXISTING TYPICAL SECTION  
47th Street  
STA. 162+46 TO STA. 164+65

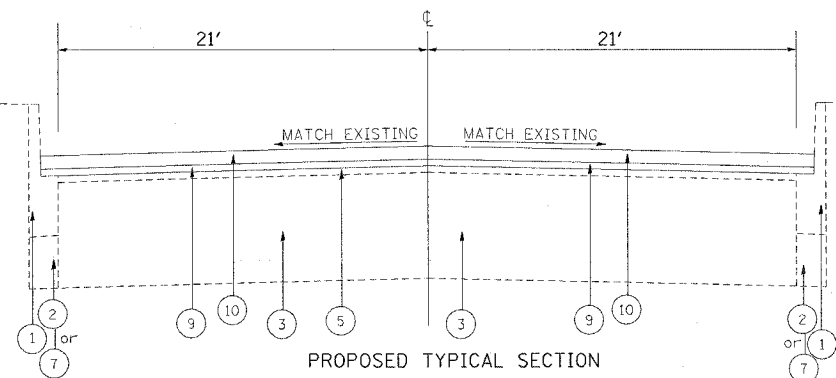

PROPOSED TYPICAL SECTION  
47th Street  
STA. 106+32 TO STA. 122+37  
STA. 146+80 TO STA. 149+48  
STA. 180+00 TO STA. 185+65  
STA. 200+45 TO STA. 222+78.6  
STA. 245+36.2 TO STA. 258+07

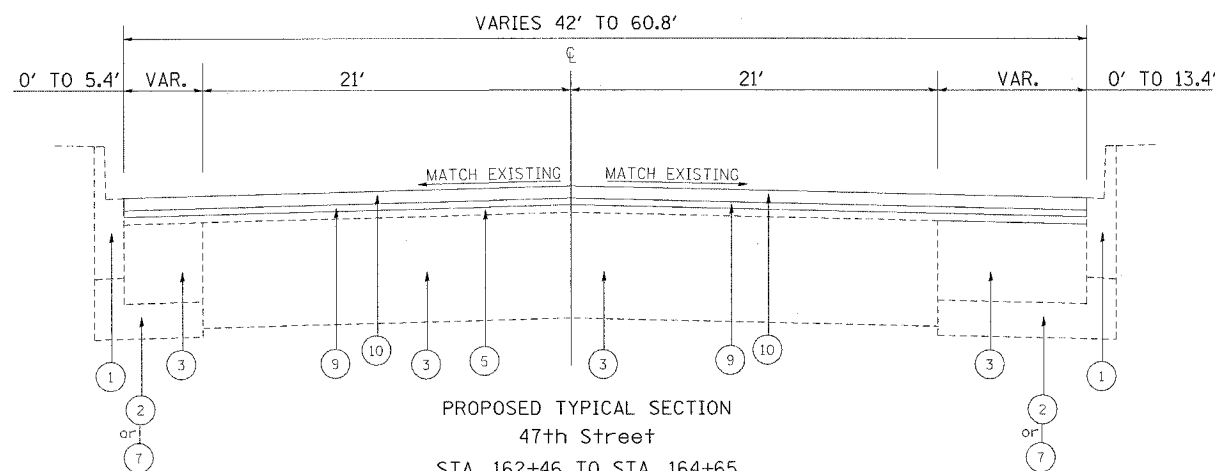

PROPOSED TYPICAL SECTION  
47th Street  
STA. 162+46 TO STA. 164+65

LEGEND

- ① EXISTING COMBINATION CONCRETE CURB AND GUTTER, TYPE B6.12 (MODIFIED)
- ② EXISTING SUB-BASE GRANULAR MATERIAL, TYPE B (4")
- ③ EXISTING PC CONC. BASE COURSE VARIES 7 1/2" TO 9 1/2" ±
- ④ EXISTING HOT-MIX ASPHALT OVERLAY VARIES 4 1/2" TO 10" ±
- ⑤ EXISTING HOT-MIX ASPHALT OVERLAY AFTER MILLING
- ⑥ EXISTING P.C. CONCRETE BARRIER MEDIAN

- ⑦ EXISTING SUB-BASE GRAN MATERIAL, TYPE B (6")
- ⑧ PROPOSED HOT-MIX ASPHALT SURFACE REMOVAL, 2 1/4"
- ⑨ PROPOSED POLYMERIZED LEVELING BINDER (MACHINE METHOD), IL-4.75, N50, 3/4"
- ⑩ PROPOSED HOT-MIX ASPHALT SURFACE COURSE, MIX "D", N70, 1 1/2"

\*GUTTER FLAG HAS BEEN OVERLAYED AT VARIOUS LOCATIONS THROUGHOUT JOB LIMITS. REMOVAL OF THE HOT-MIX ASPHALT OVERLAY ON THE GUTTER SHALL BE PAID FOR UNDER "HOT-MIX ASPHALT SURFACE REMOVAL 2 1/4". LOCATIONS TO BE DETERMINED BY ENGINEER.

REVISIONS	
NAME	DATE

ILLINOIS DEPARTMENT OF TRANSPORTATION  
47TH STREET  
EXISTING AND PROPOSED  
TYPICAL CROSS SECTIONS

SCALE: N.T.S.  
DATE

DRAWN BY  
CHECKED BY



F.A. RTE.	SECTION	COUNTY	TOTAL SHEETS	SHEET NO.
1488	3212 RS-2	COOK	32	9
STA.		TO STA.		
FED. ROAD DIST. NO. 1		ILLINOIS FED. AID PROJECT		

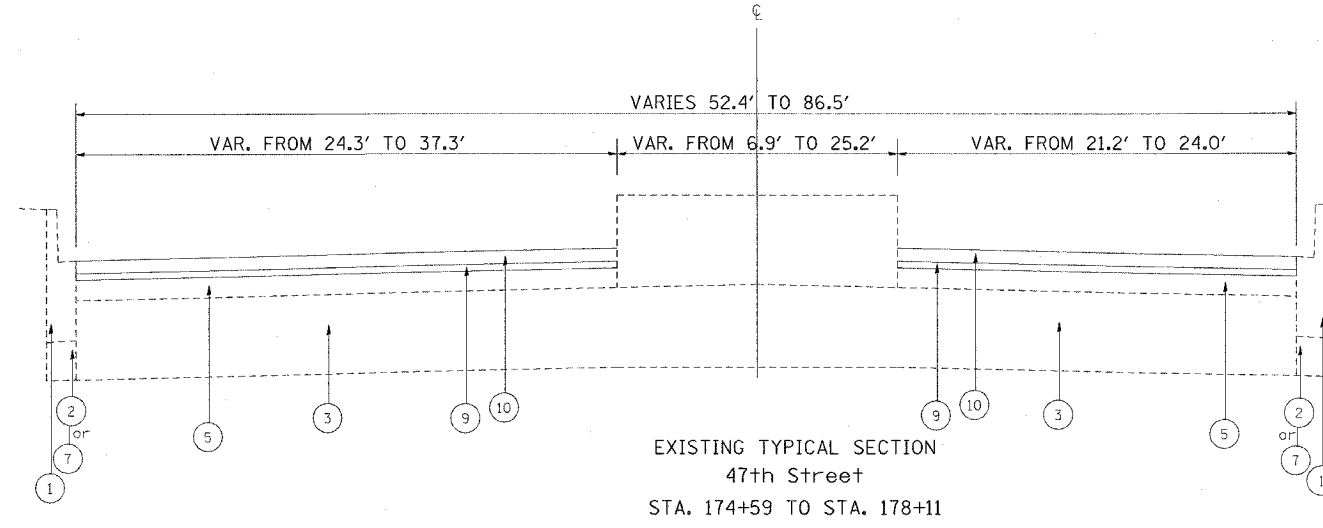
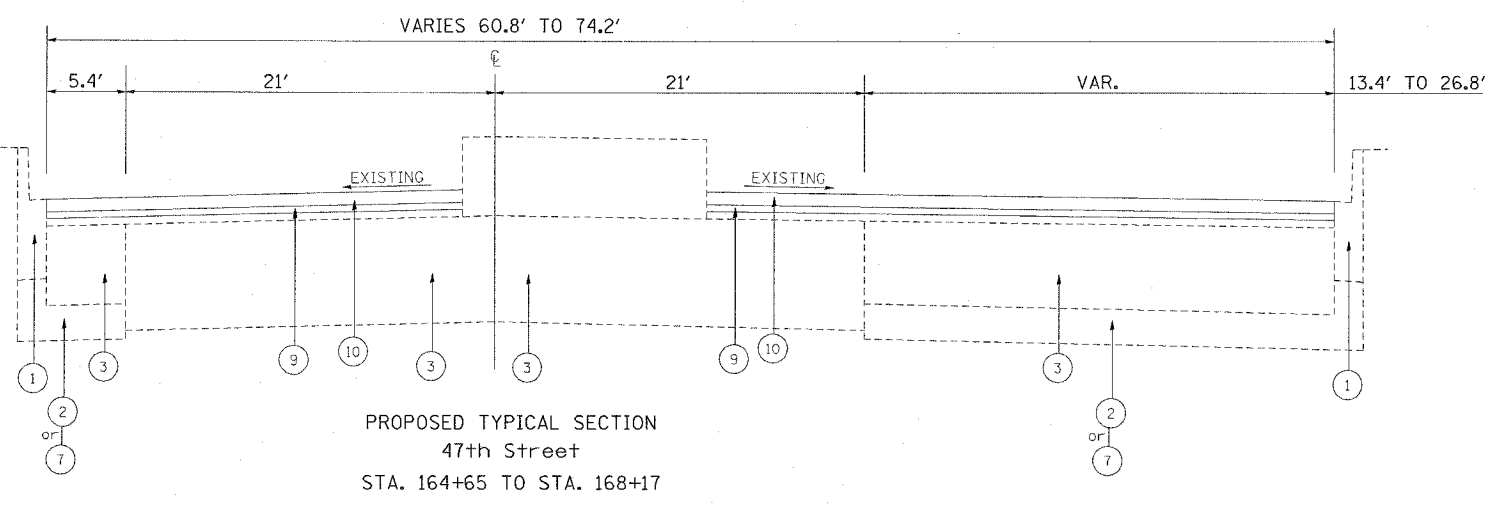
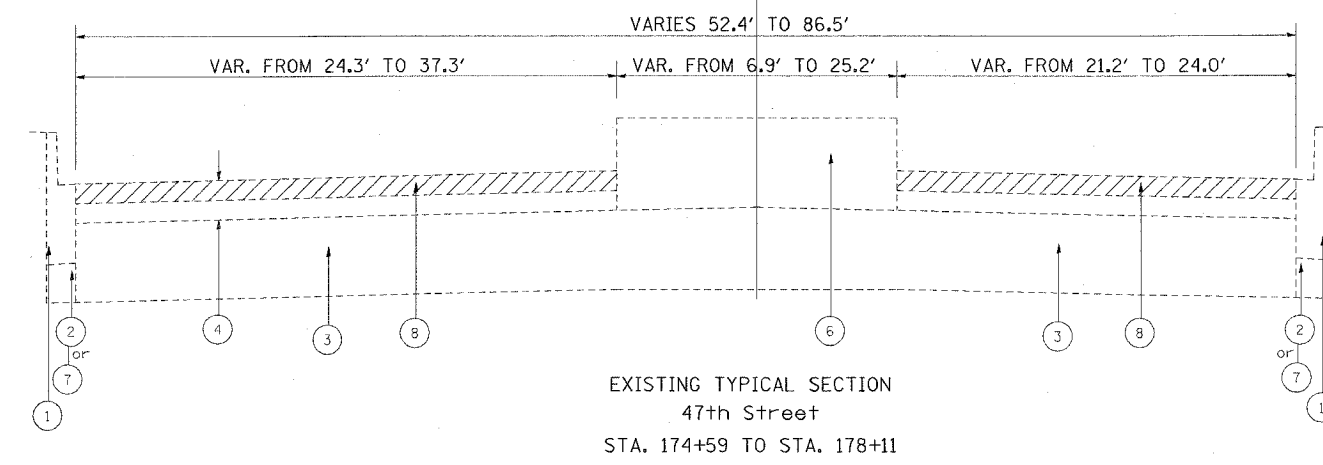
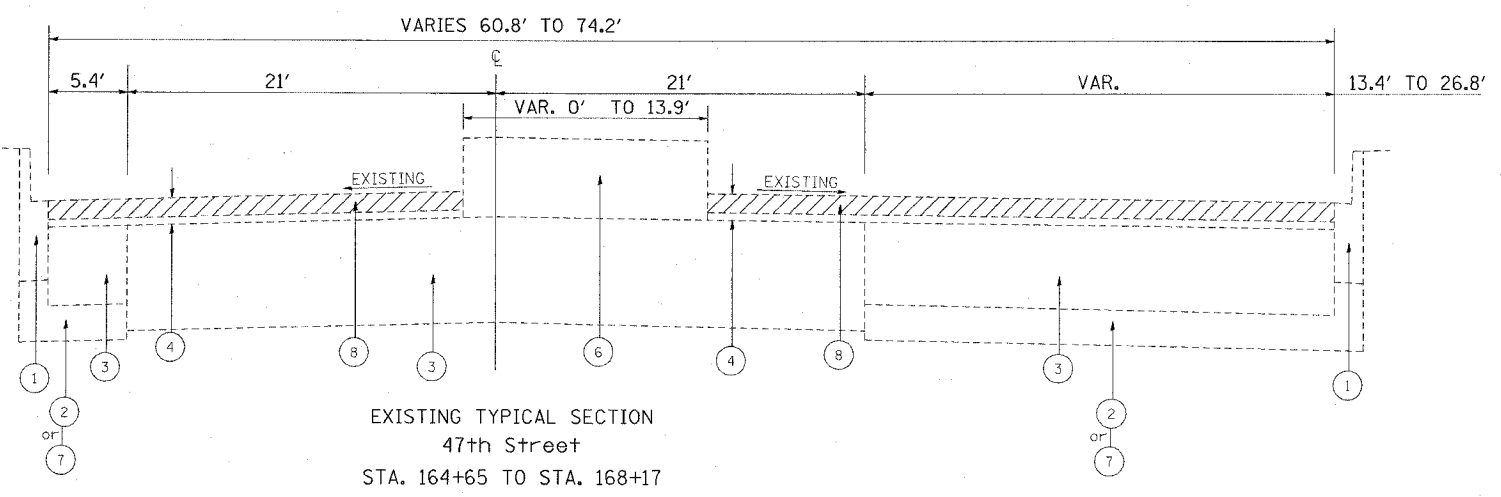

**LEGEND**

- ① EXISTING COMBINATION CONCRETE CURB AND GUTTER, TYPE B6.12 (MODIFIED)
- ② EXISTING SUB-BASE GRANULAR MATERIAL, TYPE B (4")
- ③ EXISTING PC CONC. BASE COURSE VARIES 7 1/2" TO 9 1/2" ±
- ④ EXISTING HOT-MIX ASPHALT OVERLAY VARIES 4 1/2" TO 10" ±
- ⑤ EXISTING HOT-MIX ASPHALT OVERLAY AFTER MILLING
- ⑥ EXISTING P.C. CONCRETE BARRIER MEDIAN
- ⑦ EXISTING SUB-BASE GRAN MATERIAL, TYPE B (6")
- ⑧ PROPOSED HOT-MIX ASPHALT SURFACE REMOVAL, 2 1/4"
- ⑨ PROPOSED POLYMERIZED LEVELING BINDER (MACHINE METHOD), IL-4.75, N50, 3/4"
- ⑩ PROPOSED HOT-MIX ASPHALT SURFACE COURSE, MIX "D", N70, 1 1/2"

REVISIONS		ILLINOIS DEPARTMENT OF TRANSPORTATION
NAME	DATE	
		47TH STREET EXISTING AND PROPOSED TYPICAL CROSS SECTIONS
SCALE: N.T.S.		DRAWN BY
DATE		CHECKED BY

PLOT DATE = 3/20/2007  
 PLOT SCALE = 2500.0000 / IN.  
 USER NAME = abreuah

F.A.U. RTE.	SECTION	COUNTY	TOTAL SHEETS	SHEET NO.
1488	3212 RS-2	COOK	32	10
STA.		TO STA.		
FED. ROAD DIST. NO. 1		ILLINOIS	HIGHWAY PROJECT	

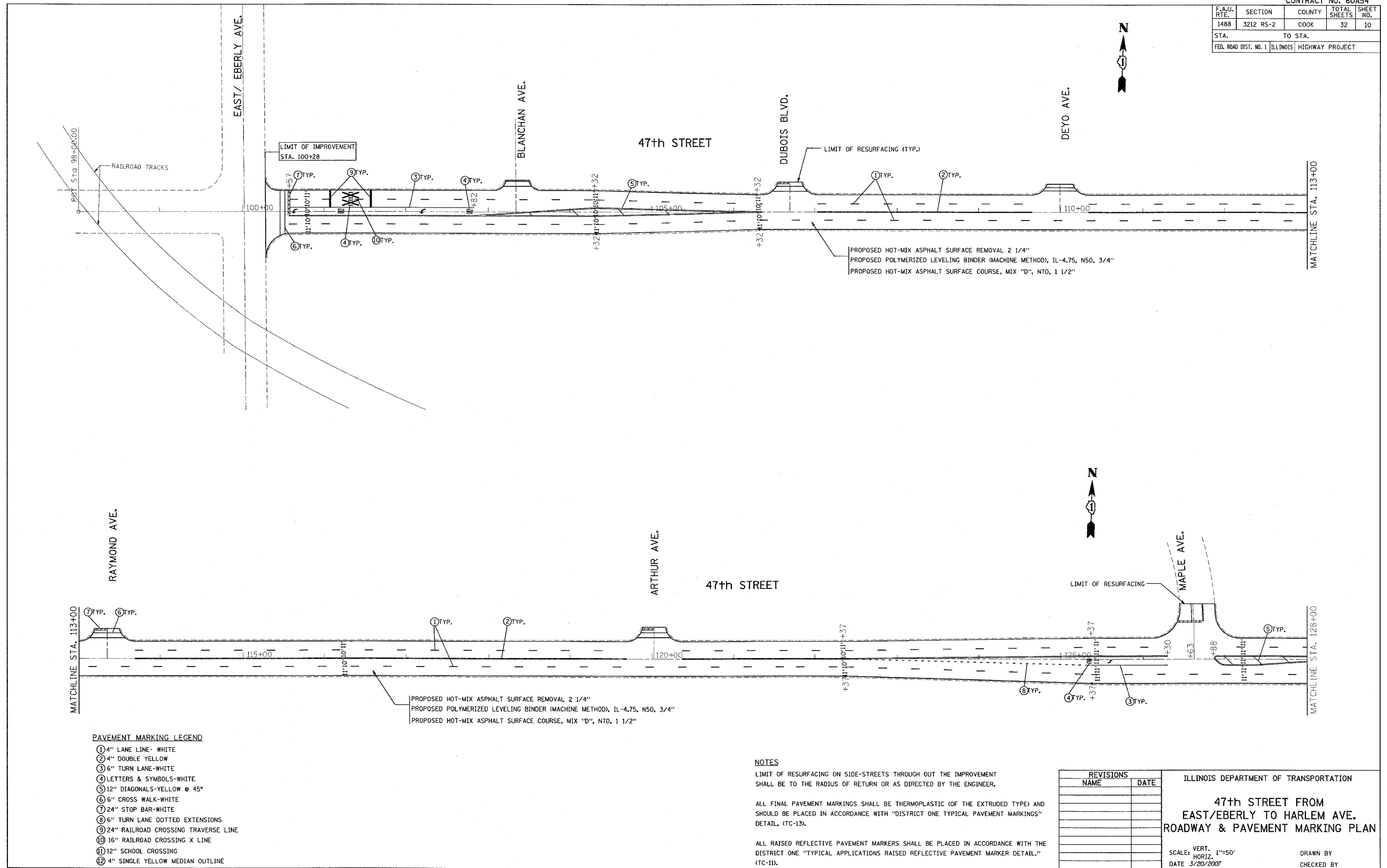

**PAVEMENT MARKING LEGEND**

- ① 4" LANE LINE-WHITE
- ② 4" DOUBLE YELLOW
- ③ 6" TURN LANE-WHITE
- ④ LETTERS & SYMBOLS-WHITE
- ⑤ 12" DIAGONALS-YELLOW @ 45°
- ⑥ 6" CROSS WALK-WHITE
- ⑦ 24" STOP BAR-WHITE
- ⑧ 6" TURN LANE DOTTED EXTENSIONS
- ⑨ 24" RAILROAD CROSSING TRAVERSE LINE
- ⑩ 16" RAILROAD CROSSING X LINE
- ⑪ 12" SCHOOL CROSSING
- ⑫ 4" SINGLE YELLOW MEDIAN OUTLINE

PROPOSED HOT-MIX ASPHALT SURFACE REMOVAL 2 1/4"  
 PROPOSED POLYMERIZED LEVELING BINDER (MACHINE METHOD), IL-4.75, N50, 3/4"  
 PROPOSED HOT-MIX ASPHALT SURFACE COURSE, MIX "D", N70, 1 1/2"

**NOTES**

LIMIT OF RESURFACING ON SIDE-STREETS THROUGH OUT THE IMPROVEMENT SHALL BE TO THE RADIUS OF RETURN OR AS DIRECTED BY THE ENGINEER.

ALL FINAL PAVEMENT MARKINGS SHALL BE THERMOPLASTIC (OF THE EXTRUDED TYPE) AND SHOULD BE PLACED IN ACCORDANCE WITH "DISTRICT ONE TYPICAL PAVEMENT MARKINGS" DETAIL, (TC-13).

ALL RAISED REFLECTIVE PAVEMENT MARKERS SHALL BE PLACED IN ACCORDANCE WITH THE DISTRICT ONE "TYPICAL APPLICATIONS RAISED REFLECTIVE PAVEMENT MARKER DETAIL" (TC-11).

REVISIONS	
NAME	DATE

ILLINOIS DEPARTMENT OF TRANSPORTATION

**47th STREET FROM EAST/EBERLY TO HARLEM AVE. ROADWAY & PAVEMENT MARKING PLAN**

SCALE: VERT. 1"=50'  
 HORIZ. 1"=50'

DATE 3/20/2007

DRAWN BY  
 CHECKED BY

PLOT DATE = 3/20/2007  
 FILE NAME = C:\Users\jld06796\design\design  
 PLOT SCALE = 50.0000 / IN.  
 USER NAME = abreaub

F.A.U. RTE.	SECTION	COUNTY	TOTAL SHEETS	SHEET NO.
1488	3212 RS-2	COOK	32	11
STA.		TO STA.		
FED. ROAD DIST. NO. 1		ILLINOIS HIGHWAY PROJECT		

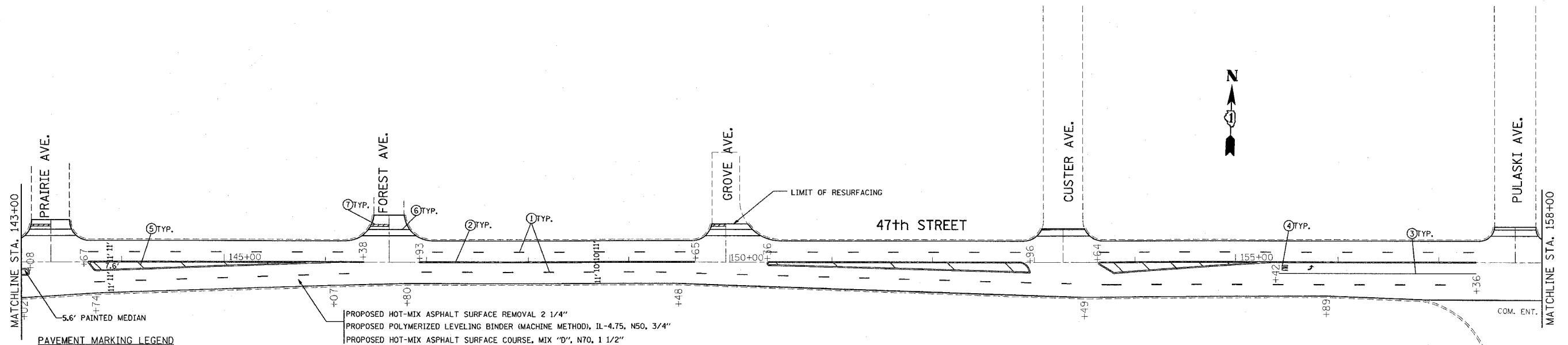
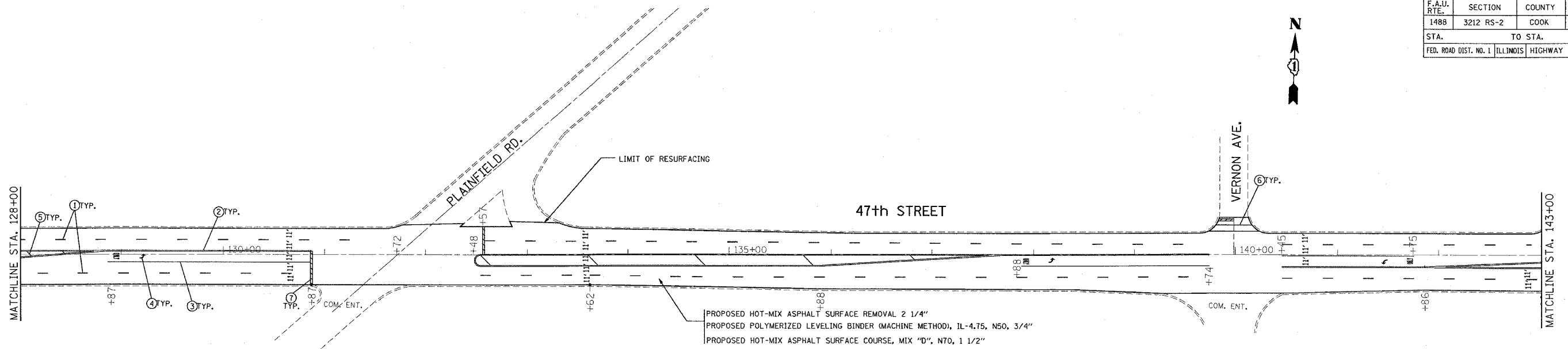

**PAVEMENT MARKING LEGEND**

- ① 4" LANE LINE- WHITE
- ② 4" DOUBLE YELLOW
- ③ 6" TURN LANE- WHITE
- ④ LETTERS & SYMBOLS- WHITE
- ⑤ 12" DIAGONALS- YELLOW @ 45°
- ⑥ 6" CROSS WALK- WHITE
- ⑦ 24" STOP BAR- WHITE
- ⑧ 6" TURN LANE DOTTED EXTENSIONS
- ⑨ 24" RAILROAD CROSSING TRAVERSE LINE
- ⑩ 16" RAILROAD CROSSING X LINE
- ⑪ 12" SCHOOL CROSSING
- ⑫ 4" SINGLE YELLOW MEDIAN OUTLINE

**NOTES**

LIMIT OF RESURFACING ON SIDE-STREETS THROUGH OUT THE IMPROVEMENT SHALL BE TO THE RADIUS OF RETURN OR AS DIRECTED BY THE ENGINEER.

ALL FINAL PAVEMENT MARKINGS SHALL BE THERMOPLASTIC (OF THE EXTRUDED TYPE) AND SHOULD BE PLACED IN ACCORDANCE WITH "DISTRICT ONE TYPICAL PAVEMENT MARKINGS" DETAIL, (TC-13).

ALL RAISED REFLECTIVE PAVEMENT MARKERS SHALL BE PLACED IN ACCORDANCE WITH THE DISTRICT ONE "TYPICAL APPLICATIONS RAISED REFLECTIVE PAVEMENT MARKER DETAIL" (TC-11).

REVISIONS	
NAME	DATE

ILLINOIS DEPARTMENT OF TRANSPORTATION  
**47th STREET FROM  
 EAST/EBERLY TO HARLEM AVE.  
 ROADWAY & PAVEMENT MARKING PLAN**

SCALE: VERT. 1"=50'  
 HORIZ. 1"=100'  
 DATE 3/20/2007

DRAWN BY  
 CHECKED BY

PLOT DATE = 3/20/2007  
 PLOT SCALE = 50.000000 / IN.  
 USER NAME = abraham

F.A.U. RTE.	SECTION	COUNTY	TOTAL SHEETS	SHEET NO.
1488	3212 RS-2	COOK	32	12
STA.		TO STA.		
FED. ROAD DIST. NO. 1		ILLINOIS	HIGHWAY PROJECT	

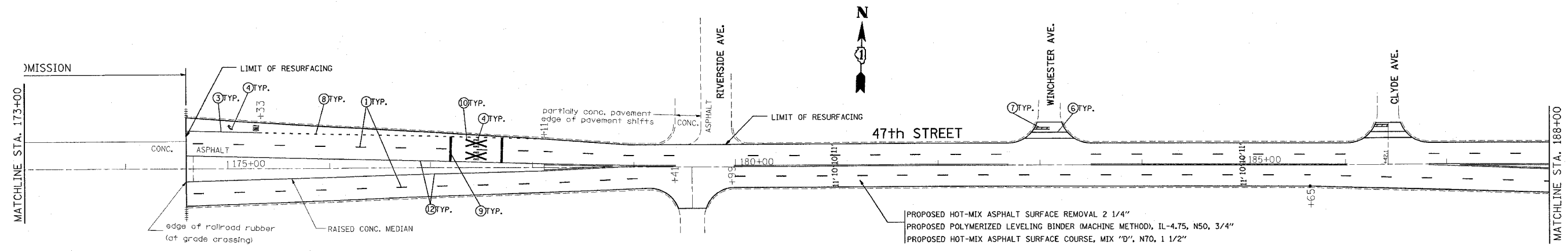
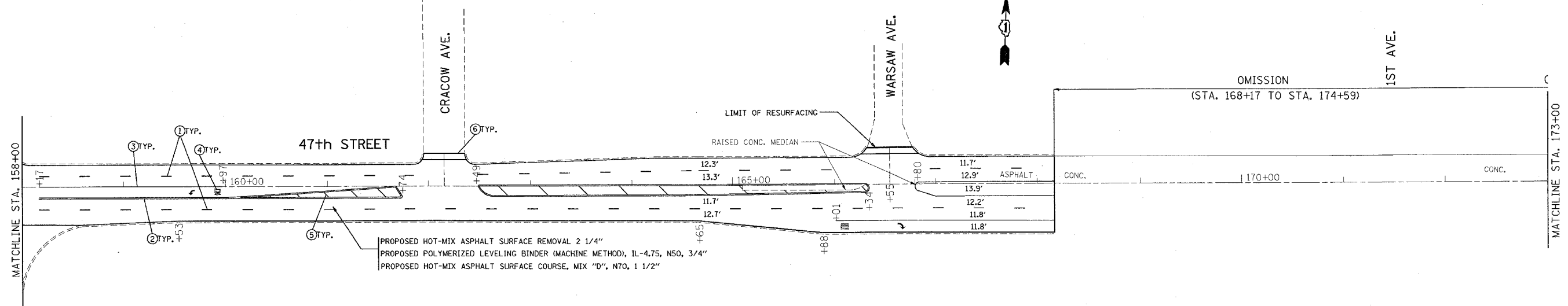

PROPOSED HOT-MIX ASPHALT SURFACE REMOVAL 2 1/4"  
 PROPOSED POLYMERIZED LEVELING BINDER (MACHINE METHOD), IL-4.75, N50, 3/4"  
 PROPOSED HOT-MIX ASPHALT SURFACE COURSE, MIX "D", N70, 1 1/2"

PROPOSED HOT-MIX ASPHALT SURFACE REMOVAL 2 1/4"  
 PROPOSED POLYMERIZED LEVELING BINDER (MACHINE METHOD), IL-4.75, N50, 3/4"  
 PROPOSED HOT-MIX ASPHALT SURFACE COURSE, MIX "D", N70, 1 1/2"

**PAVEMENT MARKING LEGEND**

- ① 4" LANE LINE- WHITE
- ② 4" DOUBLE YELLOW
- ③ 6" TURN LANE-WHITE
- ④ LETTERS & SYMBOLS-WHITE
- ⑤ 12" DIAGONALS-YELLOW @ 45°
- ⑥ 6" CROSS WALK-WHITE
- ⑦ 24" STOP BAR-WHITE
- ⑧ 6" TURN LANE DOTTED EXTENSIONS
- ⑨ 24" RAILROAD CROSSING TRAVERSE LINE
- ⑩ 16" RAILROAD CROSSING X LINE
- ⑪ 12" SCHOOL CROSSING
- ⑫ 4" SINGLE YELLOW MEDIAN OUTLINE

**NOTES**

LIMIT OF RESURFACING ON SIDE-STREETS THROUGH OUT THE IMPROVEMENT SHALL BE TO THE RADIUS OF RETURN OR AS DIRECTED BY THE ENGINEER.

ALL FINAL PAVEMENT MARKINGS SHALL BE THERMOPLASTIC (OF THE EXTRUDED TYPE) AND SHOULD BE PLACED IN ACCORDANCE WITH "DISTRICT ONE TYPICAL PAVEMENT MARKINGS" DETAIL, (TC-13).

ALL RAISED REFLECTIVE PAVEMENT MARKERS SHALL BE PLACED IN ACCORDANCE WITH THE DISTRICT ONE "TYPICAL APPLICATIONS RAISED REFLECTIVE PAVEMENT MARKER DETAIL," (TC-11).

REVISIONS	
NAME	DATE

ILLINOIS DEPARTMENT OF TRANSPORTATION  
**47th STREET FROM  
 EAST/EBERLY TO HARLEM AVE.  
 ROADWAY & PAVEMENT MARKING PLAN**  
 SCALE: VERT. 1"=50'  
 HORIZ. 1"=50'  
 DATE 3/20/2007  
 DRAWN BY  
 CHECKED BY

PLOT DATE = 3/20/2007  
 FILE NAME = c:\pcc\proj\1488\3212\rs-2\design\as.dgn  
 PLOT SCALE = 1/8"=1'-0"  
 USER NAME = abraham



F.A.U. RTE.	SECTION	COUNTY	TOTAL SHEETS	SHEET NO.
1488	3212 RS-2	COOK	32	14
STA.		TO STA.		
FED. ROAD DIST. NO. 1		ILLINOIS HIGHWAY PROJECT		

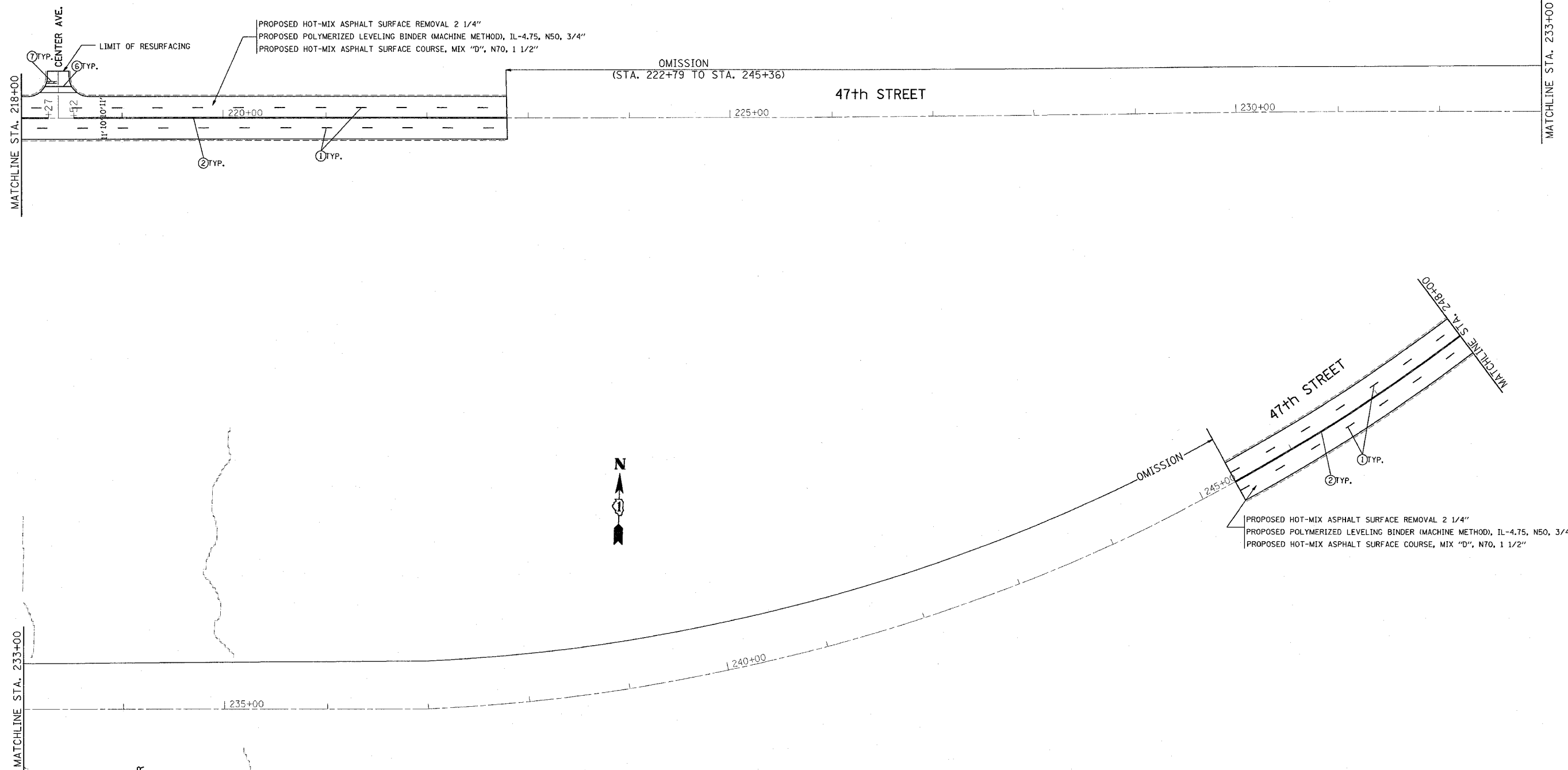

MATCHLINE STA. 233+00

DES PLAINES RIVER

- PAVEMENT MARKING LEGEND**
- ① 4" LANE LINE- WHITE
  - ② 4" DOUBLE YELLOW
  - ③ 6" TURN LANE-WHITE
  - ④ LETTERS & SYMBOLS-WHITE
  - ⑤ 12" DIAGONALS-YELLOW @ 45°
  - ⑥ 6" CROSS WALK-WHITE
  - ⑦ 24" STOP BAR-WHITE
  - ⑧ 6" TURN LANE DOTTED EXTENSIONS
  - ⑨ 24" RAILROAD CROSSING TRAVERSE LINE
  - ⑩ 16" RAILROAD CROSSING X LINE
  - ⑪ 12" SCHOOL CROSSING
  - ⑫ 4" SINGLE YELLOW MEDIAN OUTLINE

**NOTES**

LIMIT OF RESURFACING ON SIDE-STREETS THROUGH OUT THE IMPROVEMENT SHALL BE TO THE RADIUS OF RETURN OR AS DIRECTED BY THE ENGINEER.

ALL FINAL PAVEMENT MARKINGS SHALL BE THERMOPLASTIC (OF THE EXTRUDED TYPE) AND SHOULD BE PLACED IN ACCORDANCE WITH "DISTRICT ONE TYPICAL PAVEMENT MARKINGS" DETAIL, (TC-13).

ALL RAISED REFLECTIVE PAVEMENT MARKERS SHALL BE PLACED IN ACCORDANCE WITH THE DISTRICT ONE "TYPICAL APPLICATIONS RAISED REFLECTIVE PAVEMENT MARKER DETAIL." (TC-11).

REVISIONS	
NAME	DATE

ILLINOIS DEPARTMENT OF TRANSPORTATION

**47th STREET FROM EAST/EBERLY TO HARLEM AVE. ROADWAY & PAVEMENT MARKING PLAN**

SCALE: VERT. 1"=50'  
HORIZ. 1"=50'

DATE 3/20/2007

DRAWN BY  
CHECKED BY

PLOT DATE = 3/20/2007  
FILE NAME = c:\p\projects\108766\design\as.dgn  
PLOT SCALE = 50.0000' / IN.  
USER NAME = abraham

F.A.L. RTE.	SECTION	COUNTY	TOTAL SHEETS	SHEET NO.
1488	3212 RS-2	COOK	32	15
STA.		TO STA.		
FED. ROAD DIST. NO. 1		ILLINOIS	HIGHWAY PROJECT	

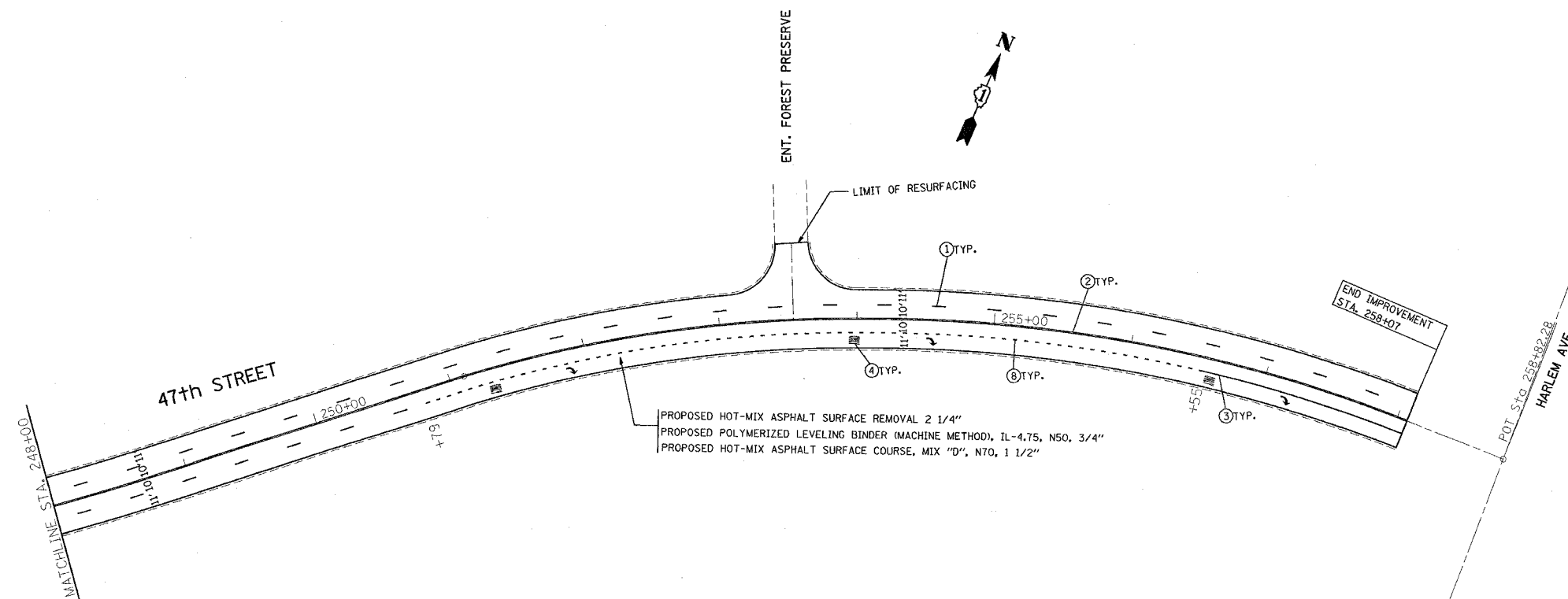

**PAVEMENT MARKING LEGEND**

- ① 4" LANE LINE- WHITE
- ② 4" DOUBLE YELLOW
- ③ 6" TURN LANE-WHITE
- ④ LETTERS & SYMBOLS-WHITE
- ⑤ 12" DIAGONALS-YELLOW @ 45°
- ⑥ 6" CROSS WALK-WHITE
- ⑦ 24" STOP BAR-WHITE
- ⑧ 6" TURN LANE DOTTED EXTENSIONS
- ⑨ 24" RAILROAD CROSSING TRAVERSE LINE
- ⑩ 16" RAILROAD CROSSING X LINE
- ⑪ 12" SCHOOL CROSSING
- ⑫ 4" SINGLE YELLOW MEDIAN OUTLINE

**NOTES**

LIMIT OF RESURFACING ON SIDE-STREETS THROUGH OUT THE IMPROVEMENT SHALL BE TO THE RADIUS OF RETURN OR AS DIRECTED BY THE ENGINEER.

ALL FINAL PAVEMENT MARKINGS SHALL BE THERMOPLASTIC (OF THE EXTRUDED TYPE) AND SHOULD BE PLACED IN ACCORDANCE WITH "DISTRICT ONE TYPICAL PAVEMENT MARKINGS" DETAIL, (TC-13).

ALL RAISED REFLECTIVE PAVEMENT MARKERS SHALL BE PLACED IN ACCORDANCE WITH THE DISTRICT ONE "TYPICAL APPLICATIONS RAISED REFLECTIVE PAVEMENT MARKER DETAIL." (TC-11).

REVISIONS	
NAME	DATE

ILLINOIS DEPARTMENT OF TRANSPORTATION

**47th STREET FROM EAST/EBERLY TO HARLEM AVE. ROADWAY & PAVEMENT MARKING PLAN**

SCALE: VERT. 1"=50'  
 HORIZ. 1"=50'  
 DATE 3/20/2007

DRAWN BY  
 CHECKED BY

PLOT DATE = 3/20/2007  
 FILE NAME = c:\p\projects\0106706\design\ee.dgn  
 PLOT SCALE = 5/8"=1' / IN.  
 USER NAME = adrean

		TRAFFIC SIGNAL LEGEND			
		PROPOSED	EXISTING	PROPOSED	EXISTING
CONTROLLER			G.S. CONDUIT IN TRENCH OR PUSHED		
SERVICE INSTALLATION			PEDESTRIAN PUSHBUTTON DETECTOR		
SIGNAL HEAD			DETECTOR LOOP		
SIGNAL HEAD WITH BACKPLATE			CAST IRON JUNCTION BOX		
SIGNAL HEAD, PEDESTRIAN			EMERGENCY VEHICLE SYSTEM DETECTOR		
SIGNAL POST			CONFIRMATION BEACON		
MAST ARM ASSEMBLY AND POLE, STEEL			SIGNAL HEAD OPTICALLY PROGRAMMED		
MAST ARM ASSEMBLY AND POLE, ALUMINUM			CONDUIT SPLICE		
COMMON TRENCH			WOOD POLE		
UNIT DUCT			RACEWAY FOR MAGNETIC DETECTOR, TYPE I OR TYPE II		
HANDHOLE			VEHICLE DETECTOR, NON-COMPENSATED MAGNETIC TYPE		
HEAVY DUTY HANDHOLE			RAILROAD CONTROL CABINET		
DOUBLE HANDHOLE					

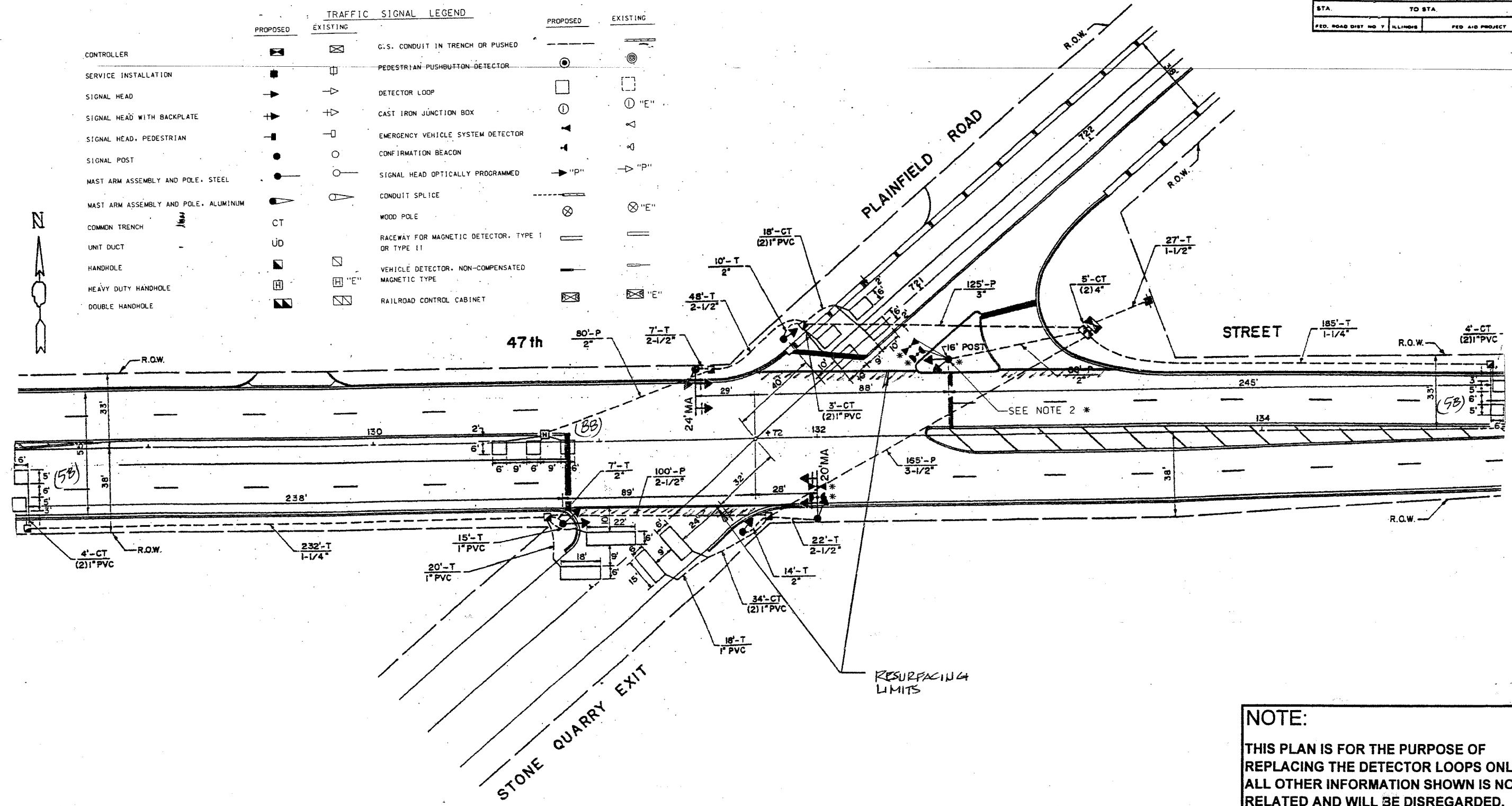

**NOTE:**  
 THIS PLAN IS FOR THE PURPOSE OF REPLACING THE DETECTOR LOOPS ONLY. ALL OTHER INFORMATION SHOWN IS NOT RELATED AND WILL BE DISREGARDED.

**REPLACE ALL DETECTOR LOOPS AS SHOWN**  
 (WITHIN THE RESURFACING LIMITS)

CODE NO.	QUANTITY	UNIT	ITEM
86600600	174	Foot	Detector Loop Replacement

REVISIONS	
NAME	DATE

ILLINOIS DEPARTMENT OF TRANSPORTATION  
**DETECTOR LOOP REPLACEMENT**  
 47TH ST. @ PLAINFIELD RD.  
 SCALE: NONE  
 DATE: JULY 06  
 DRAWN BY: JHE  
 DESIGNED BY: JHE  
 CHECKED BY: DAD



SECTION	COUNTY	TOTAL SHEETS	SHEET NO.
	Cook		17
STA. TO STA.		FED. ROAD DIST. NO. 7 ILLINOIS FED. AID PROJECT	

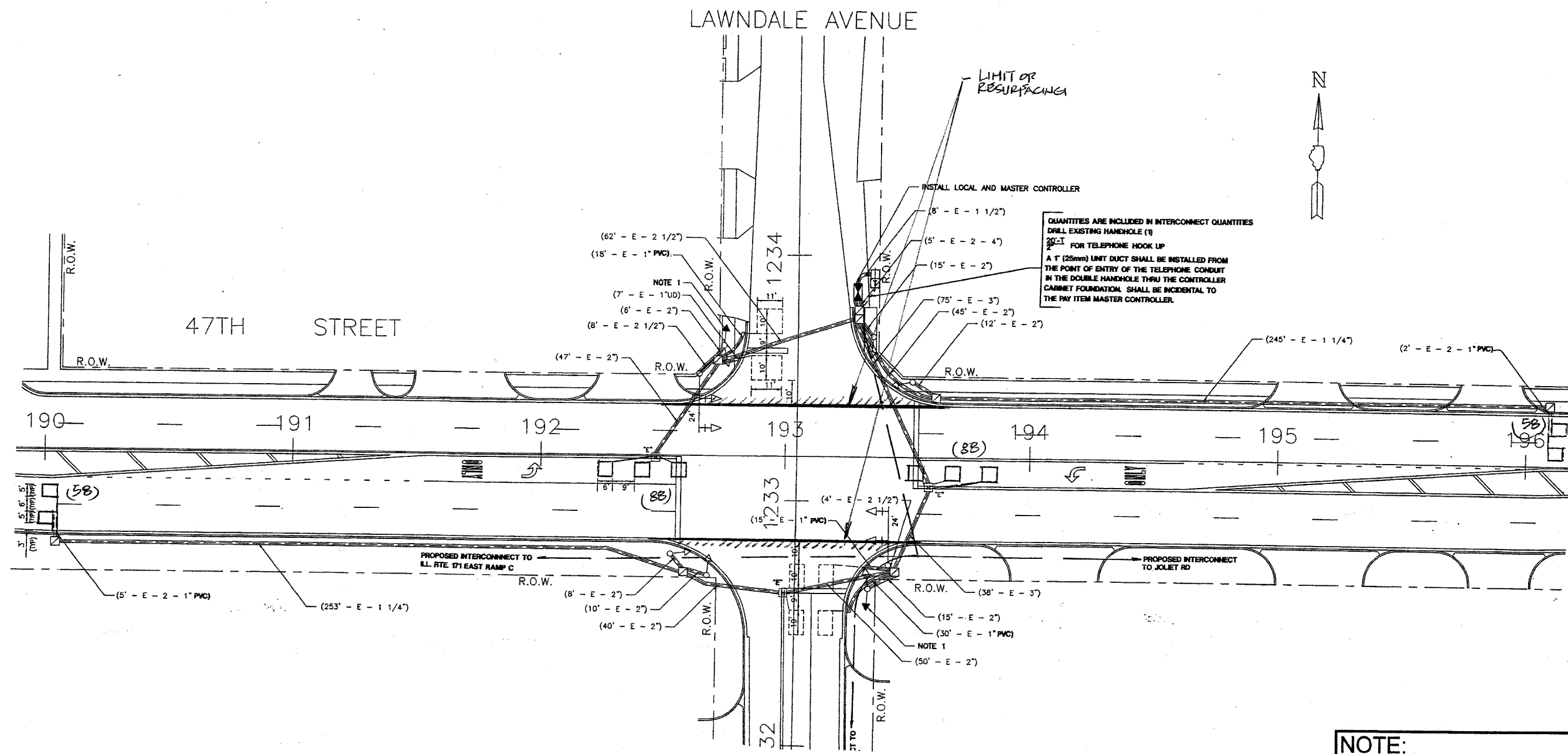

**NOTE:**  
 THIS PLAN IS FOR THE PURPOSE OF REPLACING THE DETECTOR LOOPS ONLY. ALL OTHER INFORMATION SHOWN IS NOT RELATED AND WILL BE DISREGARDED.

**REPLACE ALL DETECTOR LOOPS AS SHOWN**  
 (WITHIN THE RESURFACING LIMITS)

CODE NO.	QUANTITY	UNIT	ITEM
86600600	292	Foot	Detector Loop Replacement

REVISIONS	
NAME	DATE

ILLINOIS DEPARTMENT OF TRANSPORTATION  
**DETECTOR LOOP REPLACEMENT**  
 47TH ST @ LAWDALE AV.

SCALE: NONE  
 DATE: JULY 06

DRAWN BY: JHE  
 DESIGNED BY: JHE  
 CHECKED BY: DAD

SECTION	COUNTY	TOTAL SHEETS	SHEET NO.
	Cook		18
STA.		TO STA.	
FED. ROAD DIST NO 7 ILLINOIS		FED AID PROJECT	

JOLIET AVENUE

MATCH LINE STA. 238+00

JOLIET ROAD

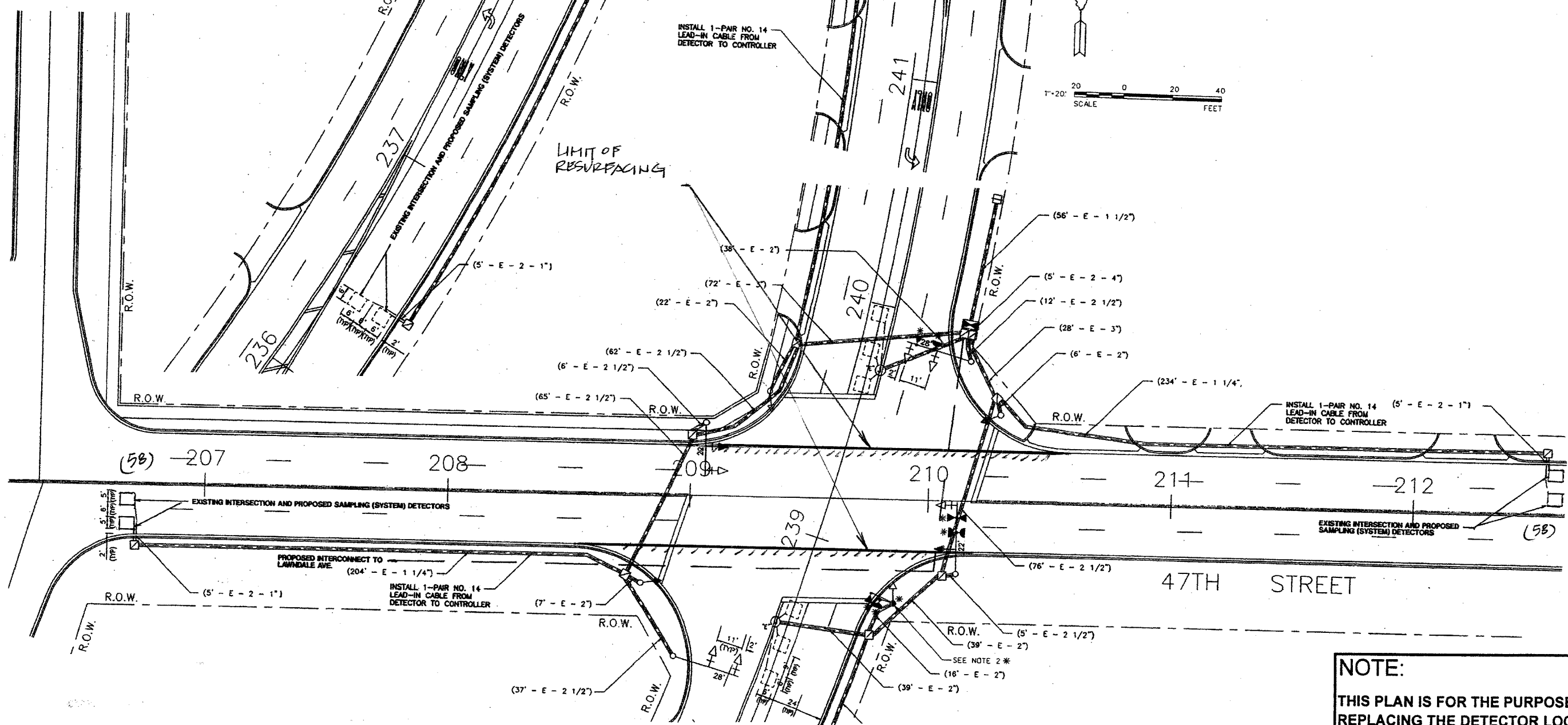
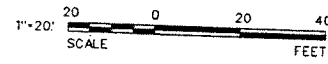

**NOTE:**  
 THIS PLAN IS FOR THE PURPOSE OF REPLACING THE DETECTOR LOOPS ONLY. ALL OTHER INFORMATION SHOWN IS NOT RELATED AND WILL BE DISREGARDED.

**REPLACE ALL DETECTOR LOOPS AS SHOWN**  
 (WITHIN THE RESURFACING LIMITS)

CODE NO.	QUANTITY	UNIT	ITEM
86600600	116	Foot	Detector Loop Replacement

REVISIONS	
NAME	DATE

ILLINOIS DEPARTMENT OF TRANSPORTATION  
**DETECTOR LOOP REPLACEMENT**  
 47TH ST. @ JOLIET RD.  
 SCALE: NONE  
 DATE: JULY 06  
 DRAWN BY: JHE.  
 DESIGNED BY: JHE.  
 CHECKED BY: DAD.

PLAN SHEET NO.	SECTION	COUNTY	TOTAL SHEETS	SHEET NO.
1488	3212 RS-2	COOK		18A
STA.		TO STA.		
FED. ROAD DIST. NO. 7		ILLINOIS		FED. AID PROJECT

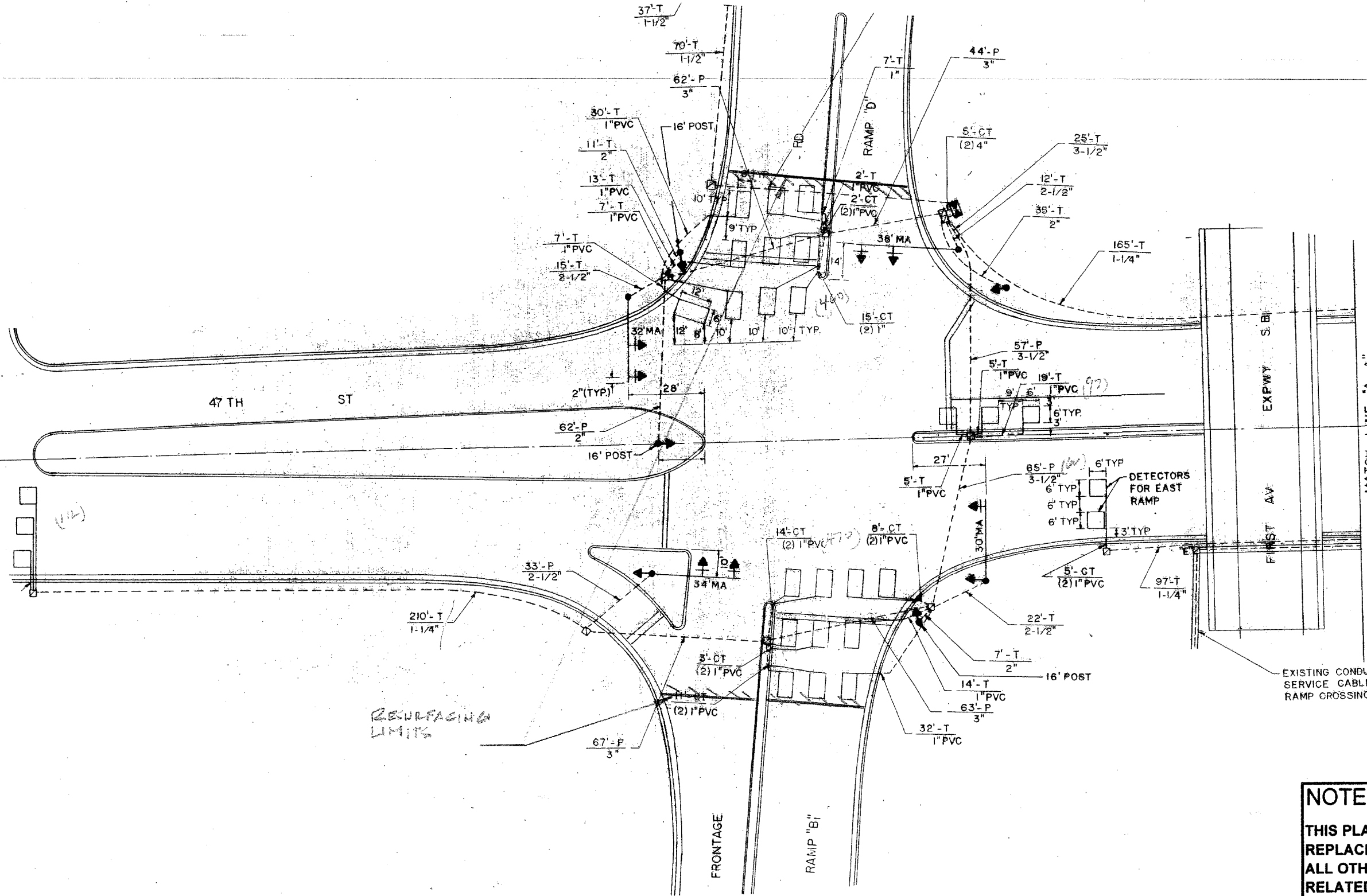

RESURFACING LIMITS

EXISTING CONDUIT AND SERVICE CABLE FEEDING RAMP CROSSING SIGNALS

**NOTE:**  
 THIS PLAN IS FOR THE PURPOSE OF REPLACING THE DETECTOR LOOPS ONLY. ALL OTHER INFORMATION SHOWN IS NOT RELATED AND WILL BE DISREGARDED.

**REPLACE ALL DETECTOR LOOPS AS SHOWN**

(WITHIN THE RESURFACING LIMITS)

CODE NO.	QUANTITY	UNIT	ITEM
86600600	1205	112 Foot	Detector Loop Replacement

REVISIONS	
NAME	DATE

ILLINOIS DEPARTMENT OF TRANSPORTATION  
**DETECTOR LOOP REPLACEMENT**  
 47TH ST. @ I-55 (W. RAMP)  
 SCALE: *AS SHOWN*  
 DATE: *MAR. 2007*  
 DRAWN BY: JHE  
 DESIGNED BY: JHE  
 CHECKED BY: D.A.D.



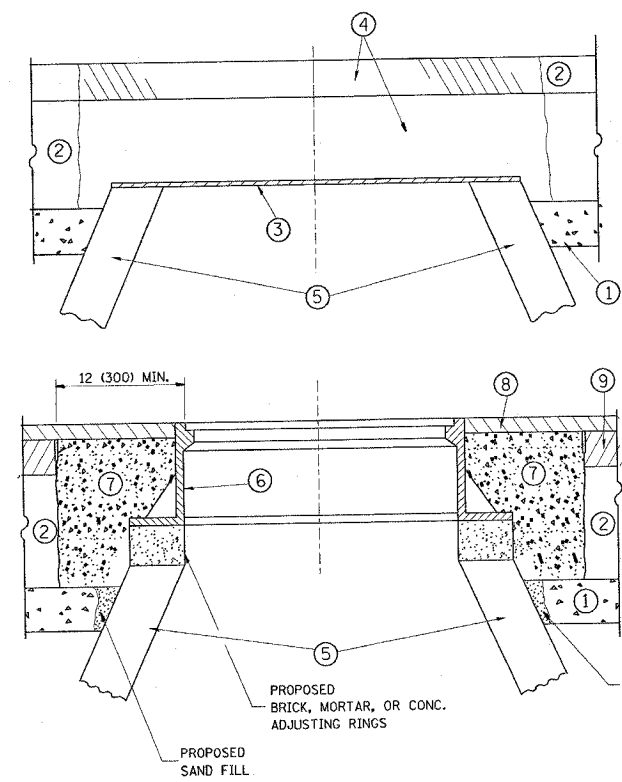

**CONSTRUCTION PROCEDURES**

**STAGE 1 (BEFORE PAVEMENT MILLING)**

- A) REMOVE A MINIMUM OF 12 (300) OF THE PAVEMENT FROM AROUND THE STRUCTURE.
- B) REMOVE THE EXISTING FRAME AND LID FROM THE STRUCTURE.
- C) COVER THE STRUCTURE OPENING WITH A 36 (900) DIAMETER METAL PLATE.
- D) BACKFILL WITH CRUSHED STONE AND A MINIMUM 1 1/2 (40) THICK HMA SURFACE MIX APPROVED BY THE ENGINEER.

**STAGE 2 (AFTER PAVEMENT MILLING)**

- A) REMOVE THE HMA SURFACE MIX AND CRUSHED STONE.
- B) INSTALL THE FRAME AND LID; ADJUST THE FRAME TO ITS FINAL SURFACE ELEVATION.
- C) THE SURROUNDING SPACE SHALL BE FILLED WITH CLASS SI CONCRETE, OR HMA SURFACE COURSE OR HMA BINDER COURSE TO THE ELEVATION OF THE SURFACE OF THE EXISTING BASE COURSE OR THE BINDER COURSE.

THE PROCEDURE EXPLAINED ABOVE SHALL CONFORM TO THE APPLICABLE PORTIONS OF SECTIONS 353, 406, 602, AND 603 OF THE STANDARD SPECIFICATIONS.

**LEGEND**

- |  |  |
|--|--|
| ① SUB-BASE GRANULAR MATERIAL                 | ⑥ FRAME AND LID (SEE NOTES)                                  |
| ② EXISTING PAVEMENT                          | ⑦ CLASS SI CONCRETE, HMA SURFACE COURSE OR HMA BINDER COURSE |
| ③ 36 (900) DIAMETER METAL PLATE              | ⑧ PROPOSED HMA SURFACE COURSE                                |
| ④ PROPOSED CRUSHED STONE AND HMA SURFACE MIX | ⑨ PROPOSED HMA BINDER COURSE                                 |
| ⑤ EXISTING STRUCTURE                         |  |

**LOCATION OF STRUCTURES:**

THE CONTRACTOR WILL BE REQUIRED TO KEEP A RECORD OF THE LOCATIONS OF THE BURIED STRUCTURES ACCORDING TO THE STATION AND DISTANCE LEFT OR RIGHT OF THE CENTERLINE OF PAVEMENT. UPON COMPLETION OF THE WORK, THE CONTRACTOR WILL DELIVER THE RECORD TO THE ENGINEER.

**BASIS OF PAYMENT:** THIS WORK WILL BE PAID FOR AT THE CONTRACT UNIT PRICE PER EACH FOR "FRAMES AND LIDS TO BE ADJUSTED, SPECIAL"

NEW FRAMES AND LIDS, WHEN SPECIFIED, WILL BE PAID FOR SEPARATELY.

**NOTES:**

EXISTING BROKEN FRAMES AND LIDS SHALL BE REMOVED AND DISPOSED OF BY THE CONTRACTOR AND SHALL BE REPLACED AS DIRECTED BY THE ENGINEER. REPLACEMENT FRAMES AND LIDS WILL BE PAID FOR IN ACCORDANCE WITH ARTICLE 109.04 OF THE STANDARD SPECIFICATIONS UNLESS A SEPARATE PAY ITEM HAS BEEN PROVIDED.

IF THE EXISTING LIDS ARE OPEN, THE FRAME WILL BE ADJUSTED TO THE ELEVATION OF THE MILLED PAVEMENT SURFACE PRIOR TO THE MILLING OPERATION. THE FRAME WILL NOT BE REMOVED AND COVERED BY THE METAL PLATE.

CITY OF CHICAGO CASTINGS ARE THE PROPERTY OF THE CITY AND THE CONTRACTOR SHALL NOTIFY THE CITY FOR REMOVAL AND DISPOSITION OF THE CASTINGS.

THE METAL PLATE USED TO COVER THE STRUCTURE SHALL REMAIN THE PROPERTY OF THE CONTRACTOR.

WHEN STRUCTURES ARE TO BE ADJUSTED OR RECONSTRUCTED, THE LOWERING AND RAISING OF THE FRAMES AND LIDS WILL NOT BE PAID FOR SEPARATELY BUT WILL BE INCLUDED IN THE COST OF THE CORRESPONDING PAY ITEM.

**DETAILS FOR FRAMES AND LIDS ADJUSTMENT WITH MILLING**

ALL DIMENSIONS ARE IN INCHES (MILLIMETERS) UNLESS OTHERWISE SHOWN

REVISIONS	
NAME	DATE
R. SHAH	10/25/94
R. SHAH	01/30/98
R. SHAH	03/10/98
A. ABBAS	03/21/97
R. WIEDEMAN	05/14/04
R. BORO	01/01/07

ILLINOIS DEPARTMENT OF TRANSPORTATION  
**DETAILS FOR FRAMES AND LIDS ADJUSTMENT WITH MILLING**

SCALE: VERT. NONE  
HORIZ.

DRAWN BY  
CHECKED BY

BD600-03 (8D-8)

PLOT DATE = 3/29/2007  
FILE NAME = 433903.dgn  
USER NAME = abraham

CONTRACT NO.			
F.A. RTE.	SECTION	COUNTY	TOTAL SHEETS
			20
STA.	TO STA.		
FED. ROAD DIST. NO. 1	ILLINOIS	FED. AID PROJECT	

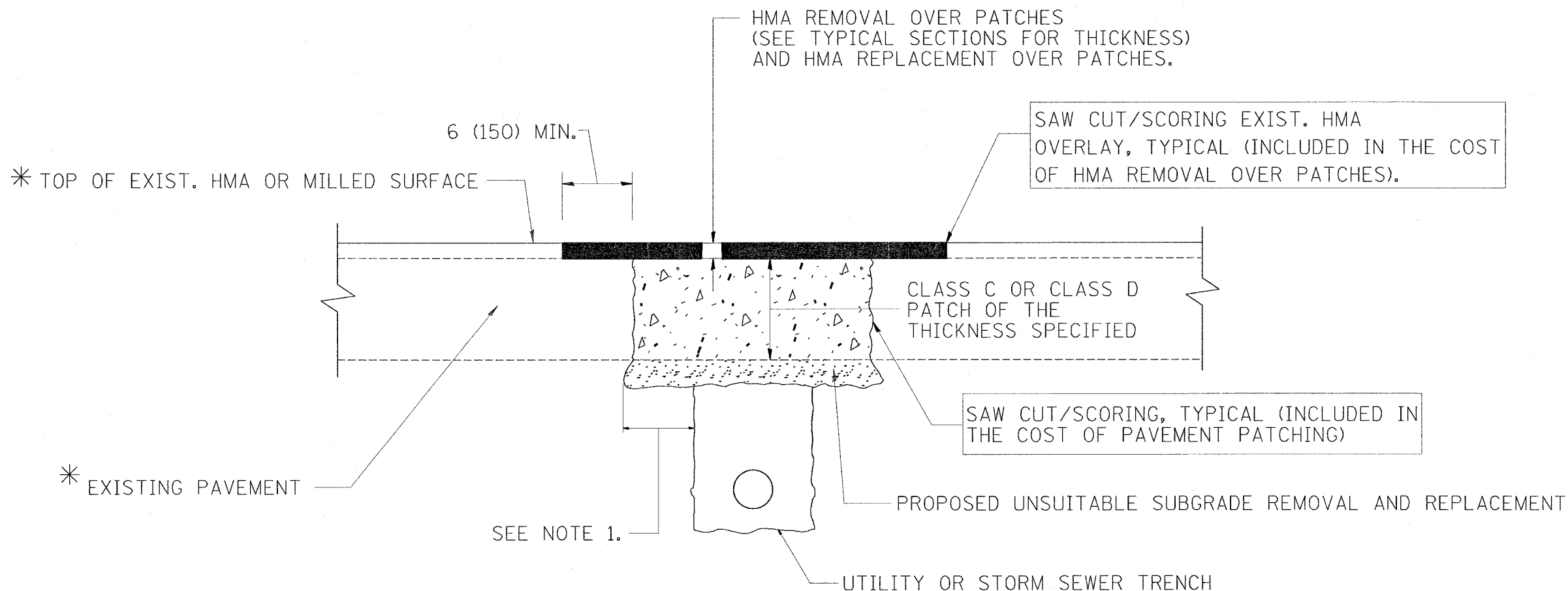

\* SEE TYPICAL SECTIONS FOR THICKNESS AND MATERIALS

**NOTES:**

1. THE WIDTH OF THE FULL DEPTH PATCH OVER A TRENCH SHALL BE 12 (300) WIDER ON EACH SIDE OF THE TRENCH.
2. FOR METHOD OF MEASUREMENT AND BASIS OF PAYMENT, SEE RECURRING SPECIAL PROVISION "PATCHING WITH HOT-MIX ASPHALT OVERLAY REMOVAL".

**SEQUENCE OF CONSTRUCTION**

1. REMOVE THE EXISTING HMA MATERIAL OVER THE AREA TO BE PATCHED.
2. REMOVE AND REPLACE FULL DEPTH PATCHES
3. REPLACE HMA MATERIAL OVER THE AREA TO BE PATCHED.

ALL DIMENSIONS ARE IN INCHES (MILLIMETERS) UNLESS OTHERWISE SHOWN.

REVISIONS	
NAME	DATE
R. SHAH	10/25/94
R. SHAH	01/14/95
R. SHAH	03/23/95
R. SHAH	04/24/95
A. HOUSEH	03/15/96
A. ABBAS	03/21/97
A. ABBAS	01/20/98
ART ABBAS	04/27/98
R. BORG	01/01/07

ILLINOIS DEPARTMENT OF TRANSPORTATION

**PAVEMENT PATCHING FOR HMA SURFACED PAVEMENT**

SCALE: VERT. NONE  
HORIZ. NONE

DRAWN BY  
CHECKED BY

BD400-04 (BD-22)

CONTRACT NO.				
F.A. RTE.	SECTION	COUNTY	TOTAL SHEETS	SHEET NO.
				21
STA.		TO STA.		
FED. ROAD DIST. NO. 1 ILLINOIS FED. AID PROJECT				

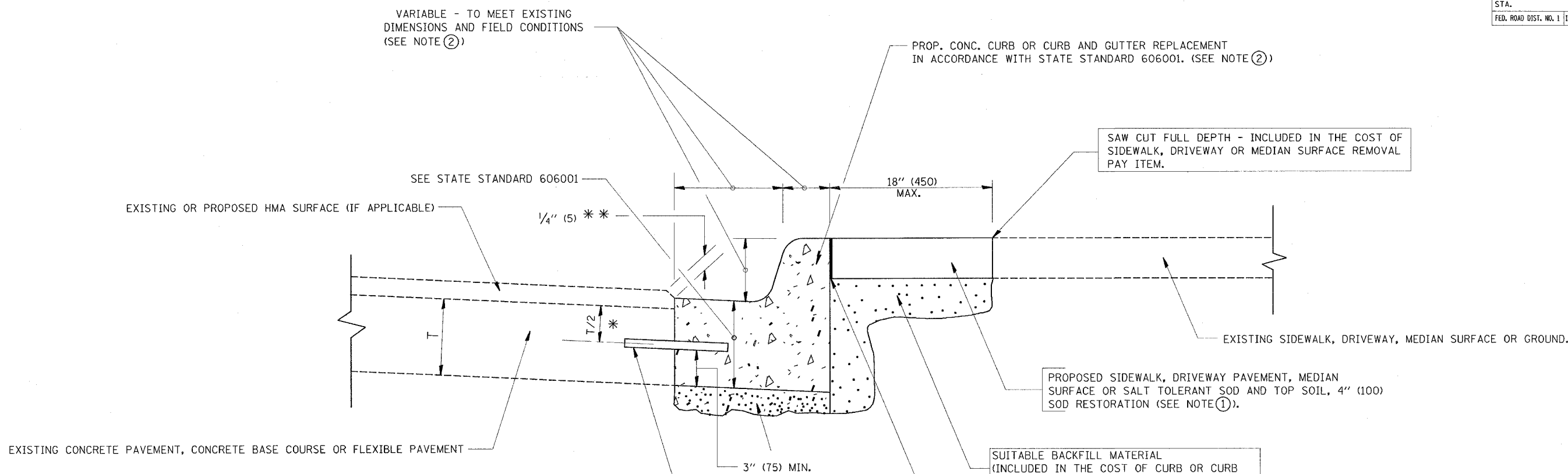

- \* 3" (75) MINIMUM FROM TOP AND BOTTOM OF THE CONCRETE PAVEMENT OR BASE COURSE.
- \*\* IF THE FINAL SURFACE OF THE PAVEMENT IS CONCRETE, THE GUTTER IS TO BE FLUSH WITH THE PAVEMENT.

NOTE: ① SIDEWALK, DRIVEWAY PAVEMENT OR MEDIAN SURFACE SHALL BE SIMILAR TO THE MATERIAL BEING REMOVED AND WILL BE PAID FOR SEPARATELY.

SALT TOLERANT SOD AND TOP SOIL, 4" (100) RESTORATION WILL NOT BE PAID FOR SEPARATELY, BUT SHALL BE INCLUDED IN THE COST OF CURB OR CURB AND GUTTER REMOVAL AND REPLACEMENT.

- ② CURB OR CURB AND GUTTER REPLACEMENT SHALL MATCH THE SHAPE OF THE EXISTING CURB OR CURB AND GUTTER UNLESS OTHERWISE SPECIFIED.
- ③ FOR CURB OR CURB AND GUTTER REMOVAL AND REPLACEMENT ADJACENT TO FLEXIBLE PAVEMENT DELETE EPOXY COATED TIE BARS.
- ④ LONGITUDINAL BARS, IF ENCOUNTERED IN THE EXISTING CURB OR CURB AND GUTTER, ARE NOT TO BE REPLACED. CUTTING AND REMOVING LONGITUDINAL BARS SHALL BE INCLUDED IN THE COST OF CURB OR CURB AND GUTTER REMOVAL AND REPLACEMENT.
- ⑤ THE COST OF HMA SURFACE REMOVAL IN THE EXISTING GUTTER FLAG SHALL BE INCLUDED IN THE COST OF THE CURB AND GUTTER REMOVAL AND REPLACEMENT.
- ⑥ THE REMOVAL AND REPLACEMENT OF THE EXISTING CURB OR CURB AND GUTTER SHALL BE DONE IN ACCORDANCE WITH THE APPLICABLE PORTIONS OF SECTION 440 AND 606 OF THE STANDARD SPECIFICATIONS.
- ⑦ THE LOCATIONS OF REMOVAL AND REPLACEMENT OF EXISTING CURB OR CURB AND GUTTER SHALL BE DETERMINED BY THE RESIDENT ENGINEER AT THE TIME OF CONSTRUCTION.

**BASIS OF PAYMENT:**  
 THIS WORK WILL BE PAID FOR AT THE CONTRACT UNIT PRICE PER FOOT (METER) FOR "CURB REMOVAL AND REPLACEMENT" OR "COMBINATION CONCRETE CURB AND GUTTER REMOVAL AND REPLACEMENT".

ALL DIMENSIONS ARE IN INCHES (MILLIMETERS) UNLESS OTHERWISE SHOWN.

REVISIONS	
NAME	DATE
A. HOUSEH	03/11/94
R. SHAH	02/24/95
R. SHAH	03/02/95
R. SHAH	08/19/96
R. SHAH	09/12/96
R. SHAH	09/19/96
R. SHAH	10/03/96
A. ABBAS	03/21/97
M. GOMEZ	01/22/01
R. BORO	01/01/07

ILLINOIS DEPARTMENT OF TRANSPORTATION

CURB OR CURB AND GUTTER REMOVAL AND REPLACEMENT

SCALE: VERT. NONE  
 HORIZ.

DRAWN BY  
 CHECKED BY  
 BD600-06 (BD-24)

CURB OR CURB AND GUTTER REMOVAL AND REPLACEMENT

PLOT DATE = 3/20/2007  
 FILE NAME = W:\data\bd600-06.dgn  
 PLOT SCALE = 50/800 / IN.  
 USER NAME = adrean

CONTRACT NO.			
F.A. RTE.	SECTION	COUNTY	TOTAL SHEET NO.
			22
STA.		TO STA.	
FED. ROAD DIST. NO. 1 ILLINOIS FED. AID PROJECT			

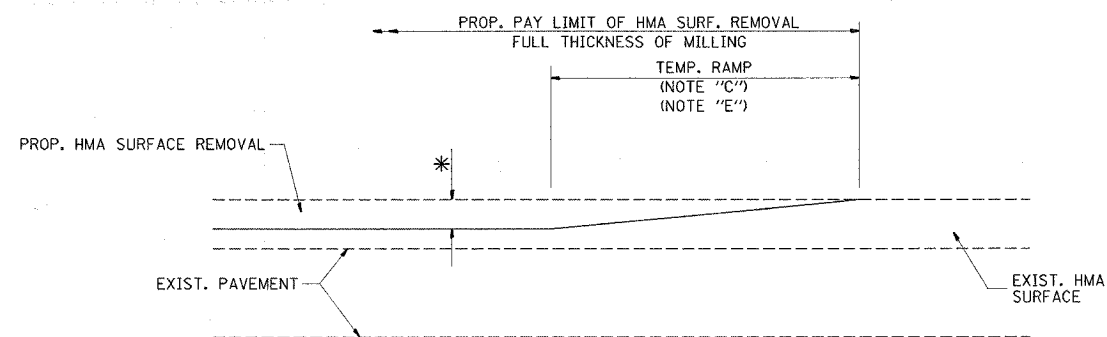

MILLED TEMPORARY RAMP  
(FOR BUTT JOINT AND HMA TAPER SEE DETAIL BELOW)

**OPTION 1**

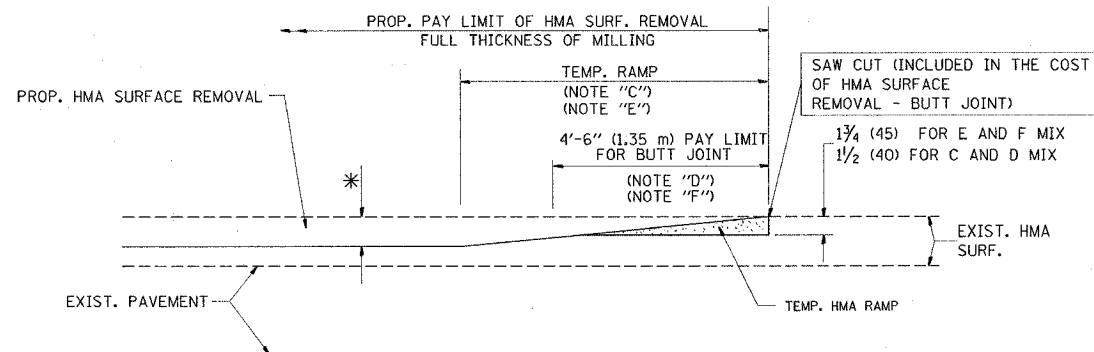

HMA CONSTRUCTED TEMPORARY RAMP  
(FOR BUTT JOINT AND HMA TAPER SEE DETAIL BELOW)

**OPTION 2**

**TYPICAL TEMPORARY RAMP**

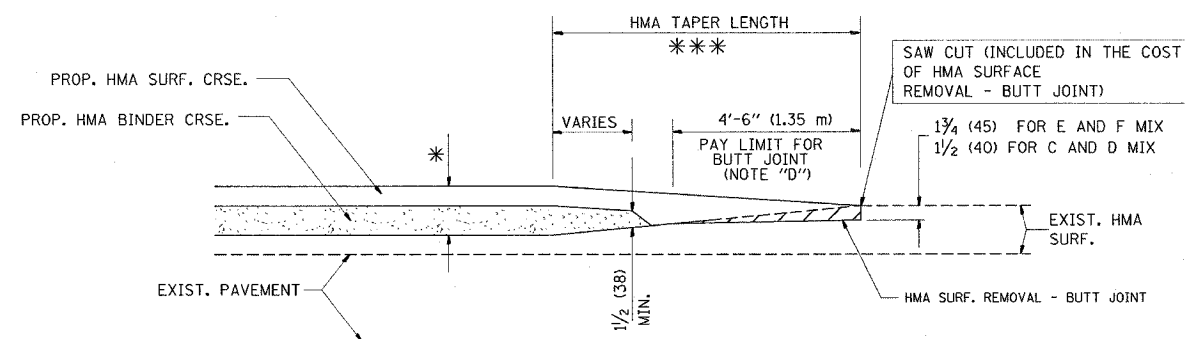

BUTT JOINT AND  
HMA TAPER

**TYPICAL BUTT JOINT AND HMA TAPER  
FOR MILLING AND RESURFACING**

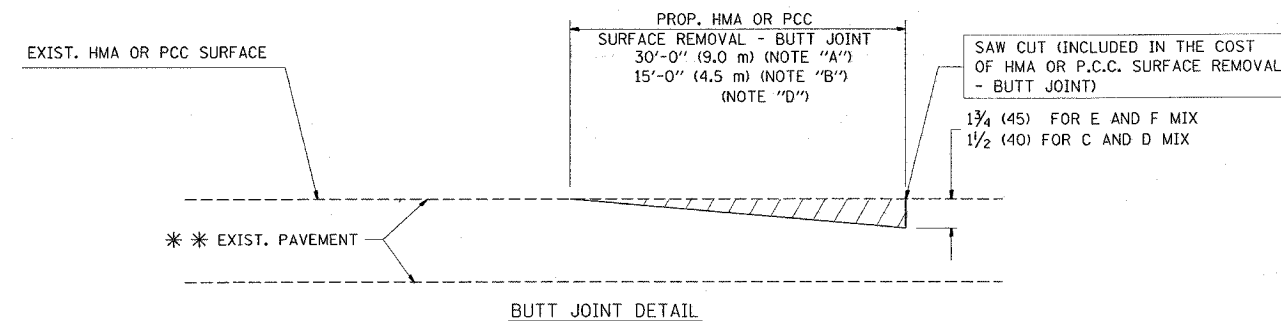

BUTT JOINT DETAIL

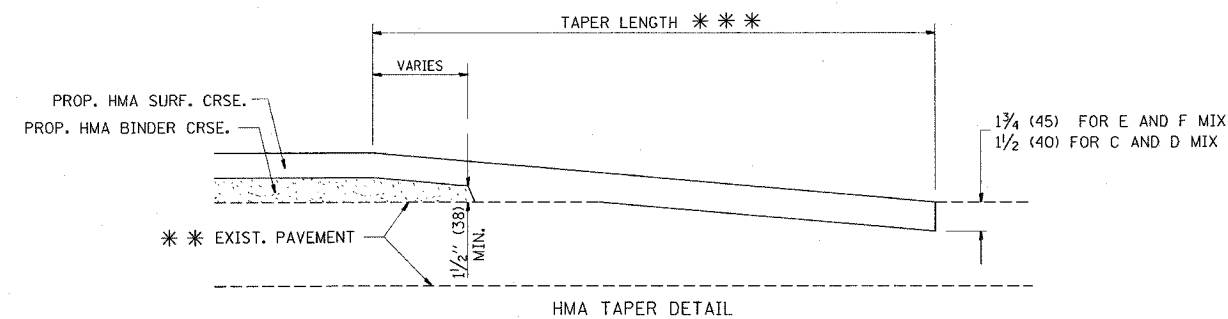

HMA TAPER DETAIL

**TYPICAL BUTT JOINT AND HMA TAPER  
FOR RESURFACING ONLY**

\*\*\* PC CONCRETE, HMA OR HMA RESURFACED PAVEMENT.

**NOTES**

- A: MAINLINE ROADWAYS AND MAJOR SIDE ROADS.
  - B: MINOR SIDE ROADS.
  - C: THE TEMP. RAMP SHALL BE CONSTRUCTED IMMEDIATELY UPON REMOVAL OF THE EXISTING HMA SURFACE.
  - D: THE BUTT JOINT SHALL BE CONSTRUCTED IMMEDIATELY PRIOR TO PLACING THE PROPOSED HMA COURSES.
  - E: TAPER THE TEMP. RAMP AT A RATE OF 3'-0" (900 mm) PER 1 INCH (25 mm) OF MILLING THICKNESS.
  - F: INSTALLATION AND REMOVAL OF THE 4'-6" (1.35 m) TEMP. RAMP IS INCLUDED IN COST OF HMA SURFACE REMOVAL - BUTT JOINT
  - G: SEE ARTICLE 406.08 AND 406.14 OF THE STANDARD SPECIFICATIONS FOR "HMA AND/OR PCC SURFACE REMOVAL, BUTT JOINT".
- \* SEE TYPICAL SECTIONS FOR MILLING THICKNESS.
- \*\*\* 20'-0" (6.1 m) PER 1 (25) RESURFACING (NOTE "A")  
10'-0" (3.0 m) PER 1 (25) RESURFACING (NOTE "B")

ALL DIMENSIONS ARE IN INCHES (MILLIMETERS) UNLESS OTHERWISE SHOWN.

**BASIS OF PAYMENT:**

THE BUTT JOINT WILL BE PAID FOR AT THE CONTRACT UNIT PRICE PER SQUARE YARD (SQUARE METER) FOR "HOT-MIX ASPHALT SURFACE REMOVAL - BUTT JOINT" OR FOR "PORTLAND CEMENT CONCRETE SURFACE REMOVAL - BUTT JOINT".

REVISIONS	
NAME	DATE
M. DE YONG	6-13-90
M. DE YONG	7-3-90
M. DE YONG	3-27-92
R. SHAH	09/09/94
R. SHAH	10/25/94
A. ABBAS	03/21/97
M. GOMEZ	04/06/01
R. BORO	01/01/07

ILLINOIS DEPARTMENT OF TRANSPORTATION

**BUTT JOINT AND  
HMA TAPER  
DETAILS**

SCALE: VERT. NONE  
HORIZ.

DRAWN BY  
CHECKED BY

BD400-05 (VI-BD32)



CONTRACT NO.			
F.A. RTE.	SECTION	COUNTY	TOTAL SHEETS
			23
SHEET NO.			
STA.	TO STA.		
FED. ROAD DIST. NO.	ILLINOIS	FED. AID PROJECT	

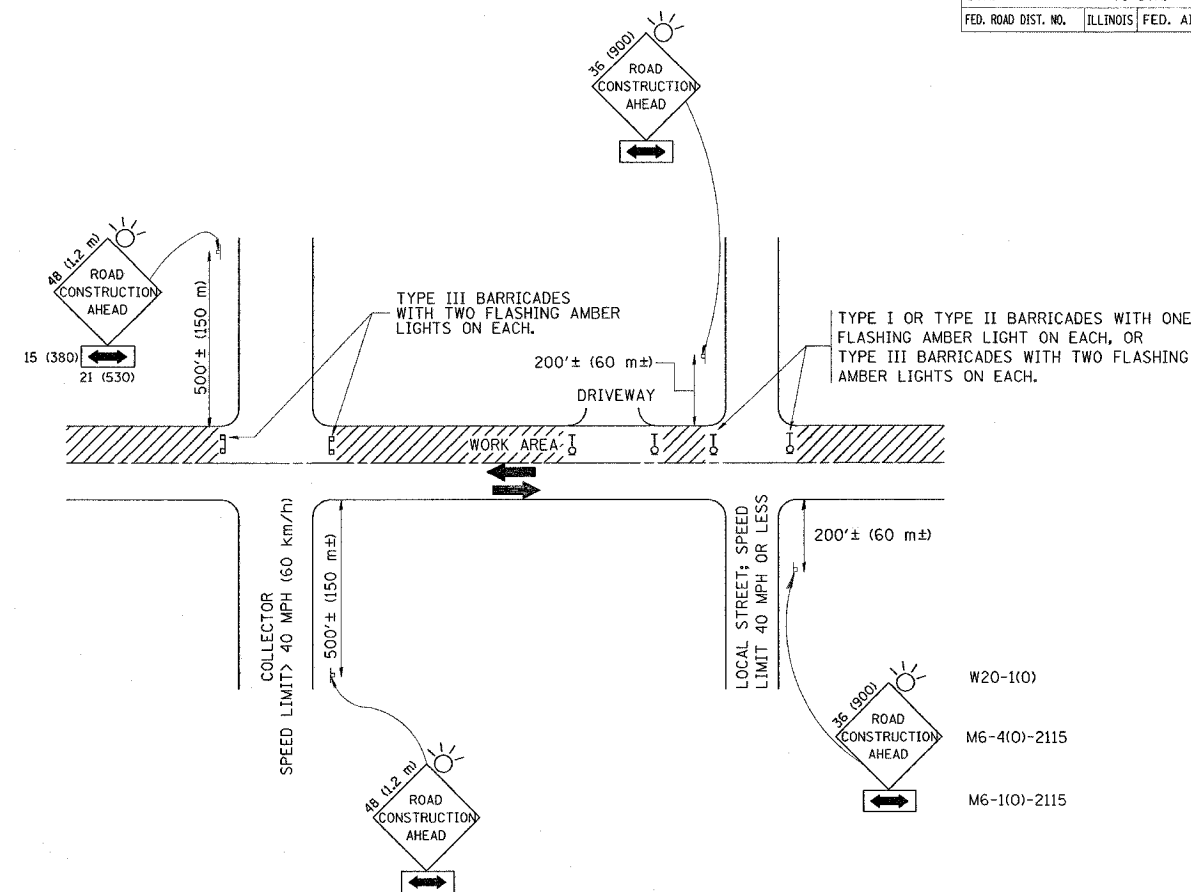

### TRAFFIC CONTROL AND PROTECTION FOR SIDE ROADS, INTERSECTIONS, AND DRIVEWAYS

#### NOTES:

- A. FOR NO LANE RESTRICTION ON THE SIDE ROAD OR DRIVEWAYS**
- SIDE ROAD WITH A SPEED LIMIT OF 40 MPH (60 km/h) OR LESS AS SHOWN ON THE DRAWING AND AS DIRECTED BY THE ENGINEER:
    - ONE ROAD CONSTRUCTION AHEAD SIGN 36 x 36 (900x900) WITH A FLASHER AND FLAG MOUNTED ON IT APPROXIMATELY 200' (60 m) IN ADVANCE OF THE MAIN ROUTE.
    - THE CLOSED PORTION OF THE MAIN ROUTE SHALL BE PROTECTED BY BLOCKING WITH TYPE I, TYPE II OR TYPE III BARRICADES, 1/3 OF THE CROSS SECTION OF THE CLOSED PORTION.
  - SIDE ROAD WITH A SPEED LIMIT GREATER THAN 40 MPH (60 km/h) AS SHOWN ON THE DRAWING AND AS DIRECTED BY THE ENGINEER:
    - ONE ROAD CONSTRUCTION AHEAD SIGN 48 x 48 (1.2 m x 1.2 m) WITH A FLASHER MOUNTED ON IT APPROXIMATELY 500' (150 m) IN ADVANCE OF THE MAIN ROUTE.
    - THE CLOSED PORTION OF THE MAIN ROUTE SHALL BE PROTECTED BY BLOCKING WITH TYPE III BARRICADES, 1/2 OF THE CROSS SECTION OF THE CLOSED PORTION.
  - WHEN THE SIDE ROAD LIES BETWEEN THE BEGINNING OF THE MAINLINE SIGNING AND THE WORK ZONE, A SINGLE HEADED ARROW (M6-1) SHALL BE USED IN LIEU OF THE DOUBLE HEADED ARROW (M6-4).
- B. FOR A LANE CLOSURE ON A SIDE ROAD OR DRIVEWAY:**
- USE APPLICABLE PORTIONS OF THE TYPICAL APPLICATION OF TRAFFIC CONTROL DEVICES (STD. 701501, STD. 701606 OR THE APPROPRIATE STANDARD). THE SPACING OF SIGNS AND BARRICADES SHALL BE ADJUSTED FOR FIELD CONDITIONS AS DIRECTED BY THE ENGINEER. THE DIRECTIONAL ARROW SHALL BE COVERED OR REMOVED WHEN NO LONGER CONSISTENT WITH THE SIDE ROAD LANE CLOSURE.
- C. ADVANCE WARNING SIGNS ARE TO BE OMITTED ON DRIVEWAY UNLESS OTHERWISE NOTED.**
- D. THE TRAFFIC CONTROL AND PROTECTION FOR SIDE ROADS, INTERSECTIONS, AND DRIVEWAYS SHALL BE INCIDENTAL TO THE COST OF SPECIFIED TRAFFIC CONTROL STANDARDS OR ITEMS.**

All dimensions are in millimeters (inches) unless otherwise shown.

REVISIONS	
NAME	DATE
LHA	6/89
T. RAMMACHER	09/08/94
J. OBERLE	10/18/95
A. HOUSEH	03/06/96
A. HOUSEH	10/15/96
T. RAMMACHER	01/06/00

ILLINOIS DEPARTMENT OF TRANSPORTATION  
**TRAFFIC CONTROL AND PROTECTION FOR SIDE ROADS, INTERSECTIONS, AND DRIVEWAYS**

SCALE: NONE

DRAWN BY  
 CHECKED BY

TC-10

PLOT DATE = 3/28/2007  
 FILE NAME = n:\ndstrsd\vol10\10.dgn  
 USER = jrb  
 USER PLOT = jrb

CONTRACT NO.				
F.A. RTE.	SECTION	COUNTY	TOTAL SHEETS	SHEET NO.
				24
STA.		TO STA.		
FED. ROAD DIST. NO.	ILLINOIS	FED. AID PROJECT		

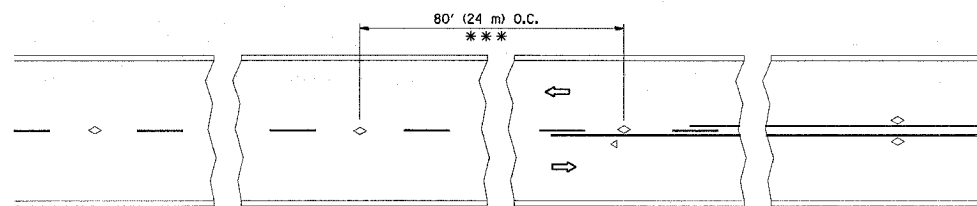

\*\*\* REDUCE TO 40' (12 m) O.C. ON CURVES WITH POSTED OR ADVISORY SPEED 45 M.P.H. (70 km/h) OR LESS.

TWO-LANE/TWO-WAY

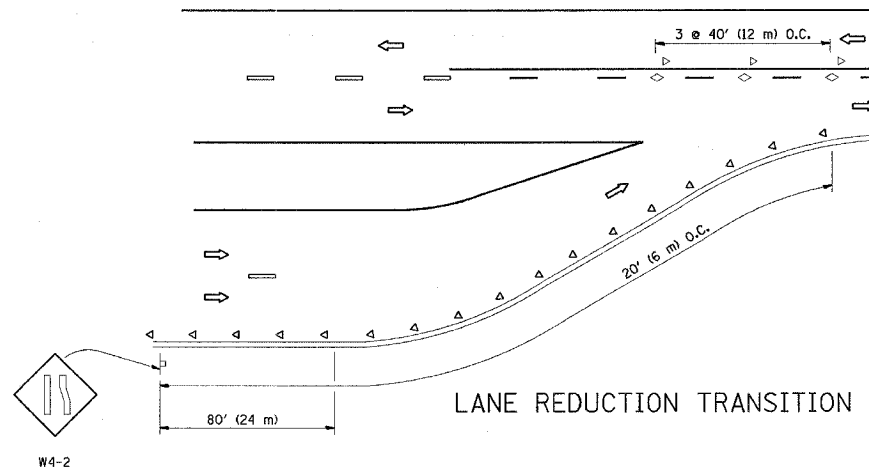

LANE REDUCTION TRANSITION

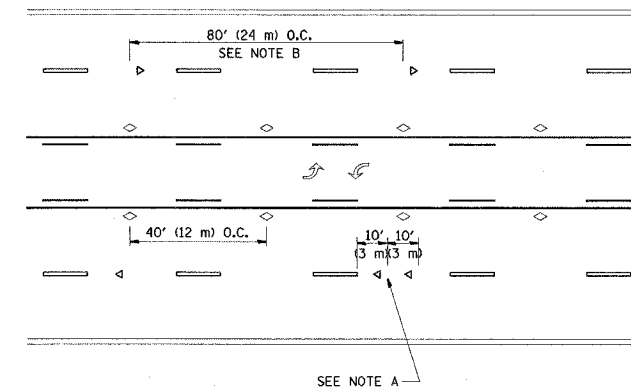

TWO-WAY LEFT TURN

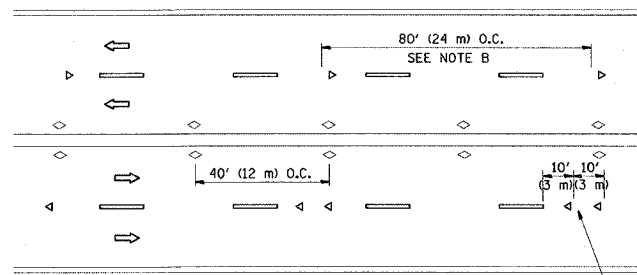

MULTI-LANE/UNDIVIDED

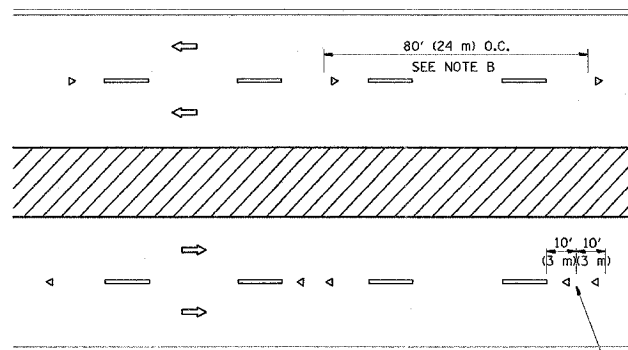

MULTI-LANE/DIVIDED

GENERAL NOTES

1. MARKERS USED WITH DASHED LINES SHALL BE CENTERED IN THE GAP BETWEEN SEGMENTS.
2. MARKERS USED ADJACENT TO SOLID LINES SHALL BE OFFSET 2 TO 3 (50 TO 75) TOWARD TRAFFIC AS SHOWN.
3. MARKERS THROUGH TANGENTS LESS THAN 500' (150 m) IN LENGTH BETWEEN CURVES SHALL BE INSTALLED AT THE LESSER OF THE TWO CURVE SPACINGS.

LANE MARKER NOTES

B. REDUCE TO 40' (12 m) O.C. ON CURVES WHERE ADVISORY SPEEDS ARE 10 M.P.H. (20 km/h) LOWER THAN POSTED SPEEDS.

A. USE DOUBLE LANE LINE MARKERS SPACED AS SHOWN.

SYMBOLS

- YELLOW STRIPE
- WHITE STRIPE
- ◁ ONE-WAY AMBER MARKER
- ◁ ONE-WAY CRYSTAL MARKER (W/O)
- ◇ TWO-WAY AMBER MARKER

DESIGN NOTES

1. DOUBLE LANE LINE MARKERS SHALL BE USED UNLESS SPECIFIED OTHERWISE.
2. EXCEPT AS SHOWN ON THE LANE REDUCTION TRANSITION AND FREEWAY EXIT RAMP DETAIL, MARKERS ARE NOT TO BE SPECIFIED ON RIGHT EDGE LINES.
3. THE EXACT MARKER LIMITS, SPACING, AND COLOR SHOULD BE INCLUDED IN THE PLANS.
4. MARKERS SHOULD NOT BE USED ALONGSIDE CURBS EXCEPT FOR EXTREMELY SHORT SECTIONS OF CURBS WHERE NOT MORE THAN TWO MARKERS WOULD BE INVOLVED.

All dimensions are in inches (millimeters) unless otherwise shown.

REVISIONS	
NAME	DATE
T. RAMMACHER	09-19-94
T. RAMMACHER	03-12-99
T. RAMMACHER	01-06-00

ILLINOIS DEPARTMENT OF TRANSPORTATION  
 TYPICAL APPLICATIONS  
 RAISED REFLECTIVE PAVEMENT  
 MARKERS (SNOW-PLOW RESISTANT)

SCALE: NONE

DRAWN BY CADD  
 CHECKED BY  
 TC-11

PLOT DATE = 3/28/2007  
 FILE NAME = w:\dallas\coll.dgn  
 PLOT SCALE = 50.000 / 1.000  
 USER NAME = dcoll

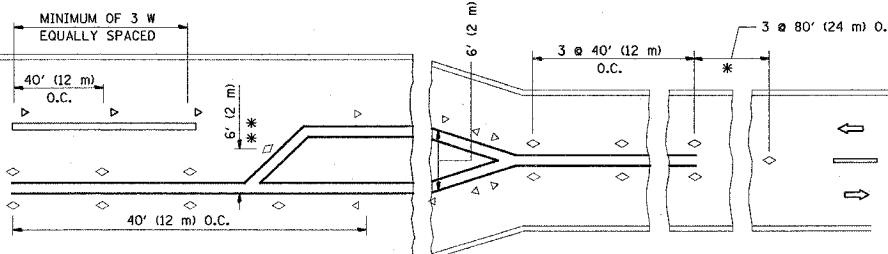

LEFT TURN

\* SEE TWO-LANE/TWO-WAY WHERE MARKERS CONTINUE  
 \*\* WHERE THE MEDIAN WIDTH IS 6' (2 m) OR LESS USE TWO-WAY MARKERS.





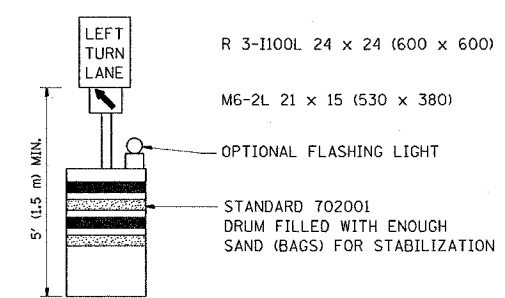
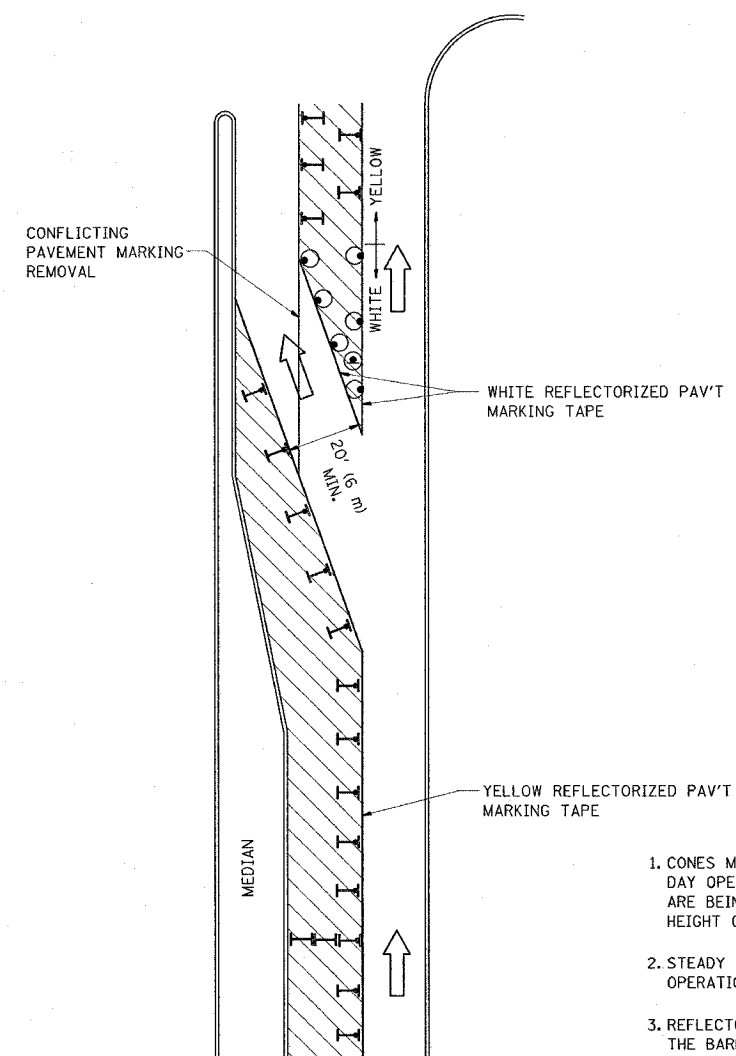



CONTRACT NO.			
F.A. RTE.	SECTION	COUNTY	TOTAL SHEETS
			26
STA.		TO STA.	
FED. ROAD DIST. NO.	ILLINOIS	FED. AID PROJECT	



**GENERAL NOTES**

1. CONES MAY BE SUBSTITUTED FOR BARRICADES OR DRUMS AT HALF THE SPACING DURING DAY OPERATIONS. CONES SHALL BE A MINIMUM OF 28 (710) IN HEIGHT. WHEN CONES ARE BEING USED, THE "LEFT TURN LANE" SIGN MAY BE SKID MOUNTED AT A MINIMUM HEIGHT OF 5' (1.5 m).
2. STEADY BURNING LIGHTS WILL NOT BE REQUIRED ON BARRICADES OR DRUMS FOR DAY OPERATIONS. ALL LIGHTS SHALL BE MONODIRECTIONAL.
3. REFLECTORIZED TEMPORARY PAVEMENT MARKING TAPE SHALL BE PLACED THROUGHOUT THE BARRICADED AREA OF EACH TURN BAY WHERE THE CLOSURE TIME IS GREATER THAN FOURTEEN DAYS.
4. THIS APPLICATION ALSO APPLIES WHEN WORK IS BEING PERFORMED IN THE RIGHT LANE(S) AND THE RIGHT TURN BAY IS TO REMAIN OPEN. UNDER THIS CONDITION, "RIGHT TURN LANE" R3-100 24 x 24 (600 x 600) AND M6-2R 21 x 15 (530 x 380) SHALL BE USED.
5. THESE CONTROLS SHALL SUPPLEMENT MAINLINE TRAFFIC CONTROL FOR LANE CLOSURES.
6. LONGITUDINAL DIMENSIONS MAY BE ADJUSTED TO FIT FIELD CONDITIONS.
7. FORM BT 725 IS REQUIRED.
8. TRAFFIC CONTROL AND PROTECTION AT TURN BAYS (TO REMAIN OPEN TO TRAFFIC) SHALL BE INCLUDED IN THE COST SPECIFIED TRAFFIC CONTROL STANDARDS OR ITEMS.

**LEGEND**

-  WORK AREA
-  LANE OPEN TO TRAFFIC
-  TYPE I OR II BARRICADE WITH STEADY BURN LIGHT
-  DRUM WITH STEADY BURN LIGHT
-  DRUM WITH SIGN (WITH OPTIONAL FLASHING LIGHT) SEE DETAIL
-  TYPE I OR II CHECK BARRICADE WITH FLASHING LIGHT

All dimensions are in inches (millimeters) unless otherwise shown.

REVISIONS	
NAME	DATE
T. RAMMACHER	09/08/94
A. HOUSEH	11/07/95
A. HOUSEH	10/12/96
T. RAMMACHER	01/06/00

ILLINOIS DEPARTMENT OF TRANSPORTATION  
**TRAFFIC CONTROL AND PROTECTION  
 AT TURN BAYS  
 (TO REMAIN OPEN TO TRAFFIC)**

SCALE: NONE  
 DRAWN BY  
 CHECKED BY LHA  
 TC-14

PLOT DATE = 3/20/2007  
 FILE NAME = \\n\users\ad\scf4.dgn  
 PLOT SCALE = 45/9999 / IN.  
 USER NAME = abreugh







CONTRACT NO.			
F.A. RTE.	SECTION	COUNTY	TOTAL SHEETS
			30
STA.		TO STA.	
FED. ROAD DIST. NO.	ILLINOIS	FED. AID PROJECT	

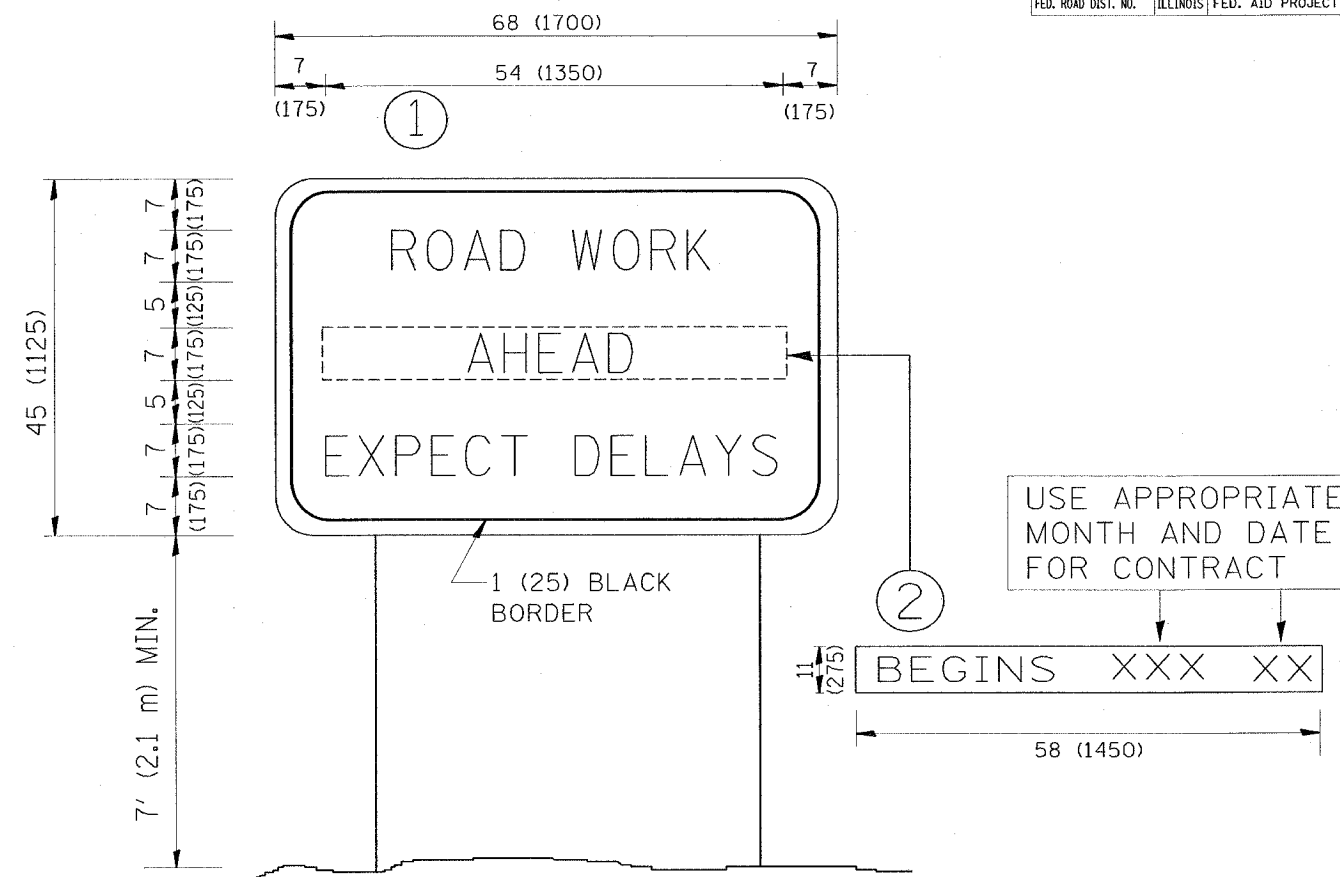

**NOTES:**

1. USE BLACK LETTERING ON ORANGE BACKGROUND.
2. ERECT SIGNS IN ADVANCE OF THE LOCATION FOR THE "ROAD CONSTRUCTION AHEAD" SIGN AT LOCATIONS AS DIRECTED BY THE ENGINEER.
3. ERECT SIGN ① WITH INSTALLED PANEL ② ONE WEEK PRIOR TO THE START OF CONSTRUCTION.
4. REMOVE PANEL ② SOON AFTER THE START OF CONSTRUCTION.
5. SEE SPECIAL PROVISION FOR "TEMPORARY INFORMATION SIGNING" FOR ADDITIONAL INFORMATION.
6. ONE SIGN ASSEMBLY EQUALS 25.70 SQ. FT. (2.3 SQ. M.)
7. SHALL BE PAID FOR AS TEMPORARY INFORMATION SIGNING.

ALL DIMENSIONS ARE IN INCHES (MILLIMETERS) UNLESS OTHERWISE SHOWN.

REVISIONS	
NAME	DATE
R. MIRS	9-15-97
R. MIRS	12-11-97
T. RAMMACHER	2-2-99
C. JUCIUS	1-31-07

ILLINOIS DEPARTMENT OF TRANSPORTATION  
**ARTERIAL ROAD  
INFORMATION SIGN**

SCALE: NONE

DRAWN BY DESIGN  
CHECKED BY

TC22

PLOT DATE = 3/28/2007  
FILE NAME = s:\dist\st\1022.dgn  
PLOT SCALE = 50.0000' / IN.  
USER NAME = abreuah



### LOOP DETECTOR NOTES

1. EACH PAIR OF LOOP WIRES SHALL BE PLACED IN A SEPARATE UNIT DUCT FROM THE EDGE OF PAVEMENT TO THE HANDHOLE. SPACING BETWEEN THE HOLES DRILLED IN THE PAVEMENT SHALL NOT BE LESS THAN 6" (150 mm). UNIT DUCT SHALL BE INCLUDED IN THE COST OF THE LOOP WIRE.
2. THE NUMBER OF LOOP TURNS SHALL BE AS RECOMMENDED BY THE AMPLIFIER MANUFACTURER. ALL ADJACENT SIDES OF THE LOOPS SHALL BE INSTALLED IN SUCH A WAY THAT THE CURRENT FLOW IS IN THE SAME DIRECTION TO REINFORCE ITS MAGNETIC FIELDS FOR SMALL VEHICLE DETECTION.
3. EACH LOOP LEAD-IN SHALL BE IDENTIFIED AND PERMANENTLY TAGGED IN THE HANDHOLE. EACH LEAD-IN CABLE TAG SHALL INDICATE THE LOCATION OF THE LOOP, LOOP ROTATION (CLOCKWISE/COUNTERCLOCKWISE), LOOP LEAD-IN DIRECTION (IN OR OUT), LOOP CABLE NUMBER AND LOCATION IN CABINET, AND NUMBER OF TURNS IN THE DETECTOR LOOPS IN WATER PROOF INK AS INDICATED ON THE DISTRICT 1 STANDARD TRAFFIC SIGNAL DESIGN DETAIL. THE CONTRACTOR SHALL MARK LOOP LOCATIONS ON RECORD DRAWINGS AND PRESENT TO THE ENGINEER AFTER FINAL INSPECTION. LOOPS SHALL BE MARKED BY LANE AND LOOP NUMBER. SEE DETAIL BELOW.
4. ALL LOOP CABLE SHALL BE FASTENED WITH PLASTIC TIE WRAP TO THE HANDHOLE HOOKS.
5. IN ASPHALT PAVEMENT, LOOPS SHOULD BE PLACED IN THE BINDER AND DIVEHOLES MARKED AT THE CURB WITH A SAW-CUT. THE SAW-CUT SHALL BE CUT IN ACCORDANCE WITH LOCAL AND E.P.A. DUST CONTROL REQUIREMENTS. DETECTOR LOOP(S) SHALL NOT BE INSTALLED IN WET CONDITIONS AND THE SAW-CUTS MUST BE FREE OF DEBRIS AND RESIDUE SUCH AS DUST AND WATER WHICH IS TO BE ACHIEVED BY THE USE OF COMPRESSED AIR, WIRE BRUSHING AND HEAT DRYING ACCORDING TO SEALANT MANUFACTURER REQUIREMENTS. THE DETECTOR WIRE SHALL BE HELD IN PLACE BY THE USE OF FORM WEDGES. WEDGES SHALL BE SPACED NO MORE THAN 18" (450 mm) APART.
6. LOOP SPLICES SHALL BE SOLDERED USING A SOLDERING IRON. BLOW TORCHES OR OTHER DEVICES WHICH OXIDIZE COPPER CABLE SHALL NOT BE ALLOWED FOR SOLDERING OPERATIONS. SEE DETAIL BELOW RIGHT.
7. PREFORMED DETECTOR LOOPS SHALL BE USED, AS SHOWN ON THE PLANS, WHERE NEW CONCRETE PAVEMENT IS PROPOSED. THE INSTALLATION OF PREFORMED LOOPS SHALL BE IN ACCORDANCE WITH THE DISTRICT 1 SPECIFICATIONS OR AS DIRECTED BY THE ENGINEER.

#### LOOP LEAD-IN CABLE TAG

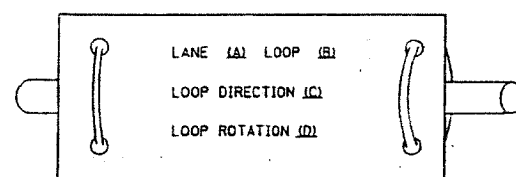

- LANE 1 IS THE LANE CLOSEST TO THE CENTERLINE OF THE ROADWAY
- LOOP #1 IS THE LOOP IN THE LANE CLOSEST TO THE INTERSECTION.
- LABEL LOOP CABLE "IN" OR LOOP CABLE "OUT".
- LABEL LOOP CABLE CLOCKWISE OR LOOP CABLE COUNTERCLOCKWISE.

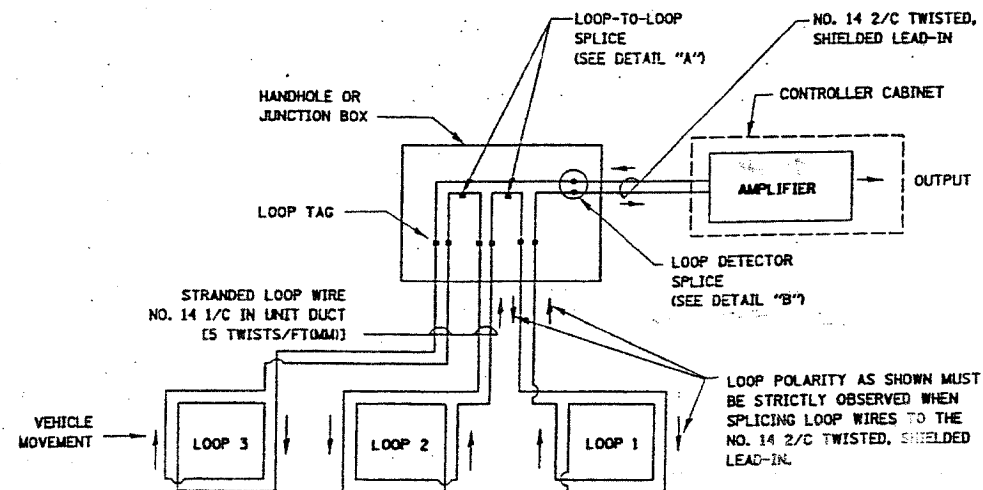

#### DETECTOR LOOP WIRING SCHEMATIC

- LOOPS SHALL BE SPLICED IN SERIES.
- SAW-CUTS SHALL BE A MINIMUM WIDTH OF 5/16" (8 mm).
- SAW-CUT DEPTHS SHALL BE 3" (75 mm). IF IN CONCRETE, THE SAW-CUT DEPTH SHALL BE TO THE TOP OF THE REINFORCEMENT.
- LOOP CORNERS SHALL BE DRILLED WITH A 2" (50 mm) DIAMETER CORE.

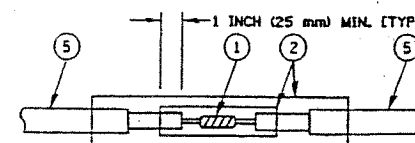

DETAIL "A"  
LOOP-TO-LOOP SPLICE

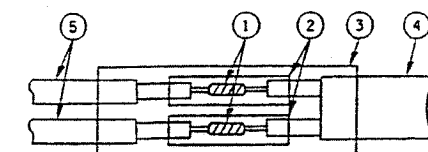

DETAIL "B"  
LOOP-TO-CONTROLLER SPLICE

#### LOOP DETECTOR SPLICE

- 1 WESTERN UNION SPLICE SOLDERED WITH ROSIN CORE FLUX. ALL EXPOSED SURFACES OF THE SOLDER SHALL BE SMOOTH.
- 2 WCSM 30/100 HEAT SHRINK TUBE, MINIMUM LENGTH 3" (75 mm), UNDERWATER GRADE.
- 3 WCS 200/750 HEAT SHRINK TUBE, MINIMUM LENGTH 6" (150 mm), UNDERWATER GRADE.
- 4 NO. 14 2/C TWISTED, SHIELDED CABLE.
- 5 LOOP CONDUCTOR WITH FLEXIBLE PLASTIC TUBE.

REVISIONS	
NAME	DATE

ILLINOIS DEPARTMENT OF TRANSPORTATION  
DISTRICT ONE  
STANDARD TRAFFIC SIGNAL  
DESIGN DETAILS

SCALE: VERT. NONE  
HORIZ. NONE  
DATE 1-01-02

DRAWN BY: RWP  
DESIGNED BY: DAD  
CHECKED BY: JAZ  
SHEET 31 OF 31

ARTERIAL-VOLUME DENSITY ("FAR BACK" DETECTION)  
CROSS STREET-VOLUME DENSITY ("FAR BACK DETECTION")

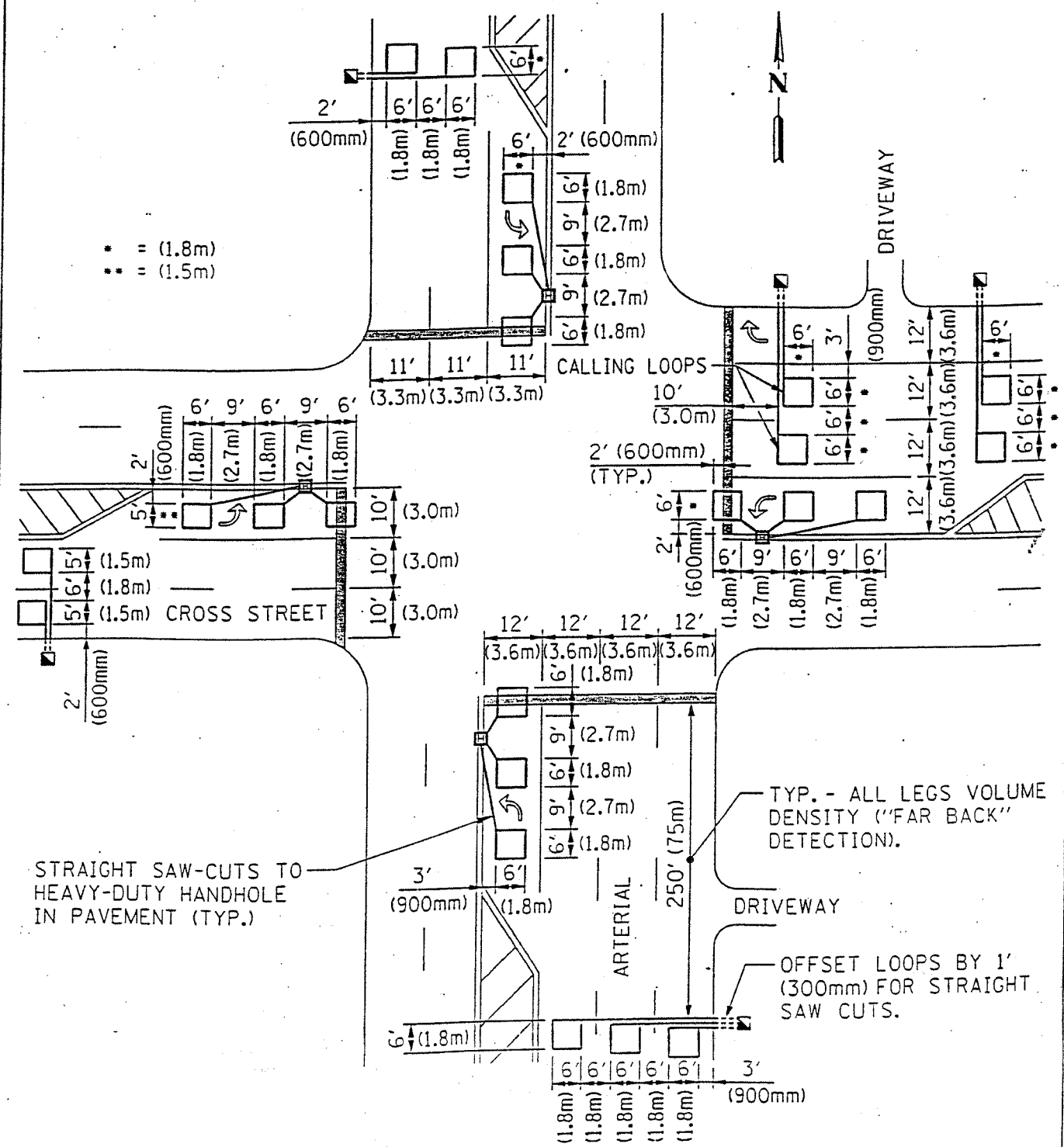

LOOPS ARE SAW-CUT TO THE EDGE OF PAVEMENT. 1" (25mm) UNIT DUCT IS RUN BETWEEN EDGE OF PAVEMENT AND HANDHOLE. (TYP. FOR LOOPS THAT TERMINATE IN HANDHOLES OUTSIDE PAVEMENT).

N.T.S.

ARTERIAL-VOLUME DENSITY ("FAR BACK" DETECTION)  
CROSS STREET-NON VOLUME DENSITY ("UPTIGHT" PRESENCE DETECTION)

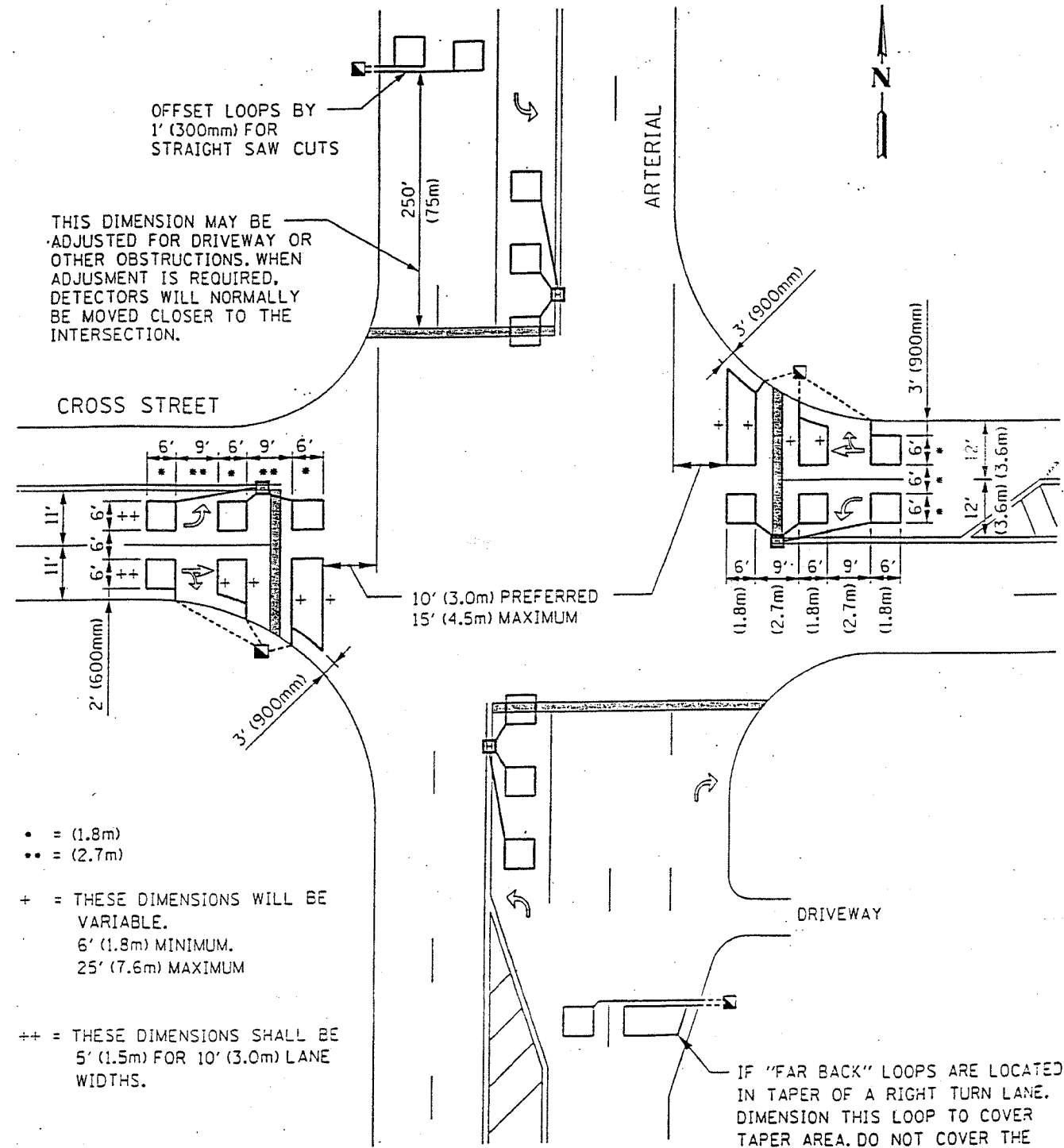

N.T.S.