

F.A.P. NO.	SECTION	COUNTY	TOTAL SHEETS	SHEET NO.
303	131B(1&2)BR	McHENRY	107	57
STA.		TO STA.		
FED. ROAD DIST. NO.		ILLINOIS	FED. AID PROJECT	

CONTRACT NO. 60B83

**NOTES**

Bar splicer assemblies shall be of an approved type and shall develop in tension at least 125 percent of the yield strength of the lapped reinforcement bars.  
 Splicer rods shall be of minimum 60 ksi yield strength, threaded or coiled full length.  
 All reinforcement bars shall be lapped and tied to the splicer rods or dowel bars.  
 Bar splicer assemblies shall be epoxy coated according to the requirements for reinforcement bars.  
 Other systems of similar design may be submitted to the Engineer for approval. Approval shall be based on certified test results from an approved testing laboratory that the proposed bar splicer assembly satisfies the following requirements:

- ① Minimum Capacity (Tension in kips) =  $1.25 \times f_y \times A_t$
  - ② Minimum \*Pull-out Strength (Tension in kips) =  $0.66 \times f_y \times A_t$
- Where  $f_y$  = Yield strength of lapped reinforcement bars in ksi.  
 $A_t$  = Tensile stress area of lapped reinforcement bars.  
 \* = 28 day concrete

BAR SPLICER ASSEMBLIES			
Bar Size to be Spliced	Splicer Rod or Dowel Bar Length	Strength Requirements	
		Min. Capacity kips - tension	Min. Pull-Out Strength kips - tension
#4	1'-8"	14.7	7.9
#5	2'-0"	23.0	12.3
#6	2'-7"	33.1	17.4
#7	3'-5"	45.1	23.8
#8	4'-6"	58.9	31.3
#9	5'-9"	75.0	39.6
#10	7'-3"	95.0	50.3
#11	9'-0"	117.4	61.8

The diameter of this part is the same as the diameter of the bar spliced.

The diameter of this part is equal or larger than the diameter of bar spliced.

**ROLLED THREAD DOWEL BAR**



**\*\* ONE PIECE**

Wire Connector



**WELDED SECTIONS**

**BAR SPLICER ASSEMBLY ALTERNATIVES**

\*\* Heavy Hex Nuts conforming to ASTM A 563, Grade C, D or DH may be used.

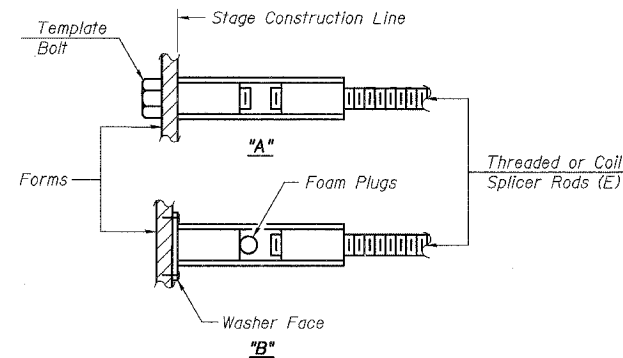

**INSTALLATION AND SETTING METHODS**

"A" : Set bar splicer assembly by means of a template bolt.  
 "B" : Set bar splicer assembly by nailing to wood forms or cementing to steel forms.  
 (E) : Indicates epoxy coating.

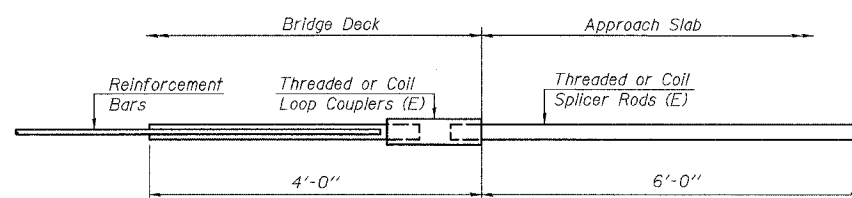

**FOR INTEGRAL OR SEMI-INTEGRAL ABUTMENTS**

Bar Splicer for #5 bar
Min. Capacity = 23.0 kips - tension
Min. Pull-out Strength = 12.3 kips - tension
No. Required = 82

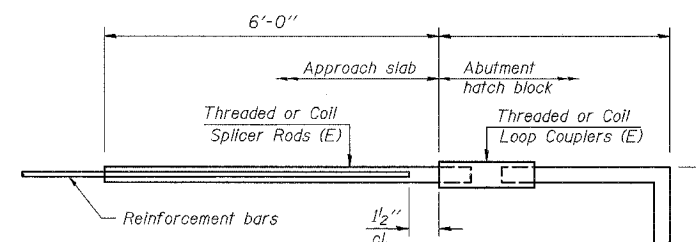

**FOR STUB ABUTMENTS**

Bar Splicer for #5 bar
Min. Capacity = 23.0 kips - tension
Min. Pull-out Strength = 12.3 kips - tension
No. Required =

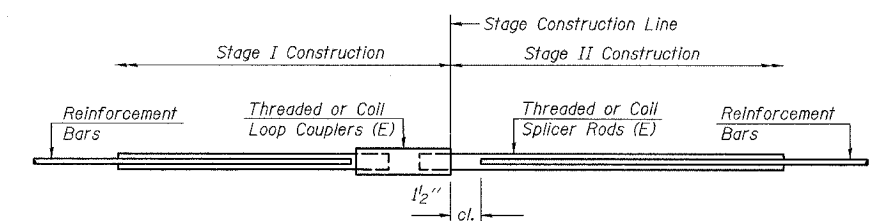

**STANDARD**

Bar Size	No. Assemblies Required	Location
#5	325	Deck
#6	16	Diaphragm
#6	20	Abutments
#6	18	Pier
#7	10	
Total	389	

REVISIONS	
NAME	DATE

ILLINOIS DEPARTMENT OF TRANSPORTATION  
**BAR SPLICER ASSEMBLY DETAILS**  
 IL. RTE. 173  
 OVER  
 PISCASAW CREEK OVERFLOW  
 F.A.P. RTE. 303 SECTION: 131B(1&2)BR  
 McHENRY COUNTY STATION 90+20.80  
 STRUCTURE NO. 056-0089  
 SCALE: DRAWN BY: D.L./F.M.  
 DATE: APRIL 13, 2007 CHECKED BY: B.N.S./J.C.N.  
**CHRISTIAN-ROGE & ASSOC., INC.**  
 CHICAGO ILLINOIS

...:SDP 001007.dwg 4/12/07 3:36:15 PM