

F.A.P. RTE.	SECTION	COUNTY	TOTAL SHEETS	SHEET NO.
311	8 Y-RS-3	COOK	28	9
STA.		TO STA.		
FED. ROAD DIST. NO. 1		ILLINOIS FED. AID PROJECT		
CONTRACT NO. 60C56				

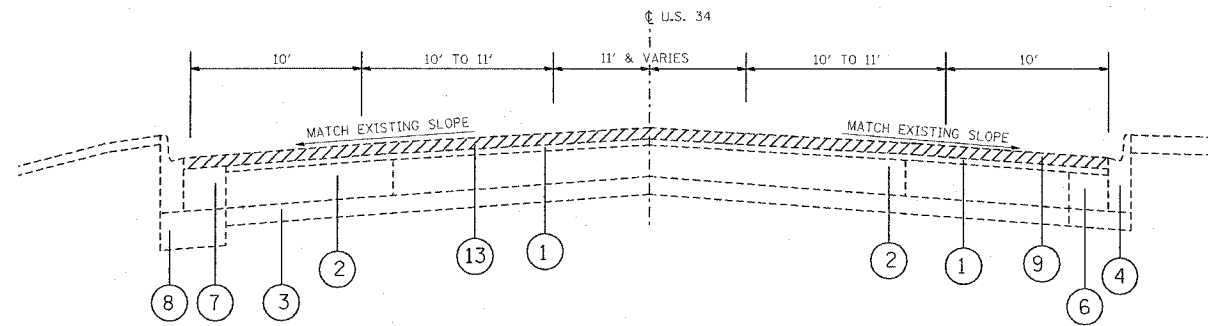

PROPOSED TYPICAL SECTION
U.S. 34 (OGDEN AVE).

STATION
56+76 TO 61+83

LEGEND

- ① EXISTING HOT-MIX ASPHALT SURFACE COURSE, 4"(±)
- ② EXISTING PCC BASE COURSE, 9"(±)
- ③ EXISTING SUB-BASE GRANULAR MATERIAL
- ④ EXISTING COMBINATION CONC. CURB & GUTTER TYPE B6.12
- ⑤ EXISTING HMA SHOULDER
- ⑥ EXISTING P.C. CONC BASE COURSE
- ⑦ EXISTING HMA BINDER COURSE
- ⑧ EXISTING AGGREGATE SUBGRADE
- ⑨ HOT-MIX ASPHALT SURFACE REMOVAL - 2 1/2 "
- ⑩ PROPOSED POLYMERIZED HOT-MIX ASPHALT SURFACE COURSE, MIX "F", N90, 1 3/4 "
- ⑪ PROPOSED POLYMERIZED LEVELING BINDER (MM), IL-4.75, N50, 3/4 "

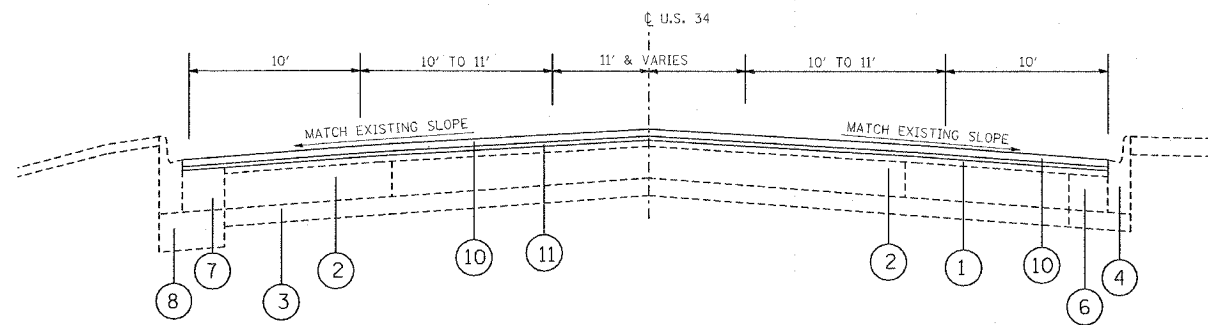

PROPOSED TYPICAL SECTION
U.S. 34 (OGDEN AVE).

STATION
56+76 TO 61+83

PLOT DATE = 4/11/2007
 FILE NAME = c:\pcc\lscs\124207\design\as.dgn
 PLOT SCALE = 50.0000' / IN.
 USER NAME = guresthu

REVISIONS	
NAME	DATE

ILLINOIS DEPARTMENT OF TRANSPORTATION

U.S. 34
EXISTING AND PROPOSED
TYPICAL SECTIONS

SCALE: VERT.
HORIZ.
DATE

DRAWN BY
CHECKED BY