

STATE OF ILLINOIS  
DEPARTMENT OF TRANSPORTATION

ROUTE NO.	SECTION	COUNTY	SHEET NO.	SHEET NO.
F.A.P. 693	(119B-31)	TAZEWELL	33	15
SHEET NO. 6 14 SHEETS				
Contract #68415				

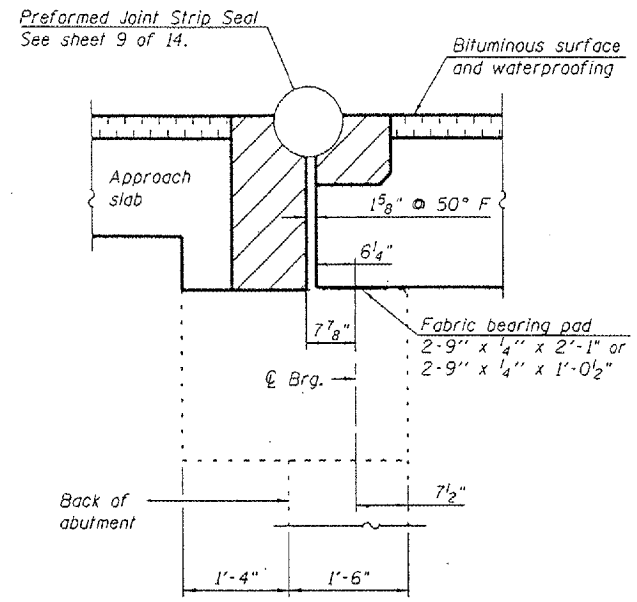

SECTION THRU WEST ABUTMENT

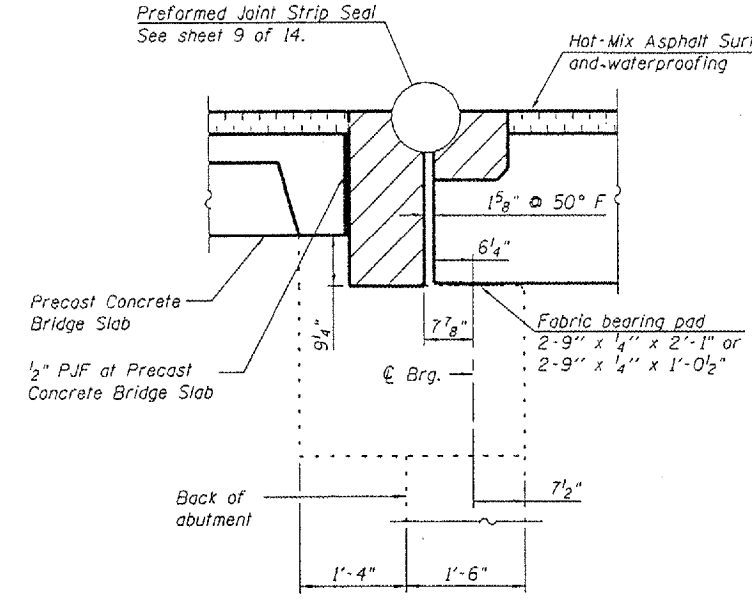

SECTION THRU WEST ABUTMENT  
(At outside precast unit)

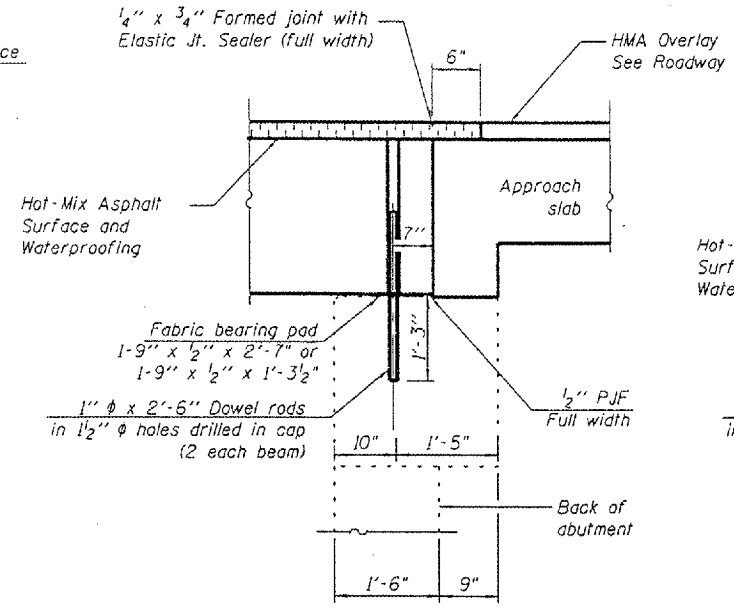

SECTION THRU EAST ABUTMENT

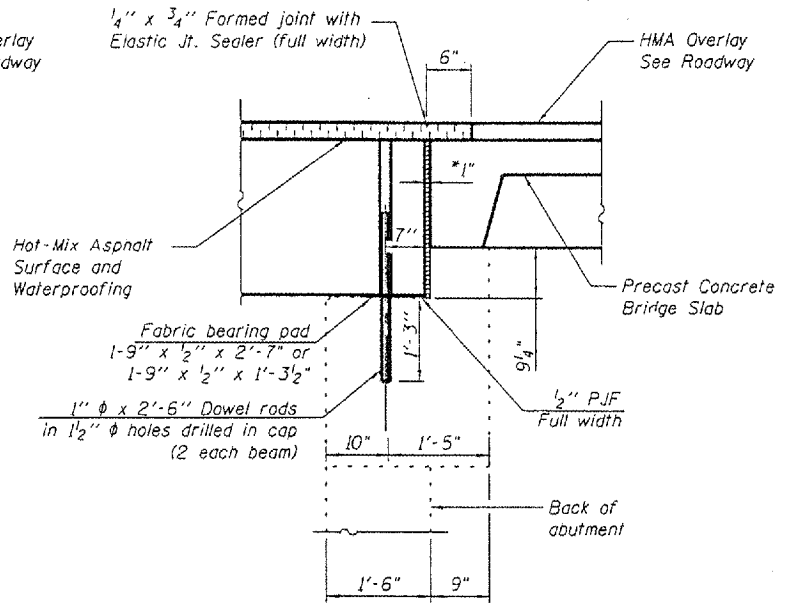

SECTION THRU EAST ABUTMENT  
(At outside precast unit)

\* 1" joint shall be filled with non-shrink grout.  
1" dimension may vary to accommodate tolerance in beam lengths.

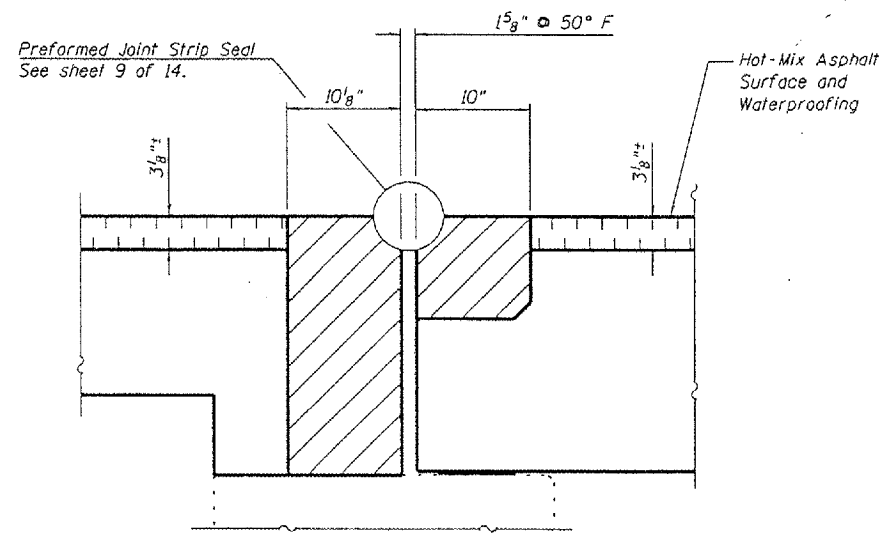

Bituminous Surface Detail  
(At West Abutment)

Notes:  
Ends of beams shall be aligned at the expansion joint. Any linear variation in the beam lengths shall be placed at the fixed joint.  
After beams have been erected, temporary retainers shall be installed, holes shall be drilled into substructure and anchor dowels placed. Dowel holes shall be filled with non-shrink grout to top of beam and allowed to cure min. 24 hrs. prior to grouting the shear keys.  
Hatched area to be poured after beams are in place and keyways grouted and cured. Quantity included with Concrete Structures on Sheet 11 of 14.  
Dowel rods drilled in cap are included in the cost of Precast Prestressed Concrete Deck Beams (27" Depth).  
All horizontal dimensions are at right angles to beam ends.  
See sheet 4 of 14 for bearing pad details.

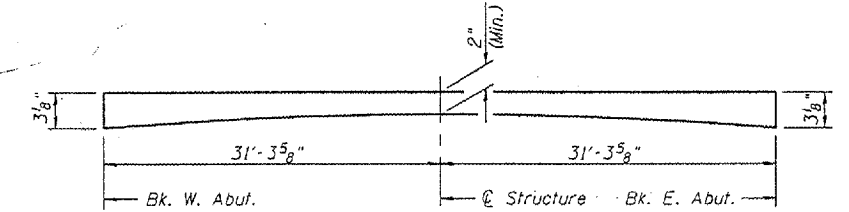

HOT-MIX ASPHALT WEARING SURFACE PROFILE

DESIGNED BWP	THOUVENOT, WADE & MOERCHEN, INC. ENGINEERS & SURVEYORS - PLANNERS  CORPORATE OFFICE 1340 OLD COLLINGSVILLE RD. SPRINGFIELD, ILLINOIS 62776 TEL: (618) 624-1488 FAX: (618) 624-0688 E-MAIL: COW@TWM-INC.COM
CHECKED ALN	
DRAWN BWP	
CHECKED KPC	

SUPERSTRUCTURE DETAILS  
ILLINOIS ROUTE 9 OVER  
PRAIRIE CREEK  
F.A.P. ROUTE 693 SECTION (119B-31)  
TAZEWELL COUNTY  
SN 090-0061