

F.A.P. RTE.	SECTION	COUNTY	TOTAL SHEETS	SHEET NO.
317	(9,10,11) RS-3	SCHUYLER	23	10
STA.		TO STA.		
FED. ROAD DIST. NO.		ILLINOIS	FED. AID PROJECT	
CONTRACT 72838				

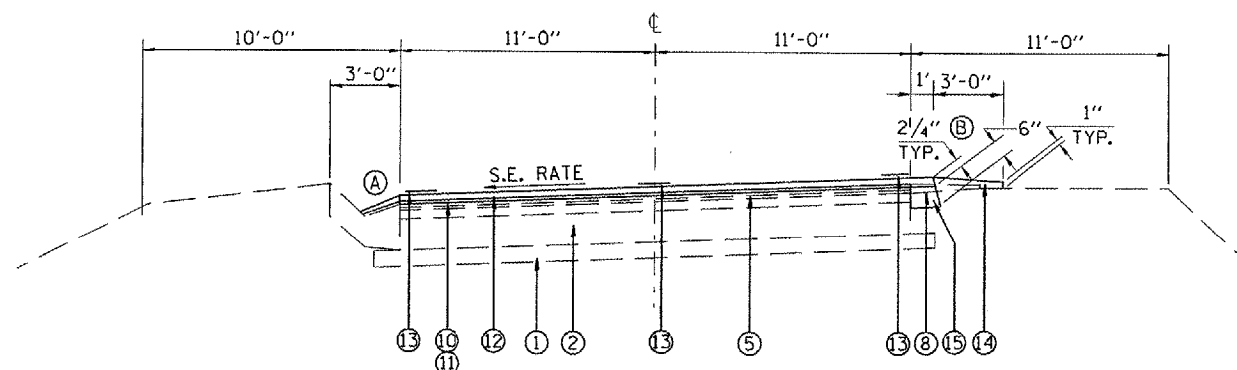

STA. 488+10 TO STA. 506+00

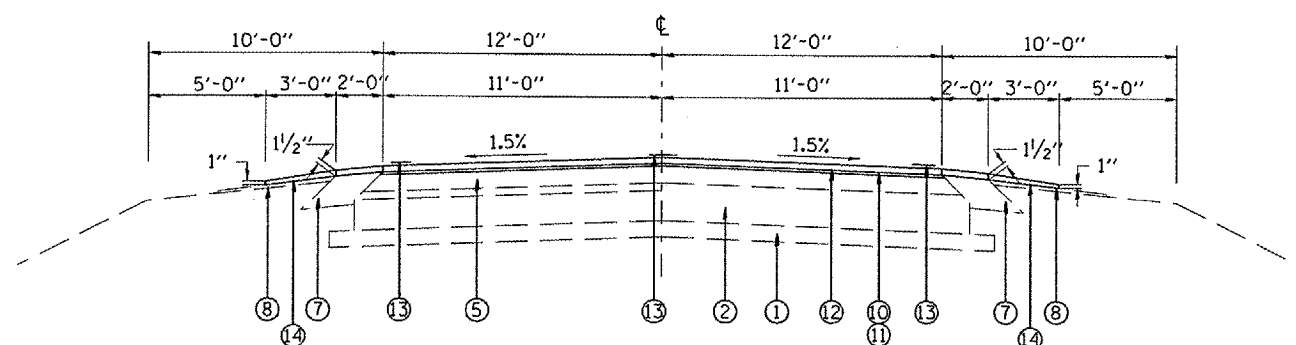
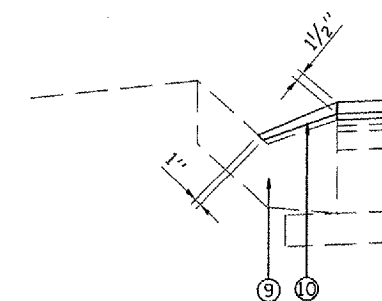

STA. 577+00 to 581+60
STA. 345+50 to 357+90.89

- ① EXISTING AGGREGATE SUB-BASE 4"
- ② EXISTING P.C.C. BASE COURSE 8"
- ③ EXISTING P.C.C PAVEMENT
- ④ EXISTING P.C.C. BASE COURSE WIDENING 9"
- ⑤ EXISTING HOT-MIX ASPHALT PAVEMENT 3" ±
- ⑥ EXISTING STRIP REFLECTIVE CRACK CONTROL SPECIAL
- ⑦ EXISTING BITUMINOUS SHOULDER 8"
- ⑧ EXISTING AGGREGATE SHOULDER TYPE A
- ⑨ EXISTING CONCRETE GUTTER
- ⑩ PROPOSED HOT-MIX ASPHALT SURFACE REMOVAL - VARIABLE DEPTH
- ⑪ PROPOSED HOT-MIX ASPHALT LEVELING BINDER, 3/4"
- ⑫ PROPOSED HOT-MIX ASPHALT SURFACE COURSE, 1/2"
- ⑬ PROPOSED PAVEMENT MARKING
- ⑭ PROPOSED AGGREGATE SHOULDER
- ⑮ PROPOSED HMA SHOULDER -6"

NOTES FOR SHOULDER SLOPES:

- (A) LOW SIDE OF SE: THE SHOULDER SLOPE SHALL BE THE SAME AS SE RATE BUT NOT LESS THAN 4.0%.
- (B) HIGH SIDE OF SE: WHEN THE SE RATE OF THE PAVEMENT IS BETWEEN 0.0% AND 4.0% THE SHOULDER SHALL BE 4.0%. WHEN THE RATE OF THE PAVEMENT EXCEEDS 4.0% THE SHOULDER SHALL BE SLOPED SO THAT THE ALGEBRAIC DIFFERENCE BETWEEN PAVEMENT AND SHOULDER SLOPES WILL NOT BE GREATER THAN 8.0%.

REVISIONS	
NAME	DATE

ILLINOIS DEPARTMENT OF TRANSPORTATION

TYPICAL SECTIONS
F. A. P. ROUTE 317 (US 24)
SECTION (9, 10, 11) RS-3
SCHUYLER COUNTY

SCALE: NONE
DATE: NOV, 2003

DRAWN BY AGG
CHECKED BY MJS