

F.A.P. RTE.	SECTION	COUNTY	TOTAL SHEETS	SHEET NO.
317 (9,10,11)	RS-3	SCHUYLER	23	12
STA.	TO STA.			
FED. ROAD DIST. NO.	ILLINOIS FED. AID PROJECT			
CONTRACT 72838				

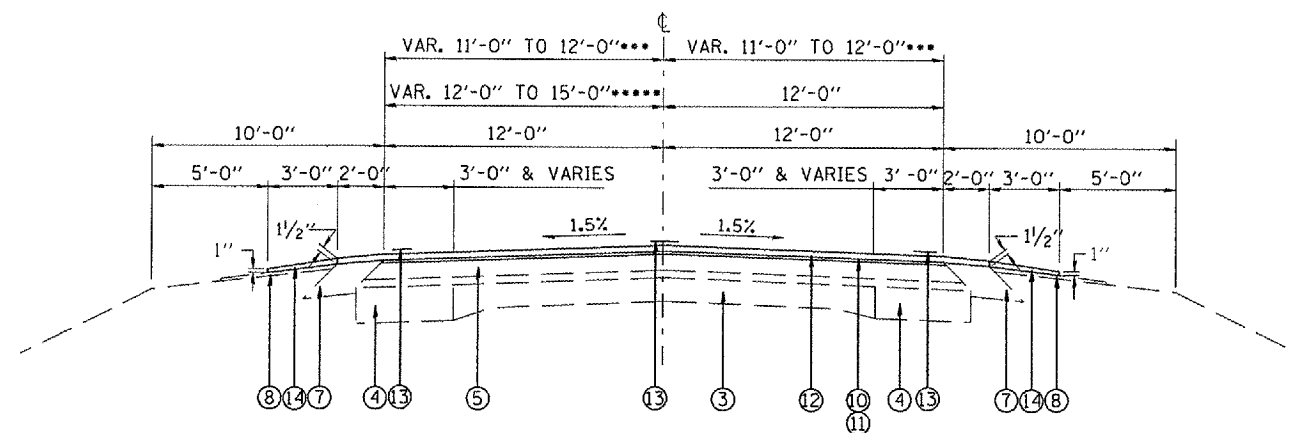

STA. 581+60 TO 584+50***
 STA. 584+50 TO 588+44.00 (BK)****
 STA. 150+38.00 AH TO 192+82.87
 STA. 235+49.57 TO 248+83.42
 STA. 259+16.76 TO 262+82.29
 STA. 275+24.53 TO 284+74.95
 STA. 292+07.11 TO 345+50

NOTES:

- *** PAVEMENT WIDTH OF MAINLINE TRANSITIONS FROM 22'-0" @ STA. 581+60 TO 24'-0" @ STA. 584+50
- **** STA. EQ 588+44.00 (BK) = 150+38.00 (AH)

- ① EXISTING AGGREGATE SUB-BASE 4"
- ② EXISTING P.C.C. BASE COURSE 8"
- ③ EXISTING P.C.C. PAVEMENT
- ④ EXISTING P.C.C. BASE COURSE WIDENING 9"
- ⑤ EXISTING HOT-MIX ASPHALT PAVEMENT 3" ±
- ⑥ EXISTING STRIP REFLECTIVE CRACK CONTROL SPECIAL
- ⑦ EXISTING BITUMINOUS SHOULDER 8"
- ⑧ EXISTING AGGREGATE SHOULDER TYPE A
- ⑨ EXISTING CONCRETE GUTTER
- ⑩ PROPOSED HOT-MIX ASPHALT SURFACE REMOVAL - VARIABLE DEPTH
- ⑪ PROPOSED HOT-MIX ASPHALT LEVELING BINDER, 3/4"
- ⑫ PROPOSED HOT-MIX ASPHALT SURFACE COURSE, 1 1/2"
- ⑬ PROPOSED PAVEMENT MARKING
- ⑭ PROPOSED AGGREGATE SHOULDER

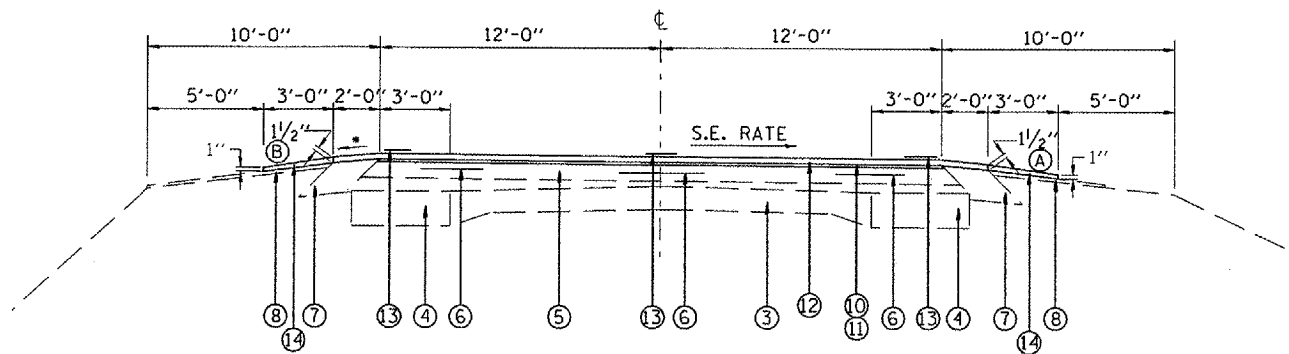

STA. 248+83.42 TO 259+16.76
 STA. 262+82.29 TO 275+24.53

NOTES FOR SHOULDER SLOPES:

- Ⓐ LOW SIDE OF SE: THE SHOULDER SLOPE SHALL BE THE SAME AS SE RATE BUT NOT LESS THAN 4.0%.
- Ⓑ HIGH SIDE OF SE: WHEN THE SE RATE OF THE PAVEMENT IS BETWEEN 0.0% AND 4.0% THE SHOULDER SHALL BE 4.0%. WHEN THE RATE OF THE PAVEMENT EXCEEDS 4.0% THE SHOULDER SHALL BE SLOPED SO THAT THE ALGEBRAIC DIFFERENCE BETWEEN PAVEMENT AND SHOULDER SLOPES WILL NOT BE GREATER THAN 8.0%.

REVISIONS		ILLINOIS DEPARTMENT OF TRANSPORTATION
NAME	DATE	
		TYPICAL SECTIONS F. A. P. ROUTE 317 (US 24) SECTION (9, 10, 11) RS-3 SCHUYLER COUNTY SCALE: NONE DATE: NOV, 2003
DRAWN BY AGG		CHECKED BY MJS
DATE: NOV, 2003		