

F.A.P. RTE.	SECTION	COUNTY	TOTAL SHEETS	SHEET NO.
310	87 RS-3	SCHUYLER	26	9
STA.		TO STA.		
FED. ROAD DIST. NO.	ILLINOIS	FED. AID PROJECT		
CONTRACT 72839				

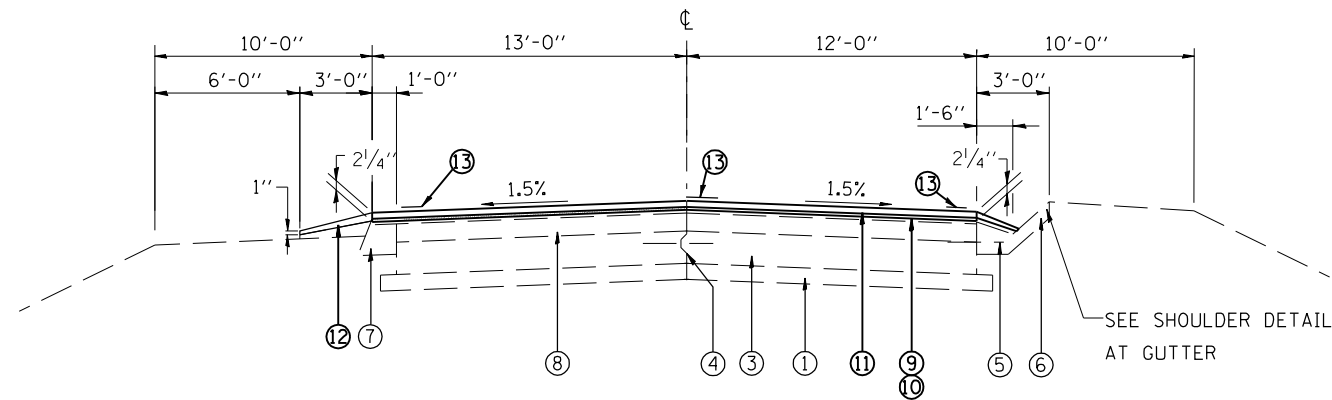

206+55 TO 225+00  
229+25 TO 236+00

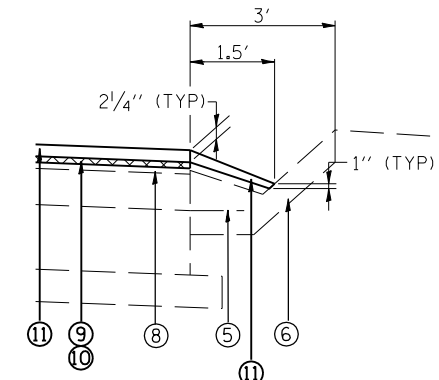

**LEGEND**

- ① EXISTING SUB-BASE GRANULAR MATERIAL 4"
- ② EXISTING SUB-BASE GRANULAR MATERIAL 14"
- ③ EXISTING P.C.C. BASE COURSE 8"
- ④ EXISTING LONGITUDINAL METAL JOINT WITH 1/2"Ø DEFORMED BAR
- ⑤ EXISTING #4 TIE BAR
- ⑥ EXISTING CONCRETE GUTTER
- ⑦ EXISTING BITUMINOUS SHOULDER
- ⑧ EXISTING BITUMINOUS SURFACE 6"±
- ⑨ PROPOSED HMA SURFACE REMOVAL -3/4"
- ⑩ PROPOSED HMA BINDER, 2 1/4"
- ⑪ PROPOSED HMA CONCRETE SURFACE COURSE, 1 1/2"
- ⑫ PROPOSED AGGREGATE SHOULDER, TYPE B
- ⑬ PROPOSED PAVEMENT MARKING, LINE 5"

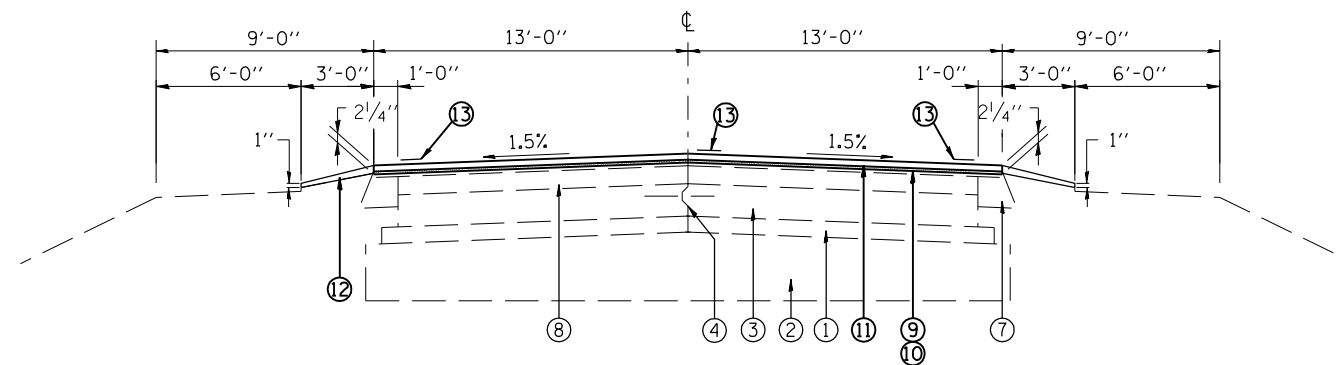

310+50 TO 312+50  
344+00 TO 346+50

REVISIONS	
NAME	DATE

ILLINOIS DEPARTMENT OF TRANSPORTATION

**TYPICAL SECTIONS**  
F. A. P. ROUTE 310 (US 67)  
SECTION 87 RS-3  
SCHUYLER COUNTY

SCALE: NONE  
DATE: NOV, 2003

DRAWN BY AGG  
CHECKED BY MJS