

F.A.P. RTE.	SECTION	COUNTY	TOTAL SHEETS	SHEET NO.
666	SP-2, RS-4	SANGAMON	80	77
STA.		TO STA.		
FED. ROAD DIST. NO.		ILLINOIS FED. AID PROJECT		

LENGTH OF SLACK FOR LOOP LEAD-INS SHALL PROVIDE FOR MAKING THE SPLICE ON TOP OF THE HANDHOLE AND ONE COMPLETE LOOP OF THE INTERIOR OF THE HANDHOLE. THE SPLICE SHALL BE SUPPORTED BY A CABLE HOOK.

THE LOOP LEAD-IN CONDUIT HOLES SHALL BE PLACED AS CLOSE TO THE CURB AS POSSIBLE TO PERMIT SAW OVERLAP WITHOUT SCARRING FACE OF CURB. IN NON-CURB LOCATIONS THE DISTANCE SHALL NOT BE LESS THAN 6".

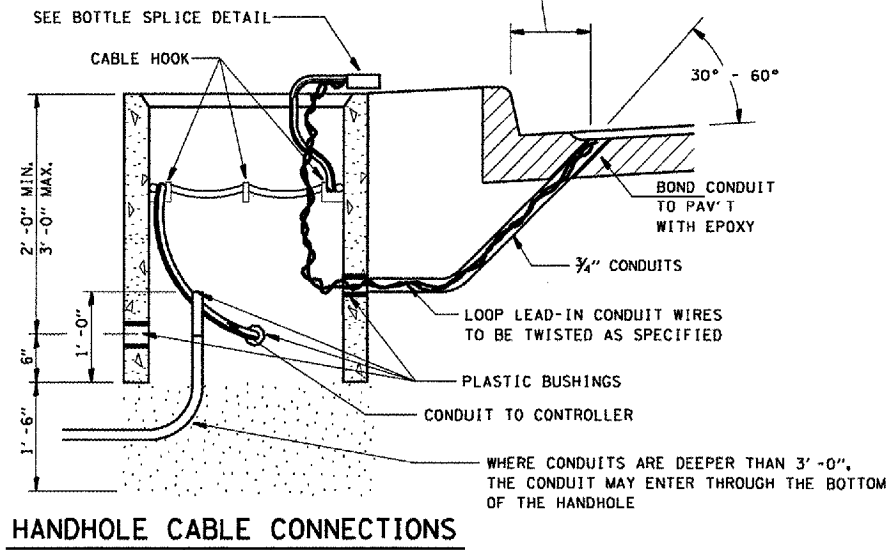

HANDHOLE CABLE CONNECTIONS

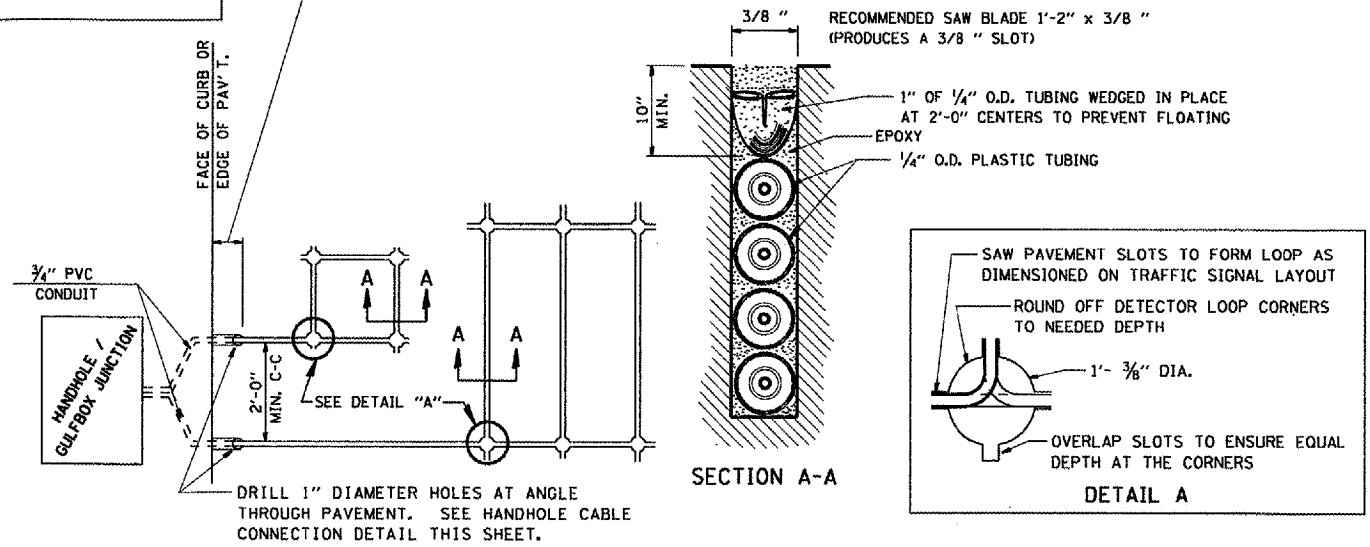

PAVEMENT SAWING DETAIL FOR TUBE ENCASED DETECTOR LOOP WIRE

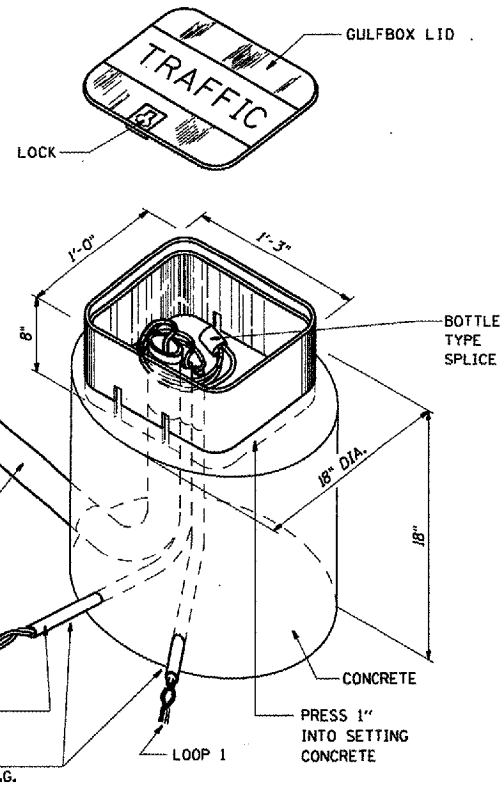

GULFBOX JUNCTION DETAIL

(SHOWING CONNECTION OF TUBE-ENCASED DETECTOR LOOP TO MULTI-PAIR LEAD-IN CABLE)

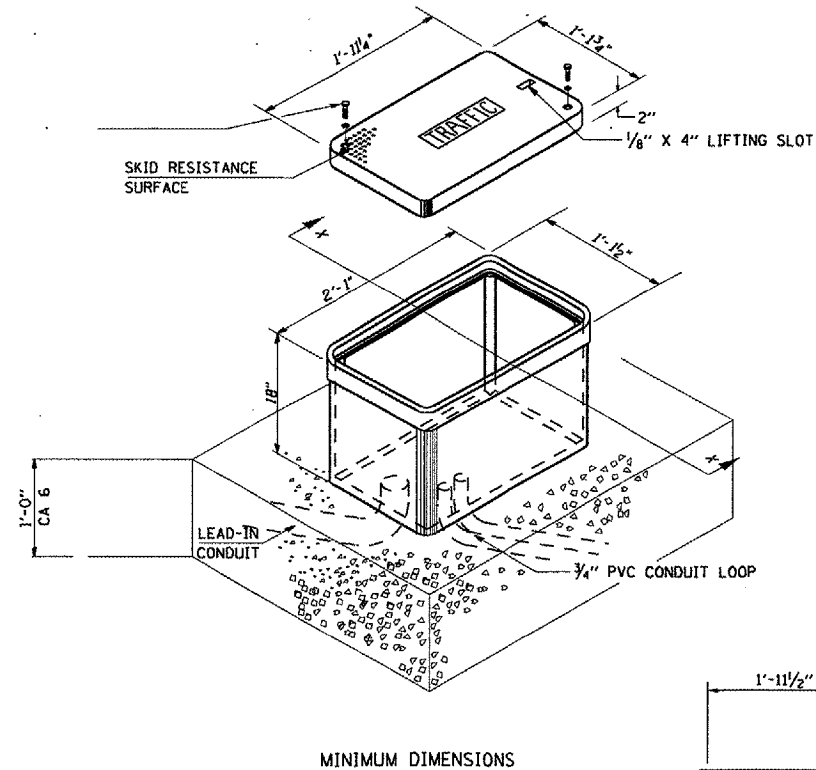

JUNCTION BOX (SPECIAL)

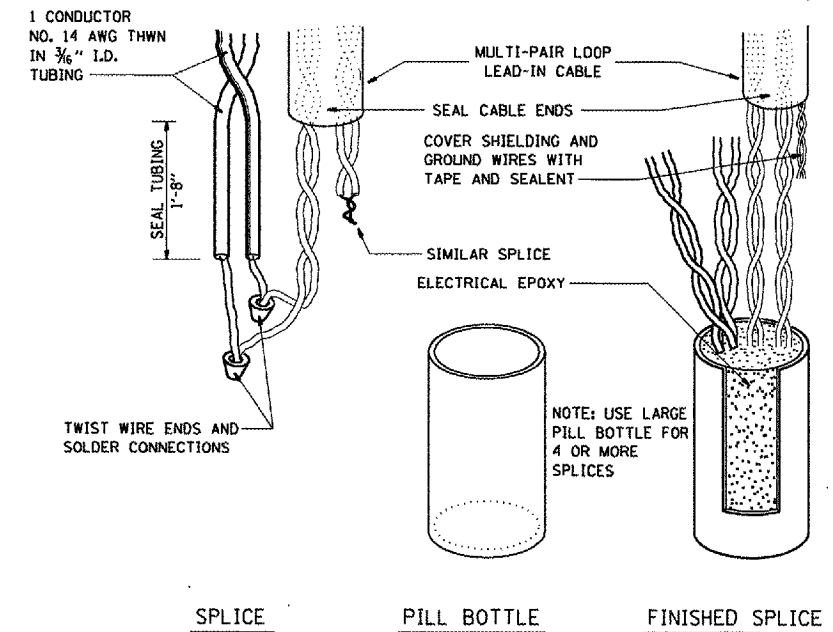
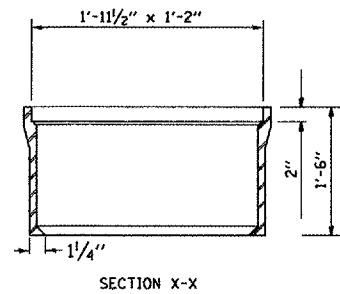

BOTTLE SPLICE DETAIL

REVISIONS	
NAME	DATE

ILLINOIS DEPARTMENT OF TRANSPORTATION

**TRAFFIC SIGNAL DETAILS**

FAP ROUTE 666 (I-55 BUS/9TH STREET)

DETECTOR LOOP DETAILS

SCALE: VERT. HORIZ.

DATE

DRAWN BY

CHECKED BY

PLOT DATE = 00/00/00  
 FILE NAME = 000000  
 PLOT SCALE = 000000  
 USER NAME = 000000