

STATE OF ILLINOIS
DEPARTMENT OF TRANSPORTATION

| ROUTE NO. | SECTION | QUANTITY | 15' SHEETS | SHEET NO. |
|------------|-------------|----------|------------|-----------|
| F.A.P. 328 | (BBR-1) B-1 | WAYNE | 68 | 21 |

SHEET NO. 3
13 SHEETS

Contract #74003

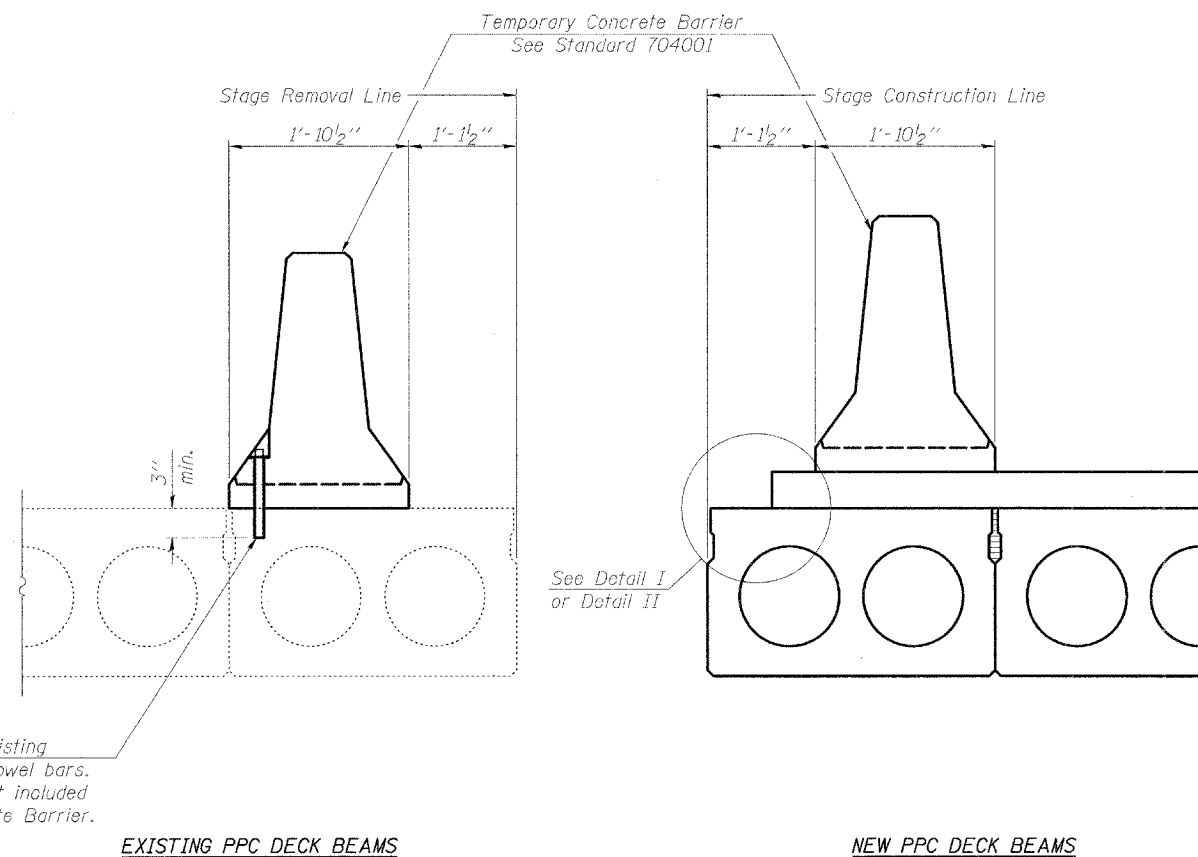

SECTION THRU PPC DECK BEAMS

Drill 1/4" ϕ Holes in existing beam for 1" ϕ x 11" dowel bars. Traffic side only. Cost included with Temporary Concrete Barrier.

- NOTES**
- Detail I - With Bar Splicer or Couplers:
Connect one (1) 1"x7"x10" steel \bar{L} to the couplers with 2-5/8" ϕ bolts screwed to coupler at approximate \bar{C} of each barrier panel.
- Detail II - With Extended Reinforcement Bars:
Connect one (1) 1"x7"x10" steel \bar{L} to the concrete wearing surface with 2-5/8" ϕ Expansion Anchors or cast in place inserts spaced between the reinforcement at approximate \bar{C} of each barrier panel.
- Cost of anchorage is included with Temporary Concrete Barrier. The 1" x 7" x 10" plate shall not be removed until stage II construction PPC deck beams and all reinforcement bars are in place and the concrete is ready to be placed.

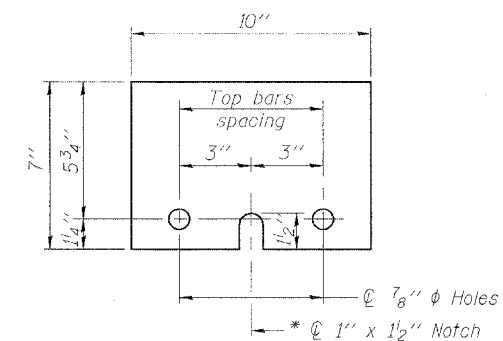

STEEL RETAINER \bar{L} 1" x 7" x 10"

* Required only with Detail II

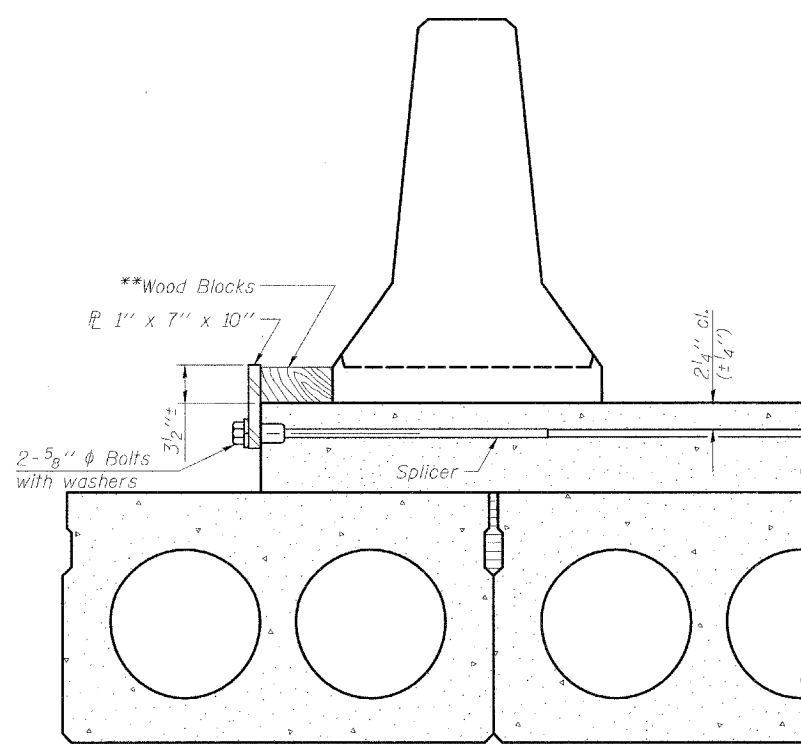

DETAIL I

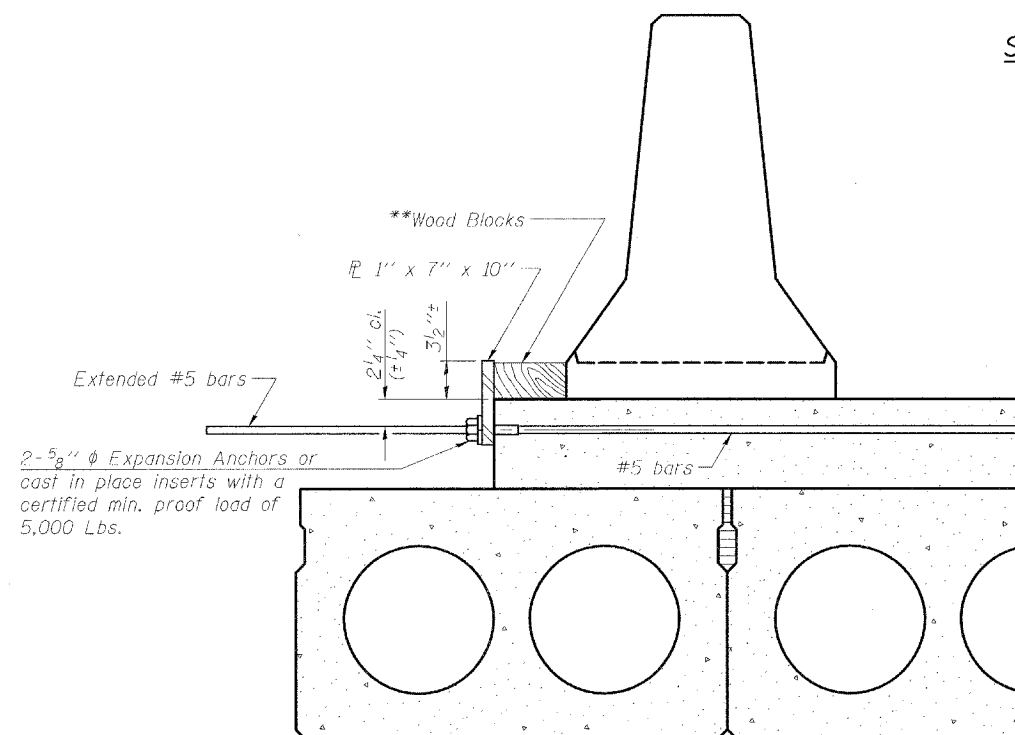

DETAIL II

TEMPORARY CONCRETE BARRIER
FOR STAGE CONSTRUCTION

F.A.P. ROUTE 328 - SECTION (BBR-1)B-1

WAYNE COUNTY

STATION 719+63.09

STRUCTURE NO. 096-0020

| | |
|----------|-----|
| DESIGNED | JJD |
| CHECKED | EML |
| DRAWN | JJD |
| CHECKED | EML |

** Wood blocks may be omitted when required to provide minimum stage traffic lane width. When the wood blocks are omitted, the concrete barrier shall be in direct contact with the steel retainer plate.

**HORNER &
SHIFRIN, INC.**
ENGINEERS