

STATE OF ILLINOIS
DEPARTMENT OF TRANSPORTATION

ROUTE NO.	SECTION	COUNTY	TOTAL SHEETS	SHEET NO.	SHEET NO. 11 13 SHEETS
F.A.P. 328	(8BR-1) B-1	WAYNE	68	29	
FED. ROAD DIST. NO. 7	ILLINOIS	FED. AID PROJECT-			

Contract #74003

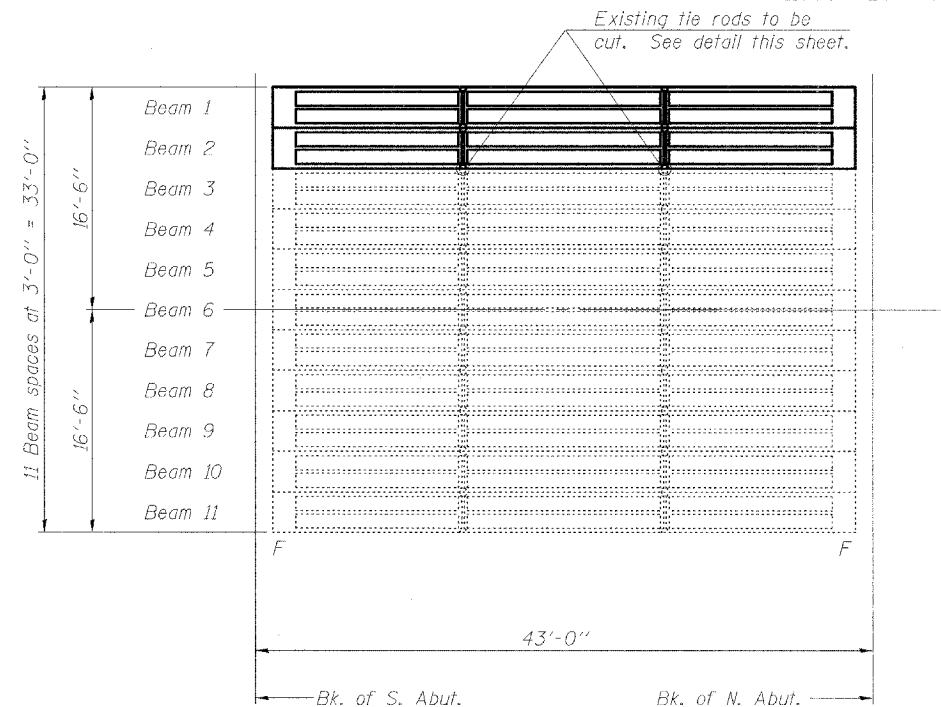

PLAN

GENERAL NOTES

The thickness of Bituminous overlay shall match the existing thickness and shall be adjusted for the new expected beam camber.
Plan dimensions and details relative to existing structure have been taken from existing plans and are subject to nominal construction variations. It shall be the Contractor's responsibility to verify such dimensions and details in the field and make necessary approved adjustments prior to construction or ordering of materials. Such variations shall not be cause for additional compensation for a change in the scope of the work, however, the Contractor will be paid for the quantity actually furnished at the unit price for the work.
The cut strands at each beam end shall be given two coats of zinc dust spray or paint meeting the requirements of ASTM A 780. The zinc dust spray or paint shall be applied before corrosion appears and allowed to dry according to the manufacturer's specifications prior to another coat of zinc. This work shall be performed by the producer and included with the cost of the beam.
The contractor is advised that the existing Precast Prestressed Concrete Deck Beams are in a deteriorated condition with reduced load carrying capacity. It is the contractor's responsibility to account for the condition of the beams when developing construction procedures for removal and replacement of the beam.
Any damage done to the bridge during beam removal shall be repaired by the Contractor. Cost to be included in the cost of "Removal of Existing P.P.C. Deck Beams".

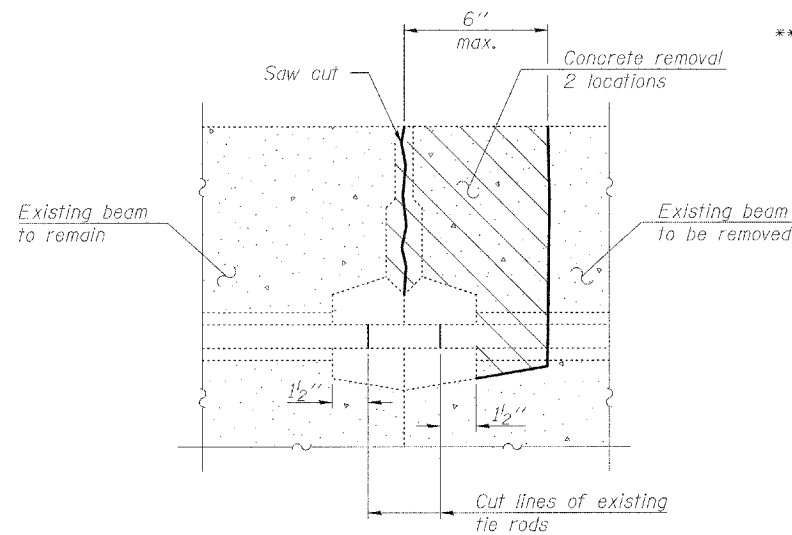

BEAM REMOVAL DETAIL
AT TRANSVERSE TIES

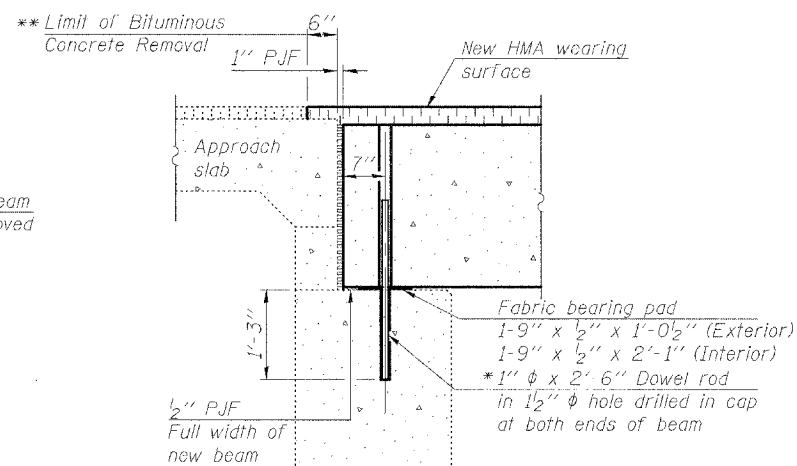

SECTION THRU ABUTMENTS

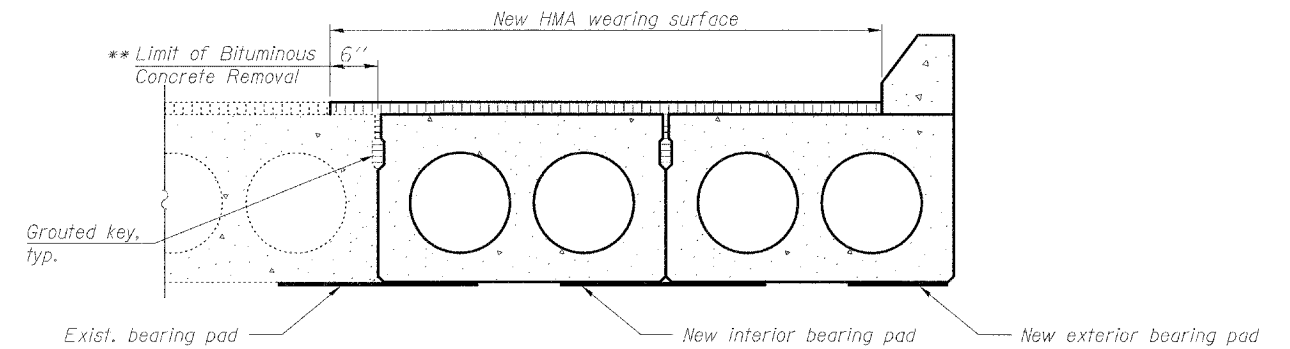

PARTIAL CROSS SECTION

BILL OF MATERIAL

Item	Unit	Total
Removal of Existing P.P.C. Deck Beams	Sq. Ft.	252
Hot Mix Asphalt Surface Course, Mix "C", N70	Ton	9

- * Exist. dowel rods shall be cut off and ground flush with cap. New dowel rods to be grouted after beam is in place and allowed to cure (24 hrs. min.) prior to grouting the shear key.
- ** The cost of bituminous concrete removal shall be included with Removal of Existing PPC Deck Beams.

DESIGN STRESSES

PRECAST PRESTRESSED UNITS

$f'_c = 5,000$ psi
 $f'_{ci} = 4,000$ psi
 $f'_s = 270,000$ psi ($1/2$ " ϕ low lax. strands)
 $f'_{si} = 201,960$ psi ($1/2$ " ϕ low lax. strands)

DESIGNED	JJD
CHECKED	EML
DRAWN	KLH
CHECKED	EML

HORNER & SHIFRIN, INC.
ENGINEERS

PRE-STAGE I DETAILS I
F.A.P. ROUTE 328 - SECTION (8BR-1)B-1
WAYNE COUNTY
STATION 719+63.09
STRUCTURE NO. 096-0020