

F.A.I. RTE.	SECTION	COUNTY	TOTAL SHEETS	SHEET NO.
270	60-(2,3)I	MADISON	32	1

STATE OF ILLINOIS
DEPARTMENT OF TRANSPORTATION
DIVISION OF HIGHWAYS

**PROPOSED
HIGHWAY PLANS**

FAI RTE 270 (I-270)
SECTION 60-(2,3)I
PROJECT: HSIP-270-6(099)002
HIGH TENSION CABLE MEDIAN BARRIER
MADISON COUNTY

C-98-049-06

D-98-060-06



LOCATION OF SECTION INDICATED THIS: —

FOR INDEX OF SHEETS, SEE SHEET NO. 2

HIGHWAY STANDARDS

- 000001-04
- 701101-01
- 701400-02
- 701406-04
- 701426-02
- 702001-06
- 435006-02
- 635011-01
- 701401-03

BEGIN
STA. 211+88
LAT: 38.76567
LONG: -90.13154

END
STA. 315+92
LAT: 38.75996
LONG: -90.04588

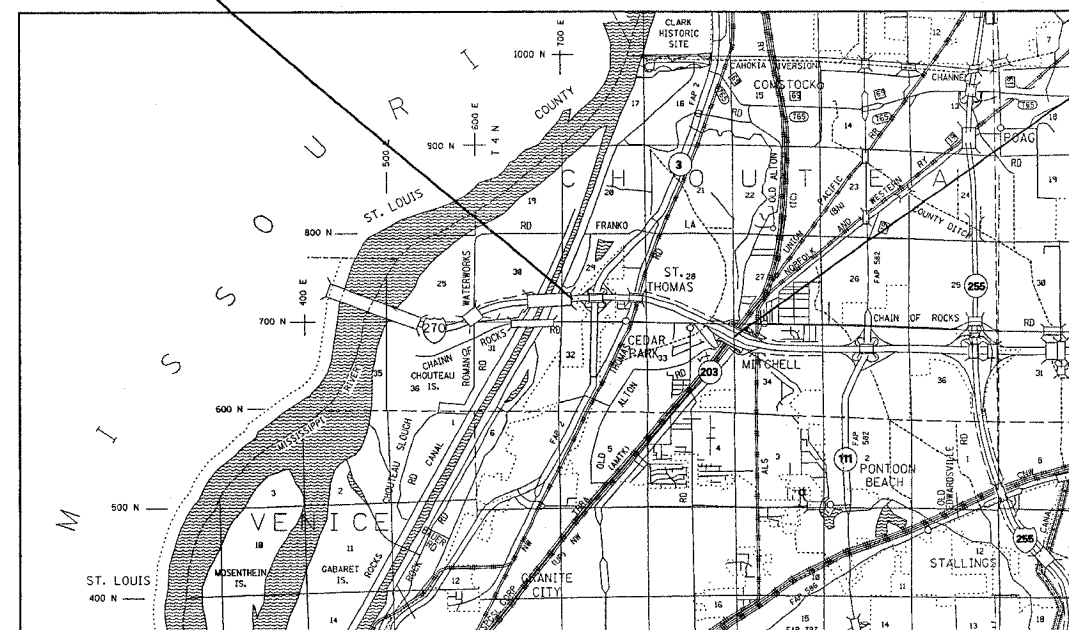

MICROFILMED _____
REEL NUMBER _____
AWARDED _____
RESIDENT ENGINEER _____
AS BUILT CHANGES WERE MADE
ON THE FOLLOWING SHEETS

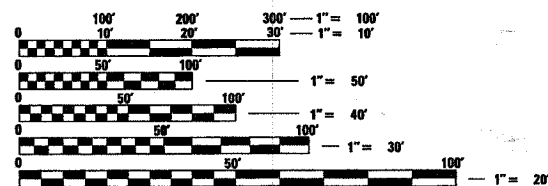

FULL SIZE PLANS HAVE BEEN PREPARED USING STANDARD ENGINEERING SCALES. REDUCED SIZED PLANS WILL NOT CONFORM TO STANDARD SCALES. IN MAKING MEASUREMENTS ON REDUCED PLANS, THE ABOVE SCALES MAY BE USED.

J.U.L.I.E.
JOINT UTILITY LOCATION INFORMATION FOR EXCAVATION
1-800-892-0123

DESIGN DESIGNATION

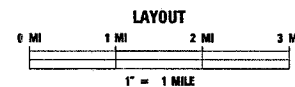

GROSS LENGTH = 10,404 FT = 1.97 MILES
NET LENGTH = 10,404 FT = 1.97 MILES

STATE OF ILLINOIS
DEPARTMENT OF TRANSPORTATION
DIVISION OF HIGHWAYS

SUBMITTED *March 22, 2007*

Mary C. James
DEPUTY DIRECTOR OF HIGHWAYS
REGION FIVE ENGINEER

May 14, 2007
Eric E. Hawn
ENGINEER OF DESIGN AND ENVIRONMENT

May 11, 2007
Milton R. Sees P.E.
DIRECTOR, DIVISION OF HIGHWAYS

**PRINTED BY THE AUTHORITY
OF THE STATE OF ILLINOIS**

PROJECT ENGINEER: PATTI LEBEAU 618-346-3179
SQUAD LEADER: CHERYL KEPLAR 618-346-3186

CONTRACT NO. 76A20

F.A.I. RTE.	SECTION	COUNTY	TOTAL SHEETS	SHEET NO.
270	60-(2,3)I	MADISON	32	2
STA.		TO STA.		
FED. ROAD DIST. NO.	ILLINOIS	FED. AID PROJECT		

GENERAL NOTES

- THE CONTRACTOR SHALL VERIFY ALL DIMENSIONS AND CONDITIONS IN THE FIELD PRIOR TO CONSTRUCTION AND ORDERING MATERIALS.
- ILLINOIS STATE LAW REQUIRES A 48 HOUR NOTICE TO BE GIVEN TO UTILITIES BEFORE DIGGING. FIELD MARKING OF FACILITIES MAY BE OBTAINED BY CONTACTING J.U.L.I.E. (PHONE: 800-892-0123) OR FOR NON MEMBERS, THE UTILITY COMPANIES DIRECTLY. AGENCIES KNOWN TO HAVE FACILITIES WITHIN THE PROJECT AREA ARE AS FOLLOWS:
 - AMEREN IP
 - AMEREN CIPS
 - BUCKEYE PARTNERS L.P.- WOOD RIVER PIPELINE
 - CENTERPOINT ENERGY
 - CHARTER COMMUNICATIONS, INC.
 - EXPLORER PIPELINE COMPANY
 - ILLINOIS AMERICAN WATER COMPANY
 - LEVEL 3 COMMUNICATIONS, LLC
 - VERIZON BUSINESS
 - MADISON COUNTY SPECIAL SERVICE AREA #1
 - MITCHELL PUBLIC WATER DISTRICT
 - 3GONETWORKS (USA) INC.
 - PONTOON BEACH PUBLIC WATER DISTRICT
 - AT&T CORPORATION
 - AT&T ILLINOIS
 - SPRINT/NEXTEL
 - CITY OF GRANITE CITY

MEMBERS OF J.U.L.I.E. (800) 892-0123 ARE INDICATED BY *. NON J.U.L.I.E. MEMBERS MUST BE CONTACTED INDIVIDUALLY.
- ALL EXCAVATION ADJACENT TO THE EDGE OF SHOULDER SHALL BE PROTECTED WITH EXTENDED LEG BARRICADES AND STEADY BURN LIGHTS.
- WHEN NO WORK IS BEING PERFORMED, THE FLAGGERS WILL NOT BE REQUIRED. IF FLAGGERS ARE NOT PRESENT, THE FLAGGER SIGNS SHALL BE REMOVED OR COVERED.
- FLAGMEN SHALL BE PRESENT DURING ALL CLOSURE HOURS, INCLUDING LUNCH HOUR, AND NO ADDITIONAL COMPENSATION WILL BE APPLIED.
- STANDARD 701101 SHALL BE USED FOR SHOULDER CLOSING WITH A SHOULDER CLOSED SIGN. THE COST SHALL BE INCLUDED IN THE TRAFFIC CONTROL PAY ITEMS.
- NO OVERNIGHT LANE CLOSURES WILL BE ALLOWED.
- ALL TRAFFIC CONTROL DEVICES SHALL BE SKID MOUNTED.
- 'ROAD CONSTRUCTION AHEAD' SIGNS SHALL BE PLACED AT THE BEGINNING OF THE PROJECT AND ALL ENTRANCE RAMPS; COST TO BE INCLUDED WITH THE TRAFFIC CONTROL PAY ITEMS. ALL CONSTRUCTION SIGNS SHALL BE FLUORESCENT ORANGE AND 48"X48".
- TOPOGRAPHIC SURVEY WAS PERFORMED FOR THE MEDIAN AREA ONLY. ALL OTHER ITEMS SHOWN WERE CREATED FROM OLD PLANS.
- BEGINNING AND END STATIONS AS SHOWN IN THE PLANS FOR HTC AND MOW STRIP ARE APPROXIMATE. THE R. E. WILL DETERMINE THE EXACT LOCATION.
- A QUANTITY FOR CLASS 2A SEEDING AND MULCH METHOD 1, (1.6 ACRES) HAS BEEN INCLUDED IN THE PLANS TO BE APPLIED TO ALL DISTURBED AREAS AS FINAL SEEDING. APPROPRIATE FERTILIZER NUTRIENTS PER SECTION 250 OF STANDARD SPECIFICATIONS SHALL BE APPLIED. FERTILIZER NUTRIENTS WILL NOT BE PAID FOR SEPARATELY, BUT WILL BE INCLUDED IN THE COST OF SEEDING CLASS 2A.
- THE MINIMUM DEPTH OF THE LINE POST FOUNDATIONS SHALL BE 30".
- THE FOLLOWING MIXTURE REQUIREMENTS APPLY TO THIS PROJECT.

MIXTURE USE	SHOULDERS
AC/PG	PG 58-22
RAP % (MAX)	30%
DESIGN AIR VOIDS	2.0% @ NDES=30
MIX COMPOSITION (GRADATION MIXTURE)	
FRICTION AGG	BAM
- ANY FURNISHED EXCAVATION REQUIRED TO MEET THE 4:1 SLOPE REQUIREMENTS FOR THE MOW STRIP WILL BE PAID FOR PER SECTION 109.04 OF THE STANDARD SPECIFICATIONS.
- THE LIMITS OF THE MOW STRIP SHALL BE THE SAME AS THE LIMITS OF THE HTC INCLUDING TERMINAL SECTIONS.
- REMOVED GUARDRAIL SHALL BECOME THE PROPERTY OF THE CONTRACTOR.
- DELINEATOR REMOVAL WILL NOT BE PAID FOR SEPARATELY BUT WILL BE INCLUDED IN THE COST FOR HOT-MIX ASPHALT SHOULDER, 4". REMOVED DELINEATORS SHALL BECOME PROPERTY OF THE CONTRACTOR.
- IN ADDITION TO THE PORTABLE CHANGEABLE MESSAGE SIGNS INCLUDED IN THE TRAFFIC CONTROL STANDARDS, 3 PORTABLE CHANGEABLE MESSAGE SIGN ARE INCLUDED AND SHALL BE PAID FOR PER SECTION 701 IN THE STANDARD SPECIFICATIONS. THEIR LOCATIONS TO BE DETERMINED BY THE ENGINEER. NO ADDITIONAL PAYMENT WILL BE ALLOWED FOR ANY RELOCATION OF THESE SIGNS.
- REFLECTORS FOR HTC SHALL BE PROVIDED AND INSTALLED PER MANUFACTURER'S SPECIFICATIONS FOR THE TYPE OF HTC BARRIER USED. COST SHALL BE INCLUDED IN HIGH TENSION CABLE MEDIAN BARRIER. MAXIMUM SPACING SHALL BE 50' OR AS DIRECTED BY THE ENGINEER.
- OPEN AUGER HOLES SHALL BE PROTECTED WITH BARRICADES WITH STEADY BURN LIGHTS AT 50' CENTERS AS DIRECTED BY THE ENGINEER. COST TO BE INCLUDED WITH TRAFFIC CONTROL PAY ITEMS.
- HTC SYSTEM SHALL BE CHOSEN FROM THE DEPARTMENT'S APPROVED LIST TO BE USED WHERE MEDIAN SLOPES ARE STEEPER THAN 1:6 AND AS STEEP AS 1:4.
- POST SPACING SHALL BE REDUCED IN FRONT OF MEDIAN HAZARDS AND FOR A DISTANCE OF 100' BEFORE AND 100' AFTER THE MEDIAN HAZARD AS SHOWN IN THE PLANS. THE POST SPACING SHALL BE REDUCED IN ORDER THAT A DEFLECTION OF <= 7" IS PROVIDED ACCORDING TO MANUFACTURER'S RECOMMENDATIONS AND AS SUPPORTED BY NCHRP 350 TESTING. COST FOR PROVIDING REDUCED POST SPACING WILL NOT BE PAID FOR SEPARATELY, BUT WILL BE INCLUDED IN THE CONTRACT UNIT PRICE FOR HIGH TENSION CABLE MEDIAN BARRIER.

- ALL WORK REQUIRED TO PLACE THE HOT MIX ASPHALT SHOULDER (MOW STRIP) INCLUDING, BUT NOT LIMITED TO SAW CUTTING AND THE REMOVAL OF EXISTING HOT MIX-ASPHALT SHOULDER, WILL NOT BE PAID FOR SEPARATELY, BUT SHALL BE INCLUDED IN THE COST FOR HOT-MIX ASPHALT SHOULDERS 4".
- THE CONTRACTOR SHALL HAVE ALL LANES OF TRAFFIC OPEN DURING PEAK HOURS IN EACH DIRECTION. THE CONTRACTOR WILL NOT BE ALLOWED TO CONDUCT ANY TYPE OF OPERATION IN THE OPEN LANES OR ANY TYPE OF OPERATION THAT WOULD IMPEDE THE FLOW OF TRAFFIC DURING PEAK HOURS. PEAK HOURS ARE DEFINED AS 6:00 AM TO 9:00 AM FOR THE WESTBOUND TRAFFIC AND 3:00 PM TO 6:00 PM FOR THE EASTBOUND TRAFFIC.
- AN ADDITIONAL QUANTITY FOR MULCH METHOD 1, (1.6 ACRES), HAS BEEN INCLUDED IN THE PLANS TO BE APPLIED TO ALL DISTURBED AREAS AS AN EROSION CONTROL MEASURE, AT THE DIRECTION OF THE ENGINEER. MULCH USED FOR EROSION CONTROL SHALL CONFORM TO SECTION 251 OF THE STANDARD SPECIFICATIONS.
- THE PROPOSED SPBCR AND TRAFFIC BARRIER TERMINALS SHOWN IN THE PLANS SHALL COMPLY WITH THE DETAILS IN THE PLANS IN ORDER TO MATCH THE EXISTING GUARDRAIL SYSTEM.

INDEX OF SHEETS

- COVER SHEET
- GENERAL NOTES, INDEX OF SHEETS, COMMITMENTS, STANDARDS AND ADT
- SUMMARY OF QUANTITIES
- 6. TYPICAL SECTIONS
- SCHEDULES
- 15. PLAN SHEETS
- HTC DETAILS
- 18. STORM WATER PREVENTION POLLUTION PLAN
- 26. EROSION CONTROL PLAN
- 32. GUARDRAIL DETAILS

ADT
CANAL BRIDGE TO IL RTE 3

2005 ADT = 54,200
2007 ADT = 55,300
2027 ADT = 67,500
SU = 3.0%
MU = 19.4%

IL RTE 3 TO IL RTE 203

2005 ADT = 48,600
2007 ADT = 49,600
2027 ADT = 67,500
SU = 3.2%
MU = 21.4%

COMMITMENTS:

NONE

DATE = DATE
FILE NAME = FILE
REFERENCE = REF

REVISIONS	
NAME	DATE

ILLINOIS DEPARTMENT OF TRANSPORTATION
GENERAL NOTES, INDEX OF SHEETS,
COMMITMENTS AND ADT

FAI RTE 270
SECTION 60-(2,3)I
MADISON COUNTY

SCALE: VERT.
DATE: HORIZ.

DRAWN BY
CHECKED BY

F.A.I. RTE.	SECTION	COUNTY	TOTAL SHEETS	SHEET NO.
270	60-(2,3)I	MADISON	32	4
STA.		TO STA.		
FED. ROAD DIST. NO.		ILLINOIS	FED. AID PROJECT	

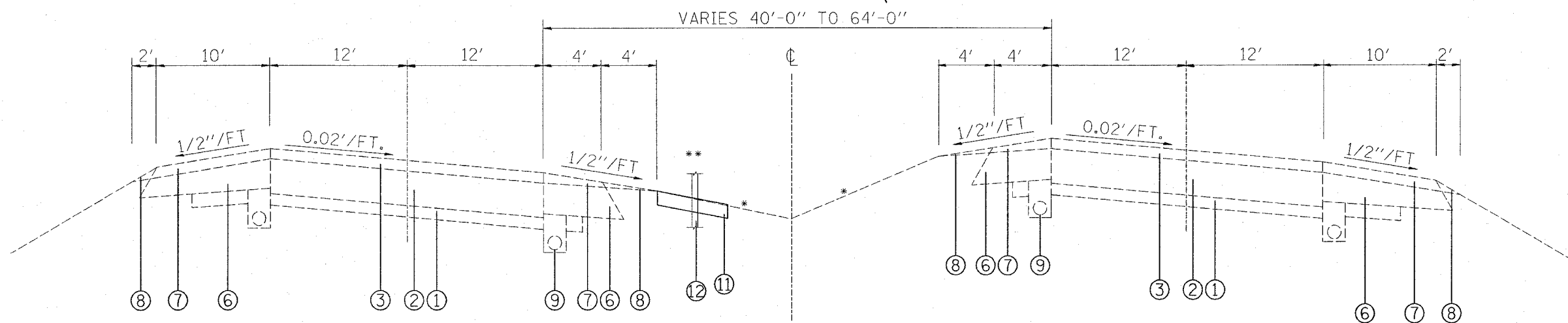

TYPICAL SECTION
STA. 235+10 TO STA. 289+94

LEGEND

- ① EXISTING 6" SUB-BASE GRANULAR MATERIAL
- ② EXISTING PCC PAVEMENT, 10"
- ③ EXISTING HOT-MIX ASPHALT OVERLAY
- ④ EXISTING CONCRETE MEDIAN
- ⑤ EXISTING COMB. CONC. CURB & GUTTER
- ⑥ EXISTING HOT-MIX ASPHALT SHOULDER
- ⑦ EXISTING HOT-MIX ASPHALT SHOULDER OVERLAY
- ⑧ EXISTING AGG. SHOULDER WEDGE
- ⑨ EXISTING UNDERDRAINS
- ⑩ EXISTING CONCRETE MEDIAN SURFACE
- ⑪ PROPOSED HOT MIX-ASPHALT SHOULDER, 4" (MOW STRIP)
- ⑫ PROPOSED HIGH TENSION CABLE MEDIAN BARRIER

* MEDIAN SLOPES VARY 4:1 AND FLATTER

** LOCATION OF HTC AND MOW STRIP VARIES BETWEEN EB AND WB LANES. SEE PLAN SHEETS FOR LOCATIONS.

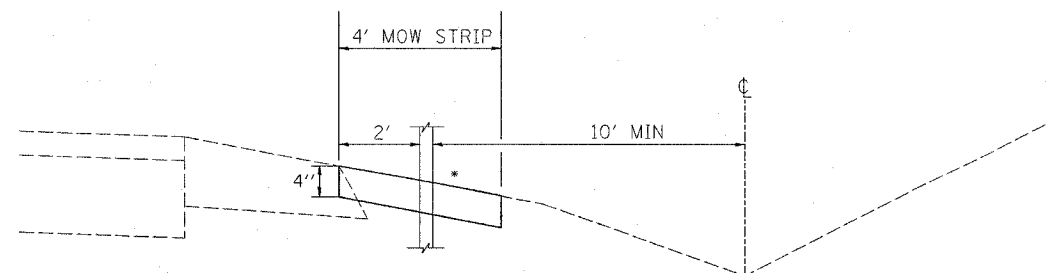

* MATCH EXISTING SLOPE;
MUST BE 4:1 OR FLATTER.
SEE GENERAL NOTE 15

PLOT DATE = #DATE#
FILE NAME = #FILE#
PLOT SCALE = #SCALE#
REFERENCE = #REF#

REVISIONS	
NAME	DATE

ILLINOIS DEPARTMENT OF TRANSPORTATION
TYPICAL SECTIONS
FAI RTE 270
SECTION 60-(2,3)I
MADISON COUNTY

SCALE: VERT. HORIZ.
DATE

DRAWN BY
CHECKED BY

F.A.I. RTE.	SECTION	COUNTY	TOTAL SHEETS	SHEET NO.
270	60-(2,3)I	MADISON	32	5
STA.		TO STA.		
FED. ROAD DIST. NO.		ILLINOIS FED. AID PROJECT		

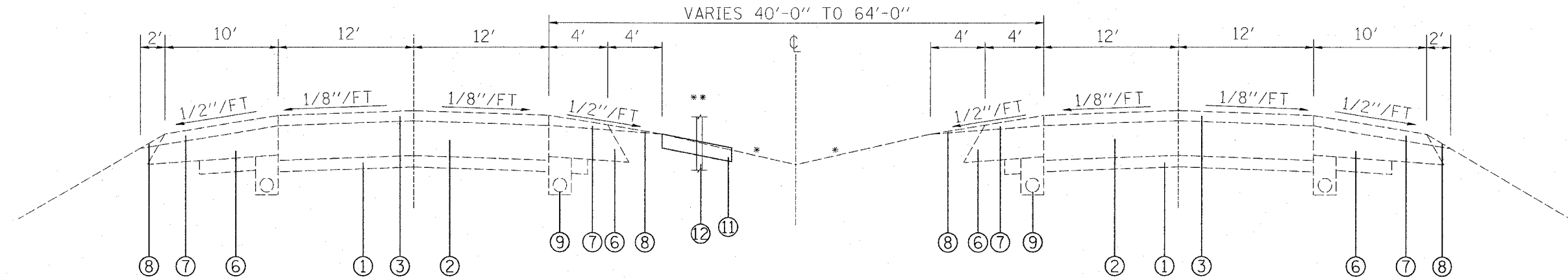

TYPICAL SECTION
 STA. 211+91 TO STA. 235+10
 STA. 289+94 TO STA. 296+35

LEGEND

- ① EXISTING 6" SUB-BASE GRANULAR MATERIAL
- ② EXISTING PCC PAVEMENT, 10"
- ③ EXISTING HOT-MIX ASPHALT OVERLAY
- ④ EXISTING CONCRETE MEDIAN
- ⑤ EXISTING COMB. CONC. CURB & GUTTER
- ⑥ EXISTING HOT-MIX ASPHALT SHOULDER
- ⑦ EXISTING HOT-MIX ASPHALT SHOULDER OVERLAY
- ⑧ EXISTING AGG. SHOULDER WEDGE
- ⑨ EXISTING UNDERDRAINS
- ⑩ EXISTING CONCRETE MEDIAN SURFACE
- ⑪ PROPOSED HOT MIX-ASPHALT SHOULDER, 4" (MOW STRIP)
- ⑫ PROPOSED HIGH TENSION CABLE MEDIAN BARRIER

* MEDIAN SLOPES VARY 4:1 AND FLATTER

** LOCATION OF HTC AND MOW STRIP VARIES BETWEEN EB AND WB LANES. SEE PLAN SHEETS FOR LOCATIONS.

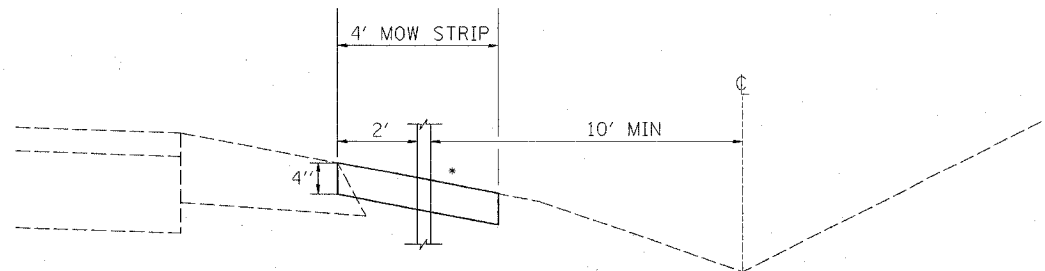

* MATCH EXISTING SLOPE;
 MUST BE 4:1 OR FLATTER.
 SEE GENERAL NOTE 15

REVISIONS	
NAME	DATE

ILLINOIS DEPARTMENT OF TRANSPORTATION
TYPICAL SECTIONS
 FAI RTE 270
 SECTION 60-(2,3)I
 MADISON COUNTY

SCALE: VERT.
 HORIZ.
 DATE

DRAWN BY
 CHECKED BY

PLOT DATE: 8/24/88
 FILE NAME: 76A20
 REFERENCE: 76A20

F.A.I. RTE.	SECTION	COUNTY	TOTAL SHEETS	SHEET NO.
270	60-(2,3)I	MADISON	32	6
STA.		TO STA.		
FED. ROAD DIST. NO.	ILLINOIS	FED. AID PROJECT		

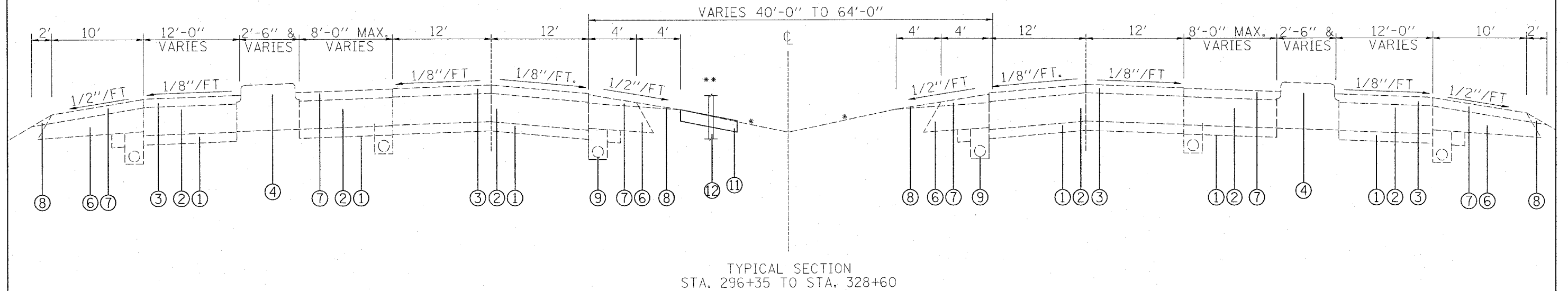

TYPICAL SECTION
STA. 296+35 TO STA. 328+60

LEGEND

- ① EXISTING 6" SUB-BASE GRANULAR MATERIAL
- ② EXISTING PCC PAVEMENT, 10"
- ③ EXISTING HOT-MIX ASPHALT OVERLAY
- ④ EXISTING CONCRETE MEDIAN
- ⑤ EXISTING COMB. CONC. CURB & GUTTER
- ⑥ EXISTING HOT-MIX ASPHALT SHOULDER
- ⑦ EXISTING HOT-MIX ASPHALT SHOULDER OVERLAY
- ⑧ EXISTING AGG. SHOULDER WEDGE
- ⑨ EXISTING UNDERDRAINS
- ⑩ EXISTING CONCRETE MEDIAN SURFACE
- ⑪ PROPOSED HOT MIX-ASPHALT SHOULDER, 4" (MOW STRIP)
- ⑫ PROPOSED HIGH TENSION CABLE MEDIAN BARRIER

* MEDIAN SLOPES VARY 4:1 AND FLATTER

** LOCATION OF HTC AND MOW STRIP VARIES BETWEEN EB AND WB LANES. SEE PLAN SHEETS FOR LOCATIONS.

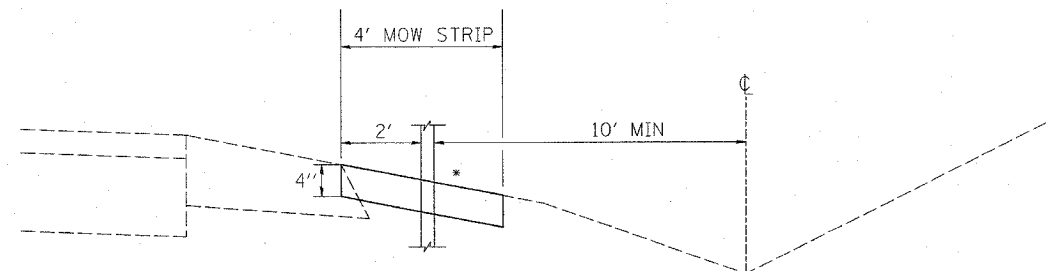

* MATCH EXISTING SLOPE;
MUST BE 4:1 OR FLATTER.
SEE GENERAL NOTE 15

PLOT DATE = #DATE*
FILE NAME = #FILE#*
PLOT SCALE = #SCALE#*
REFERENCE = #REF#*

REVISIONS	
NAME	DATE

ILLINOIS DEPARTMENT OF TRANSPORTATION
TYPICAL SECTIONS
FAI RTE 270
SECTION 60-(2,3)I
MADISON COUNTY

SCALE: VERT.
HORIZ.
DATE

DRAWN BY
CHECKED BY

F.A.I. RTE.	SECTION	COUNTY	TOTAL SHEETS	SHEET NO.
270	60-(2,3)I	MADISON	32	7
STA.		TO STA.		
FED. ROAD DIST. NO.		ILLINOIS FED. AID PROJECT		

HIGH TENSION CABLEMEDIAN BARRIER

RT/LT/CL	STATION	TO	STATION	HTC BARRIER	HTC BARRIER
				FOOT	TERMINAL EACH
RT	211+88		212+38		1
RT	212+38		214+29	191	
RT	214+29		214+79		1
LT	214+62		215+12		1
LT	215+12		221+50	638	
LT	221+50		222+00		1
RT	238+35		238+85		1
RT	238+85		241+00	215	
RT	241+00		249+62	862	
RT	249+62		250+12		1
LT	249+92		250+42		1
LT	250+42		254+78	436	
LT	254+78		255+28		1
RT	258+32		258+82		1
RT	258+82		261+49	267	
RT	261+49		261+99		1
LT	261+66		262+16		1
LT	262+16		271+00	884	
LT	271+00		286+00	1500	
LT	286+00		301+00	1500	
LT	301+00		315+42	1442	
LT	315+42		315+92		1
TOTAL				7935	12

HOT MIX ASPHALT SHOULDER, 4"

RT/LT	STATION	TO	STATION	LENGTH	WIDTH	SQ YD
RT	211+88		214+79	291	4	129
LT	214+62		222+00	738	4	328
RT	238+35		241+00	265	4	118
RT	241+00		250+12	912	4	405
LT	249+92		255+28	536	4	238
RT	258+32		261+99	367	4	163
LT	261+66		271+00	934	4	415
LT	271+00		286+00	1500	4	667
LT	286+00		301+00	1500	4	667
LT	301+00		315+92	1492	4	663
TOTAL						3793

SEEDING CLASS 2A

RT/LT/CL	STATION	TO	STATION	LENGTH	WIDTH	ACRE
RT	211+88		214+79	291	8	0.1
LT	214+62		222+00	738	8	0.1
RT	238+35		250+12	1177	8	0.2
LT	249+92		255+28	536	8	0.1
RT	258+32		261+99	367	8	0.1
LT	261+66		315+92	5426	8	1.0
TOTAL						1.6

GUARDRAIL SCHEDULE

RT/LT	STATION	TO	STATION	GUARDRAIL REMOVAL FOOT	STEEL PLATE BEAM GUARDRAIL TYPE A FOOT	TRAFFIC BARRIER TERMINAL TYPE 5 EACH	TRAFFIC BARRIER TERMINAL TY 1 SPL - TAN EACH	GUARDRAIL MARKERS TYPE A EACH	TERMINAL MARKERS DIRECT-APPL EACH	TRAFFIC BARRIER TERMINAL TYPE 2 EACH
RT	222+29		222+41	12.5						
LT	224+52		225+02	50						
RT	229+20		229+70	50						
LT	236+73		237+23	50						
RT	241+41		244+71	330						
LT	299+48		302+64	316						
TOTAL				808.5	1837.5	2	1	16	1	1

EARTHWORK SCHEDULE

LOCATION	EARTH EXCAVATION	EARTH EXCAVATION ADJ FOR SHRINKAGE (25%)	EMBANKMENT	EARTHWORK BALANCE WASTE (+) OR SHORTAGE (-)
	CUBIC YARD	CUBIC YARD	CUBIC YARD	CUBIC YARD
211+88 - 317+90	418	332	0	332
TOTAL				332

APPROXIMATELY 418 CY OF FURNISHED EXCAVATION WILL BE GENERATED BY THE PLACEMENT OF THE HMA SHOULDER (MOW STRIP).

THIS EARTH EXCAVATION MAY BE USED AS FURNISHED EXCAVATION REQUIRED TO MEET THE 4:1 SLOPE REQUIREMENTS AS SHOWN IN THE PLANS. ADDITIONAL FURNISHED EXCAVATION REQUIRED BEYOND WHAT IS PROVIDED AS SHOWN ABOVE SHALL BE PAID FOR PER SECTION 109.04 OF THE STANDARD SPECIFICATIONS.

ANY EXCESS EARTH EXCAVATION SHALL BE DISPOSED OF BY CONTRACTOR PER SECTION 202 OF THE STANDARD SPECIFICATIONS.

PLOT DATE = DATE
 PLOT SCALE = SCALE
 PLOT NUMBER = REFERENCE

REVISIONS		ILLINOIS DEPARTMENT OF TRANSPORTATION SCHEDULES FAI RTE 270 SECTION 60-(2,3)I MADISON COUNTY
NAME	DATE	
		SCALE: VERT. HORIZ. DATE
DRAWN BY		CHECKED BY

F.A.I. RTE.	SECTION	COUNTY	TOTAL SHEETS	SHEET NO.
270	60-(2,3)I	MADISON	32	8
STA.		TO STA.		
FED. ROAD DIST. NO.		ILLINOIS FED. AID PROJECT		

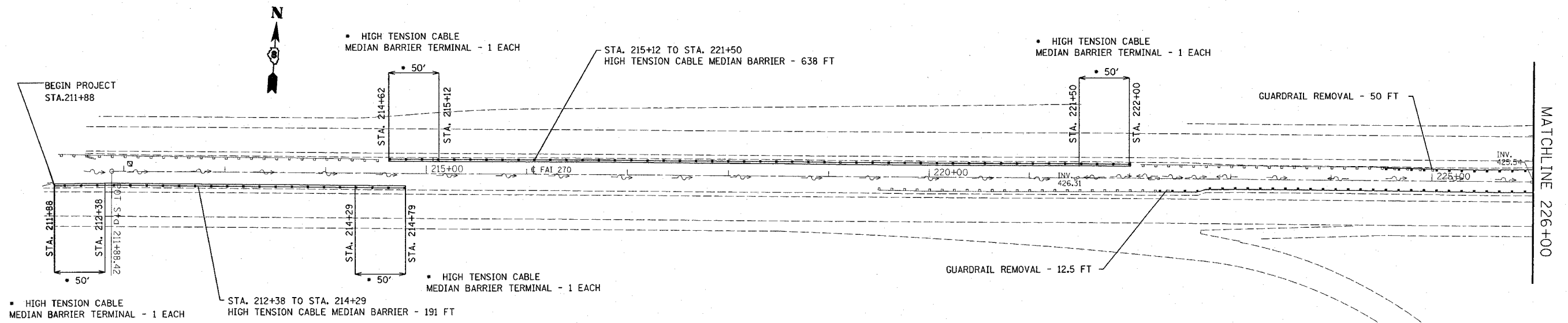

PLOT DATE = #DATE#
 FILE NAME = #FILE#
 SCALE = #SCALE#
 REFERENCE = #REF#

REVISIONS	
NAME	DATE

ILLINOIS DEPARTMENT OF TRANSPORTATION
PLAN VIEW
 FAI RTE 270
 SECTION 60-(2,3)I
 MADISON COUNTY

SCALE: VERT. _____
 HORIZ. _____
 DATE _____

DRAWN BY _____
 CHECKED BY _____

F.A.I. RTE.	SECTION	COUNTY	TOTAL SHEETS	SHEET NO.
270	60-(2,3)I	MADISON	32	9
STA.		TO STA.		
FED. ROAD DIST. NO.	ILLINOIS	FED. AID PROJECT		

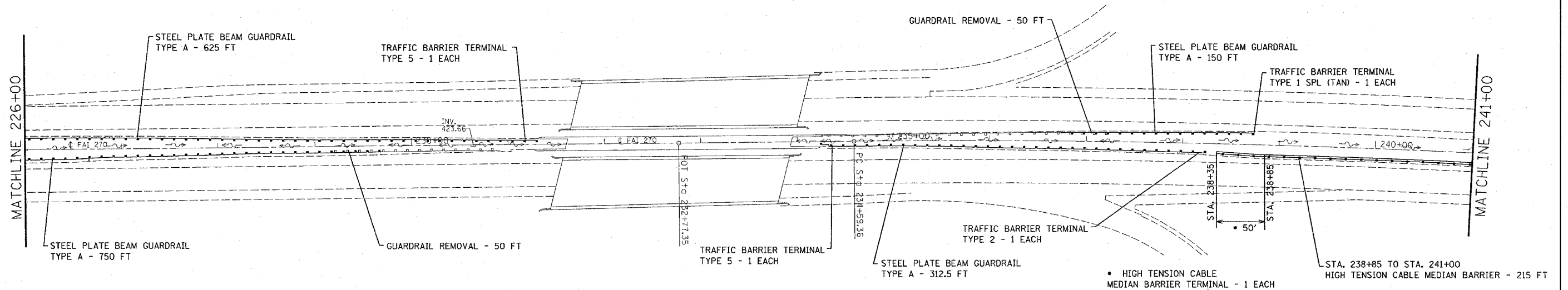

PLOT DATE * DATE *
 FILE NAME * FILE *
 REFERENCE * REF *

REVISIONS	
NAME	DATE

ILLINOIS DEPARTMENT OF TRANSPORTATION
PLAN VIEW
 FAI RTE 270
 SECTION 60-(2,3)I
 MADISON COUNTY

SCALE: VERT. DRAWN BY
 HORIZ. CHECKED BY
 DATE

F.A.I. RTE.	SECTION	COUNTY	TOTAL SHEETS	SHEET NO.
270	60-(2,3)I	MADISON	32	10
STA.		TO STA.		
FED. ROAD DIST. NO.	ILLINOIS	FED. AID PROJECT		

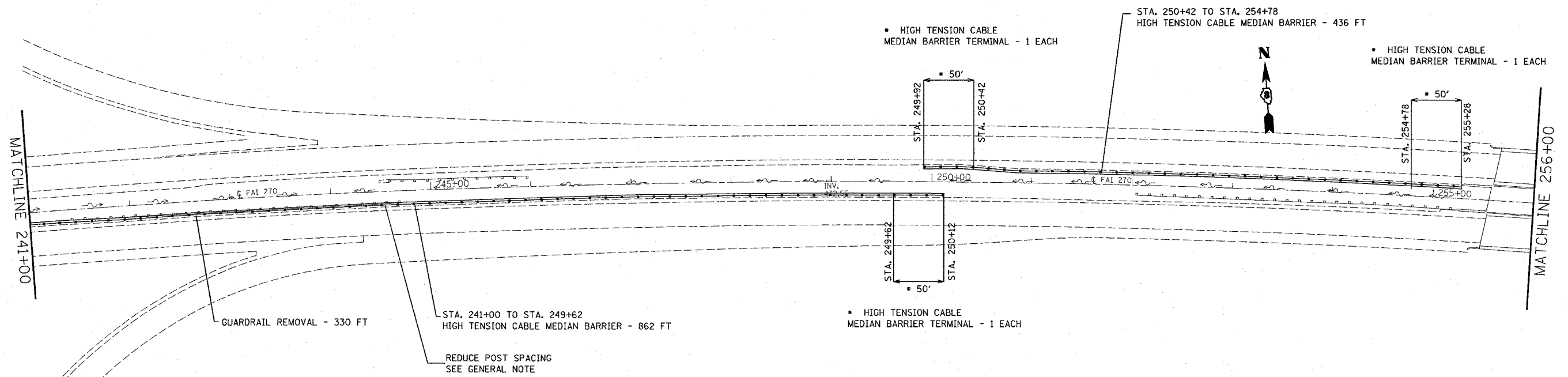

PLOT DATE = *DATE*
 TITLE = *TITLE*
 PLOT SCALE = *SCALE*
 REFERENCE = *REF*

REVISIONS	
NAME	DATE

ILLINOIS DEPARTMENT OF TRANSPORTATION
PLAN VIEW
 FAI RTE 270
 SECTION 60-(2,3)I
 MADISON COUNTY

SCALE: VERT. _____
 HORIZ. _____

DATE _____ DRAWN BY _____
 CHECKED BY _____

F.A.I. RTE.	SECTION	COUNTY	TOTAL SHEETS	SHEET NO.
270	60-(2,3)I	MADISON	32	11
STA.		TO STA.		
FED. ROAD DIST. NO.		ILLINOIS FED. AID PROJECT		

EXIST. CURVE C1
 PI STA. = 263+09.83
 $\Delta = 28^\circ 49' 51''$ (RT)
 $D = 0^\circ 31' 00''$
 $R = 11,089.50'$
 $T = 2,850.47'$
 $L = 5,580.15'$
 $E = 360.49'$
 $e = \text{-----}$
 $T.R. = \text{-----}$
 $S.E. RUN = \text{-----}$
 $P.C. STA. = 234+59.36$
 $P.T. STA. = 290+39.51$

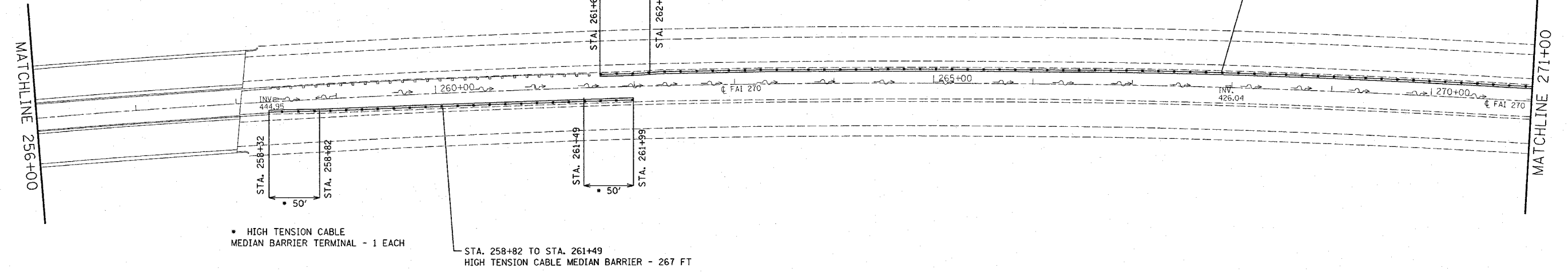

• HIGH TENSION CABLE
 MEDIAN BARRIER TERMINAL - 1 EACH

• HIGH TENSION CABLE
 MEDIAN BARRIER TERMINAL - 1 EACH

STA. 258+82 TO STA. 261+49
 HIGH TENSION CABLE MEDIAN BARRIER - 267 FT

STA. 262+16 TO STA. 271+00
 HIGH TENSION CABLE MEDIAN BARRIER - 884 FT

PLOT DATE = *DATE*
 FILE NAME = *FILE*
 PLOT SCALE = *SCALE*
 REFERENCE = *REF*

REVISIONS	
NAME	DATE

ILLINOIS DEPARTMENT OF TRANSPORTATION
PLAN VIEW
 FAI RTE 270
 SECTION 60-(2,3)I
 MADISON COUNTY

SCALE: VERT. _____
 HORIZ. _____

DATE _____ DRAWN BY _____
 CHECKED BY _____

F.A.I. RTE.	SECTION	COUNTY	TOTAL SHEETS	SHEET NO.
270	60-(2,3)I	MADISON	32	12
STA.		TO STA.		
FED. ROAD DIST. NO.		ILLINOIS FED. AID PROJECT		

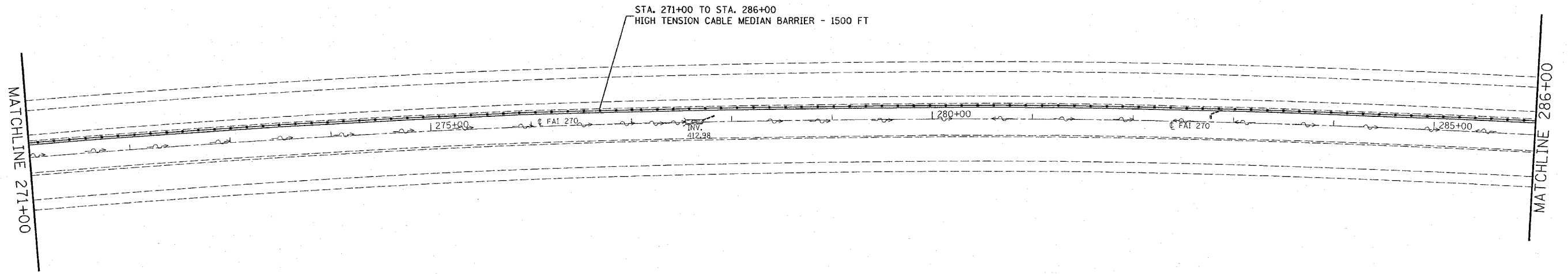

STA. 271+00 TO STA. 286+00
HIGH TENSION CABLE MEDIAN BARRIER - 1500 FT

MATCHLINE 271+00

MATCHLINE 286+00

PLOT DATE * DATE *
PLOT SCALE * SCALE *
REFERENCE * REF *

REVISIONS	
NAME	DATE

ILLINOIS DEPARTMENT OF TRANSPORTATION
PLAN VIEW
FAI RTE 270
SECTION 60-(2,3)I
MADISON COUNTY

SCALE: VERT. DRAWN BY
 HORIZ. CHECKED BY
DATE

F.A.I. RTE.	SECTION	COUNTY	TOTAL SHEETS	SHEET NO.
270	60-(2,3)I	MADISON	32	14
STA.		TO STA.		
FED. ROAD DIST. NO.		ILLINOIS FED. AID PROJECT		

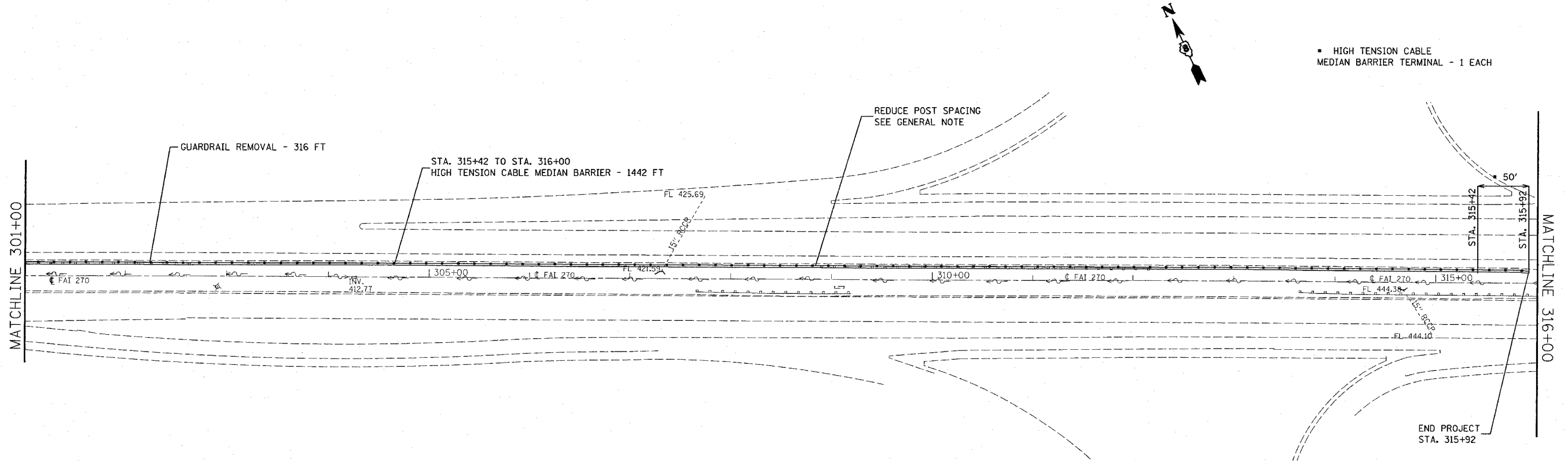

■ HIGH TENSION CABLE
MEDIAN BARRIER TERMINAL - 1 EACH

PLOT DATE = #DATE#
FILE NAME = #FILE#
PLOT SCALE = #SCALE#
REFERENCE = #REF#

REVISIONS	
NAME	DATE

ILLINOIS DEPARTMENT OF TRANSPORTATION
PLAN VIEW
FAI RTE 270
SECTION 60-(2,3)I
MADISON COUNTY
SCALE: VERT. _____
 HORIZ. _____
DATE _____ DRAWN BY _____
 CHECKED BY _____

F.A.I. RTE.	SECTION	COUNTY	TOTAL SHEETS	SHEET NO.
270	60-(2,3)I	MADISON	32	15
STA.		TO STA.		
FED. ROAD DIST. NO.		ILLINOIS FED. AID PROJECT		

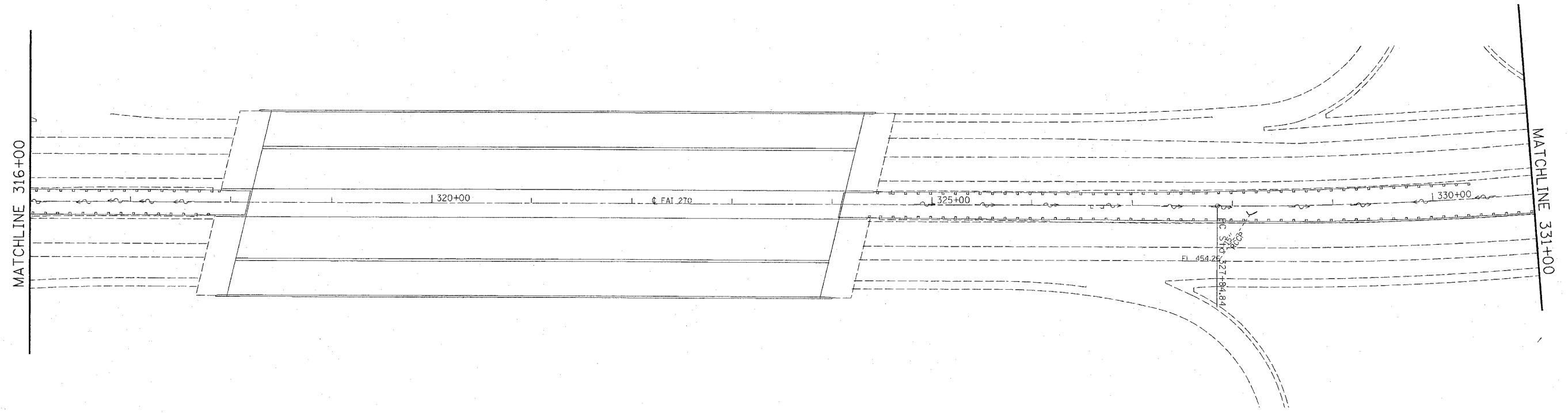

PLOT DATE = #DATE#
 FILE NAME = #FILE#
 PLOT SCALE = #SCALE#
 REFERENCE = #REF#

REVISIONS	
NAME	DATE

ILLINOIS DEPARTMENT OF TRANSPORTATION
PLAN VIEW
 FAI RTE 270
 SECTION 60-(2,3)I
 MADISON COUNTY

SCALE: VERT. _____
 HORIZ. _____
 DATE _____

DRAWN BY _____
 CHECKED BY _____

F.A.I. RTE.	SECTION	COUNTY	TOTAL SHEETS	SHEET NO.
270	60-(2,3)I	MADISON	32	16
STA.		TO STA.		
FED. ROAD DIST. NO.	ILLINOIS	FED. AID PROJECT		

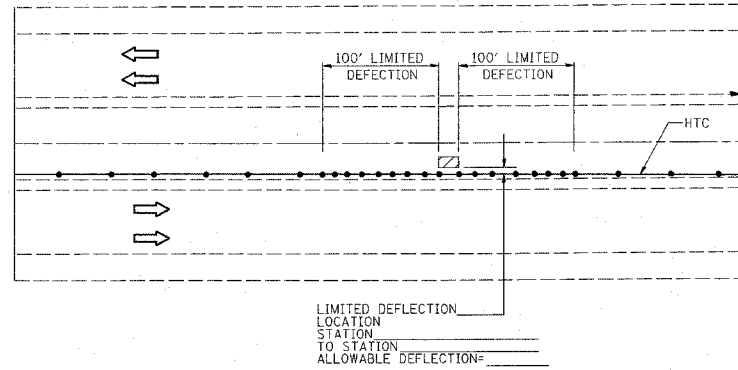

HTC LAYOUT & PLAN NOTATION FOR LIMITED DEFLECTION LOCATION

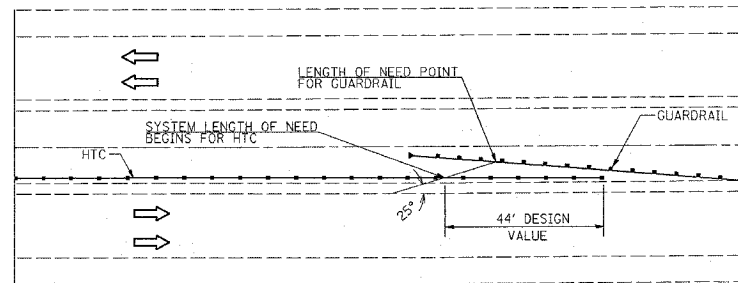

HTC LAYOUT FOR TERMINATION IN FRONT OF FLARED GUARDRAIL

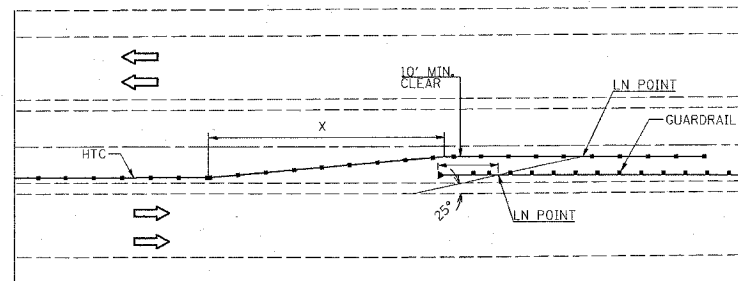

HTC LAYOUT FOR TERMINATION BEHIND TANGENT GUARDRAIL

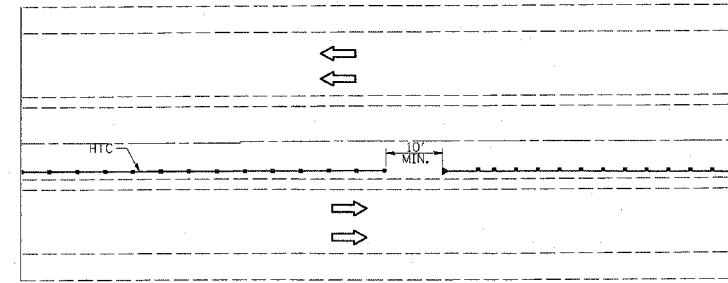

HTC LAYOUT ADJACENT TO GUARDRAIL

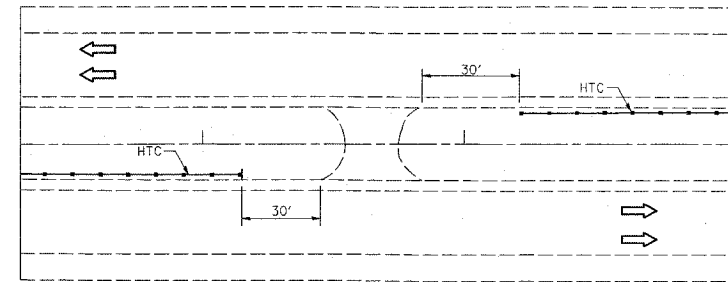

HTC LAYOUT AT MEDIAN CROSSOVERS

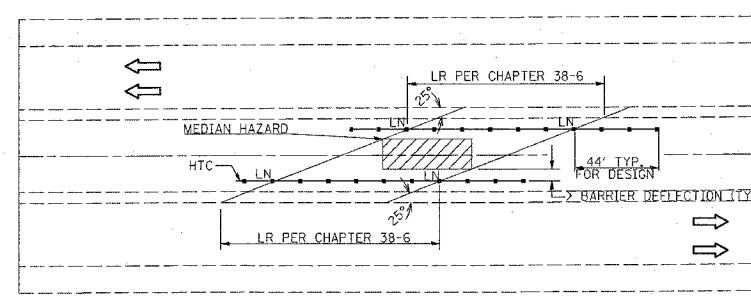

HTC LAYOUT FOR MEDIAN HAZARD PROTECTION

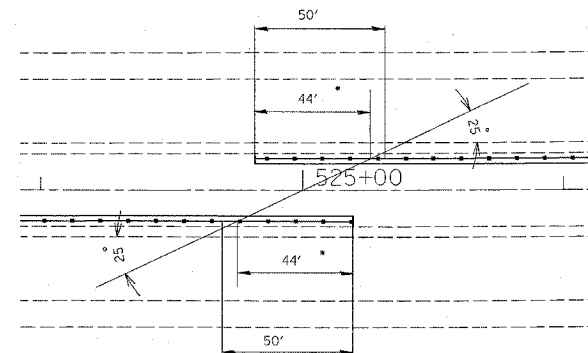

HTC LAYOUT FOR PLACEMENT ON OPPOSITE SIDES

• FOR PURPOSES OF HTC LAYOUT SHOWN IN PLANS, 44' FOR LON POINT WAS USED. ACTUAL LON POINT WILL VARY DEPENDING ON HTC SYSTEM USED.

PAY LENGTH FOR HTC MEDIAN BARRIER TERMINAL IS 50' REGARDLESS OF LON POINT.

PLOT DATE = #DATE#
 FILE NAME = #FILE#
 PLOT SCALE = #SCALE#
 REFERENCE = #REF#

REVISIONS	
NAME	DATE

ILLINOIS DEPARTMENT OF TRANSPORTATION
HTC DETAILS
 FAI RTE 270
 SECTION 60-(2,3)I
 MADISON COUNTY

SCALE: VERT. _____
 HORIZ. _____

DRAWN BY _____
 CHECKED BY _____

F.A.I. RTE.	SECTION	COUNTY	TOTAL SHEETS	SHEET NO.
270	60-(2,3)I	MADISON	32	17
STA.		TO STA.		
FED. ROAD DIST. NO.	ILLINOIS	FED. AID PROJECT		

DESCRIPTION OF STABILIZATION PRACTICES DURING CONSTRUCTION:

1. DURING CONSTRUCTION, AREAS OUTSIDE THE CONSTRUCTION LIMITS AS OUTLINED PREVIOUSLY HEREIN SHALL BE PROTECTED. THE CONTRACTOR SHALL NOT USE THIS AREA FOR STAGING (EXCEPT AS DESCRIBED ON THE PLANS AND DIRECTED BY THE ENGINEER), PARKING OF VEHICLES OR CONSTRUCTION EQUIPMENT, STORAGE OF MATERIALS, OR OTHER CONSTRUCTION RELATED ACTIVITIES.
 - (a.) WITHIN THE CONSTRUCTION LIMITS, AREAS WHICH MAY BE SUSCEPTIBLE TO EROSION AS DETERMINED BY THE ENGINEER SHALL REMAIN UNDISTURBED UNTIL FULL SCALE CONSTRUCTION IS UNDERWAY TO PREVENT UNNECESSARY SOIL EROSION.
 - (b.) EARTH STOCKPILES SHALL BE TEMPORARILY SEEDED IF THEY ARE TO REMAIN UNUSED FOR MORE THAN FOURTEEN DAYS.
 - (c.) AS CONSTRUCTION PROCEEDS, THE CONTRACTOR SHALL INSTITUTE THE FOLLOWING AS DIRECTED BY THE ENGINEER:
 - I. PLACE TEMPORARY EROSION CONTROL FACILITIES AT LOCATIONS SHOWN ON THE PLANS.
 - II. TEMPORARILY SEED ERODABLE BARE EARTH ON A WEEKLY BASIS TO MINIMIZE THE AMOUNT OF ERODABLE SURFACE AREA WITHIN THE CONTRACT LIMITS.
 - III. CONSTRUCT ROADSIDE DITCHES AND PROVIDE TEMPORARY EROSION CONTROL SYSTEMS.
 - IV. TEMPORARILY DIVERT WATER AROUND PROPOSED CULVERT LOCATIONS.
 - V. BUILD NECESSARY EMBANKMENT AT CULVERT LOCATIONS AND THEN EXCAVATE AND PLACE CULVERT.
 - VI. CONTINUE BUILDING UP THE EMBANKMENT TO THE PROPOSED GRADE WHILE AT THE SAME TIME, PLACING PERMANENT CONTROL SUCH AS RIPRAP DITCH LINING AND CONDUCTING FINAL SHAPING TO THE SLOPES.
 - (d.) EXCAVATED AREAS AND EMBANKMENT SHALL BE PERMANENTLY SEEDED IMMEDIATELY AFTER FINAL GRADING. IF NOT, THEY SHALL BE TEMPORARILY SEEDED IF NO CONSTRUCTION ACTIVITY IN THE AREA IS PLANNED FOR 7 DAYS.
 - (e.) CONSTRUCTION EQUIPMENT SHALL BE STORED AND FUELED ONLY AT DESIGNATED LOCATIONS. ALL NECESSARY MEASURES SHALL BE TAKEN TO CONTAIN ANY FUEL OF OTHER POLLUTANT IN ACCORDANCE WITH EPA WATER QUALITY REGULATIONS. LEAKING EQUIPMENT OR SUPPLIES SHALL BE IMMEDIATELY REPAIRED OR REMOVED FROM THE SITE.
 - (f.) THE RESIDENT ENGINEER SHALL INSPECT THE PROJECT DAILY DURING CONSTRUCTION ACTIVITIES. INSPECTION SHALL ALSO BE DONE WEEKLY AND AFTER RAINS OF 1/2 INCH OR GREATER OR EQUIVALENT SNOWFALL AND DURING THE WINTER SHUTDOWN PERIOD. THE PROJECT SHALL ADDITIONALLY BE INSPECTED BY THE CONSTRUCTION FIELD ENGINEER ON A BI-WEEKLY BASIS TO DETERMINE THAT EROSION CONTROL EFFORTS ARE IN PLACE AND EFFECTIVE AND IF OTHER EROSION CONTROL WORK IS NECESSARY.
 - (g) SEDIMENT COLLECTED DURING CONSTRUCTION OF THE VARIOUS TEMPORARY EROSION CONTROL SYSTEMS SHALL BE DISPOSED OF ON THE SITE ON A REGULAR BASIS AS DIRECTED BY THE ENGINEER. THE COST OF THIS MAINTENANCE SHALL BE INCLUDED IN THE UNIT BID PRICE FOR EARTH EXCAVATION.
 - (h) THE TEMPORARY EROSION CONTROL SYSTEMS SHALL BE REMOVED AS DIRECTED BY THE ENGINEER AFTER USE IS NO LONGER NEEDED OR NO LONGER FUNCTIONING. THE COST OF THIS REMOVAL SHALL BE INCLUDED IN THE UNIT BID PRICE FOR TEMPORARY EROSION CONTROL SYSTEM.

DESCRIPTION OF STRUCTURAL PRACTICES AFTER FINAL GRADING:

1. TEMPORARY EROSION CONTROL SYSTEMS SHALL BE LEFT IN PLACE WITH PROPER MAINTENANCE UNTIL PERMANENT EROSION CONTROL IS IN PLACE AND WORKING PROPERLY AND ALL PROPOSED TURF AREAS SEEDED AND ESTABLISHED.
2. ONCE PERMANENT EROSION CONTROL SYSTEMS AS PROPOSED IN THE PLANS ARE FUNCTIONAL AND ESTABLISHED, TEMPORARY ITEMS SHALL BE REMOVED, CLEANED UP, AND DISTURBED TURF RESEDED.







MAINTENANCE AFTER CONSTRUCTION:

1. CONSTRUCTION IS COMPLETE AFTER ACCEPTANCE BY I. D. O. T. FINAL INSPECTION. MAINTENANCE UP TO THIS DATE WILL BE BY THE CONTRACTOR.

MISCELLANEOUS:

1. A QUANTITY FOR MULCH METHOD 1, BASED ON AN ESTIMATED 8' WIDE AREA (1.6 ACRES), HAS BEEN INCLUDED IN THE PLANS TO BE APPLIED TO ALL DISTURBED AREAS AS AN EROSION CONTROL MEASURE AT THE DIRECTION OF THE ENGINEER. MULCH USED FOR EROSION CONTROL WILL BE PAID FOR SEPARATELY AND SHALL CONFORM TO SECTION 251 OF THE STANDARD SPECIFICATIONS. ANY DISTURBANCE BEYOND THE 8' WIDTH, MEASURED FROM THE EDGE OF EXISTING SHOULDER, SHALL BE MULCHED PER SECTION 251 AND SHALL BE AT THE CONTRACTOR'S EXPENSE.

LEGEND

	TEMPORARY DITCH CHECK- ROLLED EXCELSIOR, SILT WEDGES/PANELS
	TEMPORARY DITCH CHECK- AGGREGATE
	EROSION CONTROL BLANKET
	PERIMETER EROSION BARRIER- SILT FILTER FENCE OR OTHER AS APPROVED BY THE ENGINEER
	INLET AND PIPE PROTECTION- STRAW BALES, FILTER FABRIC, AGGREGATES
	MULCH

PLOT DATE = #DATE#
 FILE NAME = #FILE#
 PLOT SCALE = #SCALE#
 REFERENCE = #REF#

REVISIONS	
NAME	DATE

ILLINOIS DEPARTMENT OF TRANSPORTATION
**STORM WATER POLLUTION
 PREVENTION PLAN**
 FAI RTE 270
 SECTION 60-(2,3)I
 MADISON COUNTY

SCALE: VERT. _____
 HORIZ. _____
 DATE _____

DRAWN BY _____
 CHECKED BY _____

F.A.I. RTE.	SECTION	COUNTY	TOTAL SHEETS	SHEET NO.
270	60-(2,3)I	MADISON	32	19
STA.		TO STA.		
FED. ROAD DIST. NO.	ILLINOIS	FED. AID PROJECT		

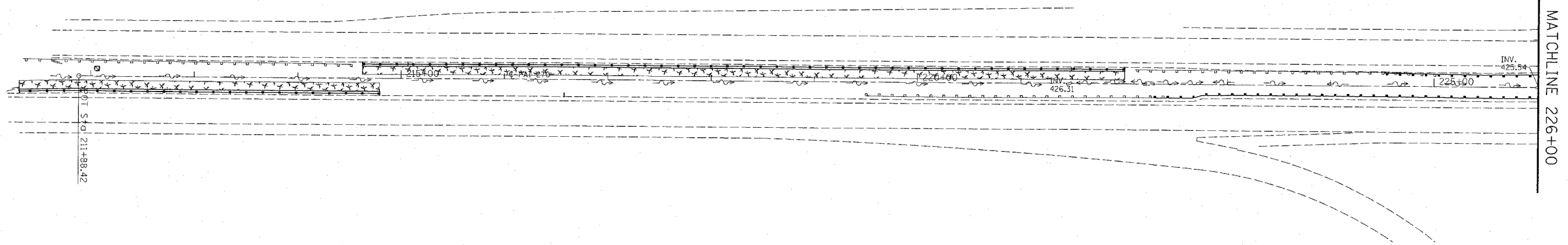

 MULCH

PLOT DATE = #DATE#
 FILE NAME = #FILE#
 PLOT SCALE = #SCALE#
 REFERENCE = #REF#

REVISIONS	
NAME	DATE

ILLINOIS DEPARTMENT OF TRANSPORTATION
EROSION CONTROL PLAN
 FAI RTE 270
 SECTION 60-(2,3)I
 MADISON COUNTY
 SCALE: VERT. _____
 DATE _____
 DRAWN BY _____
 CHECKED BY _____

F.A.I. RTE.	SECTION	COUNTY	TOTAL SHEETS	SHEET NO.
270	60-(2,3)I	MADISON	32	20
STA.		TO STA.		
FED. ROAD DIST. NO.		ILLINOIS FED. AID PROJECT		

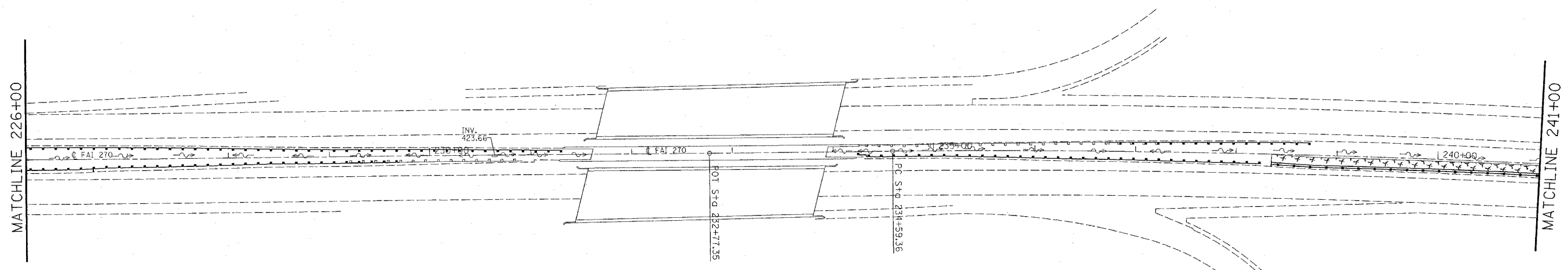

MULCH

PLOT DATE = #DATE#
 FILE NAME = #FILE#
 PLOT SCALE = #SCALE#
 REFERENCE = #REF#

REVISIONS	
NAME	DATE

ILLINOIS DEPARTMENT OF TRANSPORTATION
EROSION CONTROL PLAN
 FAI RTE 270
 SECTION 60-(2,3)I
 MADISON COUNTY

SCALE: VERT. _____
 HORIZ. _____

DATE _____ DRAWN BY _____
 CHECKED BY _____

F.A.I. RTE.	SECTION	COUNTY	TOTAL SHEETS	SHEET NO.
270	60-(2,3)I	MADISON	32	21
STA.		TO STA.		
FED. ROAD DIST. NO.		ILLINOIS FED. AID PROJECT		

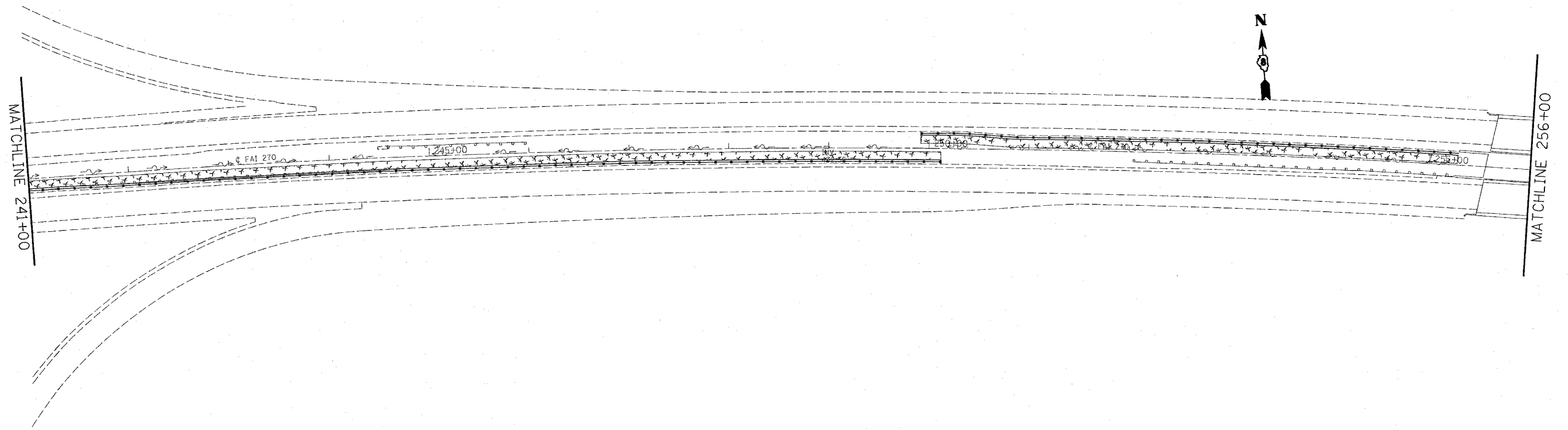

 MULCH

PLOT DATE * DATE *
 PLOT SCALE * SCALE *
 REFERENCE * REF *

REVISIONS	
NAME	DATE

ILLINOIS DEPARTMENT OF TRANSPORTATION
EROSION CONTROL PLAN
 FAI RTE 270
 SECTION 60-(2,3)I
 MADISON COUNTY

SCALE: VERT.
 HORIZ.
 DATE

DRAWN BY
 CHECKED BY

F.A.I. RTE.	SECTION	COUNTY	TOTAL SHEETS	SHEET NO.
270	60-(2,3)I	MADISON	32	22
STA.		TO STA.		
FED. ROAD DIST. NO.	ILLINOIS	FED. AID PROJECT		

EXIST. CURVE C1
 PI STA. = 263+09.83
 $\Delta = 28^\circ 49' 51''$ (RT)
 $D = 0^\circ 31' 00''$
 $R = 11,089.50'$
 $T = 2,850.47'$
 $L = 5,580.15'$
 $E = 360.49'$
 $\theta = \text{-----}$
 $T.R. = \text{-----}$
 $S.E. RUN = \text{-----}$
 $P.C. STA. = 234+59.36$
 $P.T. STA. = 290+39.51$

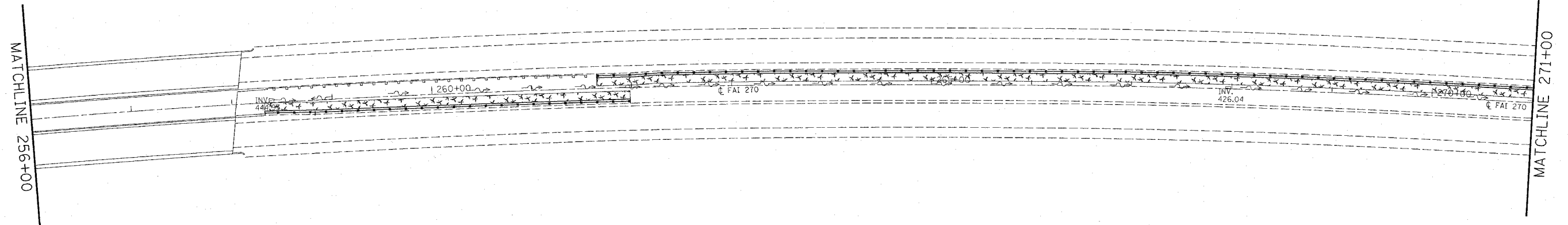

 MULCH

PLOT DATE = #DATE#
 FILE NAME = #FILE#
 PLOT SCALE = #SCALE#
 REFERENCE = #REF#

REVISIONS	
NAME	DATE

ILLINOIS DEPARTMENT OF TRANSPORTATION
EROSION CONTROL PLAN
 FAI RTE 270
 SECTION 60-(2,3)I
 MADISON COUNTY

SCALE: VERT. _____
 HORIZ. _____
 DATE _____
 DRAWN BY _____
 CHECKED BY _____

F.A.I. RTE.	SECTION	COUNTY	TOTAL SHEETS	SHEET NO.
270	60-(2,3)I	MADISON	32	23
STA.		TO STA.		
FED. ROAD DIST. NO.	ILLINOIS	FED. AID PROJECT		

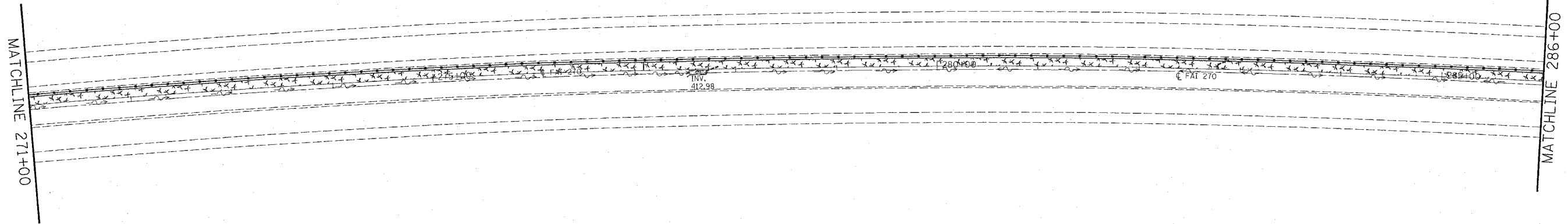

 MULCH

PLOT DATE * * DATE *
 FILE NAME * * FILE *
 REFERENCE * * REF *

REVISIONS	
NAME	DATE

ILLINOIS DEPARTMENT OF TRANSPORTATION
EROSION CONTROL PLAN
 FAI RTE 270
 SECTION 60-(2,3)I
 MADISON COUNTY

SCALE: VERT.
 DATE: HORIZ.

DRAWN BY
 CHECKED BY

F.A.I. RTE.	SECTION	COUNTY	TOTAL SHEETS	SHEET NO.
270	60-(2,3)I	MADISON	32	24
STA.		TO STA.		
FED. ROAD DIST. NO.		ILLINOIS FED. AID PROJECT		

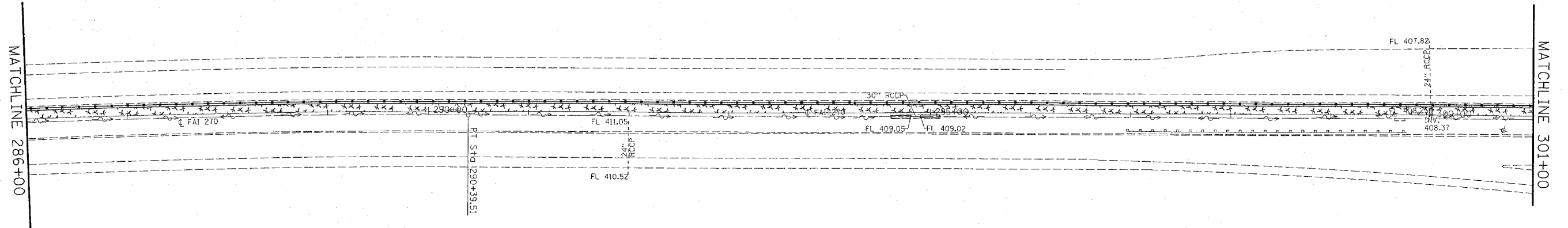

 MULCH

PLOT DATE = #DATE
 FILE NAME = #FILE
 PLOT SCALE = #SCALE
 REFERENCE = #REF

REVISIONS	
NAME	DATE

ILLINOIS DEPARTMENT OF TRANSPORTATION
EROSION CONTROL PLAN
 FAI RTE 270
 SECTION 60-(2,3)I
 MADISON COUNTY
 SCALE: VERT. _____
 DATE _____
 DRAWN BY _____
 CHECKED BY _____

F.A.I. RTE.	SECTION	COUNTY	TOTAL SHEETS	SHEET NO.
270	60-(2,3)I	MADISON	32	25
STA.		TO STA.		
FED. ROAD DIST. NO.		ILLINOIS FED. AID PROJECT		

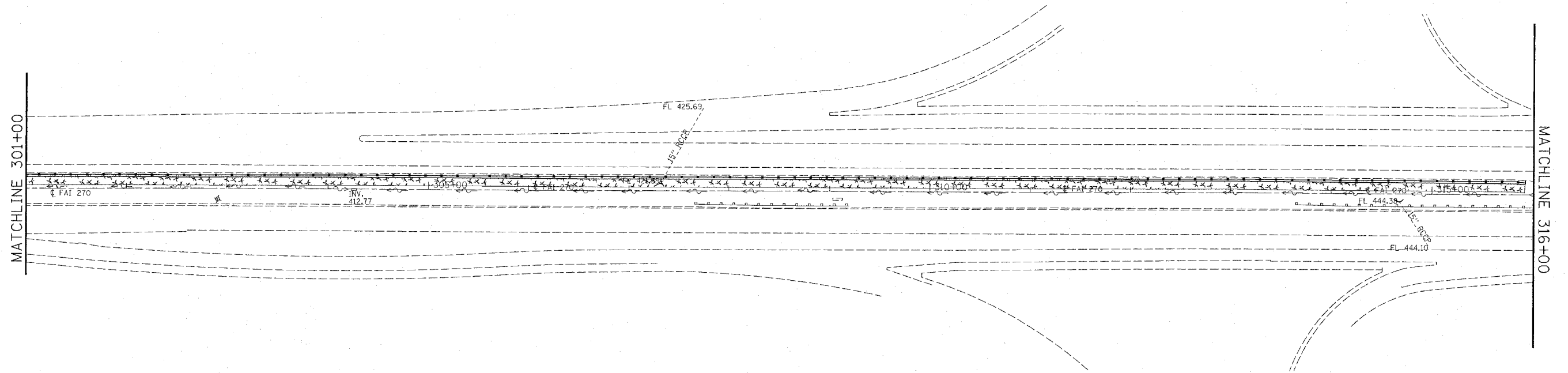

MATCHLINE 301+00

MATCHLINE 316+00



MULCH

* DATE *
 * FILE NAME *
 * PLOT SCALE *
 * REFERENCE *

REVISIONS	
NAME	DATE

ILLINOIS DEPARTMENT OF TRANSPORTATION
EROSION CONTROL PLAN
 FAI RTE 270
 SECTION 60-(2,3)I
 MADISON COUNTY

SCALE: VERT. _____
 HORIZ. _____
 DATE _____

DRAWN BY _____
 CHECKED BY _____

F.A.I. RTE.	SECTION	COUNTY	TOTAL SHEETS	SHEET NO.
270	60-(2,3)I	MADISON	32	26
STA.		TO STA.		
FED. ROAD DIST. NO.		ILLINOIS FED. AID PROJECT		

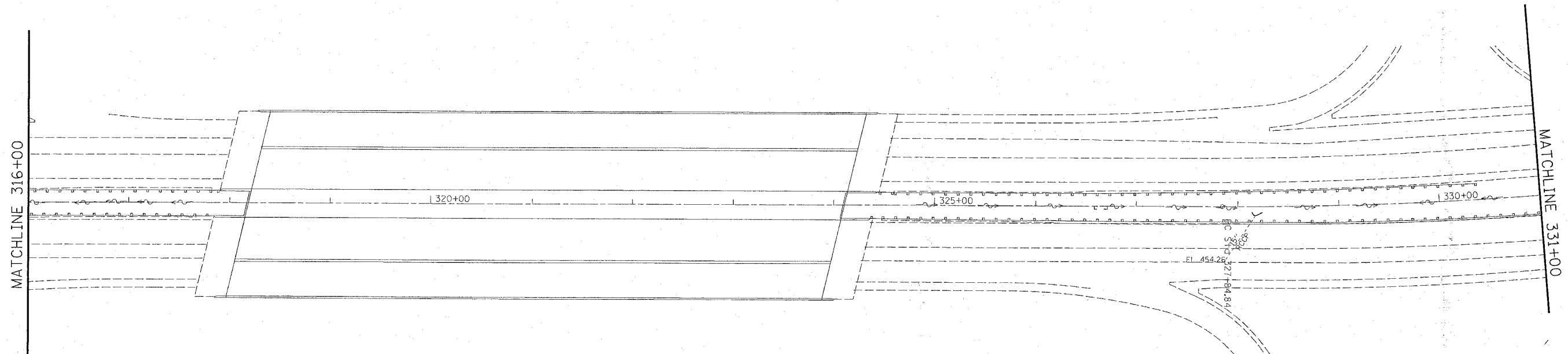

 MULCH

PLOT DATE = 3/20/2007
 FILE NAME = c:\projects\76a20\eroc\eroc.dgn
 PLOT SCALE = 8/11/00 / IN.
 REFERENCE = #REF#

REVISIONS	
NAME	DATE

ILLINOIS DEPARTMENT OF TRANSPORTATION
EROSION CONTROL PLAN
 FAI RTE 270
 SECTION 60-(2,3)I
 MADISON COUNTY

SCALE: VERT. _____
 HORIZ. _____
 DATE _____

DRAWN BY _____
 CHECKED BY _____

CONTRACT NO. 76A20				
F.A.I. RTE.	SECTION	COUNTY	TOTAL SHEETS	SHEET NO.
64	60-(2,3)I	MADISON	32	27
STA.		TO STA.		
FED. ROAD DIST. NO.		ILLINOIS FED. AID PROJECT		

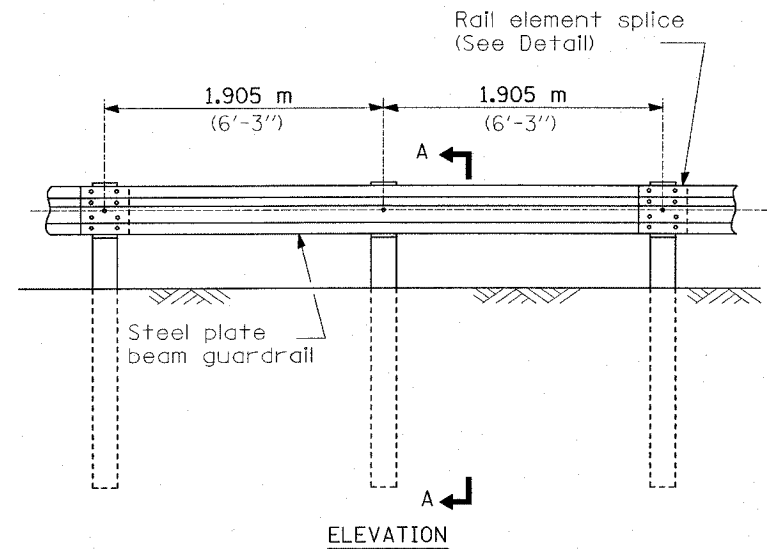

ELEVATION

TYPE A

1.905 m (6'-3") Typical post spacing

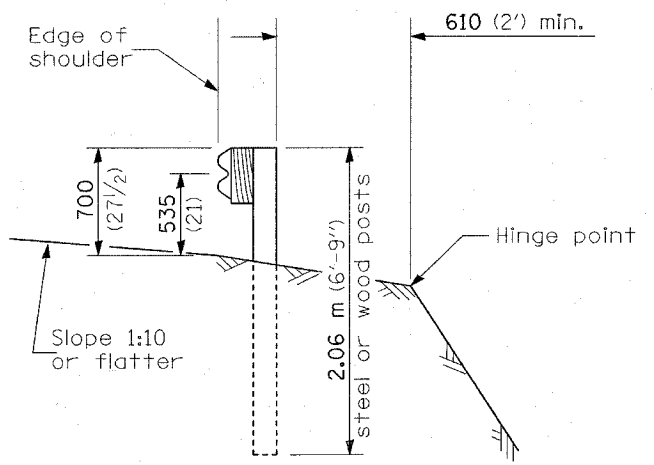

SECTION A-A

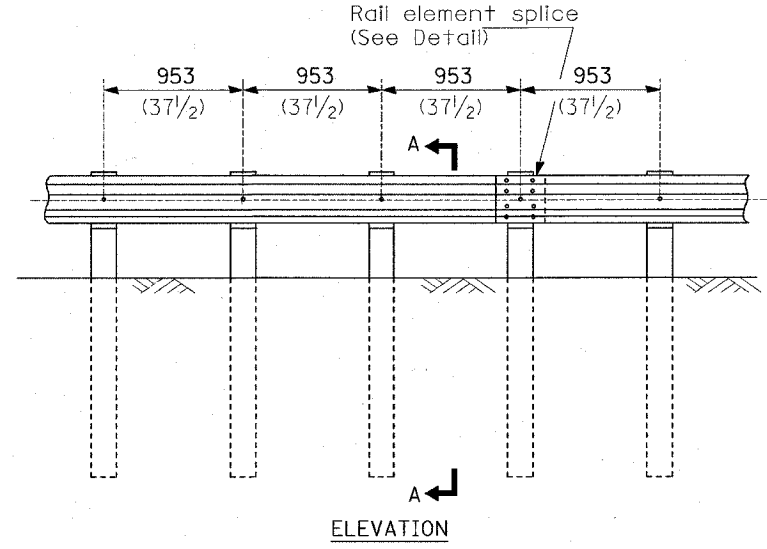

ELEVATION

TYPE B

953 (37 1/2) Closed post spacing

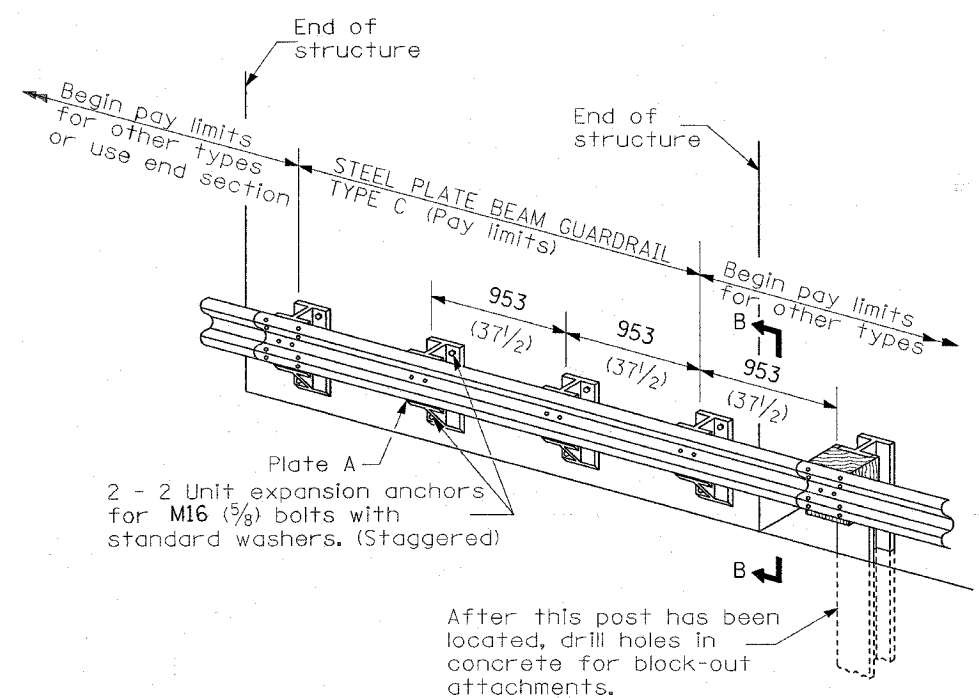

TYPE C

953 (37 1/2) Block-out spacing

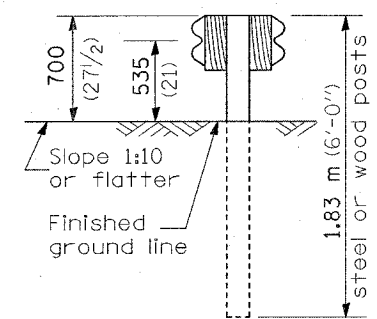

SECTION C-C

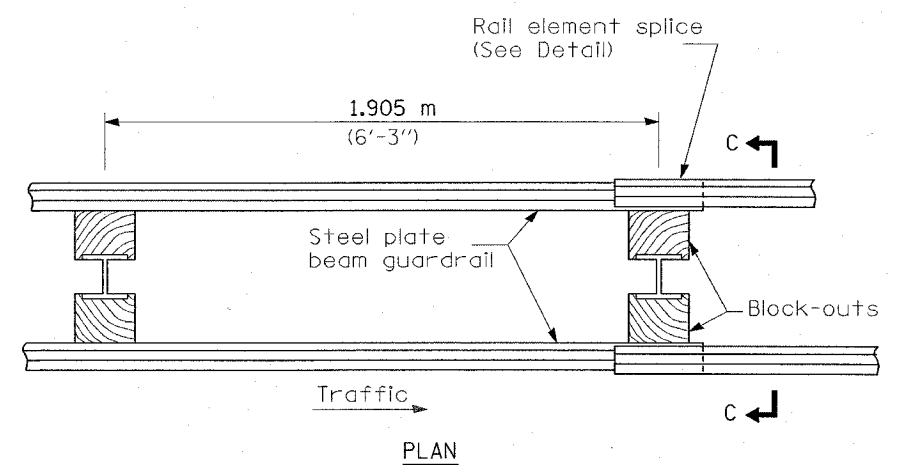

PLAN

TYPE D

Double steel plate beam guardrail
1.905 m (6'-3") typical post spacing

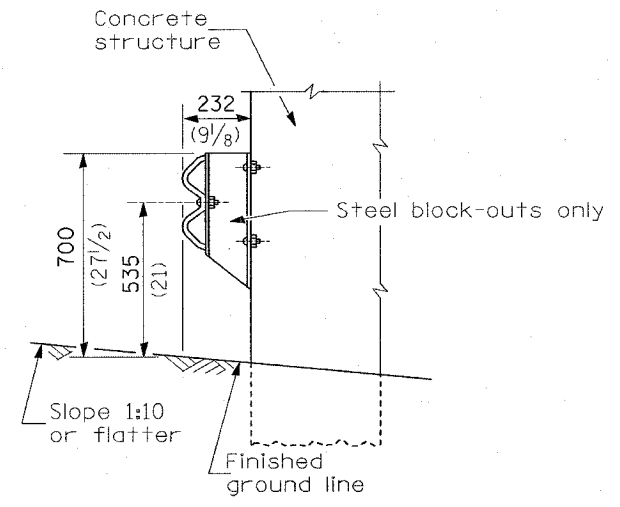

SECTION B-B

GENERAL NOTES

All slope ratios are expressed as units of vertical displacement to units of horizontal displacement (V:H).
All dimensions are in millimeters (inches) unless otherwise shown.

ILLINOIS DEPARTMENT OF TRANSPORTATION

STEEL PLATE BEAM GUARDRAIL

FAI RTE 270
SECTION 60-(2,3)I
MADISON COUNTY

CONTRACT NO. 76A20				
F.A.I. RTE.	SECTION	COUNTY	TOTAL SHEETS	SHEET NO.
64	60-(2,3)I	MADISON	32	28
STA.		TO STA.		
FED. ROAD DIST. NO.		ILLINOIS FED. AID PROJECT		

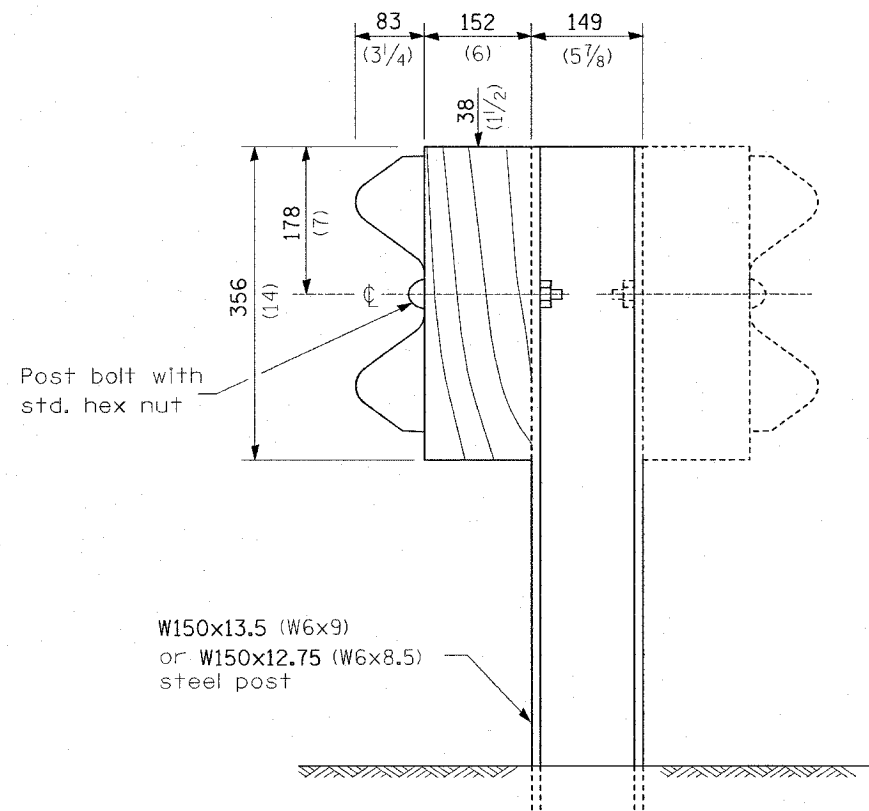

STEEL POST CONSTRUCTION

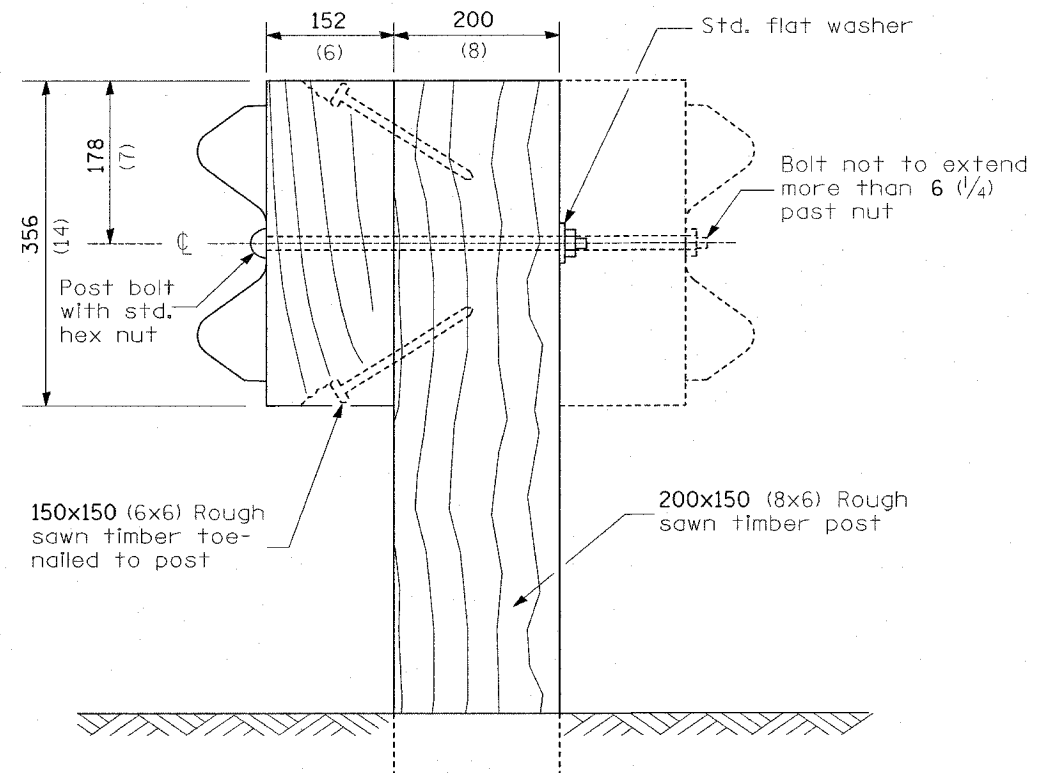

WOOD POST CONSTRUCTION

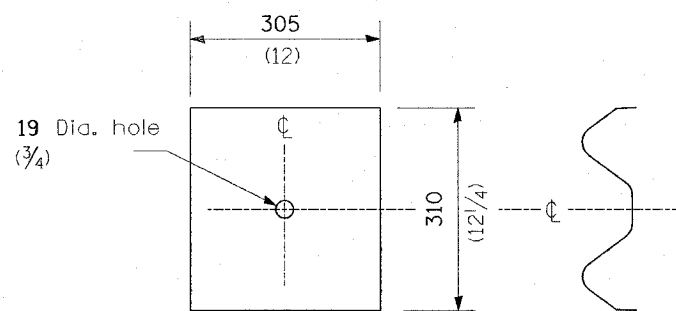

NOTE

Plate A shall be placed between rail element and block-out at non-splice mounting points only when steel block-outs are used.

PLATE A

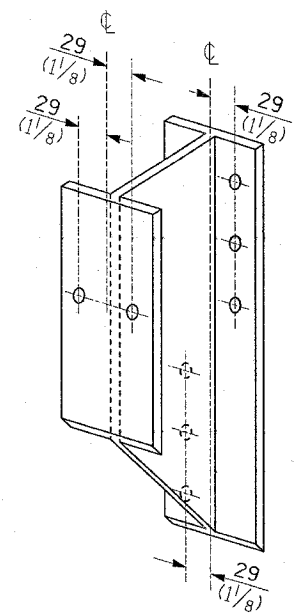

STEEL BLOCK-OUT DETAIL

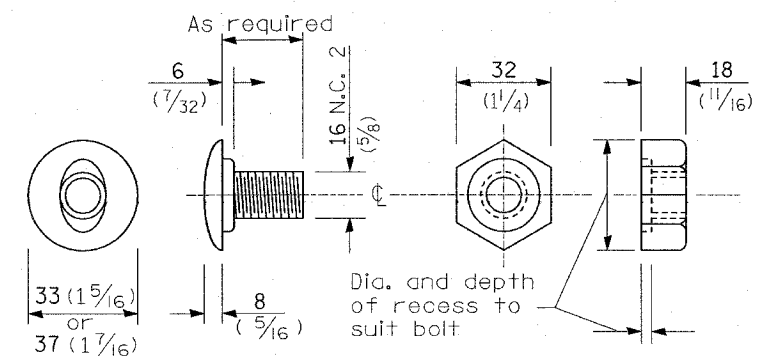

POST OR SPLICE BOLT & NUT

ILLINOIS DEPARTMENT OF TRANSPORTATION

**STEEL PLATE BEAM
GUARDRAIL**

FAI RTE 270
SECTION 60-(2,3)I
MADISON COUNTY

CONTRACT NO. 76A20				
F.A.I. RTE.	SECTION	COUNTY	TOTAL SHEETS	SHEET NO.
64	60-(2,3)I	MADISON	32	29
STA.		TO STA.		
FED. ROAD DIST. NO.		ILLINOIS FED. AID PROJECT		

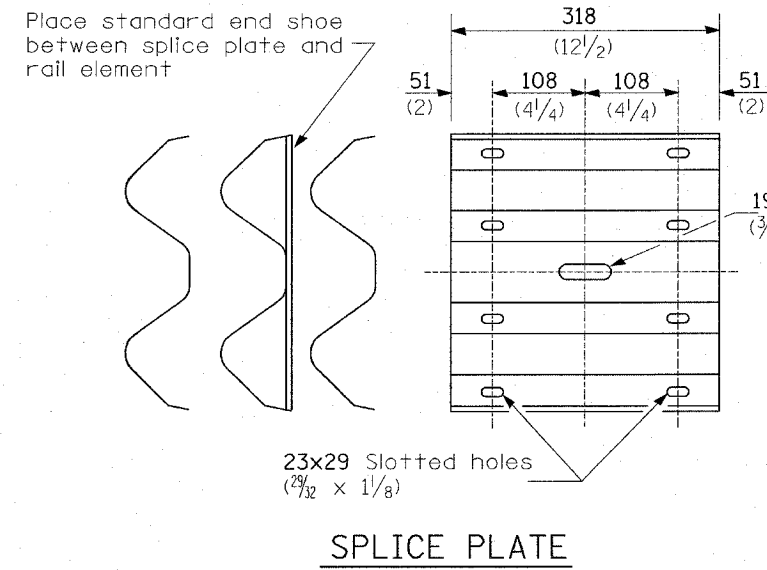

SPLICE PLATE

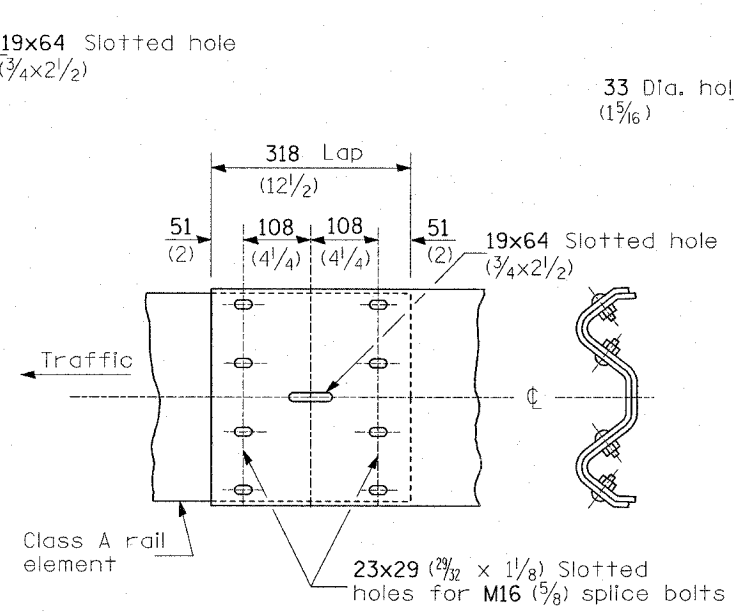

RAIL ELEMENT SPLICE

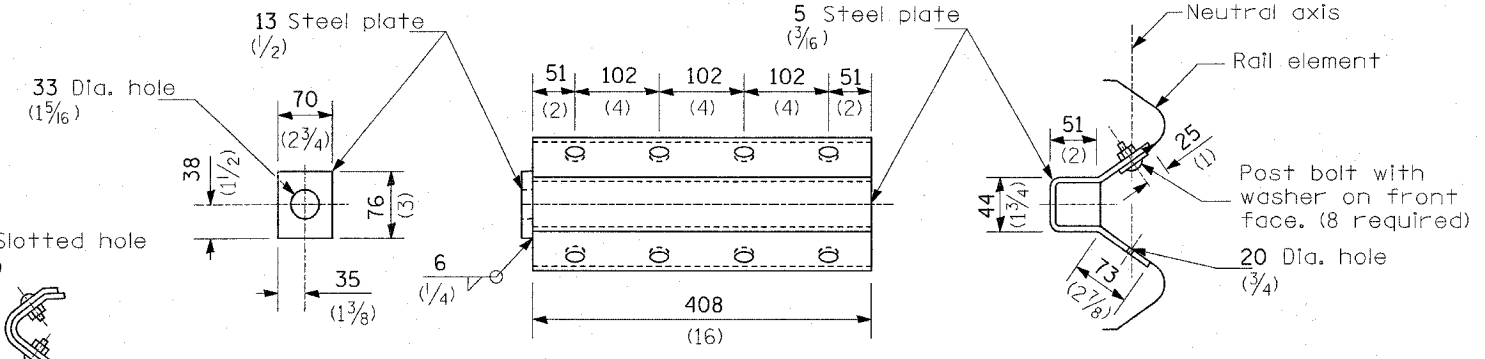

NOTE
Anchor plate T shall be used to attach cable assembly to guardrail when required on traffic barrier terminals.

ANCHOR PLATE T DETAILS

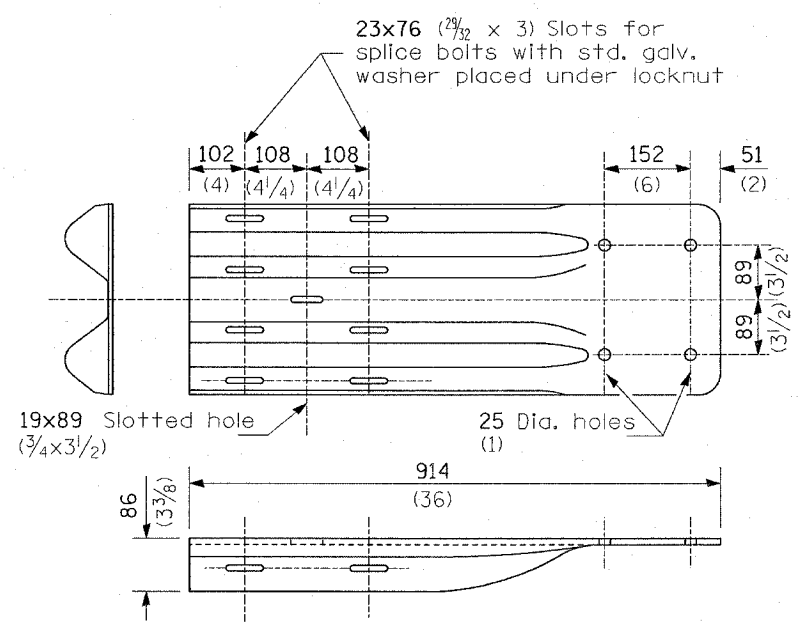
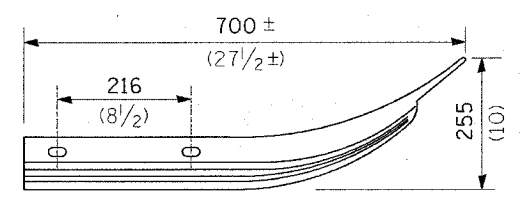

NOTE

When end shoe is attached to a bridge parapet which has an expansion joint, the bolts shall be provided with a locknut or double nut and shall be tightened only to a point that will allow guardrail movement.

The standard end shoe shall be attached to the concrete with pre-drilled or self-drilling anchor bolts. The anchor cone shall be set flush with the surface of the concrete.

Externally threaded studs protruding from the surface of the concrete will not be permitted.

END SHOE

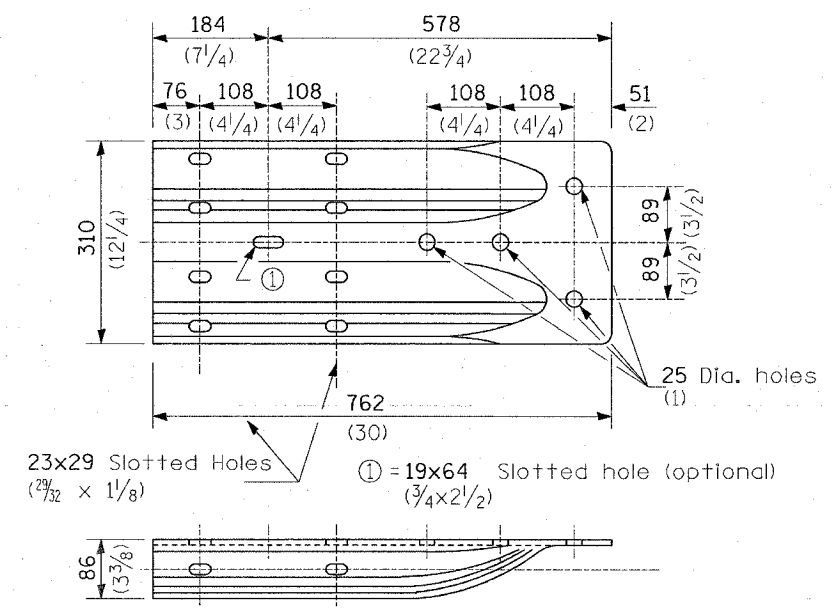

ALTERNATE END SHOE

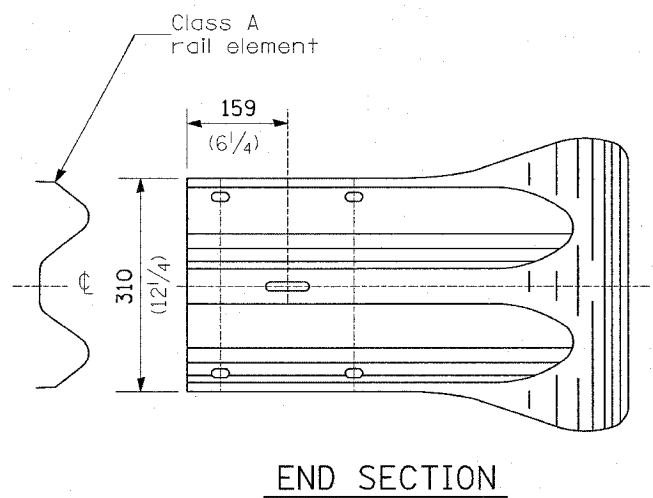

END SECTION

ILLINOIS DEPARTMENT OF TRANSPORTATION
STEEL PLATE BEAM GUARDRAIL
FAI RTE 270
SECTION 60-(2,3)I
MADISON COUNTY

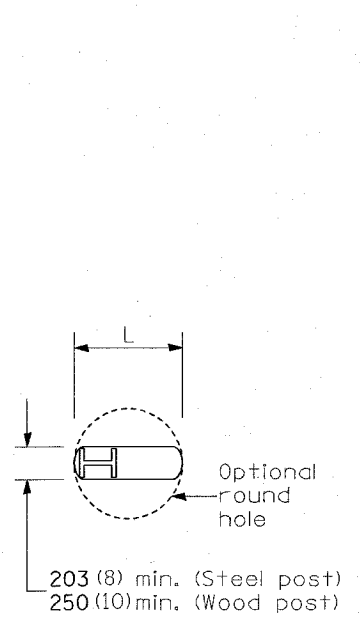

PLAN

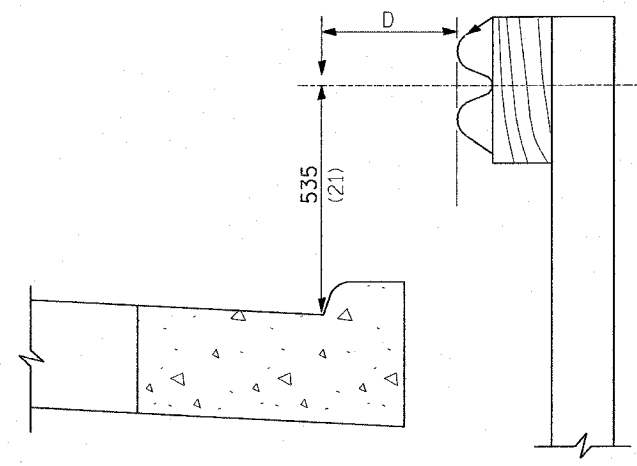

Note:
If it is necessary for D to be more than 300 (12) and less than 3.0 m (10'-0") type M-5 (M-2) curb and gutter (Std. 606001) shall be used in front of and in advance of the guardrail.

GUARDRAIL PLACED BEHIND CURB

(D = 0 desirable to 300 (12) maximum)

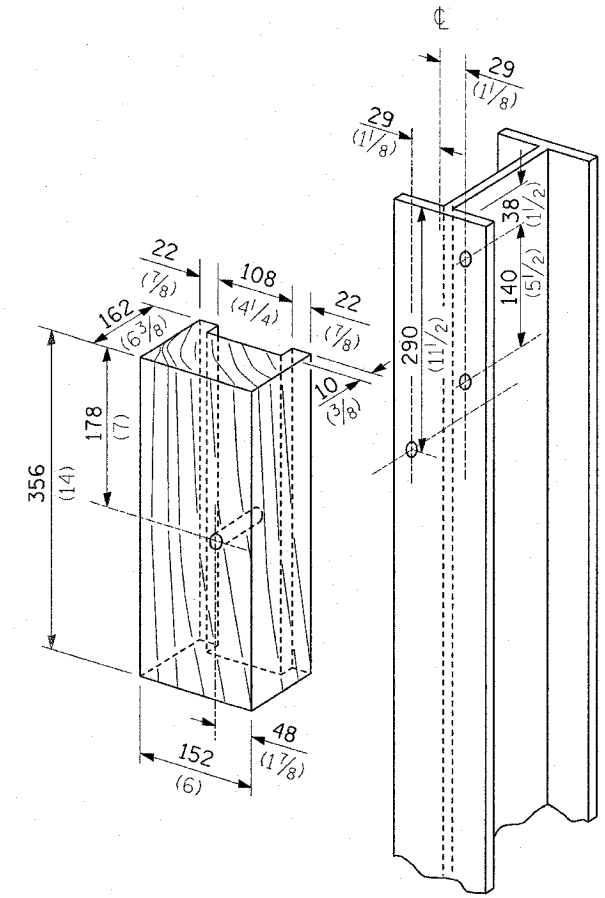

WOOD BLOCK-OUT AND STEEL POST DETAILS

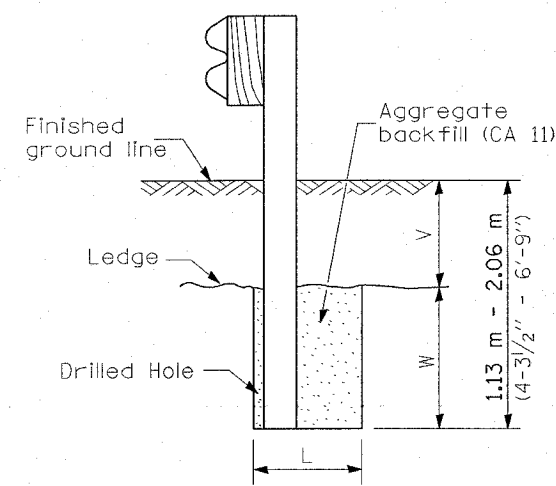

Note:
Ledge line is top of rock ledge or hard slag fill.

ELEVATION

FOOTING FOR POST WHEN IMPERVIOUS MATERIAL IS ENCOUNTERED

V	W	L	
		Steel Post	Wood Post
0 - 460 (0 - 18)	610 (24)	530 (21)	580 (23)
>460 - 825 (>18 - 41.5)	305 (12)	203 (8)	250 (10)
>825 - 1.13 m (>41.5 - 53.5)	305 - 0 (12 - 0)	203 (8)	250 (10)

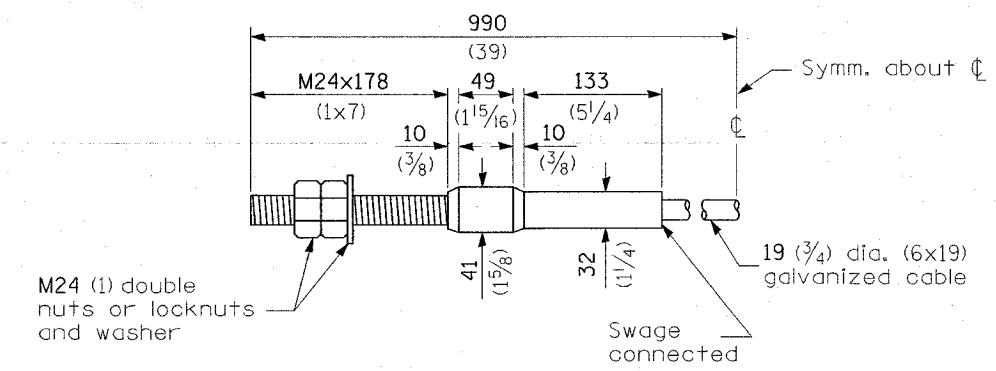

CABLE ASSEMBLY

(18,100 kg (40,000 lbs.) min. breaking strength)
Tighten to taut tension.

CONTRACT NO. 76A20				
F.A.I. RTE.	SECTION	COUNTY	TOTAL SHEETS	SHEET NO.
64	60-(2,3)I	MADISON	32	31
STA.		TO STA.		
FED. ROAD DIST. NO. ILLINOIS FED. AID PROJECT				

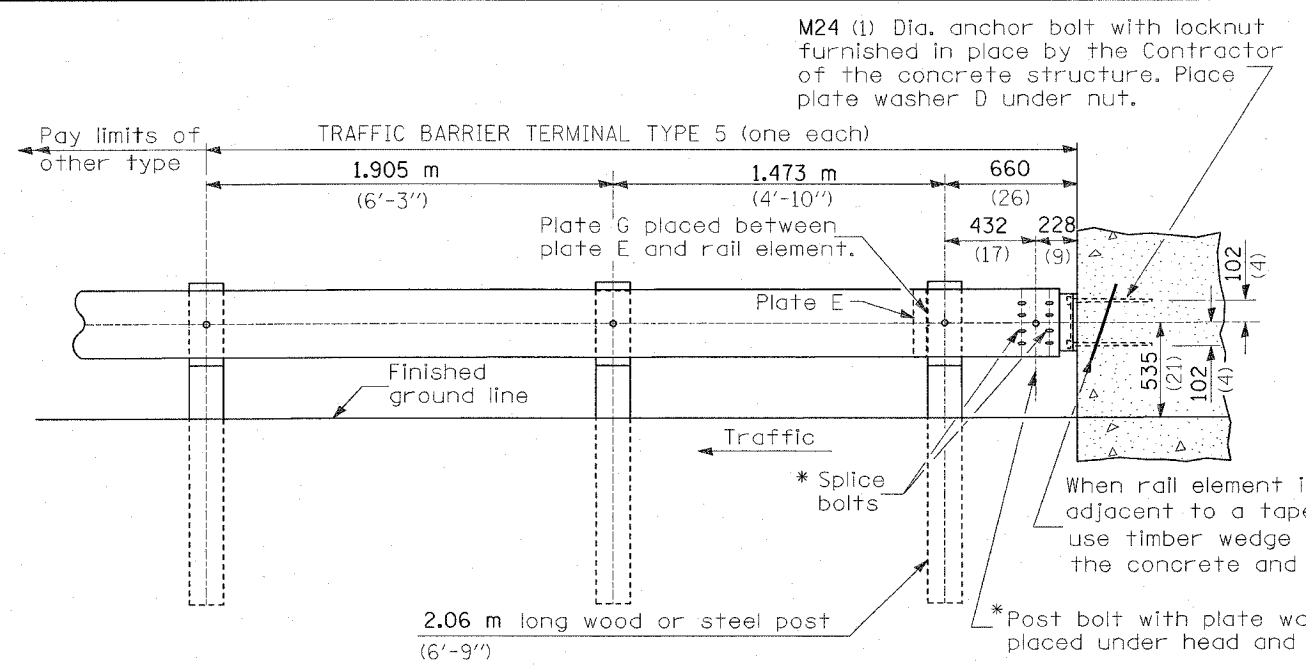

TYPE 5 - CONCRETE BRIDGE PARAPET

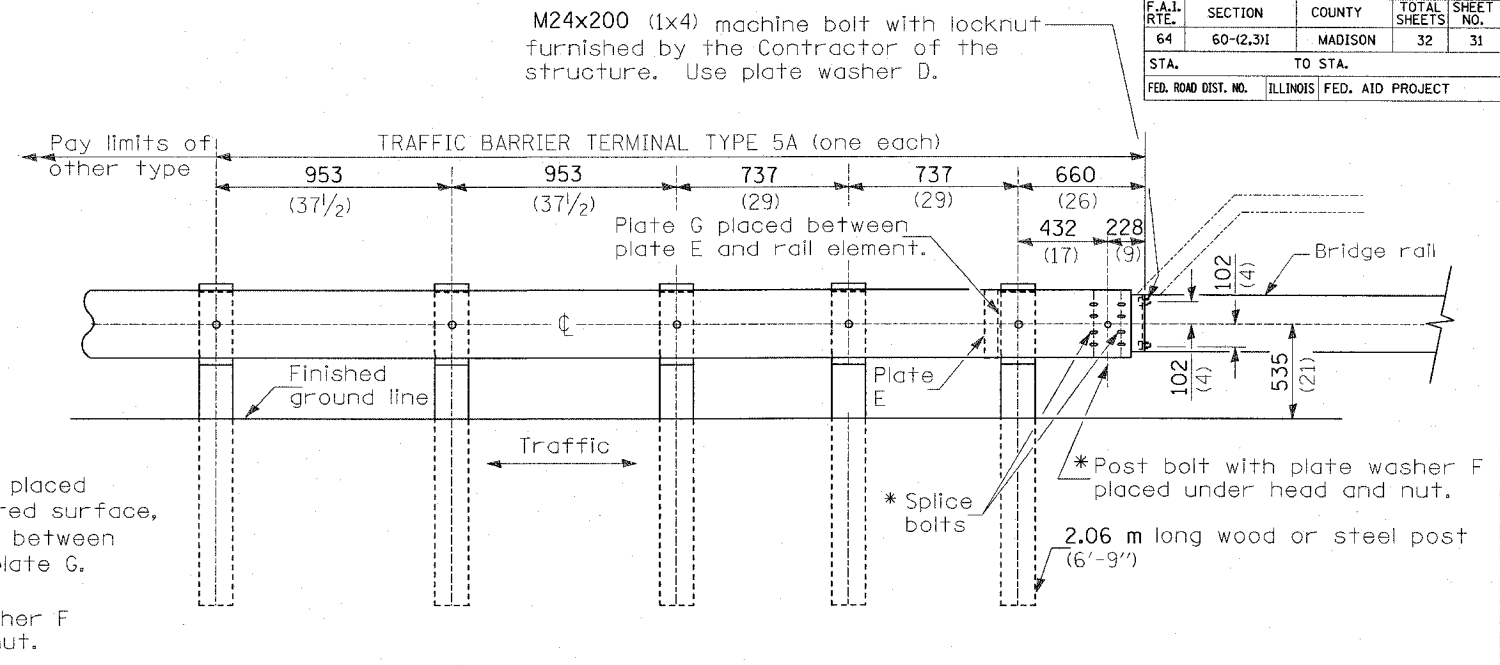

TYPE 5A - STEEL BRIDGE RAIL

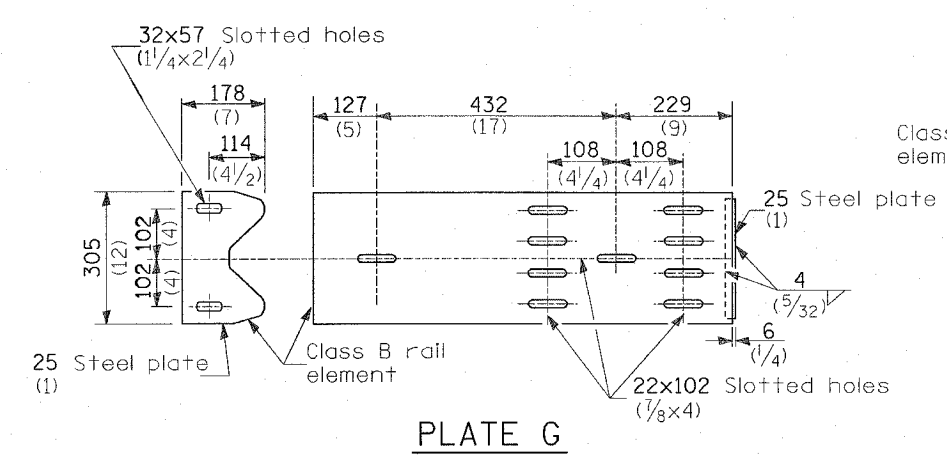

PLATE G

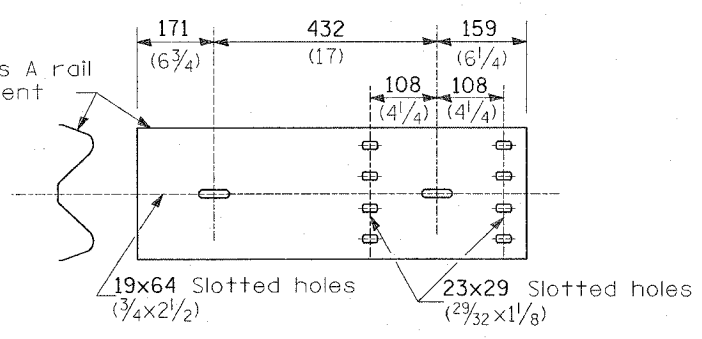
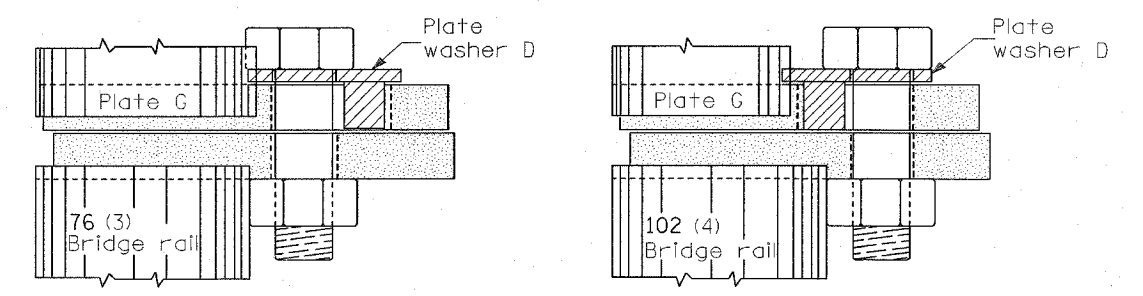

PLATE E



PLACEMENT OF PLATE WASHER D (PLAN)

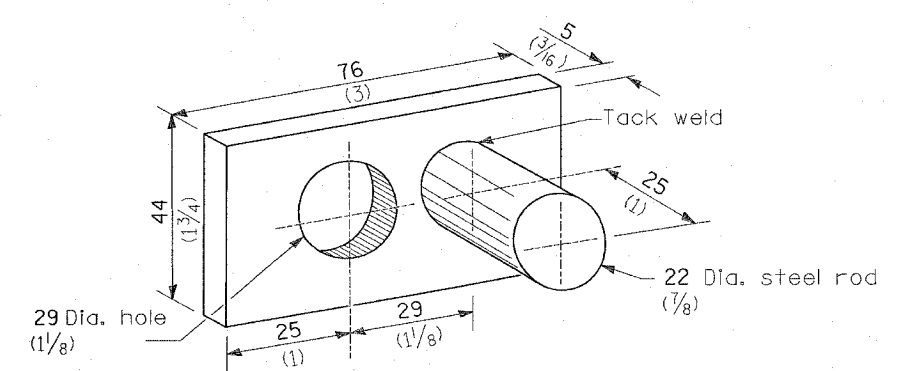
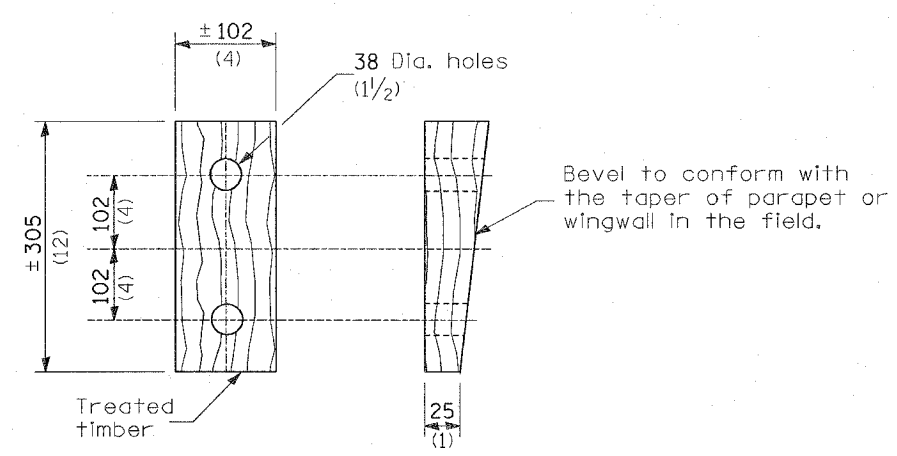

PLATE WASHER D



WEDGE M

GENERAL NOTES

- Install plate washer D so that the 25 mm (1") projection fills the remainder of the slotted holes in the 25 mm (1") end plate on plate G after the M24 (1") dia. bolts are in place.
- * Bolts shall be provided with locknut or double nut and shall be tightened only to a point that will allow plate G to be free to move when an expansion joint exists below the connector.
- See Standard 630001 for details of guardrail not shown.
- All dimensions are in millimeters (inches) unless otherwise shown.

ILLINOIS DEPARTMENT OF TRANSPORTATION
**TRAFFIC BARRIER TERMINAL
 TYPE 5 & 5A**
 FAI RTE 270
 SECTION 60-(2,3)I
 MADISON COUNTY

F.A.I. RTE.	SECTION	COUNTY	TOTAL SHEETS	SHEET NO.
270	60-(2,3)I	MADISON	32	32
STA.		TO STA.		
FED. ROAD DIST. NO. ILLINOIS FED. AID PROJECT				

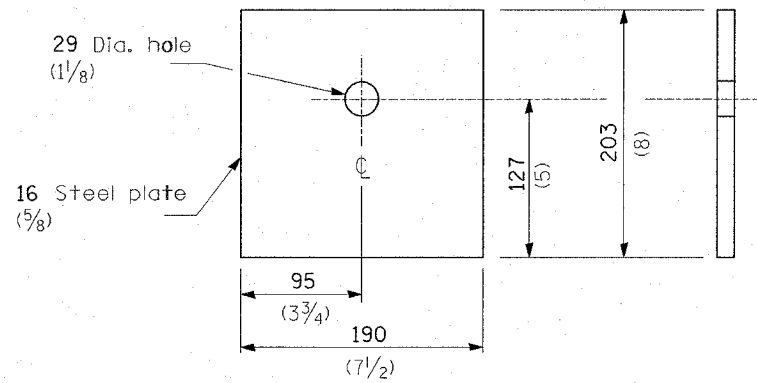

BEARING PLATE K

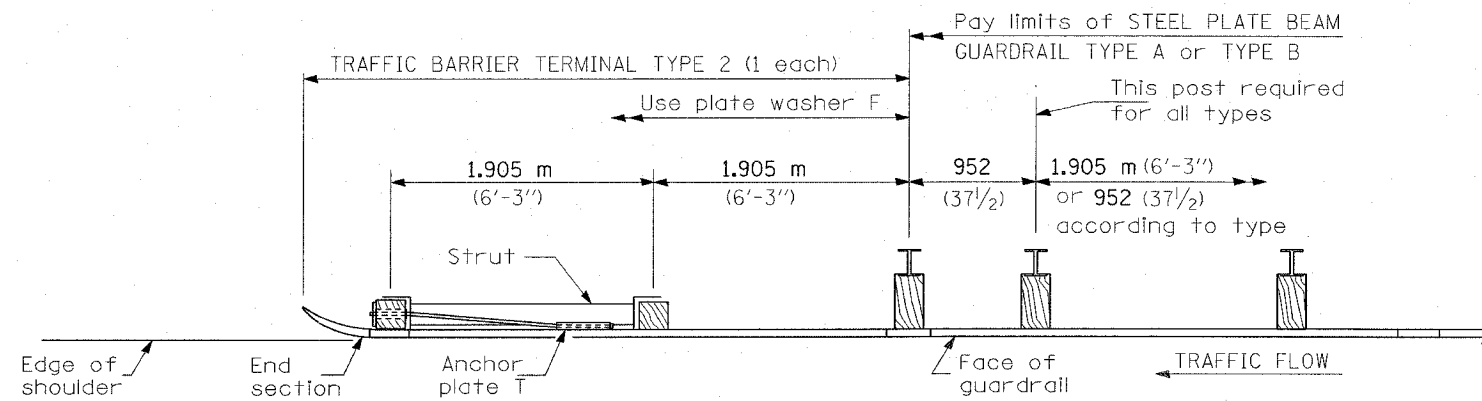

PLAN

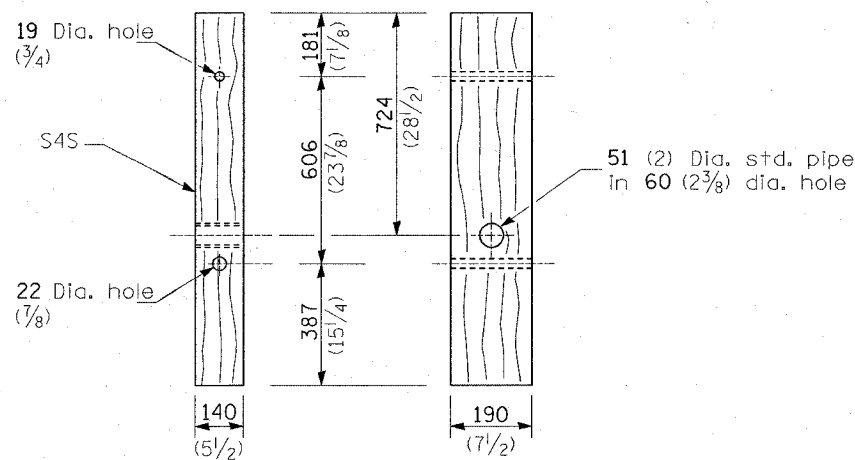

WOOD POST

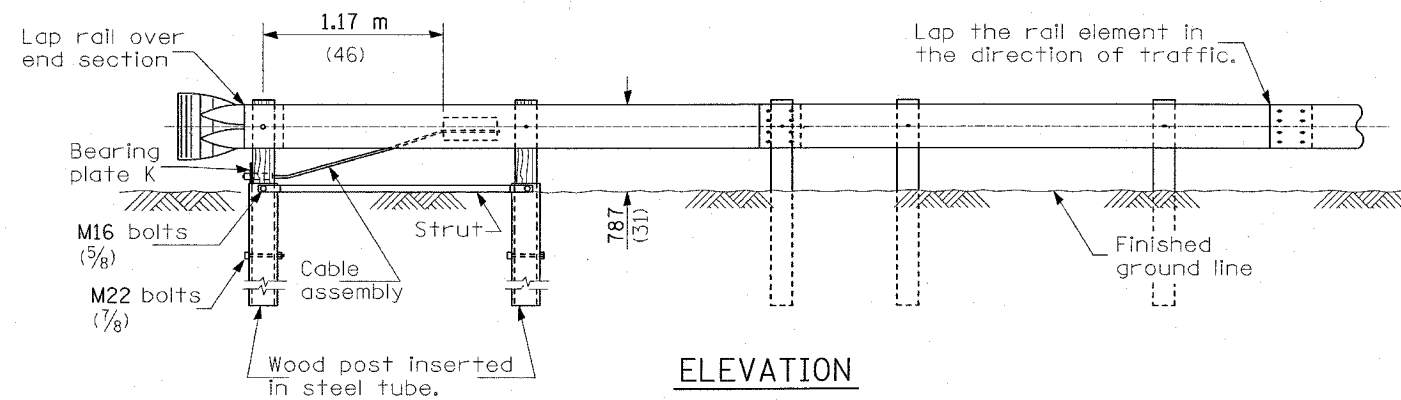

ELEVATION

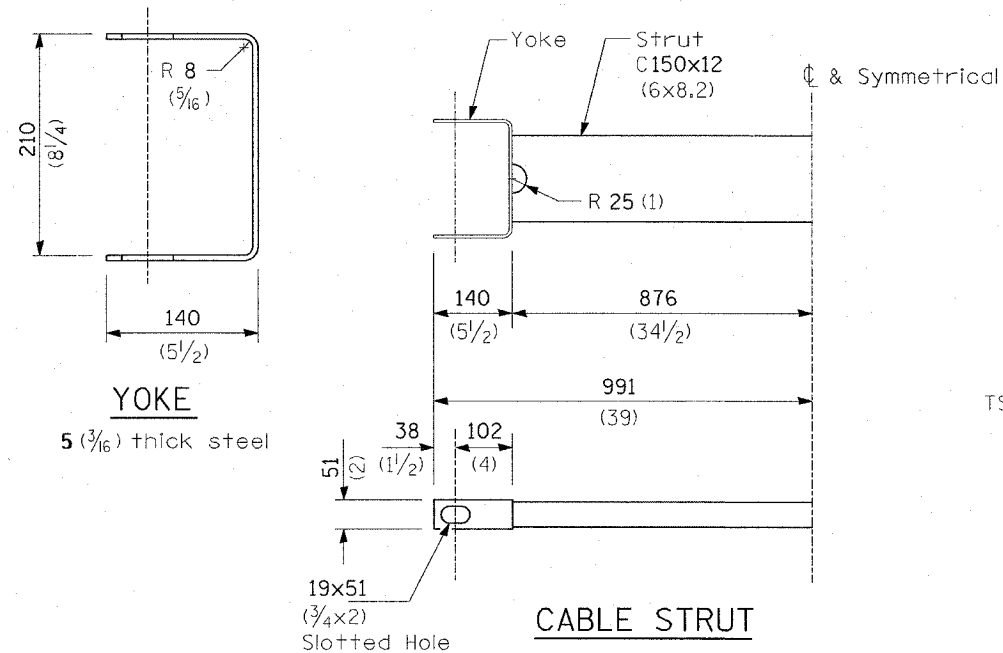

YOKE

CABLE STRUT

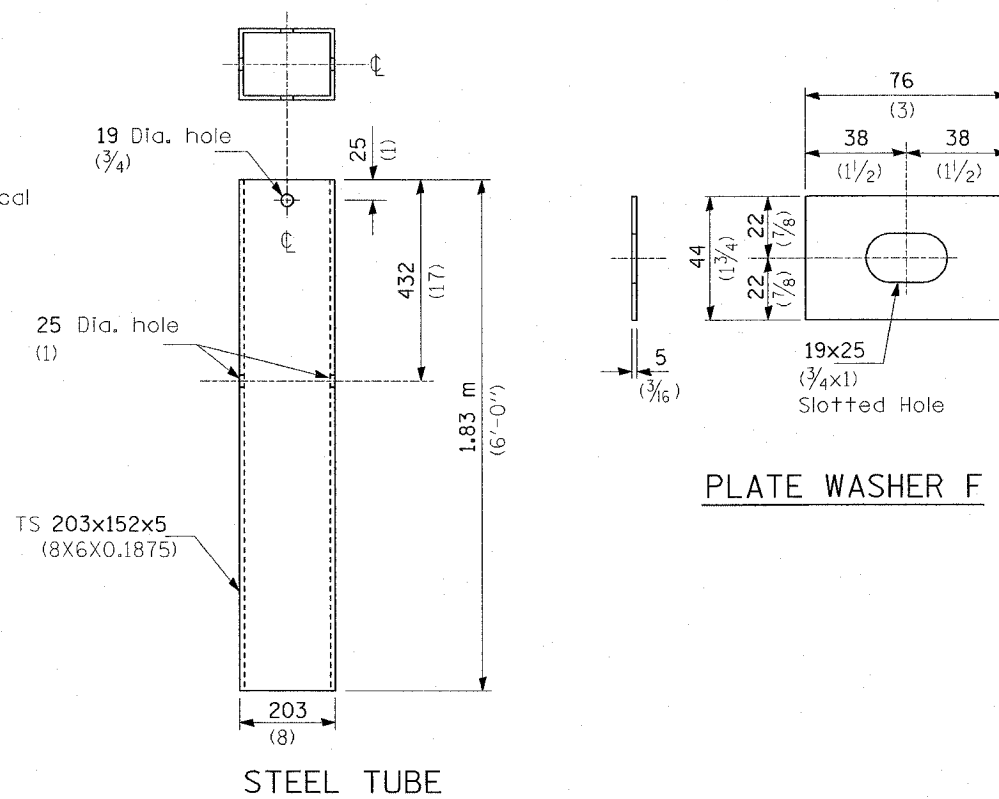

STEEL TUBE

PLATE WASHER F

GENERAL NOTES

See Standard 630001 for details of guardrail not shown.

The bearing plate K shall be held in position by (2) two eight penny nails driven into the post and bent over the top of the plate.

All dimensions are in millimeters (inches) unless otherwise shown.

REVISIONS	
NAME	DATE

ILLINOIS DEPARTMENT OF TRANSPORTATION
TRAFFIC BARRIER TERMINAL, TYPE 2
 FAI RTE 270
 SECTION 60-(2,3)I
 MADISON COUNTY

DRAWN BY:

PLOT DATE: *DATE-TIME*

DATE	
PLAN	
NO.	
DATE	
NO.	
DATE	
NO.	
DATE	
NO.	