

STATE OF ILLINOIS
DEPARTMENT OF TRANSPORTATION

F.A.P. RTE.	SECTION	COUNTY	TOTAL SHEETS	SHEET NO.
95	7BR-2	EFFINGHAM	409	368
FED. ROAD DIST. NO. 7		ILLINOIS	FED. AID PROJECT	

SHEET NO. 6
SHEETS 8

CONTRACT NO. 94356

* Granular or solid flux filled headed studs conforming to Article 1006.32 of the Std. Specs., automatically end welded.
** When joint is fixed, dimension is set at 1 1/2".

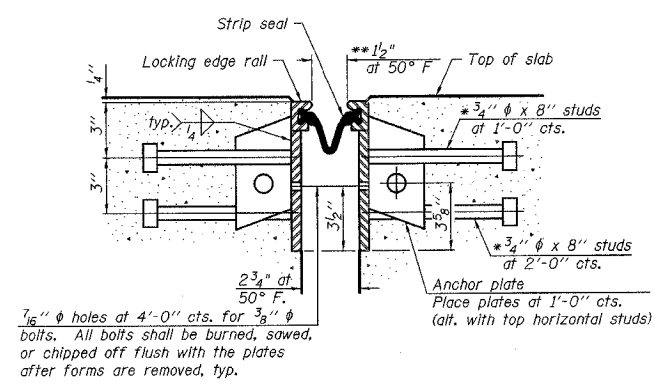
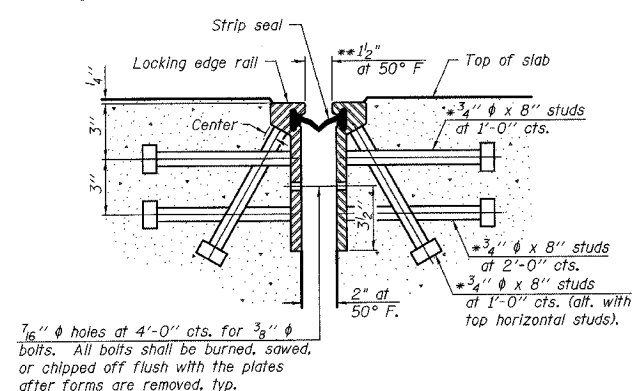

Notes:
The strip seal shall be made continuous and shall have a minimum thickness of 1/4". The configuration of the strip seal shall match the configuration of the Locking Edge Rails. Open or "webbed" strip seal gland configurations are not permitted. The gland shall be sized for a maximum rated movement of 4 inches.
The height and thickness of the Locking Edge Rails shown are minimum dimensions. The actual configuration of the Locking Edge Rails and matching strip seal may vary from manufacturer to manufacturer. Flanged edge rails will not be allowed. Locking Edge Rails may be spliced at slope discontinuities and stage construction joints.
The manufacturer's recommended installation methods shall be followed.
The joint opening and deck dimensions detailed on the superstructure are based on a rolled rail expansion joint. If the Contractor elects to use the welded rail expansion joint, the opening and deck dimensions shall be modified according to the dimensions detailed on this sheet. Required modifications shall be made at no additional cost to the State.
All steel components shall be galvanized after fabrication according to Article 520.03 of the Standard Specifications.

SECTION THRU ROLLED RAIL JOINT

SECTION THRU WELDED RAIL JOINT

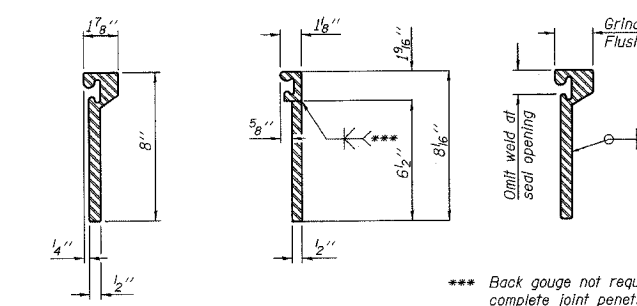

ROLLED (EXTRUDED) RAIL WELDED RAIL

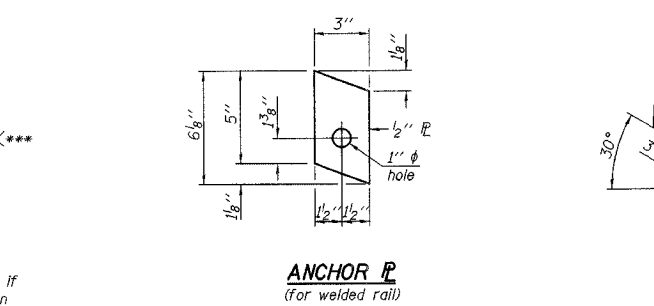

ANCHOR PLATE (for welded rail)

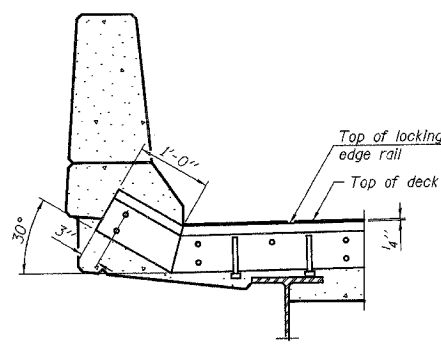

AT PARAPET

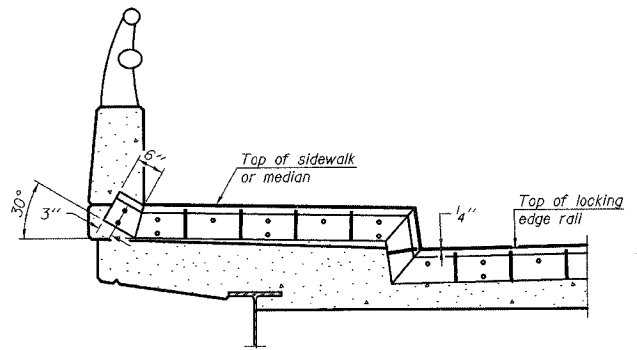

AT SIDEWALK OR MEDIAN

*** Back gouge not required if complete joint penetration is verified by mock-up.
LOCKING EDGE RAIL SPLICE
The inside of the locking edge rail groove shall be free of weld residue.

LOCKING EDGE RAILS

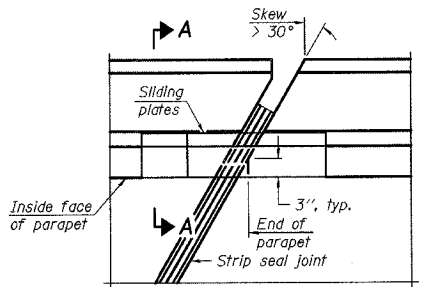

PLAN

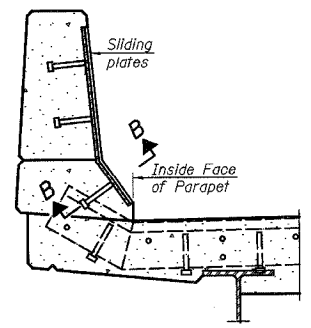

SECTION A-A

POINT BLOCK DETAILS (for skews > 30°)

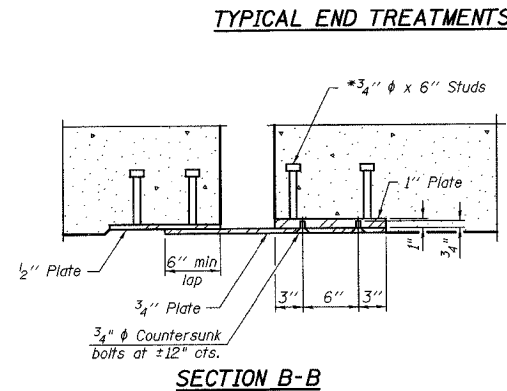

SECTION B-B

BILL OF MATERIAL

Item	Unit	Total
Preformed Joint Strip Seal	Foot	90

BRIDGE JOINT SYSTEM - EXPANSION
(ALTERNATE - STRIP SEAL)
SHEET 2 OF 2
IL ROUTE 33 OVER
LITTLE SALT CREEK
F.A.P. 95 - SECTION 7BR-2
EFFINGHAM COUNTY
SN 025-0082

EJ-SSJ

11-1-06