

**NORTH MAIN STREET**  
STA. 50+00 TO STA. 57+23.89

• PAID FOR AS HOT-MIX ASPHALT PAVEMENT (FULL DEPTH), 8 1/4"

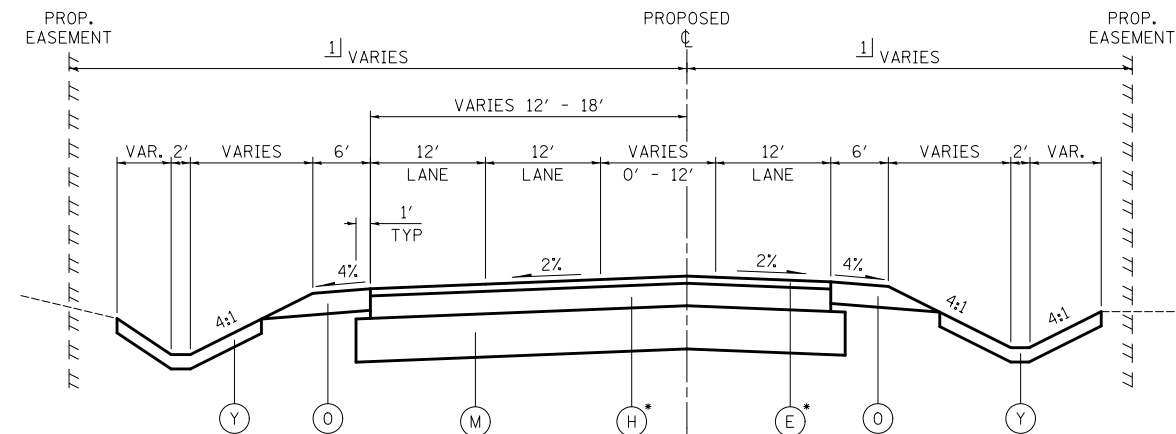

**QUARRY ACCESS**  
STA. 60+00 TO STA. 67+86.48

• PAID FOR AS HOT-MIX ASPHALT PAVEMENT (FULL DEPTH), 8 1/4"

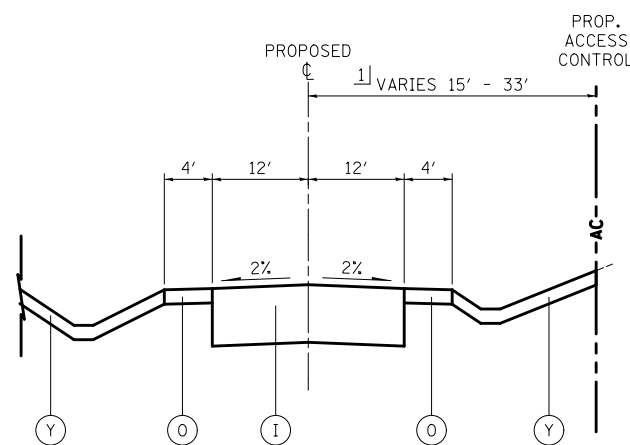

**ACCESS DRIVE**  
STA. 60+00 TO STA. 73+29.12

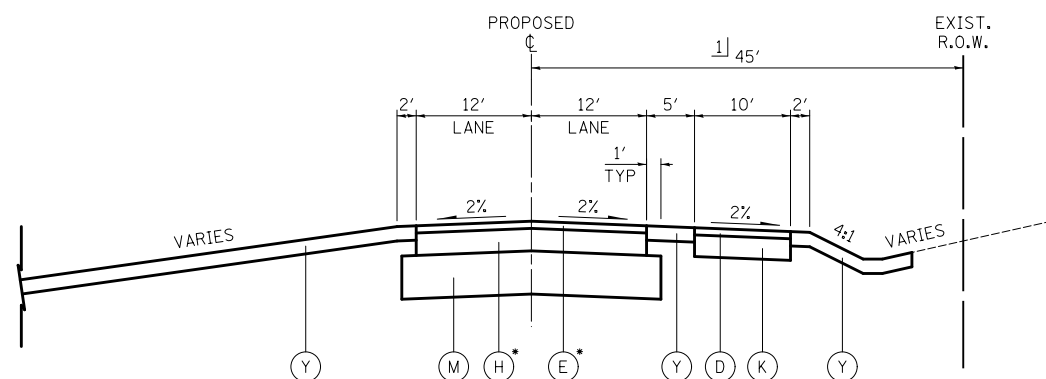

**FRONTAGE ROAD**  
STA. 0+00 TO STA. 5+41.25

• PAID FOR AS HOT-MIX ASPHALT PAVEMENT (FULL DEPTH), 8 1/4"

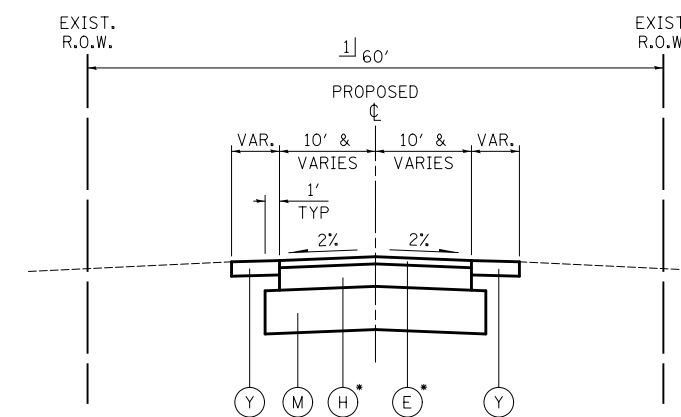

**ELMWOOD COURT  
OAKWOOD COURT  
LINDEN AVENUE**

• PAID FOR AS HOT-MIX ASPHALT PAVEMENT (FULL DEPTH), 8 1/4"

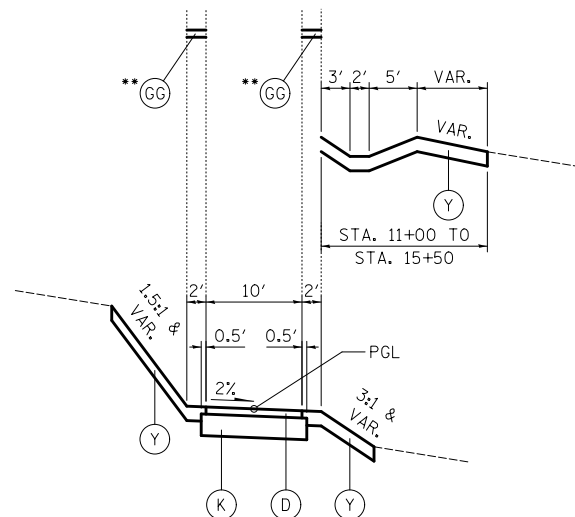

• STA. 15+25 TO STA. 17+75  
SEE STRUCTURAL PLANS AND LANDSCAPE PLANS FOR MORE DETAILS

**MCD PRAIRIE PATH**  
STA. 0+00 TO STA. 26+13.88

**LEGEND**

- (A) PORTLAND CEMENT CONCRETE PAVEMENT, 9 3/4" (JOINTED)
- (B) HOT-MIX ASPHALT BINDER COURSE, IL-19.0, N90, 10" (4 LIFTS)
- (C) POLYMERIZED HOT-MIX ASPHALT SURFACE COURSE, MIX "F", N90, 2"
- (D) HOT-MIX ASPHALT SURFACE COURSE, MIX "D", N50, 2"
- (E) HOT-MIX ASPHALT SURFACE COURSE, MIX "D", N70, 2"
- (F) POLYMERIZED HOT-MIX ASPHALT SURFACE COURSE, MIX "F", N90, 2 3/4"
- (G) POLYMERIZED HOT-MIX ASPHALT BINDER COURSE, IL-19.0, N90, 2 1/4"
- (H) HOT-MIX ASPHALT BINDER COURSE, IL-19.0, N70, 6 1/4" (2 LIFTS)
- (I) AGGREGATE SUBGRADE IMPROVEMENT, 24"
- (J) SUB-BASE GRANULAR MATERIAL, TYPE B
- (K) SUB-BASE GRANULAR MATERIAL, TYPE B, 6"
- (L) STABILIZED SUB-BASE, HOT-MIX ASPHALT, 4 1/2"
- (M) AGGREGATE SUBGRADE IMPROVEMENT, 12"
- (N) PORTLAND CEMENT CONCRETE SHOULDERS, 9 3/4"
- (O) AGGREGATE SHOULDER TYPE B, 6"
- (P) HOT-MIX ASPHALT SHOULDERS, 6" (2 LIFTS)
- (Q) COMBINATION CONCRETE CURB AND GUTTER, TYPE B-6.24
- (R) COMBINATION CONCRETE CURB AND GUTTER, TYPE B-6.06
- (S) COMBINATION CONCRETE CURB AND GUTTER, TYPE B-6.12
- (T) CONCRETE MEDIAN SURFACE, 4"
- (U) CONCRETE MEDIAN, TYPE SB-6.24
- (V) CONCRETE MEDIAN, TYPE SB-6.24 (MODIFIED)
- (W) SELECT BACKFILL
- (X) PORTLAND CEMENT CONCRETE SIDEWALK, 5" SPECIAL
- (Y) TOPSOIL FURNISH AND PLACE, 4" SEEDING, FERTILIZER AND EROSION CONTROL MAT
- (Z) PROPOSED RETAINING WALL
- (AA) CONCRETE BARRIER WALL (SPECIAL)
- (BB) PROPOSED NOISE WALL
- (CC) STEEL PLATE BEAM GUARDRAIL, TYPE A
- (DD) BRICK PAVERS
- (EE) EXISTING P.C.C. SIDEWALK
- (FF) LONGITUDINAL CONSTRUCTION JOINT - #6 STEEL TIE BAR, 24" C-C, COST INCLUDED IN COMBINATION CONCRETE CURB AND GUTTER PAY ITEM
- (GG) LIMESTONE SCREENINGS, 2"
- (HH) COMBINATION CONCRETE CURB AND GUTTER, TYPE B-6.18
- (II) TOPSOIL FURNISH AND PLACE, 4" SEEDING AND FERTILIZER
- (JU) LONGITUDINAL CONSTRUCTION JOINT - #6 STEEL TIE BAR, COST INCLUDED IN PCC PAVEMENT, 9 3/4" (JOINTED)
- (KK) LONGITUDINAL SAWED JOINT - #6 EPOXY COATED STEEL TIE BAR, 30" C-C, COST INCLUDED IN PCC PAVEMENT, 9 3/4" (JOINTED)
- (1) EXISTING P.C. CONCRETE PAVEMENT, 5" AND VARIES
- (2) EXISTING HOT-MIX ASPHALT SURFACE COURSE, THICKNESS VARIES .75" TO 4"
- (4) EXISTING HOT-MIX ASPHALT BASE COURSE, THICKNESS VARIES 5" TO 13.5"
- (6) EXISTING SUB-BASE GRANULAR MATERIAL, THICKNESS VARIES 4" TO 16"
- (10) EXISTING COMBINATION CURB AND GUTTER, TYPE B-6.24
- (Δ) COST INCLUDED IN HOT-MIX ASPHALT PAVEMENT (FULL-DEPTH), 14.25"
- (ΔΔ) COST INCLUDED IN HOT-MIX ASPHALT PAVEMENT (FULL-DEPTH), 8.25"

**SHEET NOTES**

1] SEE SHEETS 410 - 457 FOR RIGHT OF WAY DIMENSIONS.

FILE NAME = ...\\D160F72-sht-typical-15.dgn	USER NAME = ctb	DESIGNED - GAB	REVISED -
		DRAWN - ARA	REVISED -
	PLOT SCALE = 2.0000' / in.	CHECKED - GAB	REVISED -
	PLOT DATE = 5/2/2012	DATE - 5/3/2012	REVISED -

**STATE OF ILLINOIS  
DEPARTMENT OF TRANSPORTATION**

**PROPOSED TYPICAL SECTIONS**

SCALE: N.T.S. SHEET NO. 15 OF 15 SHEETS STA. TO STA.

O.R. RTE.	SECTION	COUNTY	TOTAL SHEETS	SHEET NO.
0003	18A-2	MCHENRY	825	38
<b>CONTRACT NO. 60F72</b>				
FED. ROAD DIST. NO. 1 ILLINOIS FED. AID PROJECT				