

ELEVATION E

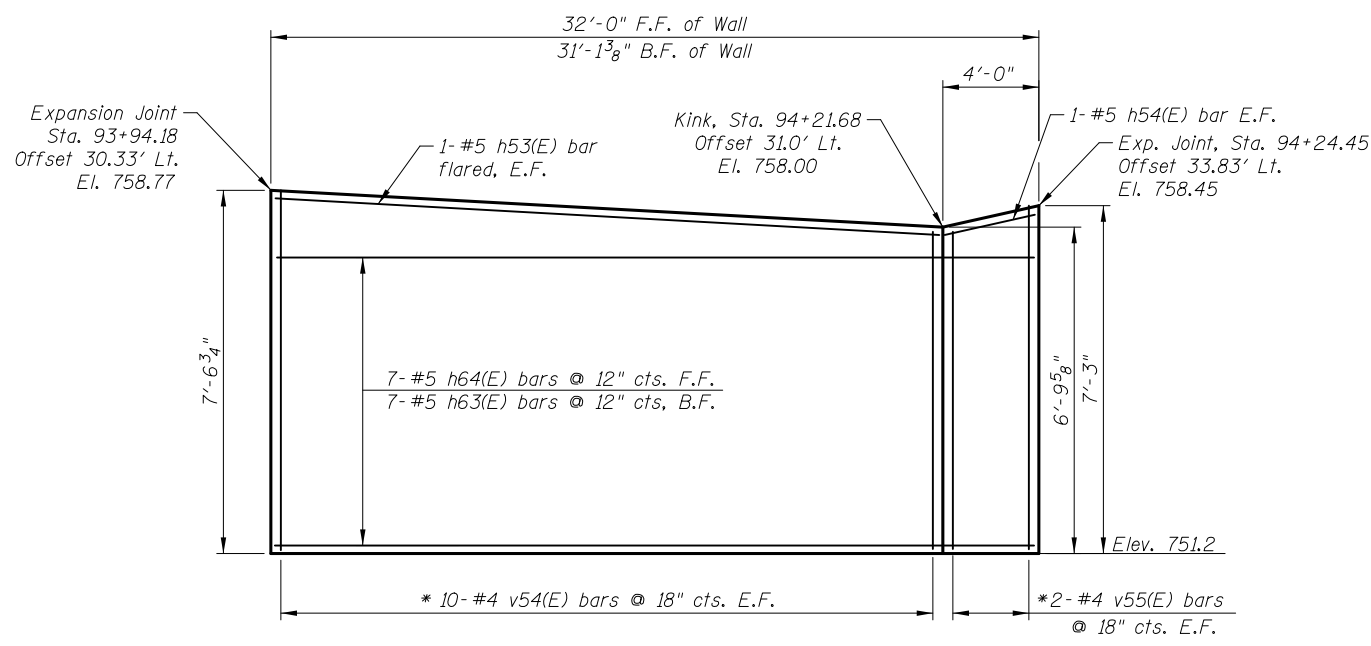

ELEVATION F

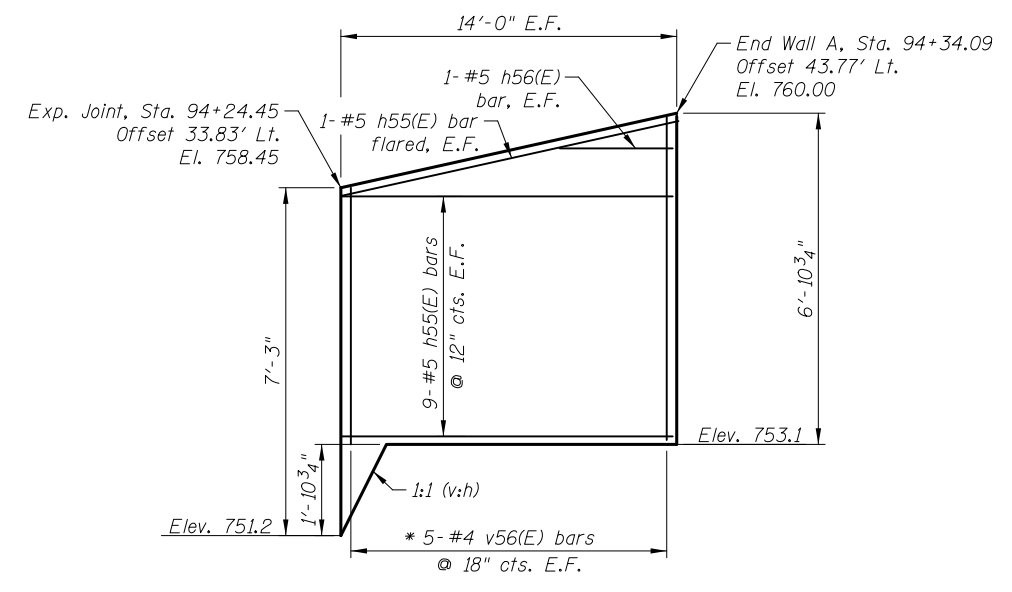

ELEVATION G

Notes:
 * See Field Cutting Diagram on sheet WA7.
 Stations and offsets are taken at front face of wall.

5/2/2012 4:22:19 PM I:\2154\cad\sheet\Roadway\20-Structures & Walls\06-Wall A\0562507-60F72-05-AND.dgn

 450 E Devon Ave, Suite 300
 Itasca, Illinois 60143
 Tel: 630.773.3900 Fax: 630.773.3975
 www.civiltechinc.com

DRAWN	-	M. LANGE
DESIGNED	-	M. LANGE
CHECKED	-	G. HATLESTAD
DATE	-	5/3/2012

STATE OF ILLINOIS
DEPARTMENT OF TRANSPORTATION

RETAINING WALL III
WALL A; IL RTE 31
STRUCTURE NO. 056-2507
 SHEET NO. WA5 OF WA9 SHEETS

O.R. RTE.	SECTION	COUNTY	TOTAL SHEETS	SHEET NO.
0003	18A-2	MCHENRY	825	589
CONTRACT NO. 60F72				
ILLINOIS FED. AID PROJECT				