

**EXISTING ISLAND REMOVAL ITEMS:**  
 CONCRETE CURB & GUTTER REMOVAL = 76.0 FT  
 CONCRETE MEDIAN REMOVAL = 263.5 SQ FT  
 PAVEMENT REMOVAL (INCLUDES NECESSARY SAWCUTS) = 4.9 SQ YD

**PROPOSED ISLAND ITEMS:**  
 COMBINATION CONCRETE CURB & GUTTER, TYPE M 6.24 = 27.3 FT  
 COMBINATION CONCRETE CURB & GUTTER, TYPE M 6.06 = 49.4 FT  
 CONCRETE MEDIAN SURFACE, 4" = 250.0 SQ FT

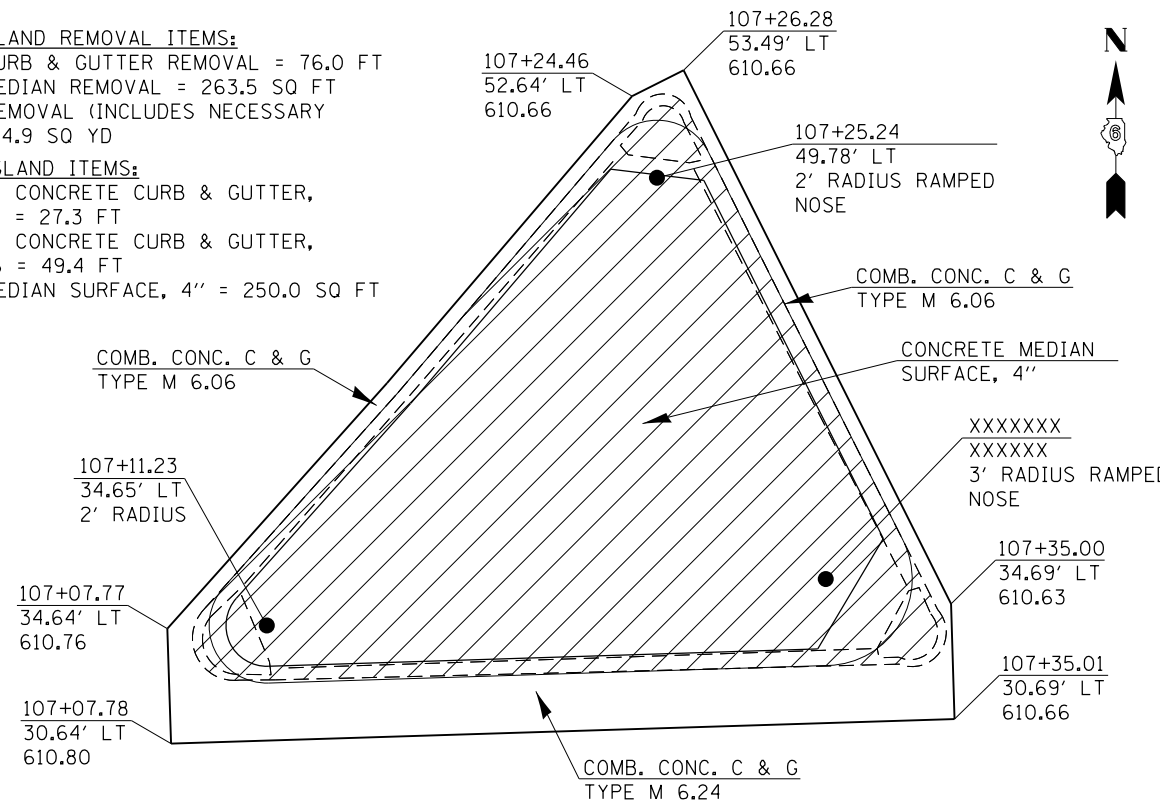

**EXISTING ISLAND REMOVAL ITEMS:**  
 CONCRETE CURB & GUTTER REMOVAL = 58.0 FT  
 CONCRETE MEDIAN REMOVAL = 175.7 SQ FT  
 PAVEMENT REMOVAL (INCLUDES NECESSARY SAWCUTS) = 7.3 SQ YD

**PROPOSED ISLAND ITEMS:**  
 COMBINATION CONCRETE CURB & GUTTER, TYPE M 6.24 = 18.2 FT  
 COMBINATION CONCRETE CURB & GUTTER, TYPE M 6.06 = 42.3 FT  
 CONCRETE MEDIAN SURFACE, 4" = 156.6 SQ FT  
 HMA BASE COURSE, 12" = 4.8 SQ YD  
 SUB-BASE GRANULAR MATERIAL TYPE B, 4" = 4.8 SQ YD

**EXISTING ISLAND REMOVAL ITEMS:**  
 CONCRETE CURB & GUTTER REMOVAL = 67.0 FT  
 CONCRETE MEDIAN REMOVAL = 186.0 SQ FT  
 PAVEMENT REMOVAL (INCLUDES NECESSARY SAWCUTS) = 7.1 SQ YD

**PROPOSED ISLAND ITEMS:**  
 COMBINATION CONCRETE CURB & GUTTER, TYPE M 6.24 = 25.0 FT  
 COMBINATION CONCRETE CURB & GUTTER, TYPE M 6.06 = 43.6 FT  
 CONCRETE MEDIAN SURFACE, 4" = 189.5 SQ FT

**N.B. I-55 EXIT RAMP / IL 104 ISLAND  
 (STA. 107+20)**

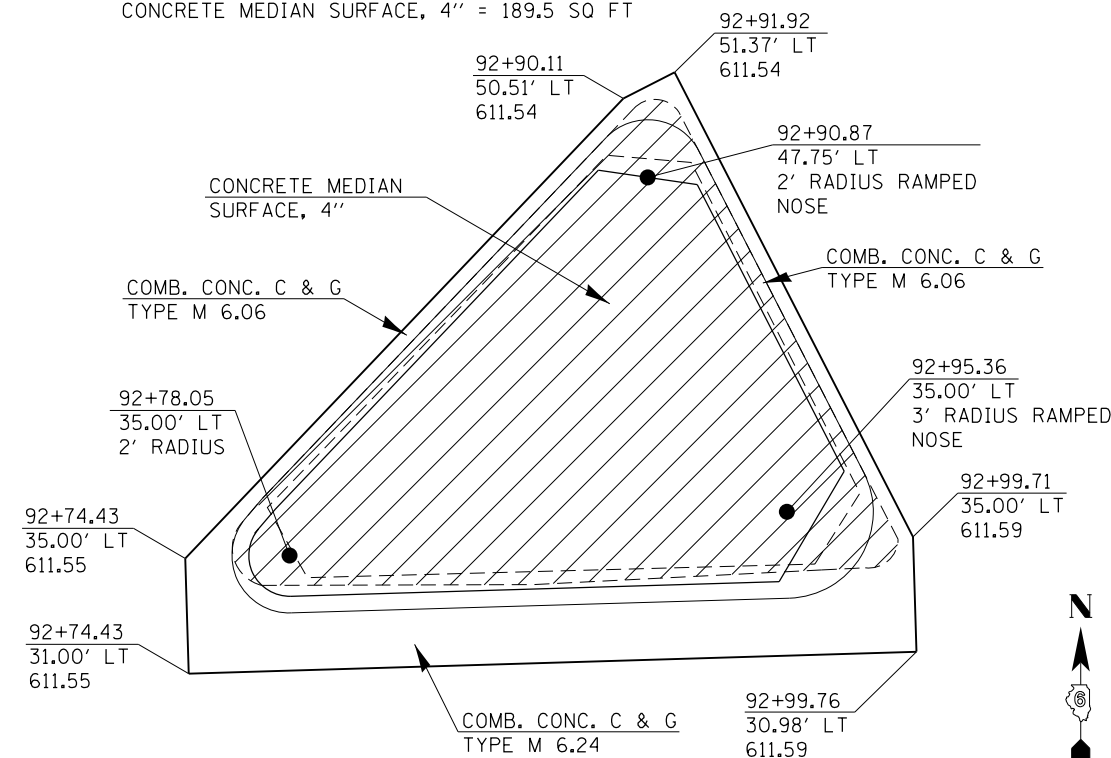

EXISTING CONCRETE CURB & GUTTER AND CONCRETE RAISED MEDIAN TO BE REMOVED

XX+XX.XX  
 XX.XX' LT or RT = STATION  
 XXX.XX PROPOSED ELEVATION

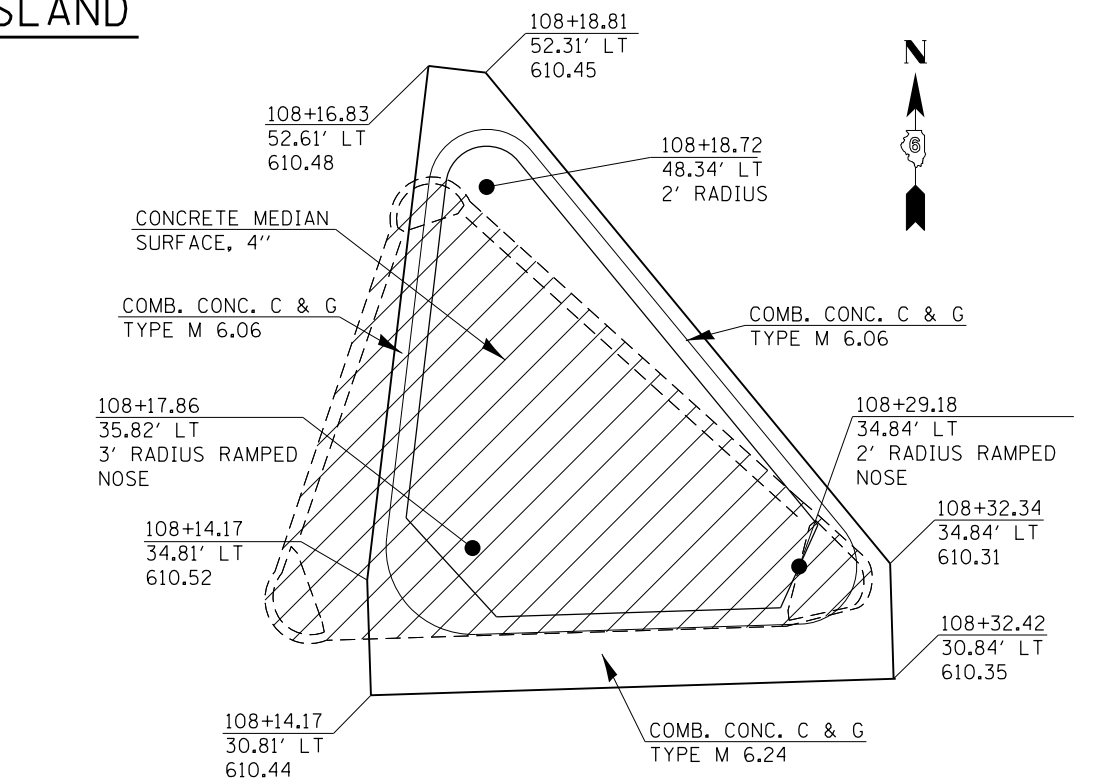

**N.B. I-55 ENTRANCE RAMP / IL 104 ISLAND  
 (STA. 108+20)**

**S.B. I-55 EXIT RAMP / IL 104 ISLAND  
 (STA. 92+90)**

FILE NAME =	USER NAME = sparksgw	DESIGNED - RTS	REVISED -	<b>STATE OF ILLINOIS DEPARTMENT OF TRANSPORTATION</b>	<b>RAISED CONCRETE ISLAND DETAILS</b>	F.A.P. RTE.	SECTION	COUNTY	TOTAL SHEETS	SHEET NO.
ct:\pwork\pwork\sparksgw\10245433\0672E12-sht-details.dgn	DRAWN - RTS	REVISED -	753			(140RS-6, 141RS-7)I	SANGAMON	98	66	
PLOT SCALE = 200.0000' / in.	CHECKED -	REVISED -	CONTRACT NO. 72E12							
PLOT DATE = Apr-09-2012 03:36:55PM	DATE - 3/26/12	REVISED -	ILLINOIS FED. AID PROJECT							
						SCALE:	SHEET 1 OF 1 SHEETS	STA.	TO STA.	