

When cantilever forming brackets are used, the work shall be done according to Article 503.06(b) of the Standard Specifications, except as modified below and in the details shown on this sheet.

The finishing machine rails shall be placed on the top flange of the exterior beams.

The beams or girders, supporting cantilever forming brackets, shall be tied together at 4 foot intervals.

For Standard construction, or Stage Construction the Hardwood bracing materials shall be placed as shown between webs of beams in each bay.

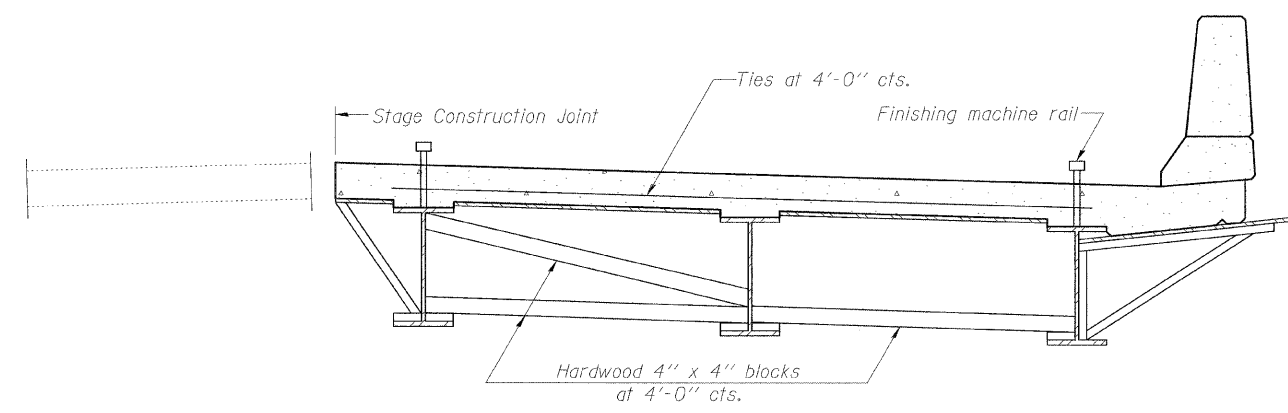

**FORM BRACES FOR  
STAGE CONSTRUCTION**

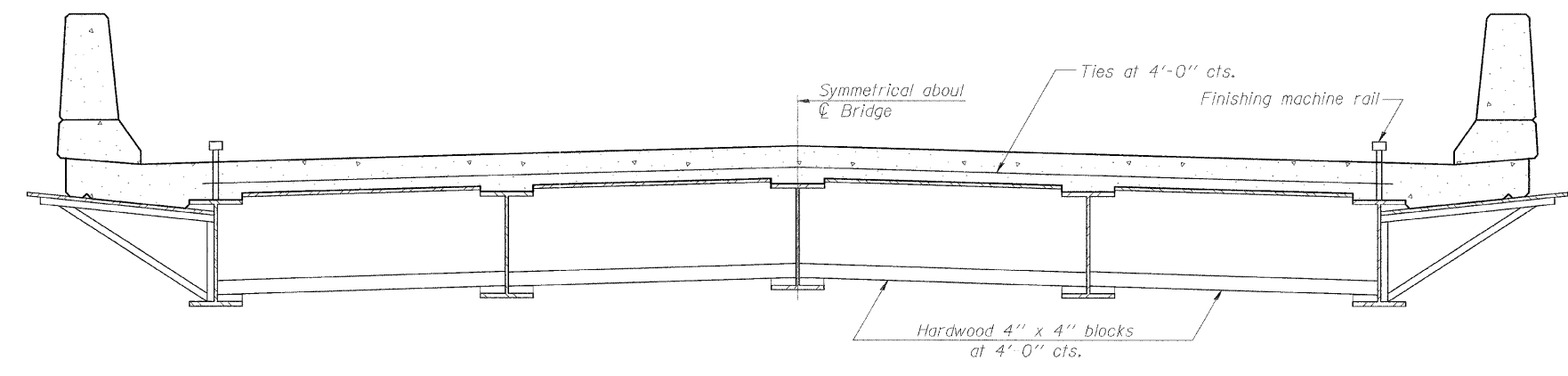

**FORM BRACES FOR  
STANDARD CONSTRUCTION**

SB-1

7-1-10

FILE NAME =	USER NAME = Brian K. Nicholson	DESIGNED - MJP	REVISED -
		CHECKED - KWB	REVISED -
		DRAWN - BKN	REVISED -
		CHECKED - KWB	REVISED -

**STATE OF ILLINOIS  
DEPARTMENT OF TRANSPORTATION**

**CANTILEVER FORMING BRACKETS FOR SUPERSTRUCTURES WITH  
W27 BEAMS AND SMALLER STRUCTURE NO. 058-6026**

SHEET NO. 18 OF 22 SHEETS

F.A.U. RTE.	SECTION	COUNTY	TOTAL SHEETS	SHEET NO.
7398	09-00905-00-BR	MACON	63	48
			CONTRACT NO. 95687	
ILLINOIS FED. AID PROJECT				

**URS**  
345 EAST ASH AVENUE, SUITE B  
DECATUR, ILLINOIS 62526  
PH. 217-875-4800