

PROPOSED TYPICAL SECTION

POPLAR STREET
STA. 4000+57 - STA. 4000+81

PAVEMENT DESIGN INFORMATION

(IN ACCORDANCE WITH IDOT LOCAL ROADS, MECHANISTIC-BASED PAVEMENT DESIGN PROCEDURES FOR RIGID PAVEMENT). USE THE SAME PAVEMENT STRUCTURE AS FOR MOORE ST.

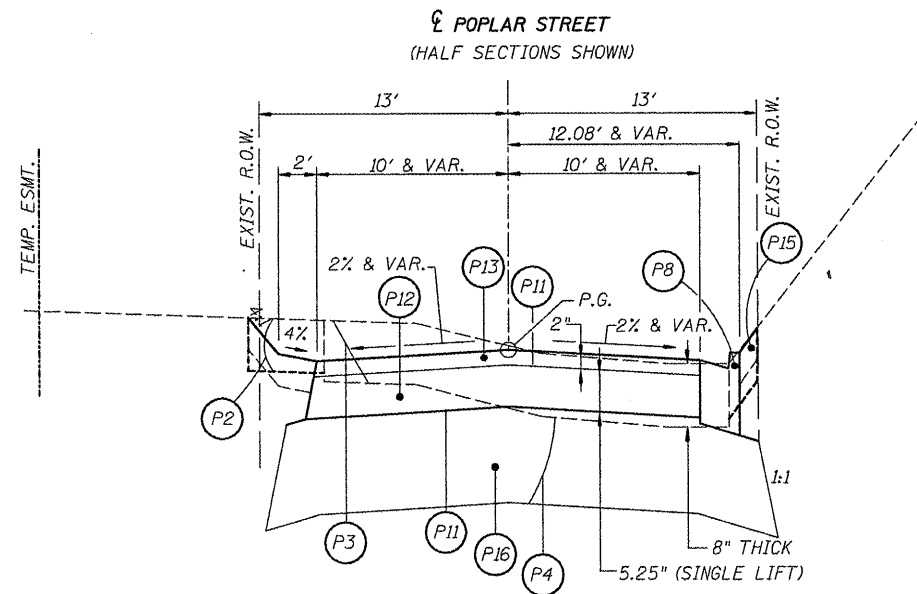

PROPOSED TYPICAL SECTION

POPLAR STREET
STA. 4000+35.92 - STA. 4000+57

PAVEMENT DESIGN INFORMATION

(IN ACCORDANCE WITH IDOT LOCAL ROADS, MECHANISTIC-BASED, FULL-DEPTH HMA PAVEMENT DESIGN PROCEDURES FOR FLEXIBLE PAVEMENT). USE THE SAME TRAFFIC AS FOR MOORE ST.

STRUCTURAL DESIGN TRAFFIC:

DESIGN YEAR: 2019
DESIGN YEAR ADT: 3,715
94.2% P.V., 4.7% S.U., 1.1% M.U.

ROAD/STREET CLASSIFICATION: CLASS II

TRAFFIC FACTOR = 0.45
SUBGRADE SUPPORT RATING: POOR
PG BINDER: 64-22

DESIGN PAVEMENT HMA TEMP: 83°F
DESIGN HMA MODULUS (E_{ac}): 480 ksi
DESIGN HMA MICROSTRAIN: 196.7

PAVEMENT THICKNESS: 7.25"
COMMENTS: DUE TO SMALL QUANTITIES, SOIL INVESTIGATION WAS NOT REQUIRED, THOUGH CORES WERE TAKEN SOUTH OF THE IMMEDIATE PROJECT. POOR SUBGRADE USED, BUT USE OF 12" MODIFIED SUBGRADE (AGGR.) REQUIRED.

PROPOSED TYPICAL SECTION LEGEND

- (P1) PAVEMENT REMOVAL, SIDEWALK REMOVAL, AND OTHER REMOVALS DENOTED ELSEWHERE IN THE PLANS
- (P2) TOPSOIL REMOVAL, 6" (PART OF PAY ITEM. SEE EARTHWORK SCHEDULE)
- (P3) REMOVAL AND DISPOSAL OF UNSUITABLE MATERIAL
- (P4) EARTH EXCAVATION
- (P5) EMBANKMENT (NOT A PAY ITEM. EARTH EXCAV. OR FURNISH. EXCAV. MATERIAL)
- (P6) EMBANKMENT (NOT A PAY ITEM. FURNISHED EXCAVATION MATERIAL)
- (P7) SUBBASE GRANULAR MATERIAL, TYPE A, 4"
- (P8) COMBINATION CONCRETE CURB AND GUTTER, TYPE B-6.18
- (P9) PORTLAND CEMENT CONCRETE PAVEMENT, 8" (JOINTED)
- (P10) SUBBASE GRANULAR MATERIAL, TYPE A, 8"
- (P11) BITUMINOUS MATERIALS (PRIME COAT) + AGGREGATE (PRIME COAT)
- (P12) HOT-MIX ASPHALT BINDER COURSE, IL-19.0, N70
- (P13) HOT-MIX ASPHALT SURFACE COURSE, MIX "D", N70
- (P14) PORTLAND CEMENT CONCRETE SIDEWALK, 4"
- (P15) TOPSOIL PLACEMENT, 4" (PART OF PAY ITEM. SEE EARTHWORK SCHEDULE)
- (P16) SUBBASE GRANULAR MATERIAL, TYPE A, 12"

* NO. 6 BARS, 30" LONG, AT 30" CENTERS (TYPICAL)
"SAWED LONGITUDINAL JOINT" PER IDOT HWY. STD. 420001.
NOTE THAT IF ADJOINING PANELS ARE POURED IN THE SAME POUR, THE JOINT DOES NOT NEED TO BE SAWN AFTER PLACEMENT.

** NO. 6 BARS, EPOXY-COATED, 30" LONG, AT 24" CENTERS (TYPICAL)
IF CURB AND GUTTER IS POURED MONOLITHICALLY WITH ADJOINING PAVEMENT, THE GUTTER PAN MUST BE 6% PER IDOT HWY. STD. 606001. TIE BARS CANNOT BE OMITTED W/MONOLITHIC POUR. THE EDGE OF PAVEMENT MUST BE SAWN AND SEALED, PER IDOT HWY. STD. 420001'S "SAWED LONGITUDINAL JOINT", IF CURB IS POURED MONOLITHICALLY, IF CURB IS POURED SEPARATE, BAR MUST STILL BE PLACED, BUT SAWN AND SEALED JOINT IS NOT REQUIRED.

MIXTURE COMPOSITION TABLE

MIXTURE USE:	SURFACE	BINDER
APPLICATION:	HOT-MIX ASPHALT SURFACE COURSE, MIX "D", N70	HOT-MIX ASPHALT BINDER COURSE, IL-19.0, N70
AIR VOIDS / Ndes:	4.0% AT Ndes 70	4.0% AT Ndes 70
PG BINDER GRADE:	PG 64-22	PG 64-22
MIXTURE COMPOSITION:	IL-9.5	IL-19.0
FRICTION AGGREGATE:	MIXTURE D	-
RAP % (MAX.):	10%	15%
MIXTURE WEIGHT:	112 LBS./SQ. YD./INCH	112 LBS./SQ. YD./INCH