

INDEX

06-15-2018 LETTING ITEM 108

- 1 COVER SHEET & LOCATION
- 2 GENERAL NOTES
- 3-6 SUMMARY OF QUANTITIES
- 7 TYPICAL SECTIONS
- 8-10 SCHEDULES
- 11-12 ADA DETAILS
- 13-18 DETAILS

LIST OF ILLINOIS DOT HIGHWAY STANDARDS

- 000001-06 STANDARD SYMBOLS, ABBREVIATIONS AND PATTERNS
- 001001-02 AREAS OF REINFORCEMENT BARS
- 001005 DECIMAL OF AN INCH AND OF A FOOT
- 406201-01 MAILBOX TURNOUT
- 424001-10 PERPENDICULAR CURB RAMPS FOR SIDEWALKS
- 424006-03 DIAGONAL CURB RAMPS FOR SIDEWALKS
- 424011-03 CORNER PARALLEL CURB RAMPS FOR SIDEWALKS
- 424016-04 MID-BLOCK CURB RAMPS FOR SIDEWALKS
- 424021-04 DEPRESSED CORNER FOR SIDEWALKS
- 424026-02 ENTRANCE / ALLEY PEDESTRIAN CROSSINGS
- 424031-01 MEDIAN PEDESTRIAN CROSSINGS
- 701001-02 OFF-ROAD OPERATIONS 2L, 2W, MORE THAN 15' (4.5 m) AWAY
- 701006-05 OFF-ROAD OPERATIONS 2L, 2W, 15' (4.5 m) TO 24' (600 mm) FROM PAVEMENT EDGE
- 701301-04 LANE CLOSURE, 2L, 2W, SHORT TIME OPERATIONS
- 701306-04 LANE CLOSURE, 2L, 2W, SLOW MOVING OPERATIONS DAY ONLY, FOR SPEEDS > 45 MPH
- 701311-03 LANE CLOSURE, 2L, 2W, MOVING OPERATIONS - DAY ONLY
- 701801-06 SIDEWALK, CORNER OR CROSSWALK CLOSURE
- 701901-07 TRAFFIC CONTROL DEVICES
- 780001-05 TYPICAL PAVEMENT MARKINGS
- 781001-04 TYPICAL APPLICATIONS RAISED REFLECTIVE PAVEMENT MARKERS

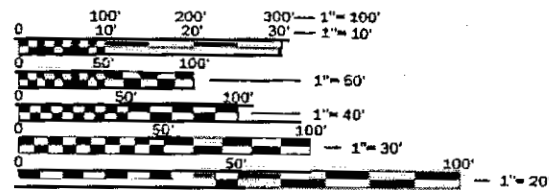

FULL SIZE PLANS HAVE BEEN PREPARED USING STANDARD ENGINEERING SCALES. REDUCED SIZED PLANS WILL NOT CONFORM TO STANDARD SCALES. IN MAKING MEASUREMENTS ON REDUCED PLANS, THE ABOVE SCALES MAY BE USED.

J.U.L.I.E.
JOINT UTILITY LOCATION INFORMATION FOR EXCAVATION
1-800-892-0123
OR 811

PROJECT ENGINEER: BRAD DUNCAN, PE
UNIT CHIEF: JESSY JEAN
DISTRICT 3 NO. (815) 434-6131
CONTRACT NO. 66838

STATE OF ILLINOIS
DEPARTMENT OF TRANSPORTATION

**PROPOSED
HIGHWAY PLANS**

FAU ROUTE 2503 (IL 25)
SECTION (35) RS-4
PROJECT: STP-M316(324)
3P MILLING & RESURFACING
KENDALL COUNTY

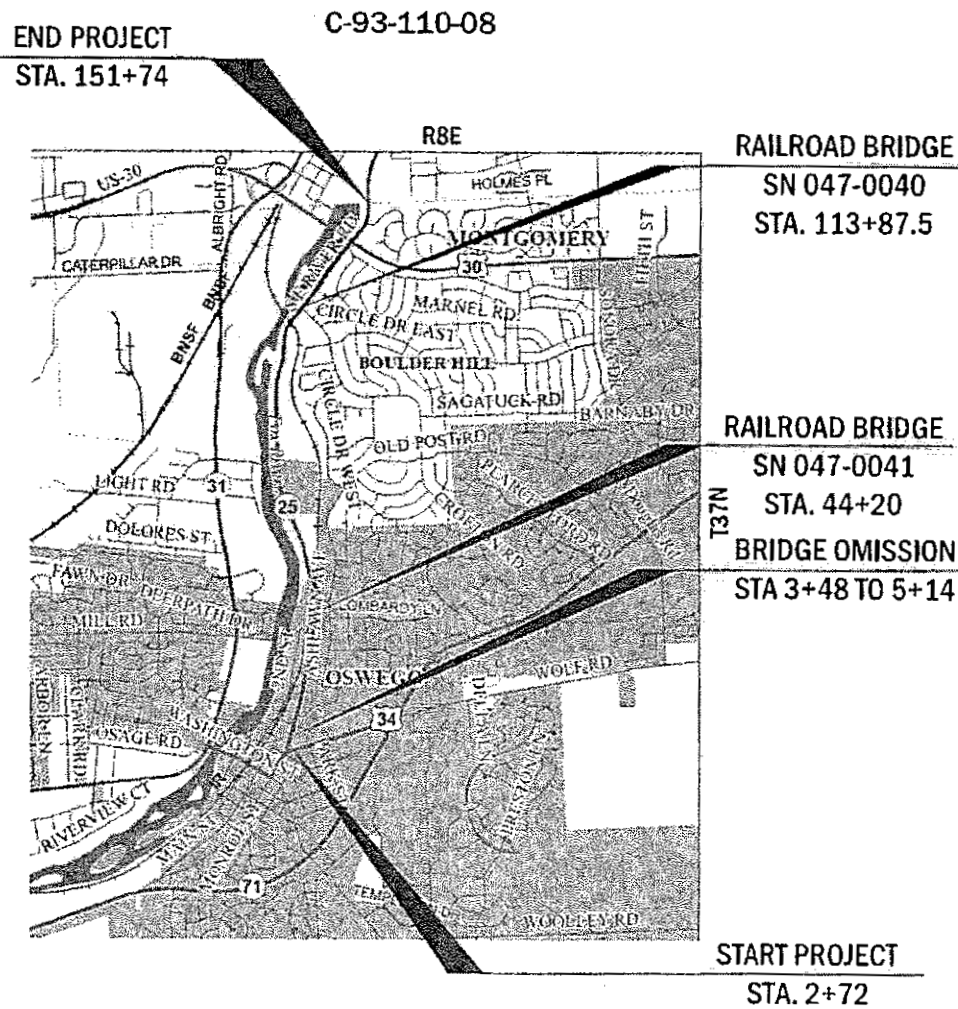

GROSS LENGTH = 14,902 = 2.822 MILE
NET LENGTH = 14,736 = 2.791 MILE

F.A.P. RITE	SECTION	COUNTY	TOTAL SHEETS	SHEET NO.
2503	(35) RS-4	KENDALL	18	1
CONTRACT NO. 66838				

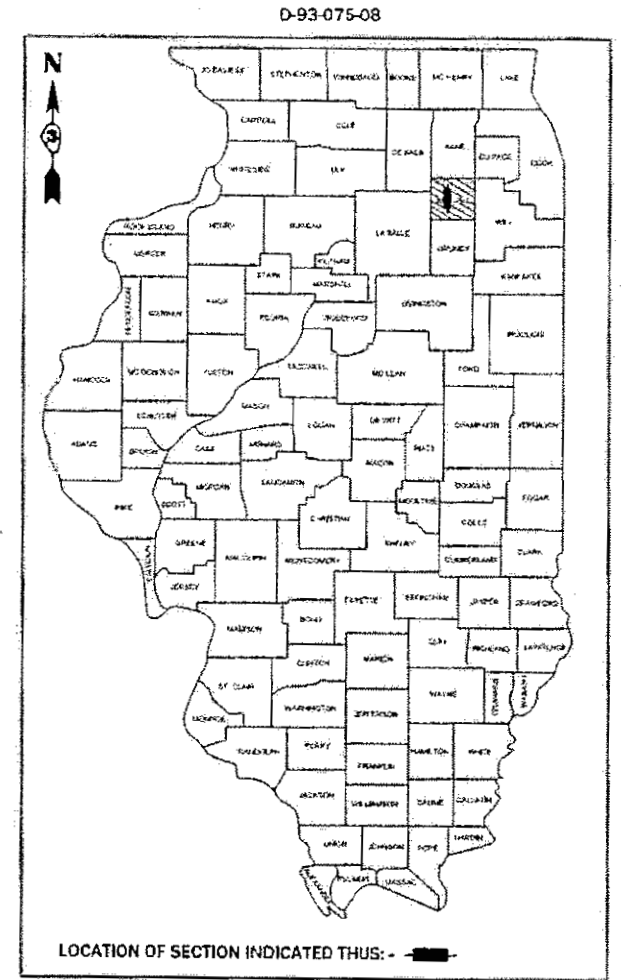

FUNCTIONAL CLASSIFICATION
URBAN MINOR ARTERIAL
2017 ADT = 5250
P.V. = 97.39% S.U. = 2.48% M.U. = 0.13%

STATE OF ILLINOIS
DEPARTMENT OF TRANSPORTATION

SUBMITTED 3-22 2018

[Signature]
REGIONAL ENGINEER

[Signature]
ENGINEER OF DESIGN AND ENVIRONMENT

[Signature]
DIRECTOR OF HIGHWAYS PROJECT IMPLEMENTATION

PRINTED BY THE AUTHORITY
OF THE STATE OF ILLINOIS

GENERAL NOTES

THE THICKNESS OF HMA SHOWN ON THE PLANS IS THE NOMINAL THICKNESS. DEVIATIONS FROM THE NOMINAL THICKNESS WILL BE PERMITTED WHEN SUCH DEVIATIONS OCCUR DUE TO IRREGULARITIES IN THE EXISTING SURFACE OR BASE ON WHICH THE HMA IS PLACED.

THE HMA SURFACE OF ALL MAILBOX TURNOUTS, PRIVATE ENTRANCES, COMMERCIAL ENTRANCES, AND SIDE ROADS SHALL BE MADE NEATLY, IN A WORKMANLIKE MANNER, AND SHALL ACCURATELY CONFORM TO THE SHAPES AND DIMENSIONS SHOWN ON THE PLAN DETAILS. IF REQUIRED BY THE ENGINEER, THE CONTRACTOR SHALL SAW CUT THE HMA SURFACE TO CONFORM TO THE SHAPES AND DIMENSIONS SHOWN ON THE PLAN DETAILS. THIS WORK WILL BE INCLUDED IN THE COST OF THE HMA SURFACE.

THE ENGINEER WILL BE THE SOLE JUDGE CONCERNING CURING TIME FOR THE VARIOUS HMA LIFTS.

SEEDING WILL NOT BE PERMITTED AT ANY TIME WHEN THE GROUND IS FROZEN, WET, OR IN AN UNTILLABLE CONDITION. LOCATIONS TO BE SEEDED WILL BE DETERMINED BY THE ENGINEER.

THE FINISHED EARTHWORK SHALL HAVE A VEGETATION SUSTAINING SOIL COVERING THE TOP FOUR INCHES (100 MILLIMETERS) IN AREAS TO BE SEEDED OR SODDED. THE VEGETATION SUSTAINING SOIL REQUIRED WILL NOT BE PAID FOR SEPARATELY BUT WILL BE INCLUDED IN THE COST OF FURNISHED EXCAVATION.

DETECTABLE WARNING SURFACES SHALL EXTEND 2.0 FT MINIMUM IN THE DIRECTION OF PEDESTRIAN TRAVEL. AT CURB RAMPS AND BLENDED TRANSITIONS, DETECTABLE WARNING SURFACES SHALL EXTEND THE FULL WIDTH OF THE RAMP RUN (EXCLUDING ANY FLARES) OR BLENDED TRANSITIONS. SOME DETECTABLE WARNING PRODUCTS REQUIRE A CONCRETE BORDER FOR PROPER INSTALLATION. THE CONCRETE BORDER SHALL NOT EXCEED 2 INCHES.

ANY REFERENCE TO A STANDARD IN THESE PLANS SHALL BE INTERPRETED TO MEAN THE EDITION AS INDICATED BY THE SUBNUMBER SHOWN IN THE LIST OF STANDARDS OR THE COPY INCLUDED IN THESE PLANS.

THE FOLLOWING RATES OF APPLICATION HAVE BEEN USED IN CALCULATING PLAN QUANTITIES:

GRANULAR MATERIALS	2.05	TONS / CU YD
HMA RESURFACING	112	LBS / SQ YD / IN
SHORT TERM PAVEMENT MARKING	10	FT / 100 FT OF APPLICATION
MIX FOR CRACKS, JTS & FLGWYS	0.0003	TONS / SQ YD
LEVEL BINDER (HAND METHOD)	0.0005	TONS / SQ YD

THE CONTRACTOR SHALL CONTACT JULIE AT LEAST 48 HOURS PRIOR TO EXCAVATION TO DETERMINE WHICH UTILITIES ARE IN THE AREA.

ENVIRONMENTAL COMMITMENTS

ANYALL EXCAVATED MATERIAL MUST REMAIN ON SITE.

STATE OF ILLINOIS
DEPARTMENT OF TRANSPORTATION
DISTRICT THREE
AS BUILT INFORMATION

SUPERVISING CONSTRUCTION FIELD ENGINEER

RESIDENT ENGINEER / TECHNICIAN

START & END DATES
OF CONSTRUCTION:

INSPECTORS:

STATE OF ILLINOIS
DEPARTMENT OF TRANSPORTATION
DISTRICT THREE

PREPARED BY: Tom Benick
DISTRICT STUDIES & PLANS ENGINEER

DATE: 3-22-18

EXAMINED BY: Kip Vigor
DISTRICT CONSTRUCTION ENGINEER

Michael Strait
DISTRICT MATERIALS ENGINEER

Tom Gray
DISTRICT OPERATIONS ENGINEER

FILE NAME *	USER NAME * ferguacrh	DESIGNED -	REVISED -	STATE OF ILLINOIS DEPARTMENT OF TRANSPORTATION	GENERAL NOTES AND COMMITMENTS	P.A.P. RISE.	SECTION	COUNTY	TOTAL SHEETS	SHEET NO.	
\\s01ll04\ES\INTEG\Bldg\gov\FW\DOT\Documents\DOT\Office\District 3\Projects\0386438-CADD\DWG\CAD\sheet0386438.dwg	ORWAY\m	CHECKED -	REVISED -			2503	(35) RS-4	KENDALL	19	2	
PLT SCALE * 100.0000 / in.		DATE -	REVISED -			CONTRACT NO. 66838					
PLT DATE * 3/21/2018						SCALE:	SHEET	OF	SHEETS	STA.	TO STA.

CODE NO.	ITEM	UNIT	TOTAL QUANTITY	CONSTR. CODE	
				80% FEDERAL 20% STATE	
				ROADWAY	
				0005	URBAN
20400800	FURNISHED EXCAVATION	CU YD	9	9	
40200800	AGGREGATE SURFACE COURSE, TYPE B	TON	15	15	
40600290	BITUMINOUS MATERIALS (TACK COAT)	POUND	29923	29923	
40600400	MIXTURE FOR CRACKS, JOINTS, AND FLANGEWAYS	TON	13	13	
40600537	LEVELING BINDER (HAND METHOD), IL-9.5FG, N70	TON	21	21	
40600637	LEVELING BINDER (MACHINE METHOD), IL-9.5FG, N70	TON	1716	1716	
40600990	TEMPORARY RAMP	SQ YD	307	307	
40603340	HOT-MIX ASPHALT SURFACE COURSE, MIX "D", N70	TON	3542	3542	
40800050	INCIDENTAL HOT-MIX ASPHALT SURFACING	TON	298	298	
42400100	PORTLAND CEMENT CONCRETE SIDEWALK 4 INCH	SQ FT	275	275	
42400800	DETECTABLE WARNINGS	SQ FT	76	76	
44000155	HOT-MIX ASPHALT SURFACE REMOVAL, 1 1/2"	SQ YD	4430	4430	
44000158	HOT-MIX ASPHALT SURFACE REMOVAL, 2 1/4"	SQ YD	40846	40846	
44000500	COMBINATION CURB AND GUTTER REMOVAL	FOOT	15	15	

14

* SPECIALTY ITEMS

FILE NAME =	USER NAME = jeorJJ	DESIGNED -	REVISED -	STATE OF ILLINOIS DEPARTMENT OF TRANSPORTATION	SUMMARY OF QUANTITIES				F.A.U. RTE. 2503	SECTION (35)RS-4	COUNTY KENDALL	TOTAL SHEETS 19	SHEET NO. 3
pw\ill084EBID\INTEG\illinois.gov\PWIDOT\Documents\DOT Offices\District 3\Projects\03688388\Drawings\CAD\Sheets\03688388-sht-900.dwg		DRAWN -	REVISED -		SCALE:	SHEET 1	OF 3 SHEETS	STA.	TO STA.	CONTRACT NO. 66838			
		CHECKED -	REVISED -		ILLINOIS FED. AID PROJECT								
Default		DATE -	REVISED -										

CODE NO.	ITEM	UNIT	TOTAL QUANTITY	CONSTR. CODE	
				80% FEDERAL ROADWAY	20% STATE URBAN
70300280	TEMPORARY PAVEMENT MARKING - LINE 24"	FOOT	52	52	
* 78009000	MODIFIED URETHANE PAVEMENT MARKING - LETTERS AND SYMBOLS	SQ FT	93.6	93.6	
* 78009004	MODIFIED URETHANE PAVEMENT MARKING - LINE 4"	FOOT	92068	92068	
* 78009006	MODIFIED URETHANE PAVEMENT MARKING - LINE 6"	FOOT	4316	4316	
* 78009008	MODIFIED URETHANE PAVEMENT MARKING - LINE 8"	FOOT	540	540	
* 78009012	MODIFIED URETHANE PAVEMENT MARKING - LINE 12"	FOOT	1132	1132	
* 78009024	MODIFIED URETHANE PAVEMENT MARKING - LINE 24"	FOOT	52	52	
* 78100100	RAISED REFLECTIVE PAVEMENT MARKER	EACH	302	302	
78300200	RAISED REFLECTIVE PAVEMENT MARKER REMOVAL	EACH	302	302	
X0327980	PAVEMENT MARKING REMOVAL - WATER BLASTING	SQ FT	17268	17268	
X4401198	HOT-MIX ASPHALT SURFACE REMOVAL, VARIABLE DEPTH	SQ YD	460	460	
Z0030850	TEMPORARY INFORMATION SIGNING	SQ FT	42	42	
Z0033700	LONGITUDINAL JOINT SEALANT	FOOT	14715	14715	
Z0034105	MATERIAL TRANSFER DEVICE	TON	5258	5258	
Z0048665	RAILROAD PROTECTIVE LIABILITY INSURANCE	L SUM	1	1	

15

* SPECIALTY ITEMS

FILE NAME =	USER NAME = jeerj	DESIGNED -	REVISED -	STATE OF ILLINOIS DEPARTMENT OF TRANSPORTATION	SUMMARY OF QUANTITIES		F.A.U. RTE.	SECTION	COUNTY	TOTAL SHEETS	SHEET NO.
p:\1\084EBIDINTEG\Illinois.gov\IDOT\Documents\IDOT Offices\District 3\Projects\2368-DRAWN\Drawings\6A0\Sheets\0368038-ht-500.dwg	PLLOT SCALE = 100.0000' / in.	CHECKED -	REVISED -				2503	(35)RS-4	KENDALL	19	5
Default	PLLOT DATE = 3/22/2018	DATE -	REVISED -				SCALE:	SHEET 3 OF 3 SHEETS	STA.	TO STA.	CONTRACT NO. 66838
											ILLINOIS FED. AID PROJECT

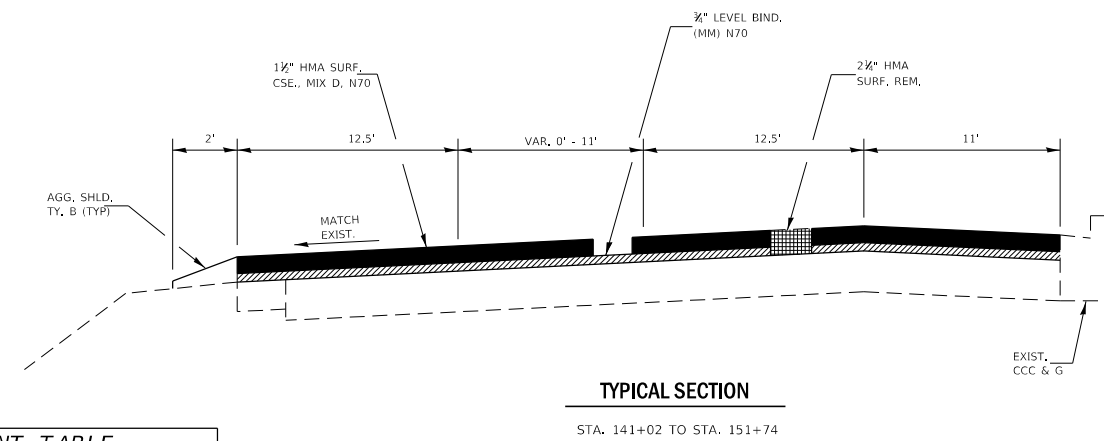
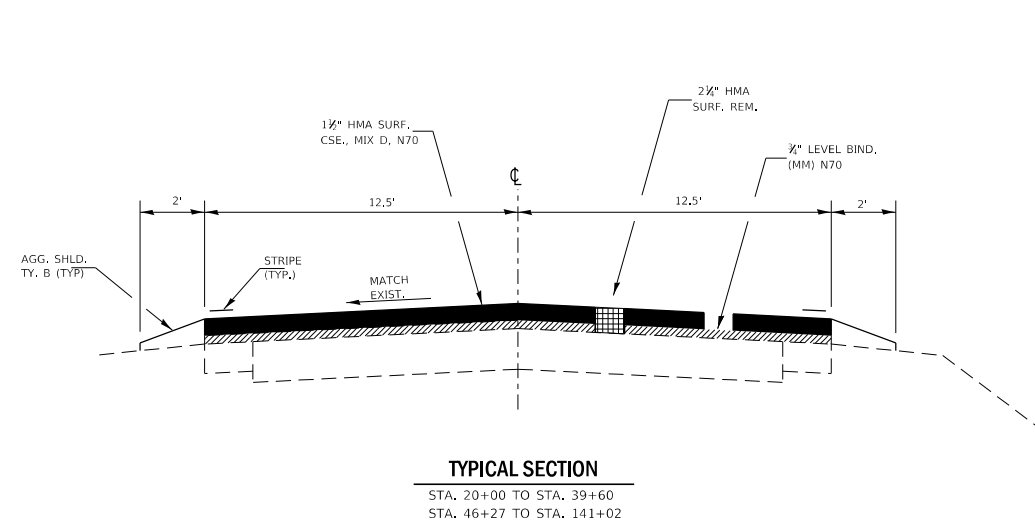
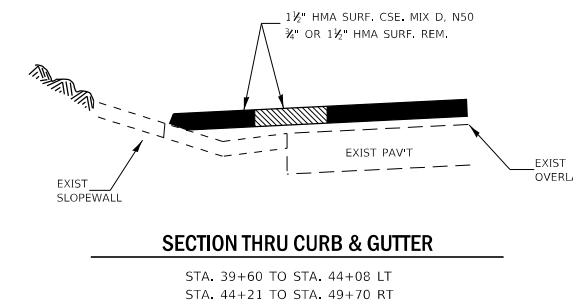
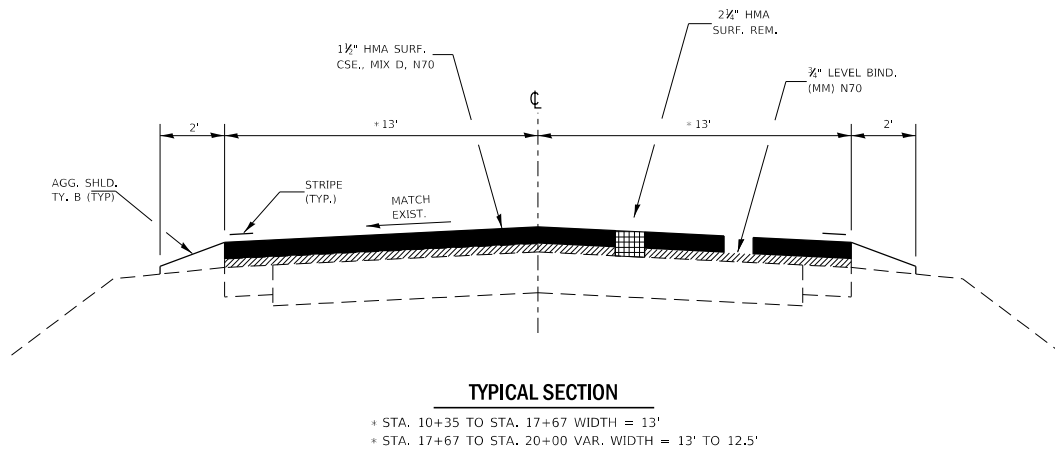
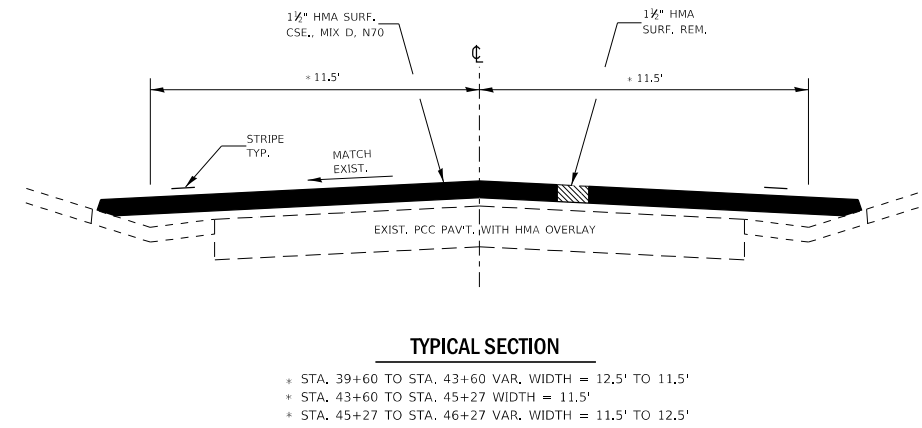
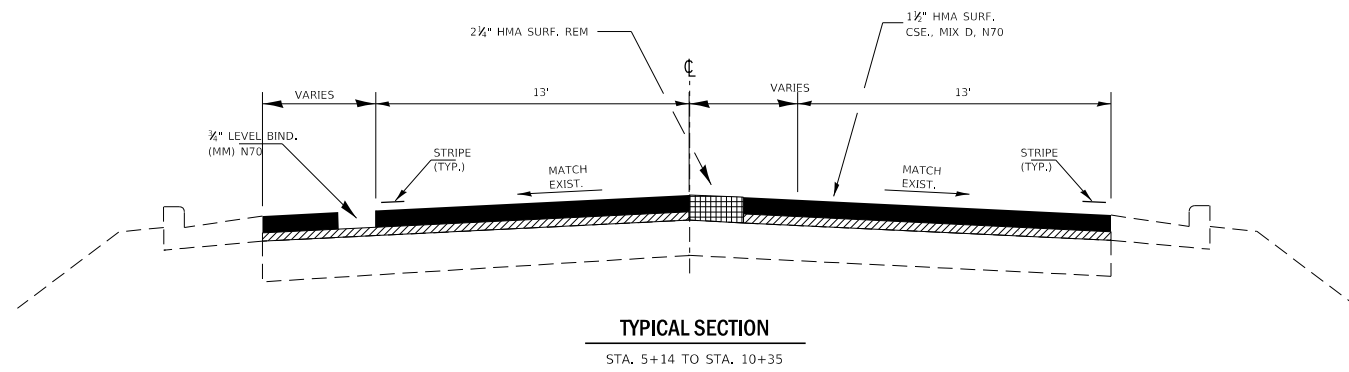

HMA MIXTURE REQUIREMENT TABLE		
LOCATION(S):	ENTIRE PROJECT	ENTIRE PROJECT
MIXTURE USE(S):	HMA LEVEL BINDER	HMA SURFACE
BINDER GRADE (PG):	PG64-22	PG64-22
DESIGN AIR VOIDS:	4.0% @ N70	4.0% @ N70
MIXTURE COMPOSITION: (MIXTURE GRADATION)	1L 9.5FG	1L 9.5
FRICTION AGGREGATE:		MIXTURE D
MIXTURE WEIGHT:	112.0 LB/SY/IN	112.0 LB/SY/IN
QUALITY MANAGEMENT PROGRAM:	QCP	QCP
SUBLOT SIZE:	1000 TONS	1000 TONS
DENSITY TEST METHOD:	% GROWTH CURVE	CORES

FILE NAME =	USER NAME = jeonjj	DESIGNED -	REVISED -
pw:\11084EBIDINTEG.illinois.gov\PIWIDOT\Documents\DOT Offices\District 3\Projects\0366838\Drawings\0366838-shd-typical		CHECKED -	REVISED -
		DATE -	REVISED -

STATE OF ILLINOIS
DEPARTMENT OF TRANSPORTATION

TYPICAL SECTIONS

SCALE: SHEET 1 OF 1 SHEETS STA. TO STA.

F.A.U. RTE.	SECTION	COUNTY	TOTAL SHEETS	SHEET NO.
2503	(35)RS-4	KENDALL	19	6
CONTRACT NO. 66838				
ILLINOIS FED. AID PROJECT				

MAINLINE SCHEDULE															
STA. TO STA.		AREA	HMA SURF REM 1 1/2"	HMA SURF REM 2 1/4"	HMA SURF REM (VAR. D)	LONG JOINT SEALANT	HMA SURF CSE MIX "D" N70	LEVEL BINDER (MM) 1L-9.5FG	LEVEL BINDER (HM) 1L-9.5FG	SHORT TERM PAV'T MKG* PAV'T	SHRT TRM PAV'T MKG REM	MIX FOR JTS, CRACKS & FLGWYS	BIT. MAT'L (TACK CT)	AGG SHLD TY B	TEMP RAMP
		SQ YD	SQ YD	SQ YD	SQ YD	FOOT	TON	TON	TON	FOOT	SQ FT	TON	POUND	TON	SQ YD
2+72	3+48	346		346		152	29.1	14.5	0.2	23	3	0.1	233.6		66.7
3+48	5+14	BRIDGE OMISSION													
5+14	10+35	1609		1609		521	135.2	67.6	0.8	156	17	0.5	1086.1		33.3
10+35	10+95	174		174		60	14.6	7.3	0.1	18	2	0.1	117.5	4	
10+95	17+67	1942		1942		672	163.1	81.6	1.0	202	22	0.6	1310.9	35	
17+67	20+00	661		661		233	55.5	27.8	0.3	70	8	0.2	446.2	13	
20+00	39+60	5445		5445		1960	457.4	228.7	2.7	588	65	1.6	3675.4	118	
39+60	43+60	1068	240	828		400	89.7	34.8	0.5	120	13	0.3	720.9	3	
43+60	45+27	427	427			167	35.9		0.2	50	6	0.1	288.2	5	
45+27	46+27	267	112	155		100	22.4	6.5	0.1	30	3	0.1	180.2	3	
46+27	112+60	18425		18425		6633	1547.7	773.9	9.2	1990	221	5.5	12436.9	334	
112+60	115+15	709	542	167	460	255	59.6	7.0	0.4	77	9	0.2	478.6	14	
115+15	140+42	7020		7020		2527	589.7	294.8	3.5	758	84	2.1	4738.5	131	
140+42	141+02	167		167		60	14.0	7.0	0.1	18	2	0.1	112.7	4	
141+02	145+67	2217		2217		465	186.2	93.1	1.1	140	16	0.7	1496.5		
145+67	150+77	1690		1690		510	142.0	71.0	0.8	441	49	0.5	1140.8		33.3
GRAND TOTALS		42,167	1,321	40,846	460	14,715	3,542	1,716	21	4,680	520	13	28,463	664	133

*INCLUDES 3 APPLICATIONS FOR CENTERLINE AND LEFT TURN ARROWS AT RIVER BEND RD

PAVEMENT MARKING SCHEDULE												
LOCATION	MODIFIED URETHANE PAVEMENT MARKING (2 APPLICATIONS)									RAISED REFLECTIVE PAVEMENT MARKERS		RAISED REFL PVT MKRS REMOVAL
	YELLOW 4"	WHITE 4"	YELLOW 6"	WHITE 6"	WHITE 8"	YELLOW 12"	WHITE 12"	WHITE 24"	LET & SYM	CRYSTAL EACH	AMBER EACH	EACH
STA	FOOT	FOOT	FOOT	FOOT	FOOT	FOOT	FOOT	FOOT	SQ FT			
2+72 TO 3+48	608	152			26	108	8				4	4
5+14 TO 10+35	1822	678	140			28	32	52			20	20
10+35 TO 141+02		52268	3860	100			160				220	220
141+02 TO 145+67	2780	1540			254	260	50		31.2	3	25	28
145+67 TO 150+77	3084	1418		216	260	270	216		62.4	4	26	30
NORTHBOUND (NPZ)												
21+50 TO 53+84	6468											
62+70 TO 71+02	1664											
87+43 TO 114+44	5402											
138+80 TO 141+02	444											
SOUTHBOUND (NPZ)												
30+48 TO 63+62	6628											
69+72 TO 77+82	1620											
94+37 TO 121+83	5492											
SUBTOTALS	36012	56056	4000	316	540	666	466	52	94	7	295	302
GRAND TOTALS	92068		4316		540	1132		52	93.6	302		302

(1) R.E. TO VERIFY NO PASSING ZONES PRIOR TO MILLING OPERATION

*NOTE: MODIFIED URETHANE PAVEMENT MARKING WILL BE APPLIED IN 2 SEPARATE APPLICATIONS.

TEMPORARY PAVEMENT MARKING SCHEDULE										
LOCATION	TEMP PAVEMENT MARKING (2 APPLICATIONS)									PVT MK REM WTR BLST
	YELLOW 4"	WHITE 4"	YELLOW 6"	WHITE 6"	WHITE 8"	YELLOW 12"	WHITE 12"	WHITE 24"	PVT MK LET & SYM	
STA	FOOT	FOOT	FOOT	FOOT	FOOT	FOOT	FOOT	FOOT	SQ FT	SQ FT
2+72 TO 3+48	608	152			26	108	8			193
5+14 TO 10+35	1822	678	140			28	32	52		534
10+35 TO 141+02		52268	3860	100			160			9781
141+02 TO 145+67	2780	1540			254	260	50		31.2	975
145+67 TO 150+77	3084	1418		216	260	270	216		62.4	1165
NORTHBOUND (NPZ)										
21+50 TO 53+84	6468									1078
62+70 TO 71+02	1664									277
87+43 TO 114+44	5402									900
138+80 TO 141+02	444									74
SOUTHBOUND (NPZ)										
30+48 TO 63+62	6628									1105
69+72 TO 77+82	1620									270
94+37 TO 121+83	5492									915
SUBTOTALS	36012	56056	4000	316	540	666	466	52	94	17268
GRAND TOTALS	92068		4316		540	1132		52	93.6	17268

DRAINAGE SCHEDULE		
STATION		MANHOLE ADJ WITH NEW TY 1, OPEN LID
		EACH
117+01	21' RT	1
118+00	16' RT	1
TOTAL		2

CURB & SIDEWALK SCHEDULE					
DESCRIPTION	COMB CURB & GUTTER REM	SIDEWALK REM	CCC&G TYPE B-6.24	PCC SIDEWALK 4"	DETECTABLE WARNING
	FOOT	SQ FT	FOOT	SQ FT	SQ FT
RIVER BEND RD					
NE QUAD	15	119.0	15	119.0	17
NW QUAD		31.0		31.0	10
NORTH BIKE PATH					
NW QUAD		29.0		29.0	10
VIOLET PATCH PARK					
NE QUAD		48.0		48.0	19
NW QUAD		48.0		48.0	20
TOTALS	15	275	15	275.0	76

SIDE ROAD & ENTRANCES										
STATION	RT/LT	SIDEROAD OR DESCRIPTION	EXIST MAT'L	AREA	HMA SURFACE REMOVAL 1 1/2"	INCIDENTAL HMA SURF	BIT MATLS TACK CT	TEMP RAMP FOR SIDEROAD	AGG SURF CSE TY B	*FURNISHED EXCAVATION
				SQ YD	SQ YD	TON	POUND	SQ YD	TON	CU YD
7+08	LT	NORTH ST.	BIT	127	127	11	57.2	11.0		
9+48	RT	STONGATE RD.	BIT	157	157	14	70.7	15.0		
10+96	LT	PE / MBTO	BIT	53	53	5	23.9			
12+73	LT	PE / MBTO	BIT	46	46	4	20.7			
13+67	LT	PE / MBTO	BIT	92	92	8	41.4			
14+82	LT	PE / MBTO	BIT	40	40	4	18.0			
16+40	RT	PE / MBTO	BIT	103	103	9	46.4			
17+50	LT	MBTO	BIT	19	19	2	8.6			
18+30	LT	MBTO	BIT	18	18	2	8.1			
18+70	RT	PE	BIT	19	19	2	8.6			
19+67	RT	ELMWOOD DR.	BIT	118	118	10	53.1	14.0		2.0
20+52	RT	PE	BIT	22	22	2	9.9			
21+72	LT	PE / MBTO	BIT	35	35	3	15.8			
21+97	RT	PE / MBTO	BIT	27	27	3	12.2			
23+65	RT	PE / MBTO	BIT	40	40	4	18.0			
25+69	RT	PE / MBTO	BIT	39	39	4	17.6			
26+80	LT	PE / MBTO	AGG / BIT	136		15	61.2		6.0	
27+98	RT	PE	BIT	16	16	2	7.2			
28+50	RT	PE	BIT	22	22	2	9.9			
30+25	RT	PE	BIT	21	21	2	9.5			
32+07	LT	SECOND ST.	BIT	114	114	10	51.3	12.0		2.0
32+38	RT	CE	BIT	48	48	5	21.6			
35+41	LT	PE / MBTO	BIT	34	34	3	15.3			
39+60	RT	GLENDALE AVE.	BIT	140	140	12	63.0	13.0		2.0
46+35	LT	PE	BIT	154	154	13	69.3			
48+15	LT	PE	BIT	34	34	3	15.3			
49+10	RT	FE	AGG / BIT							
53+20	RT	PE / MBTO	BIT	43	43	4	19.4			
63+48	LT	CE	BIT	24	24	3	10.8			
63+90	RT	BIKE PATH	CONC							
63+90	LT	BIKE PATH	CONC							
77+44	RT	CE	BIT	55	55	5	24.8			
80+85	RT	PE / MBTO	AGG	33					3.0	
83+69	RT	FE	AGG							
87+13	RT	PE / MBTO	AGG	27					3.0	
89+12	RT	PE / MBTO	BIT	120	120	11	54.0			
93+50	RT	PE / MBTO	AGG	39					3.0	
94+00	RT	PE / MBTO	BIT	31	31	3	14.0			
95+18	RT	PE / MBTO	BIT	39	39	4	17.6			
97+34	RT	PE / MBTO	BIT	49	49	5	22.1			
97+87	RT	PE	BIT	15	15	2	6.8			
98+80	RT	PE / MBTO	BIT	35	35	3	15.8			
99+78	RT	PE / MBTO	BIT	36	36	4	16.2			
100+00	LT	BIKE PATH	CONC							
101+51	RT	PE / MBTO	BIT	33	33	3	14.9			
102+85	RT	PE / MBTO	BIT	43	43	4	19.4			
106+68	RT	PE / MBTO	BIT	38	38	4	17.1			
107+95	RT	PE / MBTO	BIT	32	32	3	14.4			
109+10	RT	PE / MBTO	BIT	38	38	4	17.1			
112+65	RT	FE	AGG							
116+66	RT	CE	BIT	253	253	22	113.9			
118+25	RT	BOLDERHILL PASS	BIT	230	230	20	103.5	35.0		
123+24	RT	RIVER DR.	BIT	120	120	11	54.0	13.0		
137+90	RT	FERNWOOD DR.	BIT	219	219	19	98.6	18.0		
145+67	RT	RIVER BEND RD.	BIT	118	118	10	53.1	43.0		
TOTALS					3109	298	1460	174	15	6

*PLACE FURNISHED EXCAVATION AROUND SIDEROAD RADII. THIS AREA TO BE SEEDED (SEEDING CLASS 1A), FERTILIZED AND COVERED WITH EROSION CONTROL BLANKET- NOT PAID FOR SEPERATELY BUT INCLUDED IN THE COST OF FURNISHED EXCAVATION
 ALL MAILBOX TURNOUTS TO BE MILLED AND PAVED. ONLY THOSE MBTO ON OPPOSITE SIDE OF ROADS ARE BROKEN OUT ABOVE

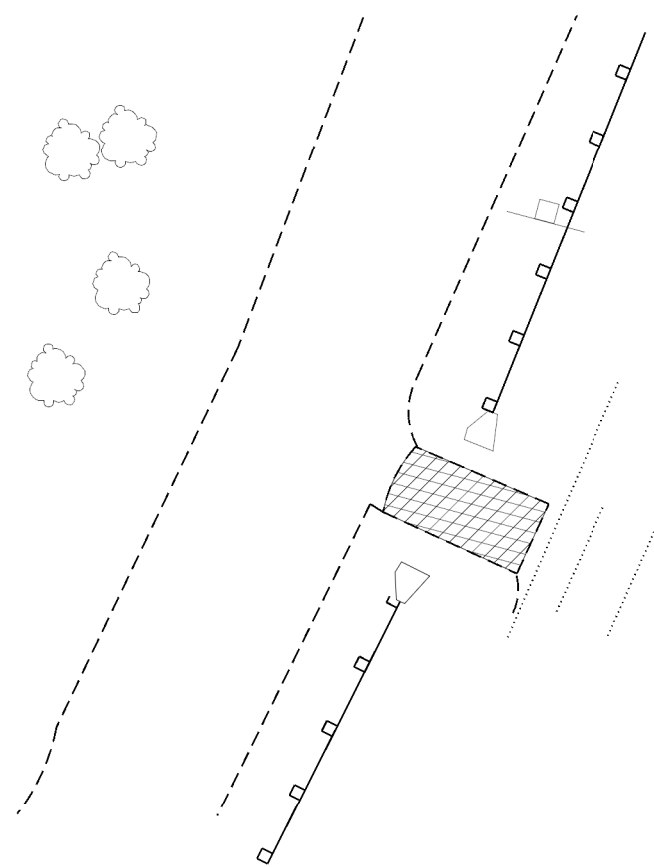

NW QUAD

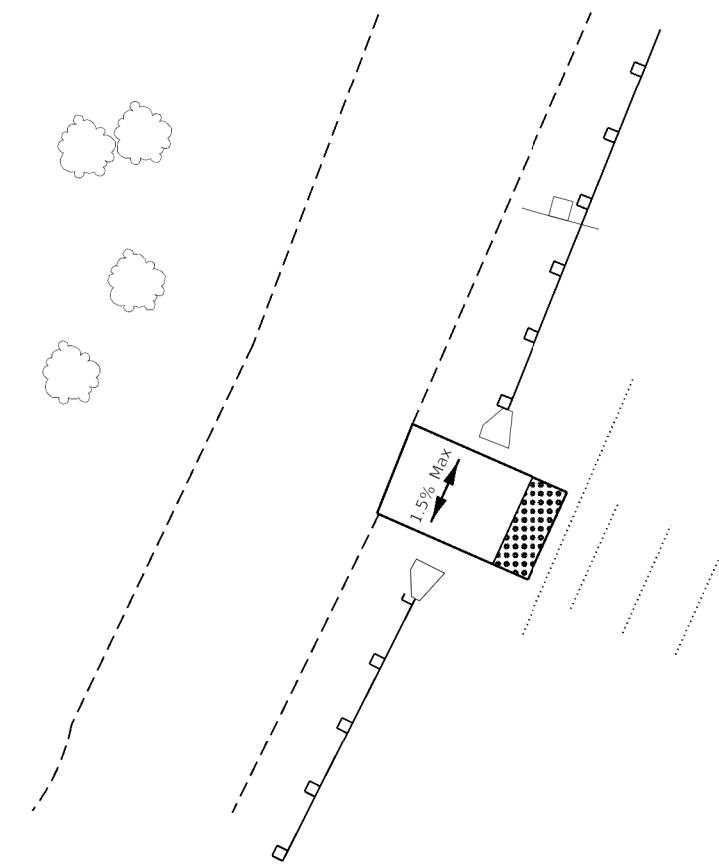

EARTH EXCAVATION TO OBTAIN GRADES IS INCLUDED IN THE COST PCC SIDEWALK 4 IN.

MODEL: Default
 FILE NAME: \\paul0848EBIDNITEG\illinois.gov\PWIDOT\Documents\DOT_Offices\District 3\Projects\ID366B38\CADD\1a\CAD\sheet\ID366B38_ADA.dwg

USER NAME = jeanjj	DESIGNED -	REVISED -
	DRAWN -	REVISED -
PLOT SCALE = 10.0000' / 1"	CHECKED -	REVISED -
PLOT DATE = 3/22/2018	DATE -	REVISED -

STATE OF ILLINOIS
DEPARTMENT OF TRANSPORTATION

ADA DETAILS RIVER BEND RD - NW QUAD			
SCALE:	SHEET 1	OF 4	SHEETS STA. TO STA.

F.A.U. RTE.	SECTION	COUNTY	TOTAL SHEETS	SHEET NO.
2503	(35)RS-4	KENDALL	19	10
ILLINOIS FED. AID PROJECT			CONTRACT NO. 66838	



NE QUAD

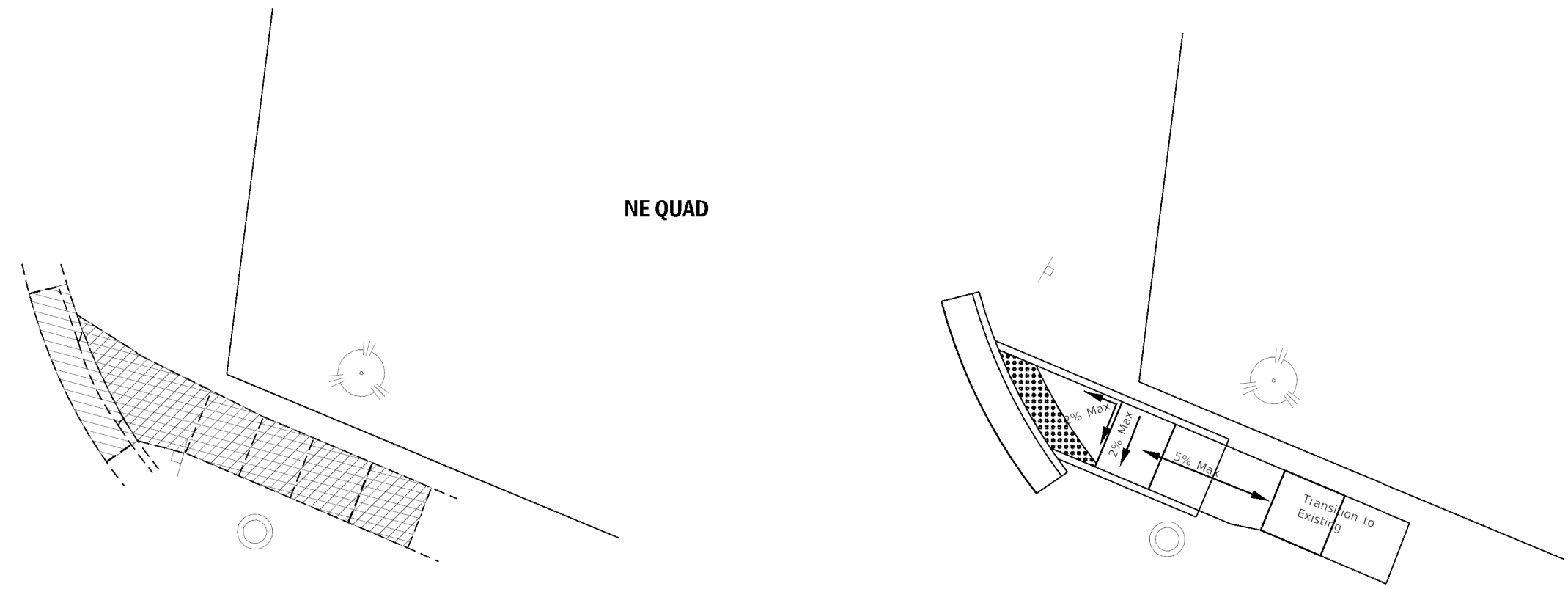

EARTH EXCAVATION TO OBTAIN GRADES IS INCLUDED IN THE COST PCC SIDEWALK 4 IN.

MODEL: Default
 FILE NAME: \\paul0848\BID\NITEG_IL\Illinois.gov\PW\DOT\Documents\DOT_Offices\District 3\Projects\ID366838\CADD\1a\CAD\sheet\ID366838_ADA_details.dgn

USER NAME = jeanjj	DESIGNED -	REVISED -
	DRAWN -	REVISED -
PLOT SCALE = 10.0000' / 1"	CHECKED -	REVISED -
PLOT DATE = 3/22/2018	DATE -	REVISED -

STATE OF ILLINOIS
DEPARTMENT OF TRANSPORTATION

ADA DETAILS			
RIVER BEND RD - NE QUAD			
SCALE:	SHEET 2	OF 4 SHEETS	STA. TO STA.

F.A.U. RTE.	SECTION	COUNTY	TOTAL SHEETS	SHEET NO.
2503	(35)RS-4	KENDALL	19	11
ILLINOIS FED. AID PROJECT			CONTRACT NO. 66838	

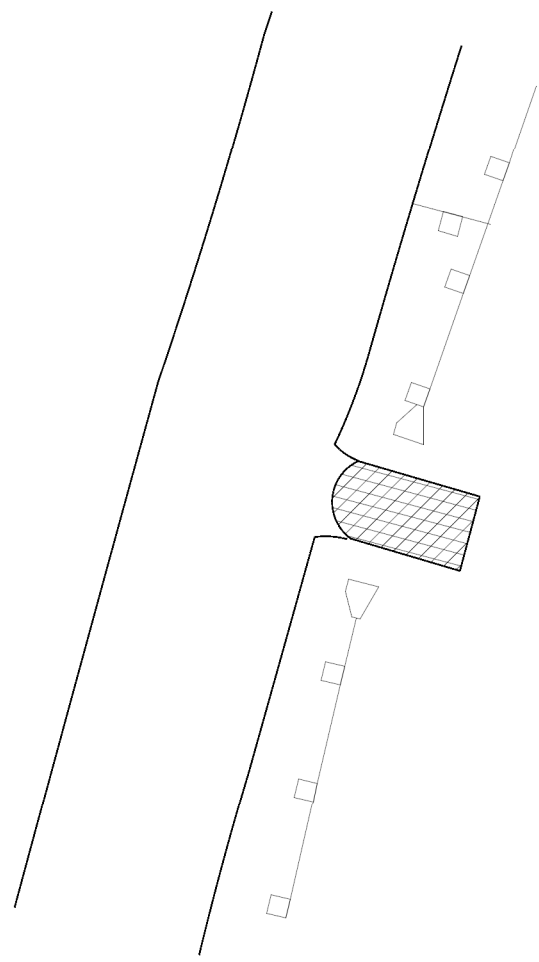

NW QUAD

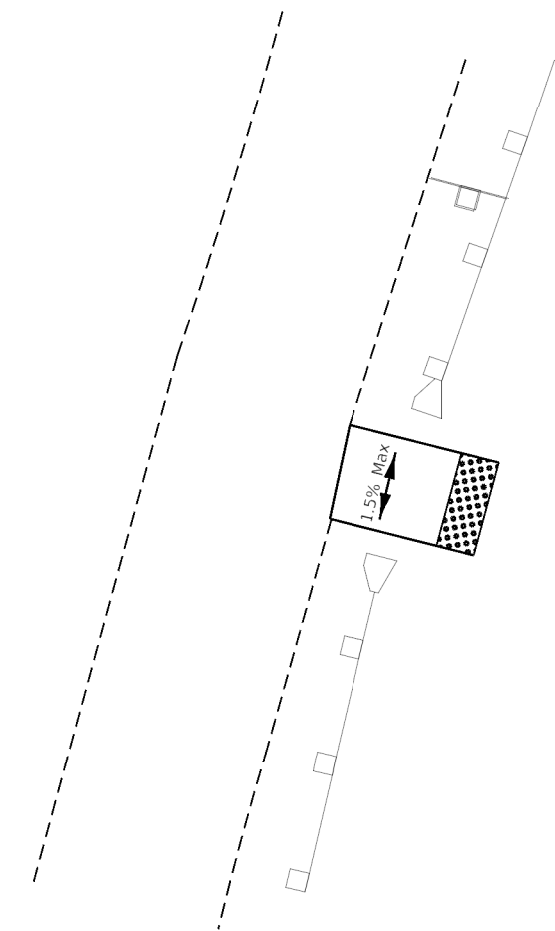

EARTH EXCAVATION TO OBTAIN GRADES IS INCLUDED IN THE COST PCC SIDEWALK 4 IN.

MODEL: Default
 FILE NAME: \\paul0848\BID\NITEG\Illinois.gov\PW\DOT\Documents\DOT_Offices\District 3\Projects\ID366838\CADD\1st\CAD\sheet\ID366838_ADA_detail.dgn

USER NAME = jeanjj	DESIGNED -	REVISED -
	DRAWN -	REVISED -
PLOT SCALE = 10.0000' / 1"	CHECKED -	REVISED -
PLOT DATE = 3/22/2018	DATE -	REVISED -

**STATE OF ILLINOIS
DEPARTMENT OF TRANSPORTATION**

ADA DETAILS NORTH BIKE PATH			
SCALE:	SHEET 3	OF 4 SHEETS	STA. TO STA.

F.A.U. RTE.	SECTION	COUNTY	TOTAL SHEETS	SHEET NO.
2503	(35)RS-4	KENDALL	19	12
			CONTRACT NO. 66838	
		ILLINOIS	FED. AID PROJECT	

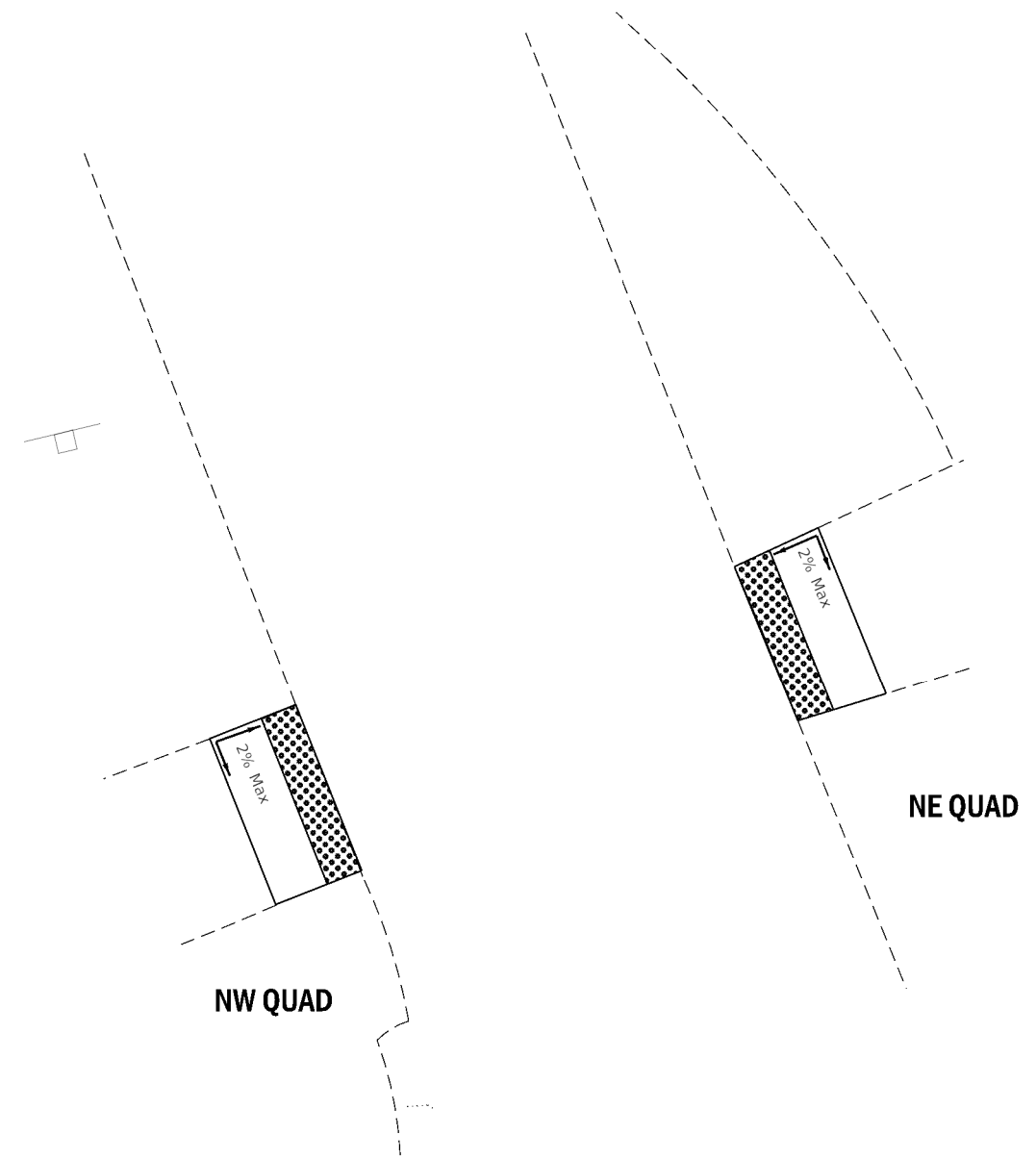
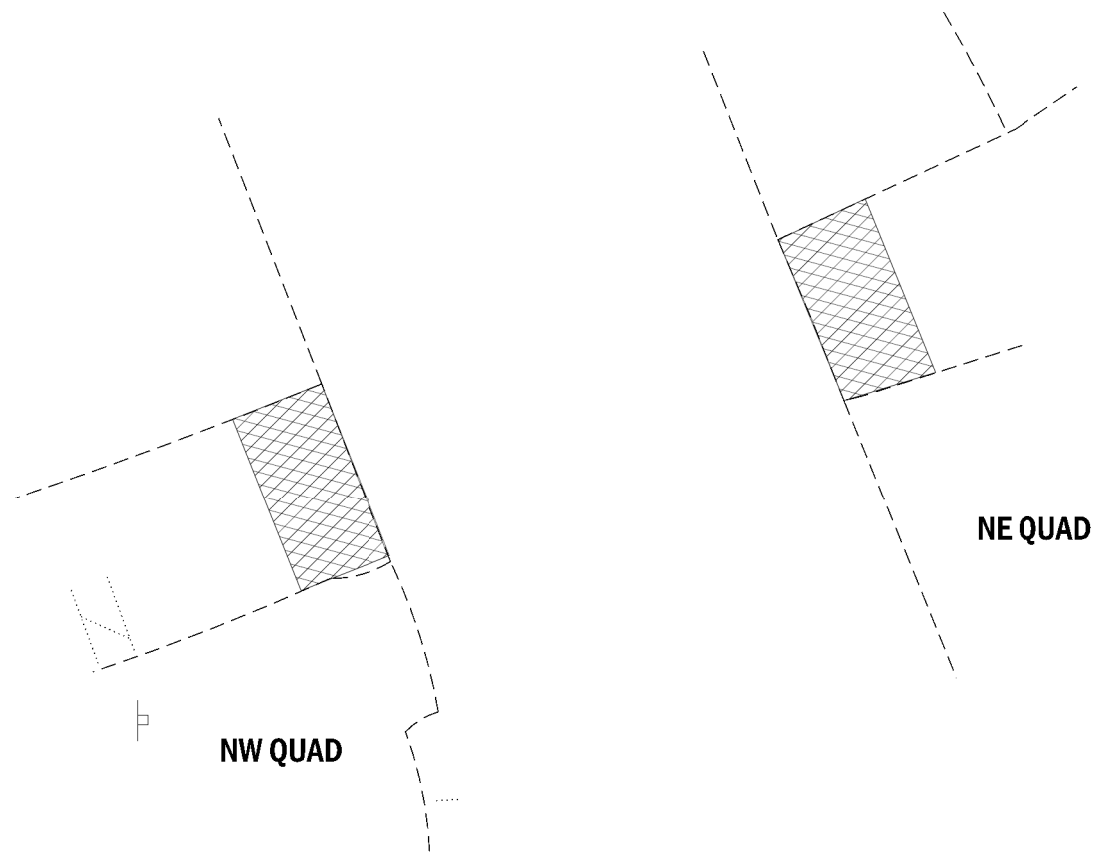

EARTH EXCAVATION TO OBTAIN GRADES IS INCLUDED IN THE COST PCC SIDEWALK 4 IN.

MODEL: Default
 FILE NAME: \\paul0848\BID\NITEG\Illinois.gov\PWIDOT\Documents\DOT_Offices\District 3\Projects\ID366838\CADD\1st\CAD\sheet\ID366838_ADA_detail.dgn

USER NAME = jeanjj	DESIGNED -	REVISED -
	DRAWN -	REVISED -
PLOT SCALE = 10.0000' / 1"	CHECKED -	REVISED -
PLOT DATE = 3/22/2018	DATE -	REVISED -

STATE OF ILLINOIS
DEPARTMENT OF TRANSPORTATION

ADA DETAILS VIOLET PATCH PARK			
SCALE:	SHEET 4	OF 4 SHEETS	STA. TO STA.

F.A.U. RTE.	SECTION	COUNTY	TOTAL SHEETS	SHEET NO.
2503	(35)RS-4	KENDALL	19	13
ILLINOIS FED. AID PROJECT			CONTRACT NO. 66838	

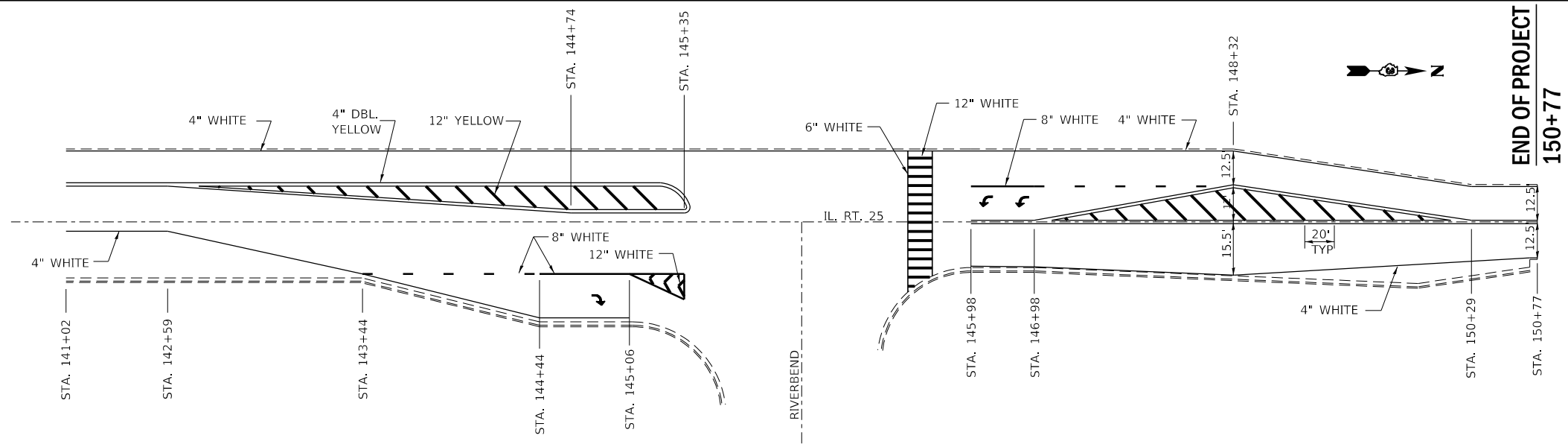

END OF PROJECT
150+77

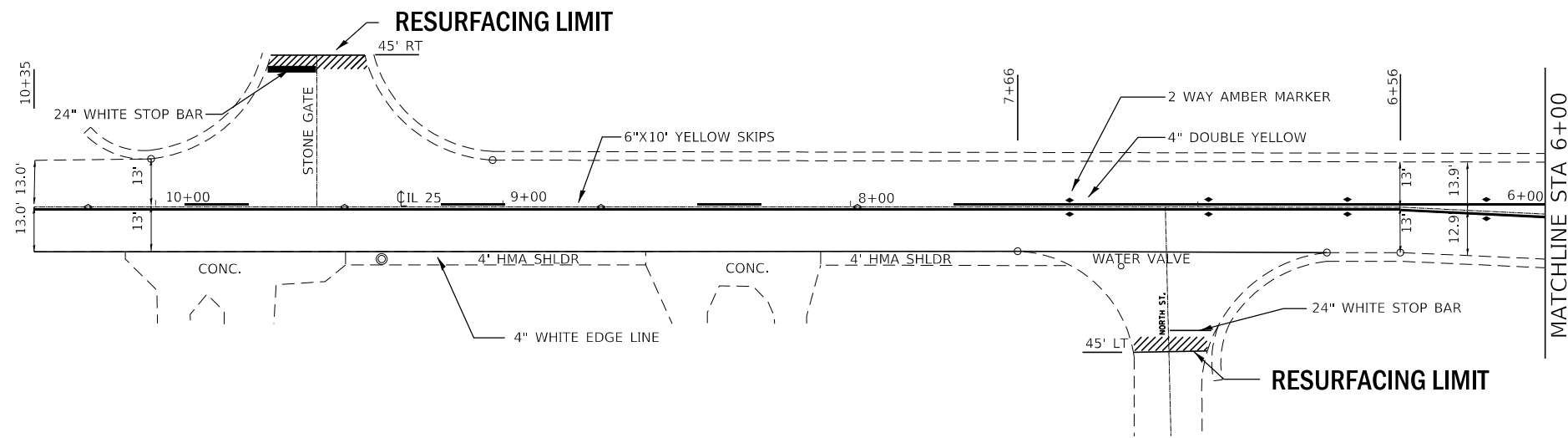

BEGINNING OF PROJECT
2+72

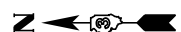
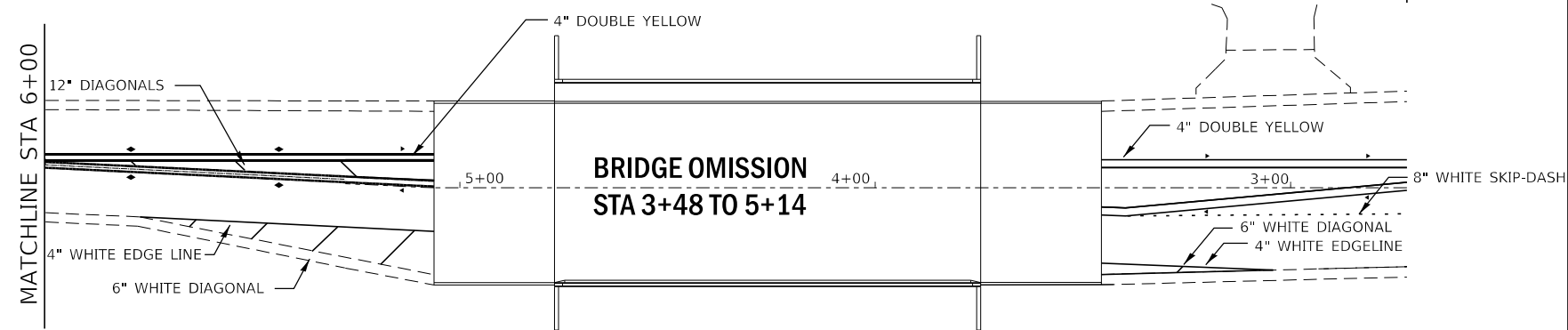

MODEL: Default
 FILE: \\mhc-pw\ulb\B&E\BID\ITEC\Illinois\gov\PIW\DOT\Documents\1\DOT_Offices\Director\3\Projects\0366838\CADD\data\CAD\ref\0366838-pts-deta11.dgn

USER NAME = jeanj	DESIGNED -	REVISED -
	DRAWN -	REVISED -
PLOT SCALE = 100,0000' / in.	CHECKED -	REVISED -
PLOT DATE = 3/22/2018	DATE -	REVISED -

STATE OF ILLINOIS
DEPARTMENT OF TRANSPORTATION

DETAILS

SCALE: SHEET 1 OF 6 SHEETS STA. TO STA.

F.A.U. RTE.	SECTION	COUNTY	TOTAL SHEETS	SHEET NO.
2503	(35)RS-4	KENDALL	19	14
CONTRACT NO. 66838				
ILLINOIS FED. AID PROJECT				

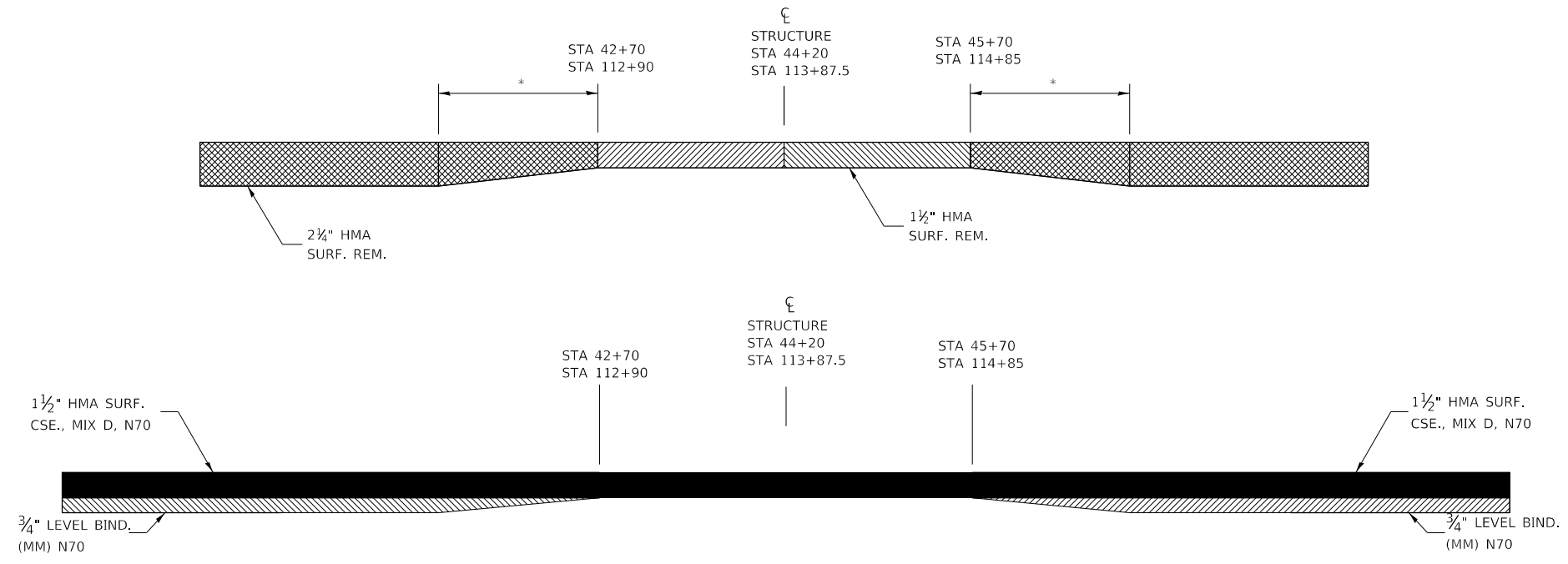

MILLING AND RESURFACING AT R.R. STRUCTURES

* HMA SURFACE REMOVAL, VARIABLE DEPTH

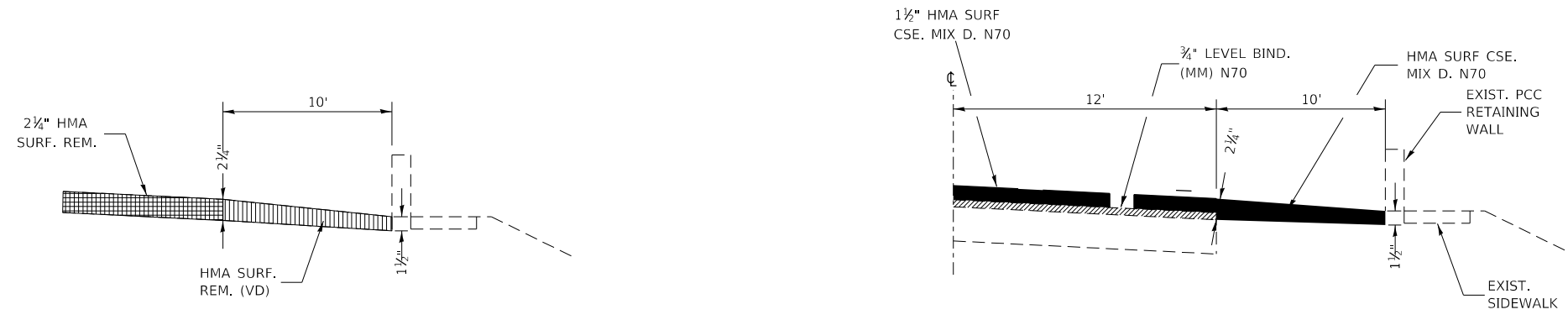

MILLING AND RESURFACING AT RETAINING WALL

STA. 137+16 TO STA. 141+30 LT

MODEL: Default
 FILE: h:\mhc\p\1108\EBID\NTEC\Illinois\gov\PIWDOT\Documents\110DOT_Offices\Director\3\Projects\0366838\CADD\data\CAD\sheet\0366838-sh2-detail.dgn

USER NAME = jeanj	DESIGNED -	REVISED -
	DRAWN -	REVISED -
PLOT SCALE = 100,0000' / in.	CHECKED -	REVISED -
PLOT DATE = 3/22/2018	DATE -	REVISED -

**STATE OF ILLINOIS
DEPARTMENT OF TRANSPORTATION**

DETAILS			
SCALE:	SHEET 2 OF 6 SHEETS	STA.	TO STA.

F.A.U. RTE.	SECTION	COUNTY	TOTAL SHEETS	SHEET NO.
2503	(35)RS-4	KENDALL	19	15
CONTRACT NO. 66838				
ILLINOIS FED. AID PROJECT				

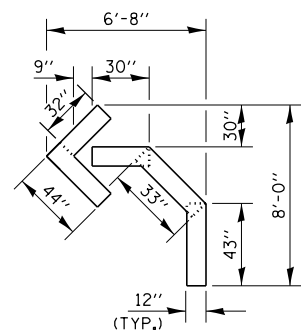

QUANTITY
12" LINE = 16 LIN FT
OR 4" LINE = 48 LIN FT

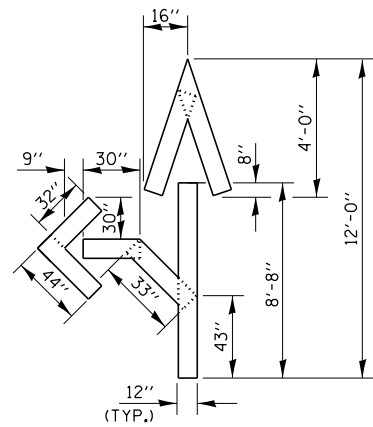

QUANTITY
12" LINE = 29 LIN FT
OR 4" LINE = 87 LIN FT

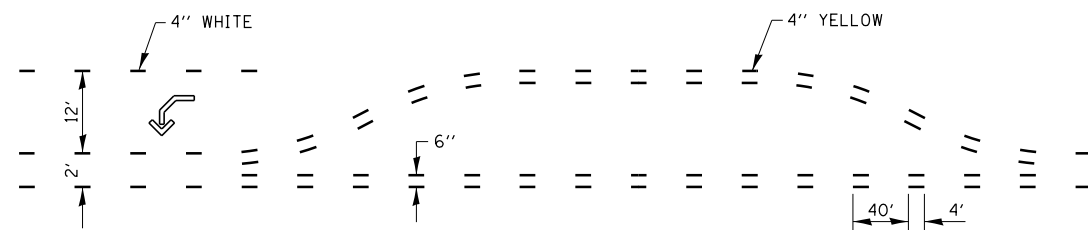

**SHORT-TERM PAVEMENT MARKING
FOR MEDIANS AND ARROWS**

703-1

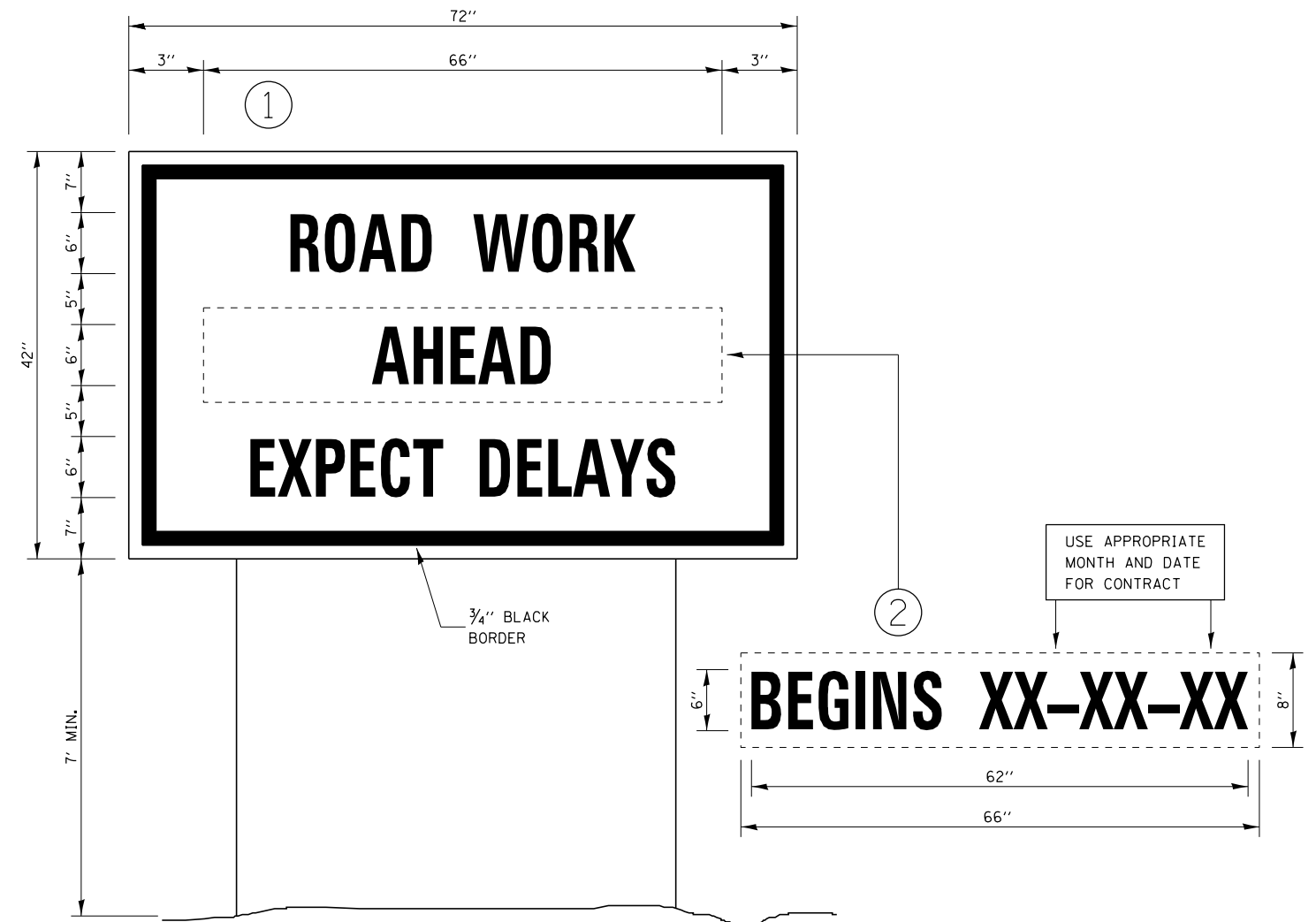

TEMPORARY INFORMATION SIGNING

NOTES:

1. USE 6" D BLACK LETTERING ON FLUORESCENT ORANGE BACKGROUND.
2. ERECT SIGNS AT LOCATIONS IN ADVANCE OF THE "ROAD CONSTRUCTION AHEAD" SIGNS AS DIRECTED BY THE ENGINEER.
3. ERECT SIGN ① WITH INSTALLED PANEL ② A MINIMUM OF ONE WEEK PRIOR TO THE START OF THE LANE CLOSURE.
4. REMOVE PANEL ② ON THAT DATE.
5. SEE SPECIAL PROVISION "TEMPORARY INFORMATION SIGNING" FOR ADDITIONAL INFORMATION.
6. WILL BE PAID FOR PER SQ FT AS "TEMPORARY INFORMATION SIGNING". EACH SIGN = 21 SQ FT AND THE DATE PANEL ② WILL NOT BE MEASURED SEPARATELY FOR PAYMENT.

720-8

MODEL: Default
FILE: \\nas0101\B&E\BID\NTEC\Illinois\gov\PI\DOT\Documents\1\DOT_Offices\Director\3\Projects\0366838\CAD\Drawings\0366838-01.dwg

USER NAME = jeanj	DESIGNED -	REVISED -
	DRAWN -	REVISED -
PLOT SCALE = 100.0000' / in.	CHECKED -	REVISED -
PLOT DATE = 3/22/2018	DATE -	REVISED -

**STATE OF ILLINOIS
DEPARTMENT OF TRANSPORTATION**

DETAILS

SCALE: SHEET 4 OF 6 SHEETS STA. TO STA.

F.A.U. RTE.	SECTION	COUNTY	TOTAL SHEETS	SHEET NO.
2503	(35)RS-4	KENDALL	19	17
CONTRACT NO. 66838				
ILLINOIS FED. AID PROJECT				

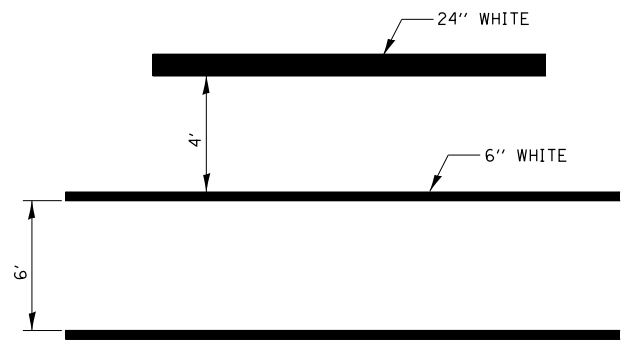

**TYPICAL SPACING DETAIL FOR
CROSSWALKS AND STOP BARS**

**780-3
OPTION 1**

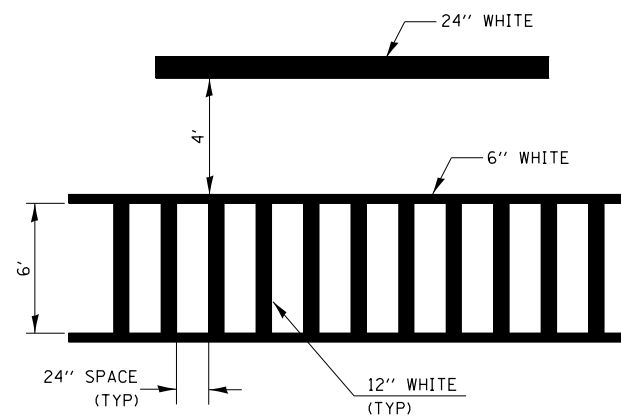

**TYPICAL SPACING DETAIL FOR
CROSSWALKS AND STOP BARS**

**780-3
OPTION 2**

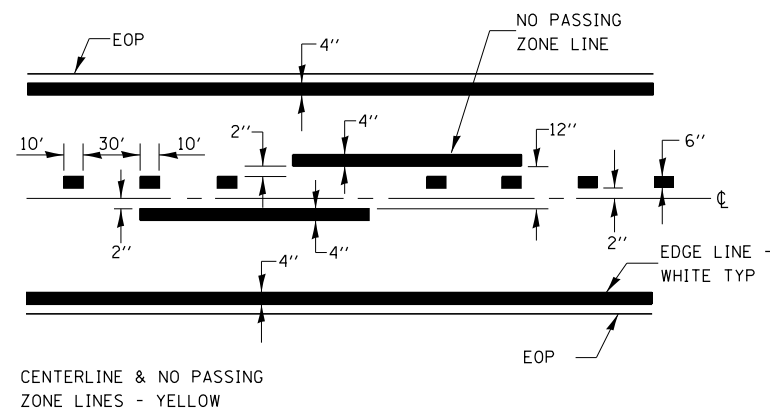

PAVEMENT MARKING

780-8

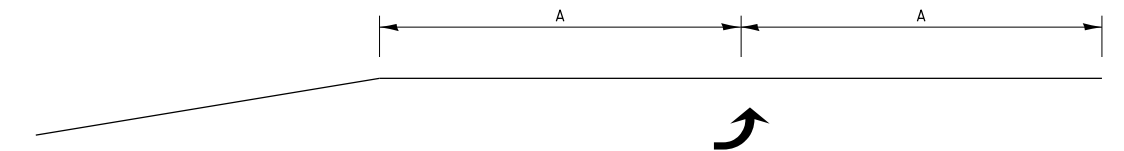

99' AND UNDER

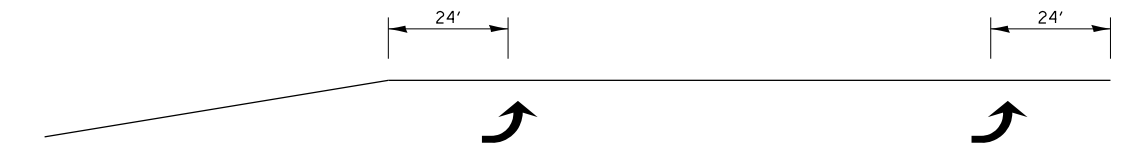

100' TO 149'

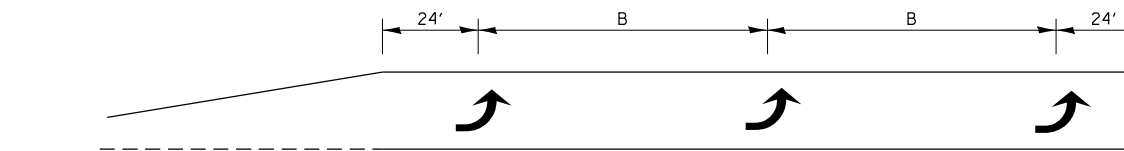

150' AND LONGER

**TYPICAL PLACEMENT OF ARROWS
IN TURN LANES**

780-10

URBAN PAVEMENT MARKING

MODEL: Default
 FILE: \\nas01c.pva\illinois\B&E\BID\NTEC\Illinois\pva\pvd\DOT\Documents\1\DOT - Office\1\100366838\CADD\data\CAD\pva\pvd\DOT - Office\1\100366838\pva\pvd\DOT - Office\1\100366838.dwg

USER NAME = jeanj	DESIGNED -	REVISED -
PLOT SCALE = 100.0000' / in.	DRAWN -	REVISED -
PLOT DATE = 3/22/2018	CHECKED -	REVISED -
	DATE -	REVISED -

**STATE OF ILLINOIS
DEPARTMENT OF TRANSPORTATION**

SCALE:	SHEET 5 OF 6 SHEETS	STA.	TO STA.
--------	---------------------	------	---------

F.A.U. RTE.	SECTION	COUNTY	TOTAL SHEETS	SHEET NO.
2503	(35)RS-4	KENDALL	19	18
CONTRACT NO. 66838				
ILLINOIS FED. AID PROJECT				

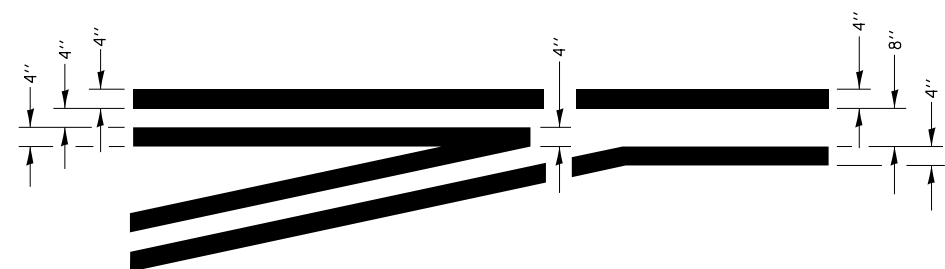
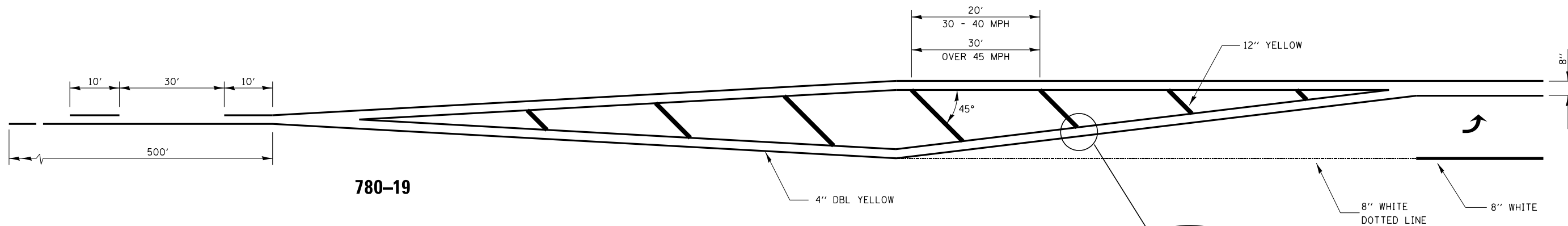

**TYPICAL APPLICATION
LEFT TURN LANES**

780-1

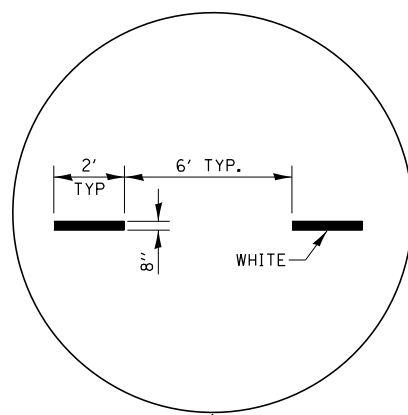

**ADVANCE AND INTERSECTION LANE
DIVIDER LINES**

780-5

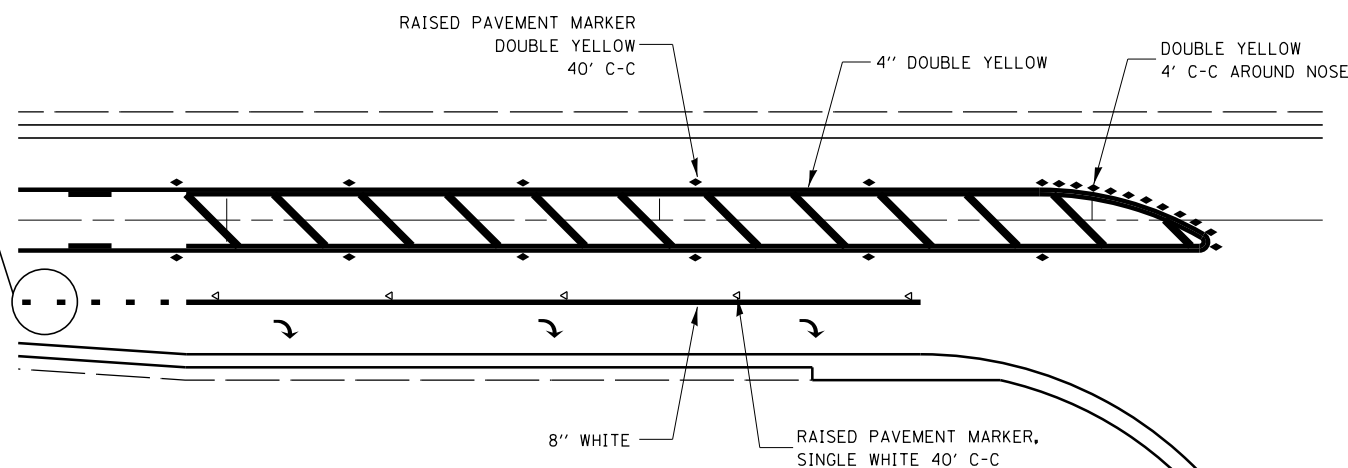

**RAISED REFLECTIVE AND PAVEMENT MARKERS
RIGHT TURN LANE**

781-1

URBAN PAVEMENT MARKING

MODEL: Default
 FILE: \\nas01.psu.edu\BEBIDN\TEC\Illinois\gov\PI\DOT\Documents\1\DOT_Offices\DI\refct_3\Projects\0366838\CADD\data\CAD\refct\0366838-4b-draw11.dgn

USER NAME = jeanj	DESIGNED -	REVISED -
PLOT SCALE = 100,0000 ' / in.	DRAWN -	REVISED -
PLOT DATE = 3/22/2018	CHECKED -	REVISED -
	DATE -	REVISED -

**STATE OF ILLINOIS
DEPARTMENT OF TRANSPORTATION**

DETAILS	
SCALE:	SHEET 6 OF 6 SHEETS STA. TO STA.

F.A.U. RTE.	SECTION	COUNTY	TOTAL SHEETS	SHEET NO.
2503	(35)RS-4	KENDALL	19	19
CONTRACT NO. 66838				
ILLINOIS FED. AID PROJECT				