

To McDonough St. bridge control system ethernet switch drawing 05-026

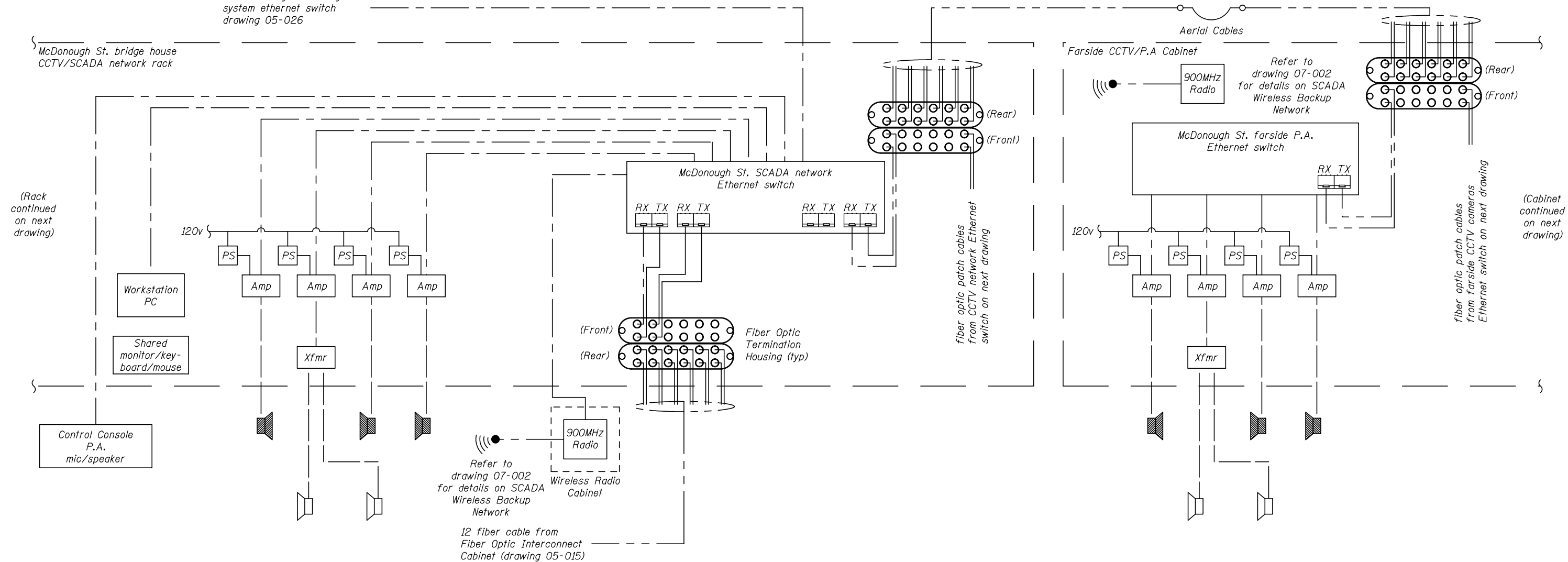

PUBLIC ADDRESS SYSTEMS EQUIPMENT		
Item No.	Quantity	Item Description
1	1	Rack mount workstation computer
2	1	Monitor, pointer, and keyboard for computer
3	1	Console microphone/speaker and accessories
4	8	Amplifier power supply
5	8	Network speaker amplifier
6	2	One-way speaker transformer
7	6	Two-way outdoor speaker
8	4	One-way outdoor speaker
9	10	Speaker surge protection
10	as req.	Circuit breaker
11	2	Surge Protective Device
12	1	24VDC power supply
13	1	Industrial Ethernet switch
14	1	Utility receptacle
15	as req.	Accessories and installation hardware

WIRELESS BACKUP NETWORK EQUIPMENT		
Item No.	Quantity	Item Description
1*	4	900 MHz Ethernet radio
2*	4	900 MHz antenna with installation hardware & accessories
3**	1	2.4 GHz Ethernet Radio
4**	3	2.4 GHz antenna with installation hardware & accessories
5	7	Antenna surge suppressor
6	5	Surge Protective Device
7	5	Circuit breaker
8	5	24VDC power supply/UPS
9	as req.	Accessories and installation hardware
10	1	Wireless Radio Cabinet

SCADA SYSTEM EQUIPMENT		
Item No.	Quantity	Item Description
1	1	CCTV/SCADA network rack
2	1	Rack mounted UPS (Uninterruptible Power Supply)
3	1	SCADA network Ethernet switch
4	4	Rack mount fiber termination housings, 12 position
5	as req.	Rack accessories and hardware

**LEGEND**

- Speaker wire connection
- Fiber optic connection
- - - - - Cat6 ethernet connection
- Power connection
- Video / Comm connection
- ▒ Two-way speaker
- One-way speaker
- (((• Wireless network antenna

\* 2 Radio and 2 antenna for CCTV wireless system, shown on drawing 05-016  
 \*\* Radio and antennas for CCTV wireless system, shown on this drawing 05-016.

**NOTES:**

1. These equipment schedules are provided for reference and do not provide an exhaustive listing of all equipment required.
2. The Contractor shall be responsible for developing a complete bill of materials of equipment required.



USER NAME =	DESIGNED - R.I. PETERS	REVISED _____
	CHECKED - L.V. BORDEN	REVISED _____
PLOT SCALE =	DRAWN - R.I. PETERS	REVISED _____
PLOT DATE =	CHECKED - K.M. GABLE	REVISED _____

STATE OF ILLINOIS  
DEPARTMENT OF TRANSPORTATION

VARIOUS MOVABLE BRIDGES  
LOCAL CENTRALIZED CONTROL AND OPERATION  
MCDONOUGH STREET - SCADA ONE-LINE

SHEET NO. 16 OF 40 SHEETS

McDONOUGH, Drawing 05-016				
F.A.U. RTE.	SECTION	COUNTY	TOTAL SHEETS	SHEET NO.
0313	2011-045-1	WILL	466	301
CONTRACT NO. 60P55				

ILLINOIS FED. AID PROJECT

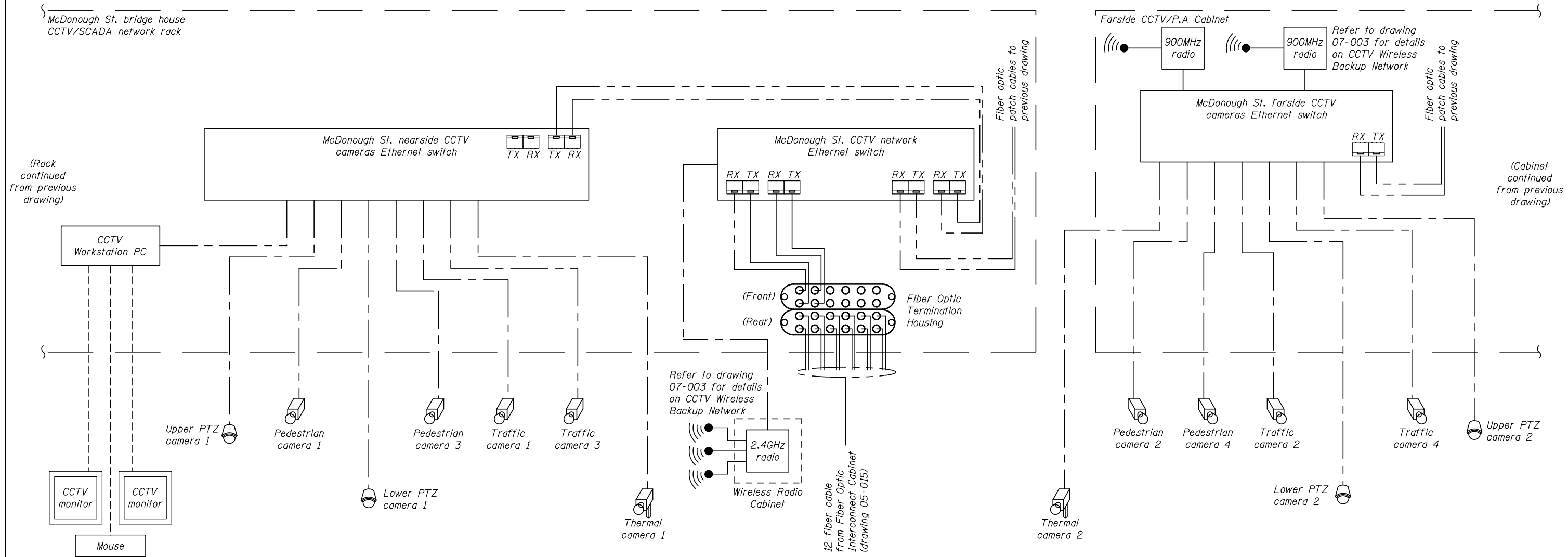

**LEGEND**

- Fiber optic connection
- Cat6 connection
- Power connection
- Video / Comm connection
- Pan-tilt-zoom (PTZ) camera
- Pan-tilt thermal camera
- Fixed camera
- Wireless Network Antenna

BRIDGE CONTROL CCTV SYSTEM EQUIPMENT		
Item No.	Quantity	Item Description
1	1	Rack mounted UPS (Uninterruptible Power Supply)
2	1	CCTV network Ethernet switch
3	1	Nearside CCTV camera Ethernet switch
4	4	Rack mount fiber termination housings, 12 position
5	1	CCTV Workstation PC
6	1	Mouse / pointer
7	2	31.5" 1080p video monitor
8	4	Pan-Tilt-Zoom CCTV camera with lens, enclosure, and accessories
9	2	Pan-Tilt Thermal CCTV camera with lens, enclosure, accessories
10	8	Fixed CCTV camera with lens, enclosure, accessories
11	14	CCTV ethernet surge protection
12	as req.	Camera power supplies
13	as req.	camera circuit breakers
14	as req.	POE (Power Over Ethernet) converters

BRIDGE CONTROL CCTV SYSTEM EQUIPMENT (continued)		
Item No.	Quantity	Item Description
15	1	Farside Cabinet for CCTV and public address equipment with equipment & accessories
16	2	Surge Protective Device
17	1	Industrial cabinet UPS
18	1	24VDC power supply
19	1	Industrial Ethernet switch
20	1	Cabinet mount fiber termination housing, 12 position

**NOTES:**

- These equipment schedules are provided for reference and do not provide an exhaustive listing of all equipment required.
- The Contractor shall be responsible for developing a complete bill of materials of equipment required.



USER NAME =	DESIGNED - R.I. PETERS	REVISED -
	CHECKED - L.V. BORDEN	REVISED -
PLOT SCALE =	DRAWN - R.I. PETERS	REVISED -
PLOT DATE =	CHECKED - K.M. GABLE	REVISED -

**STATE OF ILLINOIS  
DEPARTMENT OF TRANSPORTATION**

**VARIOUS MOVABLE BRIDGES  
LOCAL CENTRALIZED CONTROL AND OPERATION  
MCDONOUGH STREET - CCTV ONE-LINE**

SHEET NO. 17 OF 40 SHEETS

McDONOUGH, Drawing 05-017			
F.A.U. RTE.	SECTION	COUNTY	TOTAL SHEETS SHEET NO.
0313	2011-045-I	WILL	466 302
			CONTRACT NO. 60P55

ILLINOIS FED. AID PROJECT



MCDONOUGH ST. PEDESTRIAN CAMERA 1	
Camera type	Fixed pedestrian
Focal length (mm.)*	4.4-132mm (30x zoom)
Camera height (ft.)	40 ft
Camera tilt (°)	-5°

MCDONOUGH ST. PEDESTRIAN CAMERA 2	
Camera type	Fixed pedestrian
Focal length (mm.)*	4.4-132mm (30x zoom)
Camera height (ft.)	40 ft
Camera tilt (°)	-5°

MCDONOUGH ST. PEDESTRIAN CAMERA 3	
Camera type	Fixed pedestrian
Focal length (mm.)*	4.4-132mm (30x zoom)
Camera height (ft.)	40 ft
Camera tilt (°)	-5°

MCDONOUGH ST. PEDESTRIAN CAMERA 4	
Camera type	Fixed pedestrian
Focal length (mm.)*	4.4-132mm (30x zoom)
Camera height (ft.)	40 ft
Camera tilt (°)	-5°

Camera height is based off of pool elevation (EL. +539.91). Location and camera height are approximate. See 'CCTV Plan and Elevation' drawings for mounting details. Camera positioning to be field adjusted at each location.

\*Zoom lens focal length shall be field adjusted to the desired field of view.



USER NAME =	DESIGNED - K.M. GABLE	REVISED	---
	CHECKED - L.V. BORDEN	REVISED	---
PLOT SCALE =	DRAWN - R.L. REED	REVISED	---
PLOT DATE =	CHECKED - R.I. PETERS	REVISED	---

STATE OF ILLINOIS  
DEPARTMENT OF TRANSPORTATION

VARIOUS MOVABLE BRIDGES  
LOCAL CENTRALIZED CONTROL AND OPERATION  
MCDONOUGH STREET - PEDESTRIAN CAMERA LAYOUT  
SHEET NO. 18 OF 40 SHEETS

F.A.U. RTE.	SECTION	COUNTY	TOTAL SHEETS	SHEET NO.
0313	2011-045-I	WILL	466	303
CONTRACT NO. 60P55				
ILLINOIS FED. AID PROJECT				

McDONOUGH, Drawing 05-018



MCDONOUGH ST. TRAFFIC CAMERA 1	
Camera type	Fixed traffic
Focal length (mm.)*	4.4-132mm (30x zoom)
Camera height (ft.)	60 ft
Camera tilt (°)	-15°

MCDONOUGH ST. TRAFFIC CAMERA 2	
Camera type	Fixed traffic
Focal length (mm.)*	4.4-132mm (30x zoom)
Camera height (ft.)	60 ft
Camera tilt (°)	-20°

MCDONOUGH ST. TRAFFIC CAMERA 3	
Camera type	Fixed traffic
Focal length (mm.)*	4.4-132mm (30x zoom)
Camera height (ft.)	60 ft
Camera tilt (°)	-10°

MCDONOUGH ST. TRAFFIC CAMERA 4	
Camera type	Fixed traffic
Focal length (mm.)*	4.4-132mm (30x zoom)
Camera height (ft.)	60 ft
Camera tilt (°)	-10°

Camera height is based off of pool elevation (EL. +539.91). Location and camera height are approximate. See 'CCTV Plan and Elevation' drawings for mounting details. Camera positioning to be field adjusted at each location.

\*Zoom lens focal length shall be field adjusted to the desired field of view.



USER NAME =	DESIGNED - K.M. GABLE	REVISED	___
	CHECKED - L.V. BORDEN	REVISED	___
PLOT SCALE =	DRAWN - R.L. REED	REVISED	___
PLOT DATE =	CHECKED - R.I. PETERS	REVISED	___

STATE OF ILLINOIS  
DEPARTMENT OF TRANSPORTATION

VARIOUS MOVABLE BRIDGES  
LOCAL CENTRALIZED CONTROL AND OPERATION  
MCDONOUGH STREET - TRAFFIC CAMERA LAYOUT

SHEET NO. 19 OF 40 SHEETS

F.A.U. RTE.	SECTION	COUNTY	TOTAL SHEETS	SHEET NO.
0313	2011-045-I	WILL	466	304
CONTRACT NO. 60P55				
ILLINOIS FED. AID PROJECT				

McDONOUGH, Drawing 05-019



MCDONOUGH ST. UPPER PTZ CAMERA 1	
Camera type	Upper PTZ
Focal length (mm.)	4.4-132mm (30x zoom)
Camera height (ft.)	30 ft
Camera tilt (°)	-90° to 5°

MCDONOUGH ST. UPPER PTZ CAMERA 2	
Camera type	Upper PTZ
Focal length (mm.)	4.4-132mm (30x zoom)
Camera height (ft.)	30 ft
Camera tilt (°)	-90° to 5°



**NOTES:**

1. Camera field of view is shown for illustration purposes and is adjustable as required.
2. Camera height is based off of pool elevation (EL. +539.91). Location and camera height are approximate. See 'CCTV Plan and Elevation' drawings for mounting details. Camera positioning to be field adjusted at each location.



USER NAME =	DESIGNED - K.M. GABLE	REVISED	___
	CHECKED - L.V. BORDEN	REVISED	___
PLOT SCALE =	DRAWN - R.L. REED	REVISED	___
PLOT DATE =	CHECKED - R.I. PETERS	REVISED	___

**STATE OF ILLINOIS  
DEPARTMENT OF TRANSPORTATION**

**VARIOUS MOVABLE BRIDGES  
LOCAL CENTRALIZED CONTROL AND OPERATION  
MCDONOUGH STREET - UPPER PTZ CAMERA LAYOUT**

SHEET NO. 20 OF 40 SHEETS

F.A.U. RTE.	SECTION	COUNTY	TOTAL SHEETS	SHEET NO.
0313	2011-045-I	WILL	466	305
CONTRACT NO. 60P55				

McDONOUGH, Drawing 05-020

ILLINOIS FED. AID PROJECT



MCDONOUGH ST. THERMAL CAMERA 1	
Camera type	Lower thermal (pan & tilt)
Focal length (mm.)	35 mm
Camera height (ft.)	9 ft
Camera tilt (°)	0°

MCDONOUGH ST. THERMAL CAMERA 2	
Camera type	Lower thermal (pan & tilt)
Focal length (mm.)	35 mm
Camera height (ft.)	9 ft
Camera tilt (°)	0°



Camera height is based off of pool elevation (EL. +539.91). Location and camera height are approximate. See 'CCTV Plan and Elevation' drawings for mounting details. Camera positioning to be field adjusted at each location.

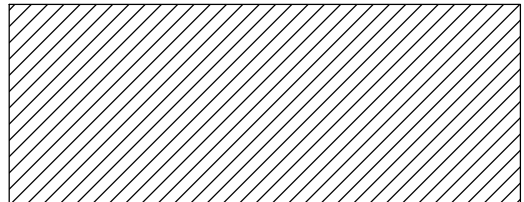

Human Identification\*  
(26 vertical Pixels on Target)

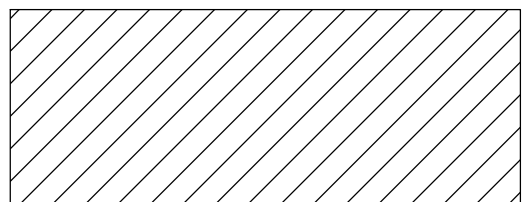

Human Recognition\*  
(8 vertical Pixels on Target)

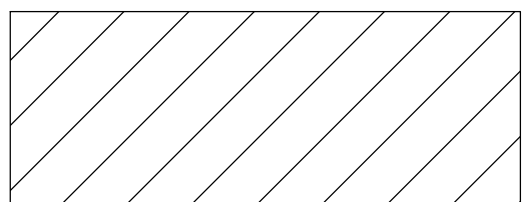

Human Detection\*  
(2 vertical Pixels on Target)

\*Viewing distance criteria based on image resolution of 640x480 (VGA format)



USER NAME =	DESIGNED - K.M. GABLE	REVISED	___
	CHECKED - L.V. BORDEN	REVISED	___
PLOT SCALE =	DRAWN - R.L. REED	REVISED	___
PLOT DATE =	CHECKED - R.I. PETERS	REVISED	___

STATE OF ILLINOIS  
DEPARTMENT OF TRANSPORTATION

VARIOUS MOVABLE BRIDGES  
LOCAL CENTRALIZED CONTROL AND OPERATION  
MCDONOUGH STREET - THERMAL CAMERA LAYOUT

SHEET NO. 21 OF 40 SHEETS

McDONOUGH, Drawing 05-021				
F.A.U. RTE.	SECTION	COUNTY	TOTAL SHEETS	SHEET NO.
0313	2011-045-I	WILL	466	306
CONTRACT NO. 60P55				
ILLINOIS FED. AID PROJECT				



MCDONOUGH ST. LOWER PTZ CAMERA 1	
Camera type	Lower PTZ
Focal length (mm.)	4.4-132mm (30x zoom)
Camera height (ft.)	9 ft
Camera tilt (°)	0° (at rest)

MCDONOUGH ST. LOWER PTZ CAMERA 2	
Camera type	Lower PTZ
Focal length (mm.)	4.4-132mm (30x zoom)
Camera height (ft.)	9 ft
Camera tilt (°)	0° (at rest)



**NOTES:**

1. Camera field of view shown for illustration purposes and is adjustable as required.
2. Camera height is based off of pool elevation (EL. +539.91). Location and camera height are approximate. See 'CCTV Plan and Elevation' drawings for mounting details. Camera positioning to be field adjusted at each location.



USER NAME =	DESIGNED - K.M. GABLE	REVISED	___
	CHECKED - L.V. BORDEN	REVISED	___
PLOT SCALE =	DRAWN - R.L. REED	REVISED	___
PLOT DATE =	CHECKED - R.I. PETERS	REVISED	___

**STATE OF ILLINOIS  
DEPARTMENT OF TRANSPORTATION**

**VARIOUS MOVABLE BRIDGES  
LOCAL CENTRALIZED CONTROL AND OPERATION  
McDONOUGH STREET - LOWER PTZ CAMERA LAYOUT**

SHEET NO. 22 OF 40 SHEETS

McDONOUGH, Drawing 05-022				
F.A.U. RTE.	SECTION	COUNTY	TOTAL SHEETS	SHEET NO.
0313	2011-045-I	WILL	466	307
CONTRACT NO. 60P55				
ILLINOIS FED. AID PROJECT				

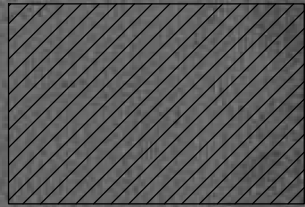
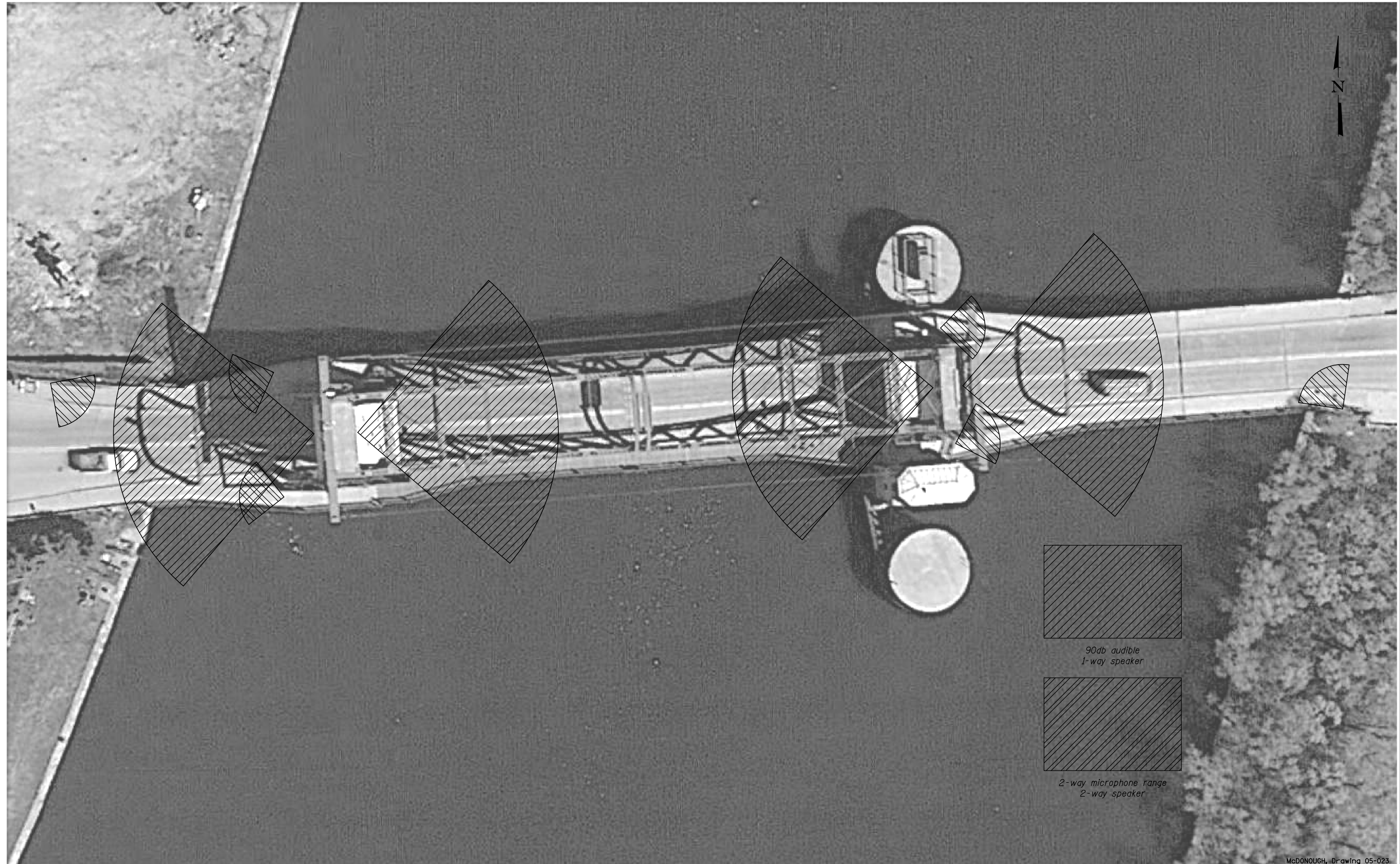

90db audible  
1-way speaker

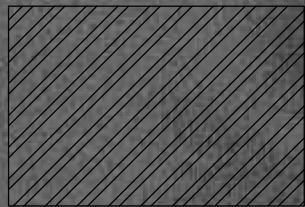

2-way microphone range  
2-way speaker



USER NAME =	DESIGNED - K.M. GABLE	REVISED	---
	CHECKED - L.V. BORDEN	REVISED	---
PLOT SCALE =	DRAWN - R.L. REED	REVISED	---
PLOT DATE =	CHECKED - R.I. PETERS	REVISED	---

**STATE OF ILLINOIS  
DEPARTMENT OF TRANSPORTATION**

**VARIOUS MOVABLE BRIDGES  
LOCAL CENTRALIZED CONTROL AND OPERATION  
McDONOUGH STREET - P.A. SPEAKER LAYOUT**

SHEET NO. 23 OF 40 SHEETS

F.A.U. RTE.	SECTION	COUNTY	TOTAL SHEETS	SHEET NO.
0313	2011-045-I	WILL	466	308
ILLINOIS FED. AID PROJECT			CONTRACT NO. 60P55	

McDONOUGH, Drawing 05-023



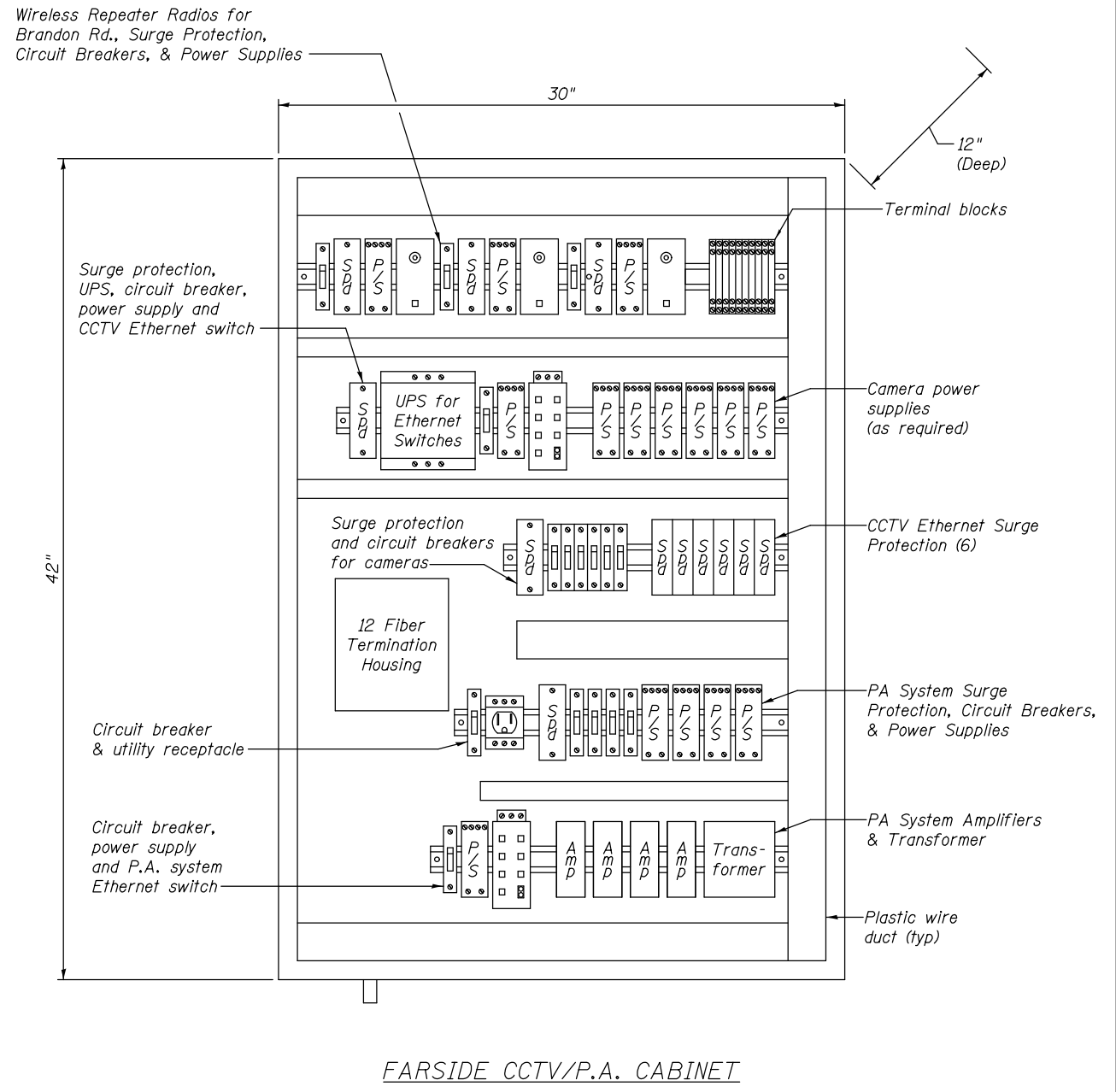
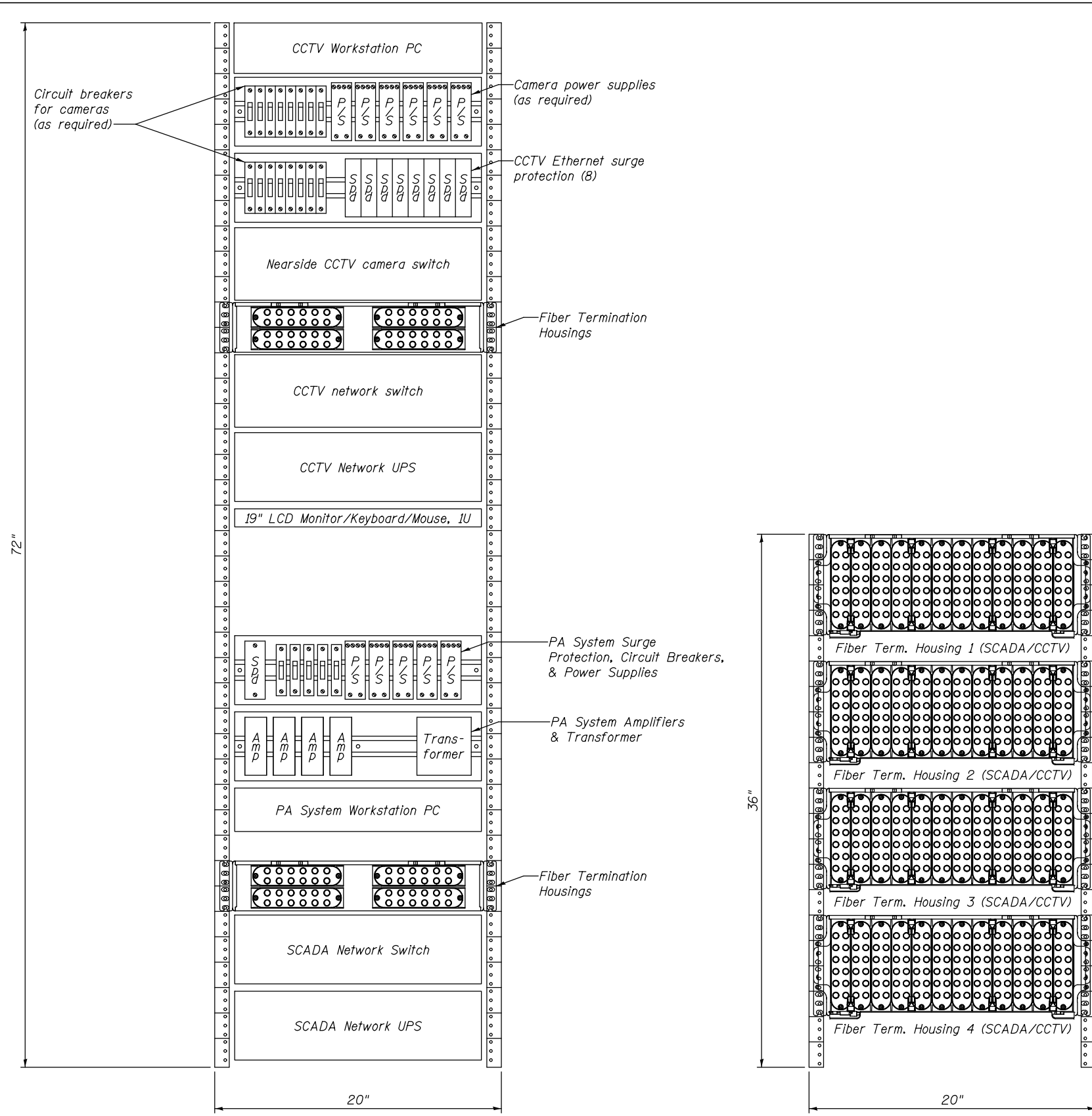

- NOTES:**
- Rack and cabinet layouts shown are conceptual. The Contractor shall be responsible for developing and submitting layouts with all required components.
  - The Systems Integrator shall be responsible for coordinating cabinet sizing requirements to accommodate equipment serving all applicable systems.



USER NAME =	DESIGNED - R.I. PETERS	REVISED -
	CHECKED - L.V. BORDEN	REVISED -
PLOT SCALE =	DRAWN - R.I. PETERS	REVISED -
PLOT DATE =	CHECKED - K.M. GABLE	REVISED -

STATE OF ILLINOIS  
DEPARTMENT OF TRANSPORTATION

VARIOUS MOVABLE BRIDGES  
LOCAL CENTRALIZED CONTROL AND OPERATION  
MCDONOUGH STREET - NETWORK CABINET DETAILS  
SHEET NO. 24 OF 40 SHEETS

McDONOUGH, Drawing 05-024

F.A.U. RTE.	SECTION	COUNTY	TOTAL SHEETS	SHEET NO.
0313	2011-045-I	WILL	466	309

CONTRACT NO. 60P55  
ILLINOIS FED. AID PROJECT

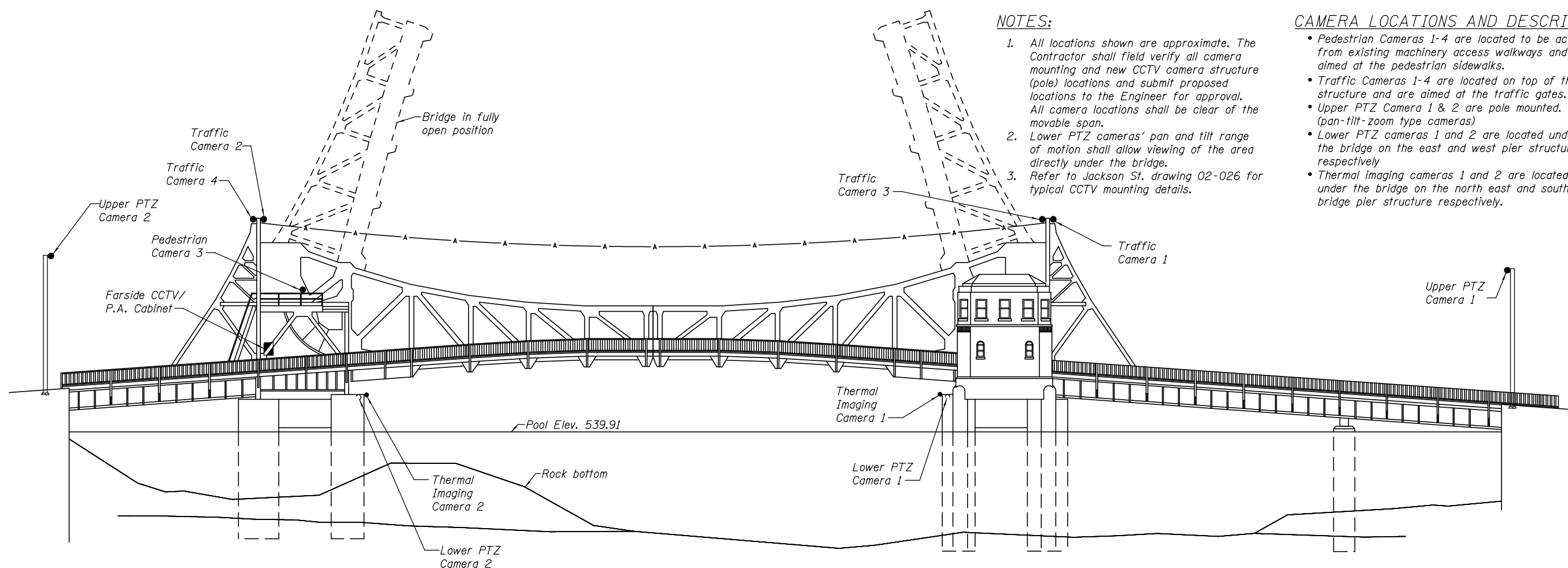

ELEVATION

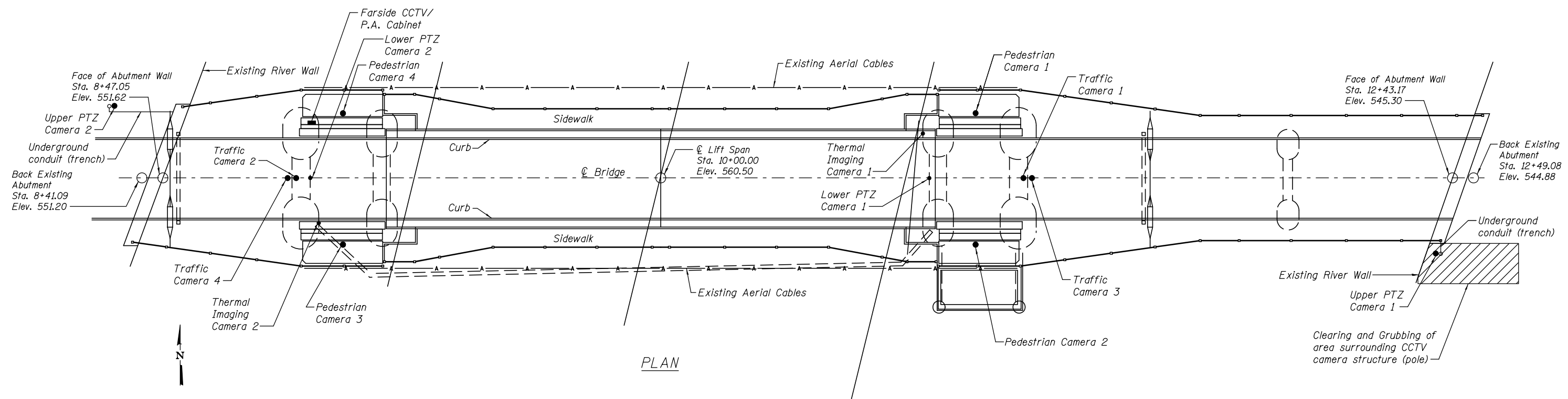

PLAN

NOTES:

1. All locations shown are approximate. The Contractor shall field verify all camera mounting and new CCTV camera structure (pole) locations and submit proposed locations to the Engineer for approval. All camera locations shall be clear of the movable span.
2. Lower PTZ cameras' pan and tilt range of motion shall allow viewing of the area directly under the bridge.
3. Refer to Jackson St. drawing 02-026 for typical CCTV mounting details.

CAMERA LOCATIONS AND DESCRIPTIONS

- Pedestrian Cameras 1-4 are located to be accessible from existing machinery access walkways and are aimed at the pedestrian sidewalks.
- Traffic Cameras 1-4 are located on top of the fixed span structure and are aimed at the traffic gates.
- Upper PTZ Camera 1 & 2 are pole mounted. (pan-tilt-zoom type cameras)
- Lower PTZ cameras 1 and 2 are located under the bridge on the east and west pier structure respectively
- Thermal imaging cameras 1 and 2 are located under the bridge on the north east and south west bridge pier structure respectively.



USER NAME =	DESIGNED - K.M. GABLE	REVISED	---
	CHECKED - L.V. BORDEN	REVISED	---
PLOT SCALE =	DRAWN - R.S. JOHNSON	REVISED	---
PLOT DATE =	CHECKED - R.I. PETERS	REVISED	---

STATE OF ILLINOIS  
DEPARTMENT OF TRANSPORTATION

VARIOUS MOVABLE BRIDGES  
LOCAL CENTRALIZED CONTROL AND OPERATION  
MCDONOUGH STREET - CCTV PLAN AND ELEVATION  
SHEET NO. 25 OF 40 SHEETS

McDONOUGH, Drawing 05-025				
F.A.U. RTE.	SECTION	COUNTY	TOTAL SHEETS	SHEET NO.
0313	2011-045-I	WILL	466	310
CONTRACT NO. 60P55				
ILLINOIS FED. AID PROJECT				

Bridge Operator House

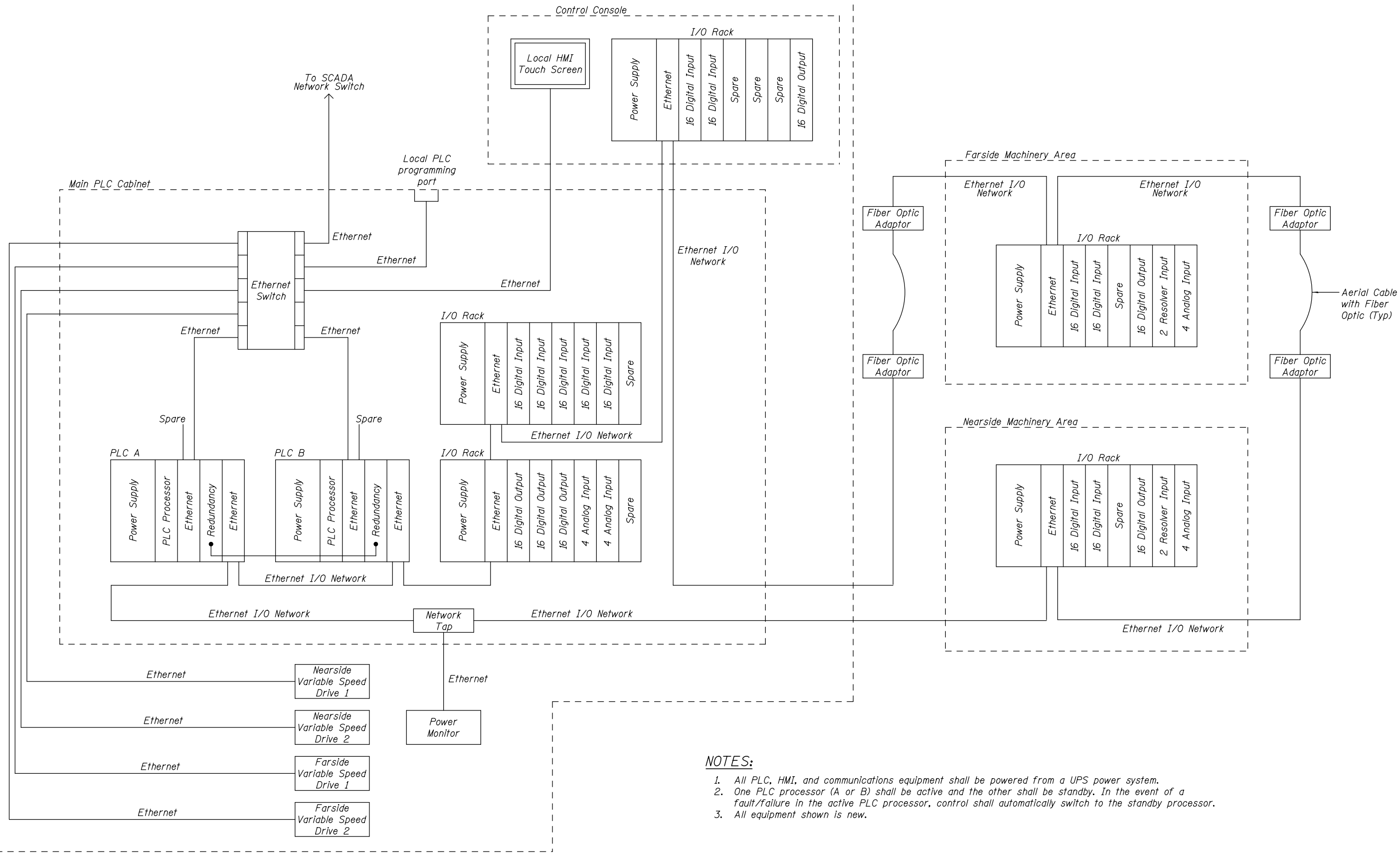

- NOTES:**
1. All PLC, HMI, and communications equipment shall be powered from a UPS power system.
  2. One PLC processor (A or B) shall be active and the other shall be standby. In the event of a fault/failure in the active PLC processor, control shall automatically switch to the standby processor.
  3. All equipment shown is new.



USER NAME =	DESIGNED - R.I. PETERS	REVISED -
	CHECKED - L.V. BORDEN	REVISED -
PLOT SCALE =	DRAWN - R.I. PETERS	REVISED -
PLOT DATE =	CHECKED - K.M. GABLE	REVISED -

**STATE OF ILLINOIS  
DEPARTMENT OF TRANSPORTATION**

**VARIOUS MOVABLE BRIDGES  
LOCAL CENTRALIZED CONTROL AND OPERATION  
MCDONOUGH STREET - BRIDGE CONTROL DIAGRAM**

McDONOUGH, Drawing 05-026				
F.A.U. RTE.	SECTION	COUNTY	TOTAL SHEETS	SHEET NO.
0313	2011-045-I	WILL	466	311
CONTRACT NO. 60P55				
ILLINOIS FED. AID PROJECT				

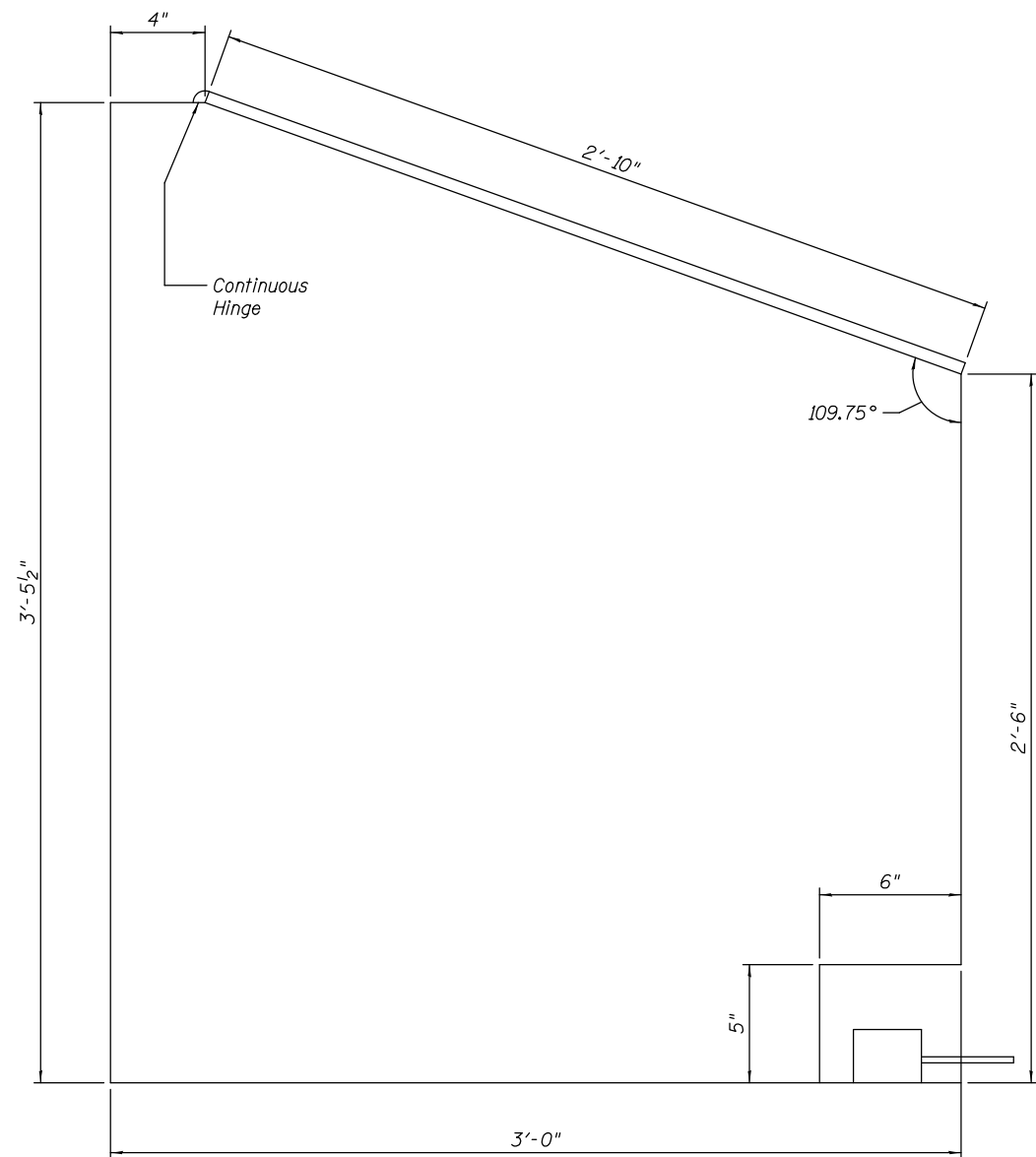

SIDE VIEW

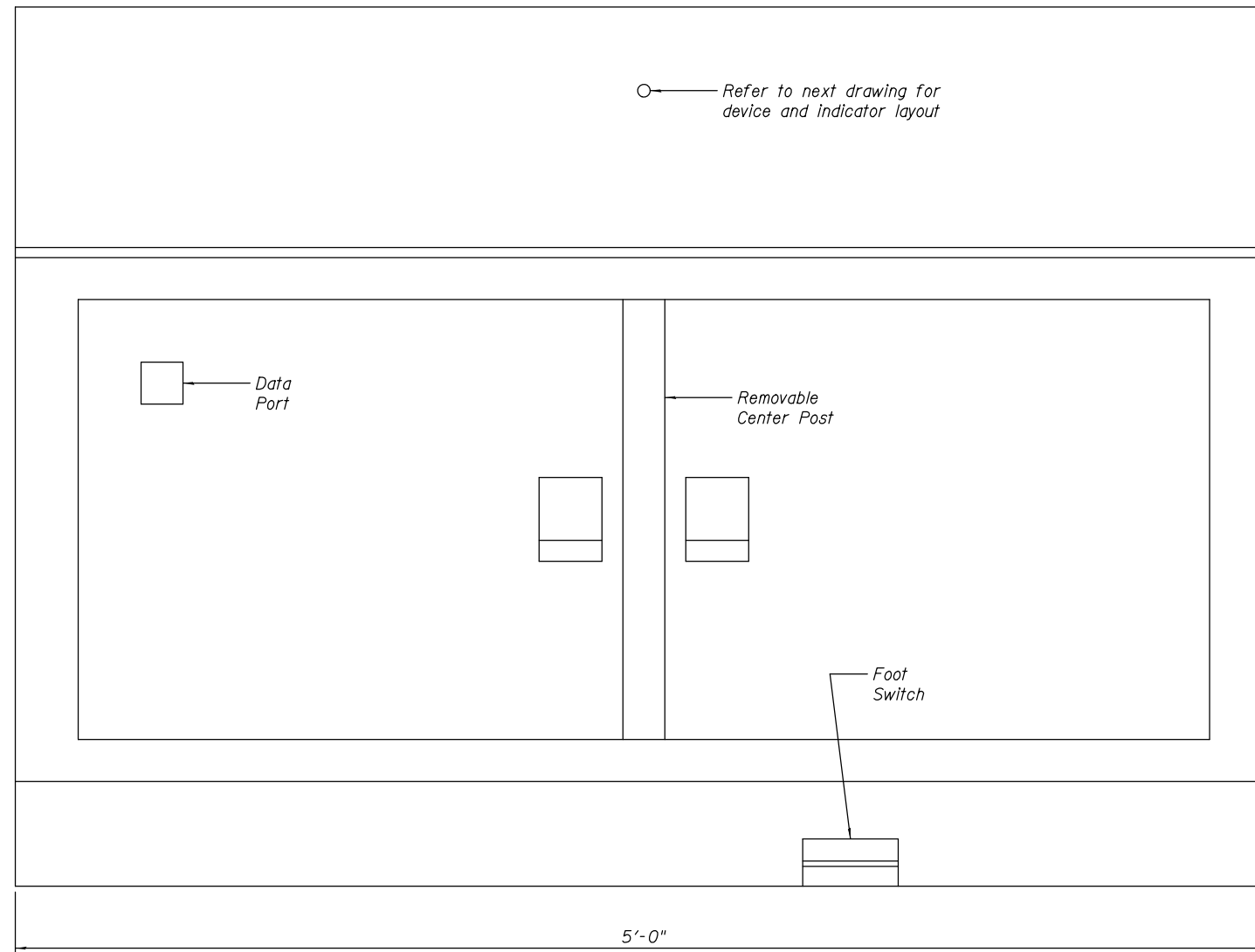

FRONT VIEW

**NOTES:**

1. All dimensions shown are approximate. The Contractor shall submit control console layout and design drawings to the Engineer for approval. Actual control console size shall be based on available operator house space, cabinet components required, and fabrication requirements.
2. Provide additional free standing tables for CCTV controller keyboard/joystick, marine radio, and general utility use. Tables shall be sized and shaped to be placed at either side of the new control console as required by individual control house dimensions. Table tops shall be composite wood or laminated construction, 1" minimum thickness with oil and moisture resistant finish. Legs, top support, cross members, and bracing shall be constructed of powder coated formed steel, minimum 16 gauge. Leg design shall allow height adjustment in 1" increments between approximately 29" to 33".



USER NAME =	DESIGNED - R.I. PETERS	REVISED	---
	CHECKED - L.V. BORDEN	REVISED	---
PLOT SCALE =	DRAWN - R.L. REED	REVISED	---
PLOT DATE =	CHECKED - R.I. PETERS	REVISED	---

**STATE OF ILLINOIS  
DEPARTMENT OF TRANSPORTATION**

**VARIOUS MOVABLE BRIDGES  
LOCAL CENTRALIZED CONTROL AND OPERATION  
MCDONOUGH STREET - NEW BRIDGE CONTROL CONSOLE - 1**  
SHEET NO. 27 OF 40 SHEETS

McDONOUGH, Drawing 05-027		F.A.U. RTE.	SECTION	COUNTY	TOTAL SHEETS	SHEET NO.
0313	2011-045-I	WILL	466	312	CONTRACT NO. 60P55	
ILLINOIS FED. AID PROJECT						

5'-0"

2'-10"

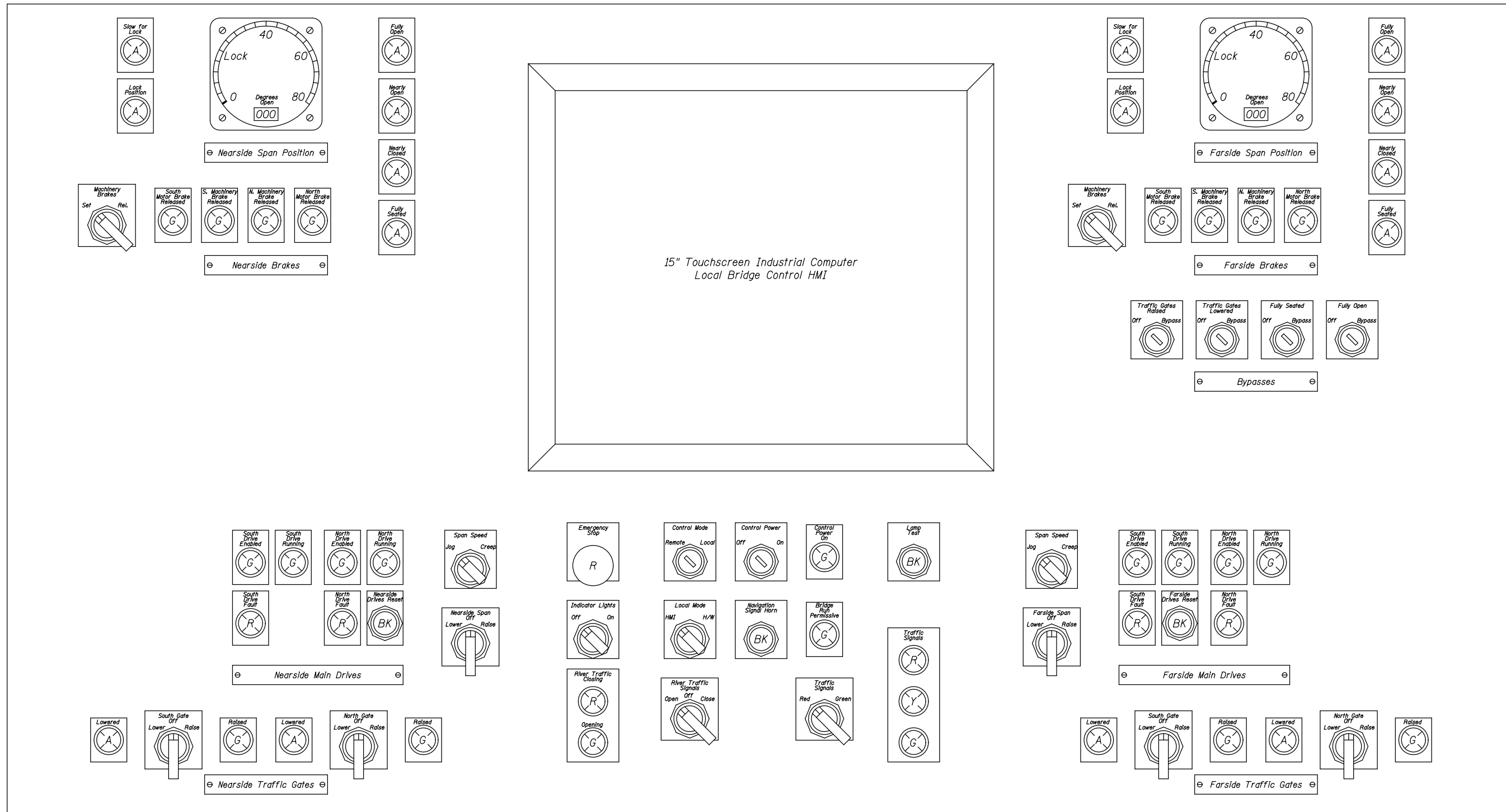

CONTROL CONSOLE DEVICE AND INDICATOR LAYOUT



USER NAME =	DESIGNED - R.I. PETERS	REVISED -
	CHECKED - L.V. BORDEN	REVISED -
PLOT SCALE =	DRAWN - R.L. REED	REVISED -
PLOT DATE =	CHECKED - R.I. PETERS	REVISED -

STATE OF ILLINOIS  
DEPARTMENT OF TRANSPORTATION

VARIOUS MOVABLE BRIDGES  
LOCAL CENTRALIZED CONTROL AND OPERATION  
MCDONOUGH STREET - NEW BRIDGE CONTROL CONSOLE - 2  
SHEET NO. 28 OF 40 SHEETS

McDONOUGH, Drawing 05-028			
F.A.U. RTE.	SECTION	COUNTY	TOTAL SHEETS
0313	2011-045-I	WILL	466
			SHEET NO. 313
CONTRACT NO. 60P55			
ILLINOIS FED. AID PROJECT			

*GROUP 100 EQUIPMENT*

<i>Item No.</i>	<i>Quantity</i>	<i>Item Name</i>	<i>Description</i>
E101	1	Surge Protective Device (SPD)	Bridge electrical service SPD
E102	1	Power Monitor	Bridge electrical service power and energy meter
E103	1	Bus Monitor	Bridge electrical service ABC phase sequencing monitor
E104	N/A		
E105	4	100A Motor Disconnect Switch	Main drive motors
E106	8	30A Motor Disconnect Switch	Brake motors
E107	N/A		
E108	N/A		
E109	2	120/240V Panelboard, 12 Circuit	Replacement panelboard with breakers and accessories

*GROUP 200 EQUIPMENT*

<i>Item No.</i>	<i>Quantity</i>	<i>Item Name</i>	<i>Description</i>
E201	4	Traffic Gate Warning Gong	For existing traffic gates
E202	2	Machinery Warning Horn/Light	Machinery area startup warning
E203	2	Outdoor Warning Horn	Operator house exterior warning
E204	N/A		
E205	2	Boat Detection Sensor	Microwave transmitter and receiver sensor
E206	2	Rotary Cam Limit Switch/Resolver	Bridge position sensing
E207	4	Inclinometer	Bridge open angle sensing
E208	18	Magnetic Proximity Switch	Span fully seated and brake position sensing
E209	N/A		
E210	6	Door Switch	Two piece magnetic contact switch for entry doors
E211	1	Fire Alarm & Security System	Monitor operator house for fire and intrusion

**NOTES:**

1. These equipment schedules are provided for reference and do not provide an exhaustive listing of all equipment required.
2. The Contractor shall be responsible for developing a complete bill of materials of equipment required.



USER NAME =	DESIGNED - R.I. PETERS	REVISED _____
	CHECKED - L.V. BORDEN	REVISED _____
PLOT SCALE =	DRAWN - R.I. PETERS	REVISED _____
PLOT DATE =	CHECKED - K.M. GABLE	REVISED _____

**STATE OF ILLINOIS  
DEPARTMENT OF TRANSPORTATION**

**VARIOUS MOVABLE BRIDGES  
LOCAL CENTRALIZED CONTROL AND OPERATION  
MCDONOUGH STREET – ELECTRICAL EQUIPMENT SCHEDULE**

SHEET NO. 29 OF 40 SHEETS

F.A.U. RTE.	SECTION	COUNTY	TOTAL SHEETS	SHEET NO.
0313	2011-045-I	WILL	466	314
			CONTRACT NO. 60P55	
ILLINOIS FED. AID PROJECT				

McDONOUGH, Drawing 05-029

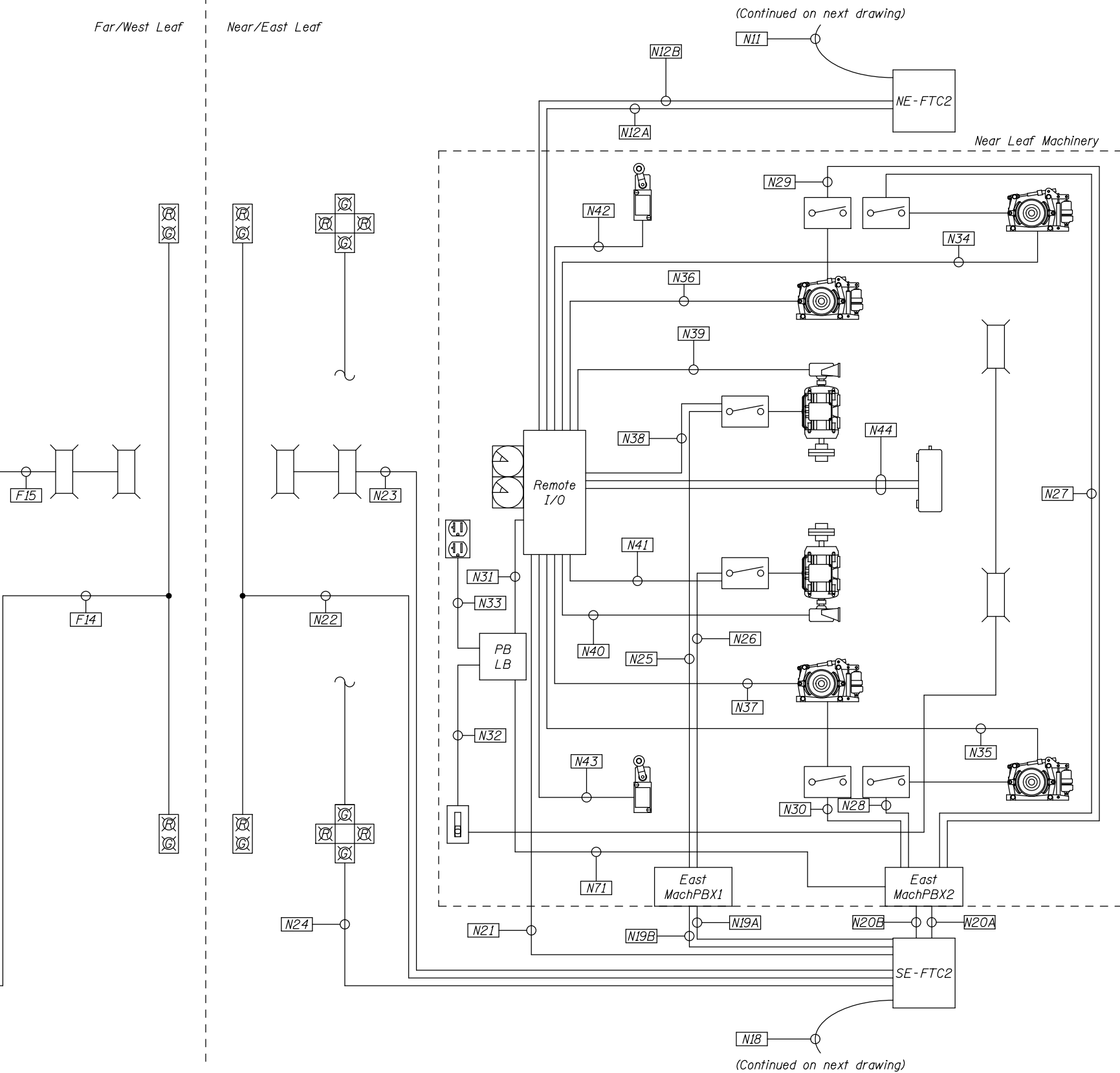
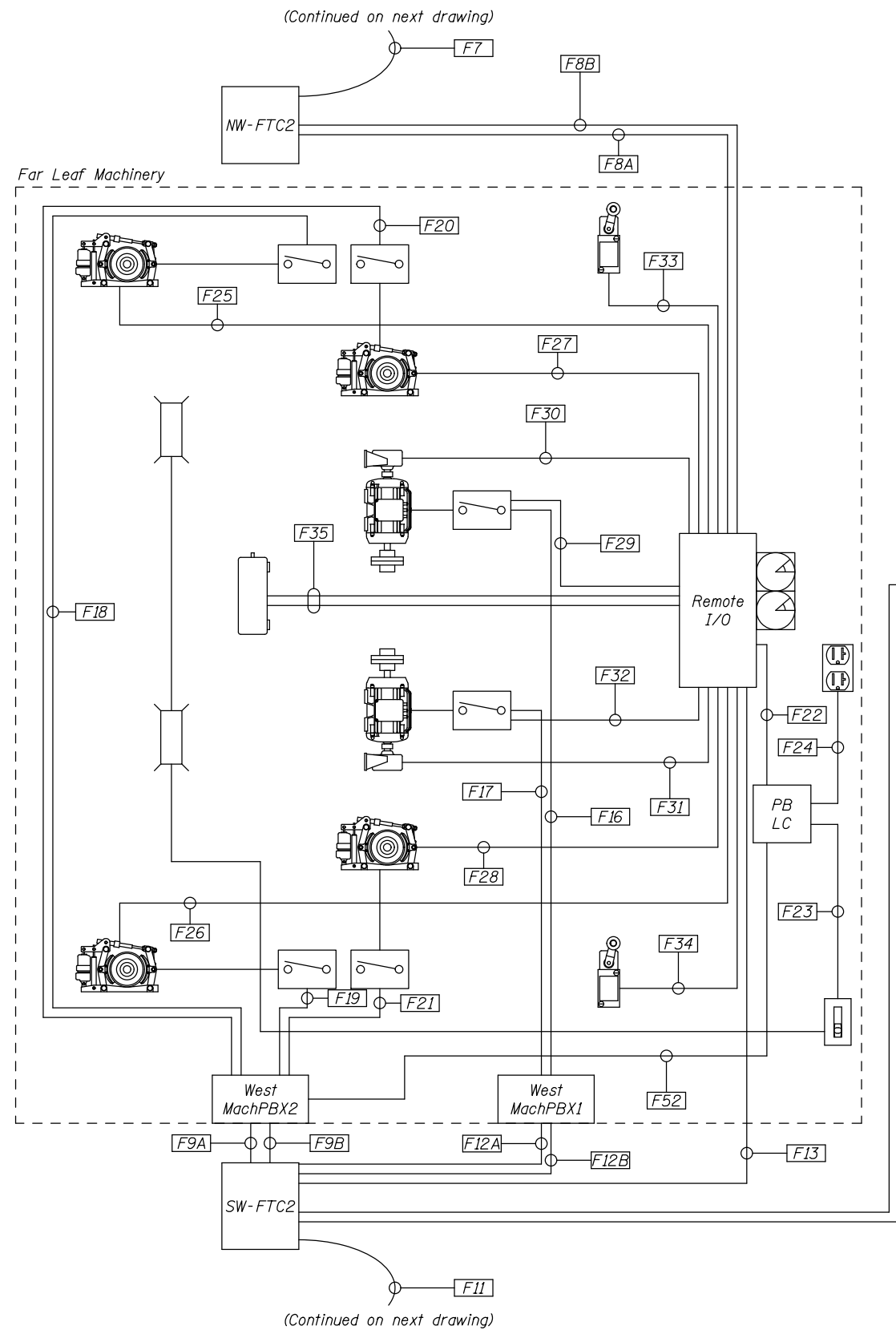

**NOTES:**

1. This layout and the accompanying tabulations are for reference only. All required raceways and wiring are not necessarily shown on this layout.
2. The Contractor shall be responsible for developing a complete wiring and conduit tabulations for all conductors and cables.



USER NAME =	DESIGNED - R.I. PETERS	REVISED -
	CHECKED - L.V. BORDEN	REVISED -
PLOT SCALE =	DRAWN - R.I. PETERS	REVISED -
PLOT DATE =	CHECKED - K.M. GABLE	REVISED -

**STATE OF ILLINOIS  
DEPARTMENT OF TRANSPORTATION**

**VARIOUS MOVABLE BRIDGES  
LOCAL CENTRALIZED CONTROL AND OPERATION  
MCDONOUGH STREET - CONDUIT DIAGRAM - 1**

SHEET NO. 30 OF 40 SHEETS

McDONOUGH, Drawing 05-030				
F.A.U. RTE.	SECTION	COUNTY	TOTAL SHEETS	SHEET NO.
0313	2011-045-1	WILL	466	315
CONTRACT NO. 60P55				
ILLINOIS FED. AID PROJECT				

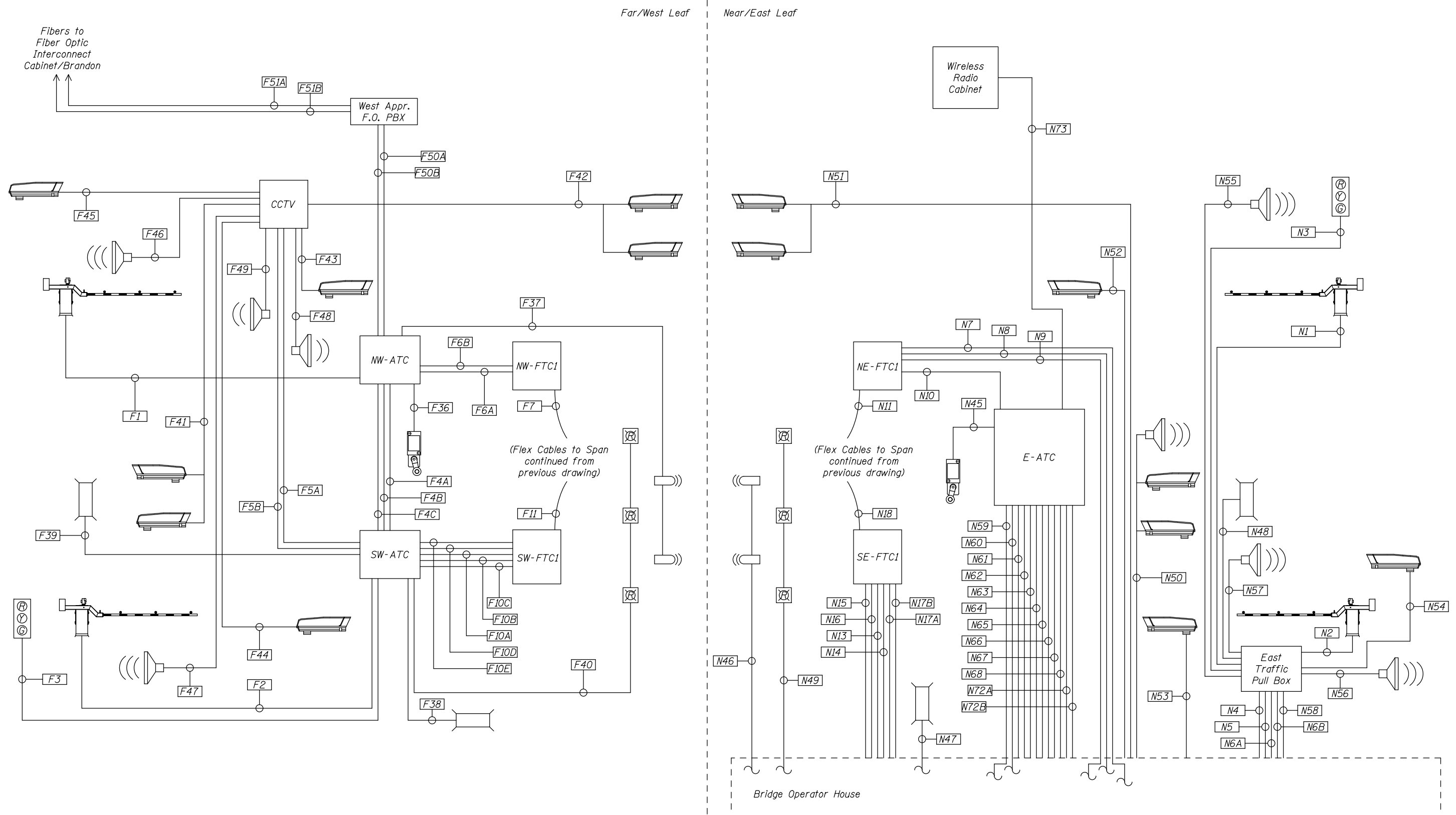

**NOTES:**

1. This layout and the accompanying tabulations are for reference only. All required raceways and wiring are not necessarily shown on this layout.
2. The Contractor shall be responsible for developing a complete wiring and conduit tabulations for all conductors and cables.



USER NAME =	DESIGNED - R.I. PETERS	REVISED -
	CHECKED - L.V. BORDEN	REVISED -
PLOT SCALE =	DRAWN - R.I. PETERS	REVISED -
PLOT DATE =	CHECKED - K.M. GABLE	REVISED -

**STATE OF ILLINOIS  
DEPARTMENT OF TRANSPORTATION**

**VARIOUS MOVABLE BRIDGES  
LOCAL CENTRALIZED CONTROL AND OPERATION  
MCDONOUGH STREET - CONDUIT DIAGRAM - 2**

SHEET NO. 31 OF 40 SHEETS

McDONOUGH, Drawing 05-031				
F.A.U. RTE.	SECTION	COUNTY	TOTAL SHEETS	SHEET NO.
0313	2011-045-1	WILL	466	316
CONTRACT NO. 60P55				
ILLINOIS FED. AID PROJECT				



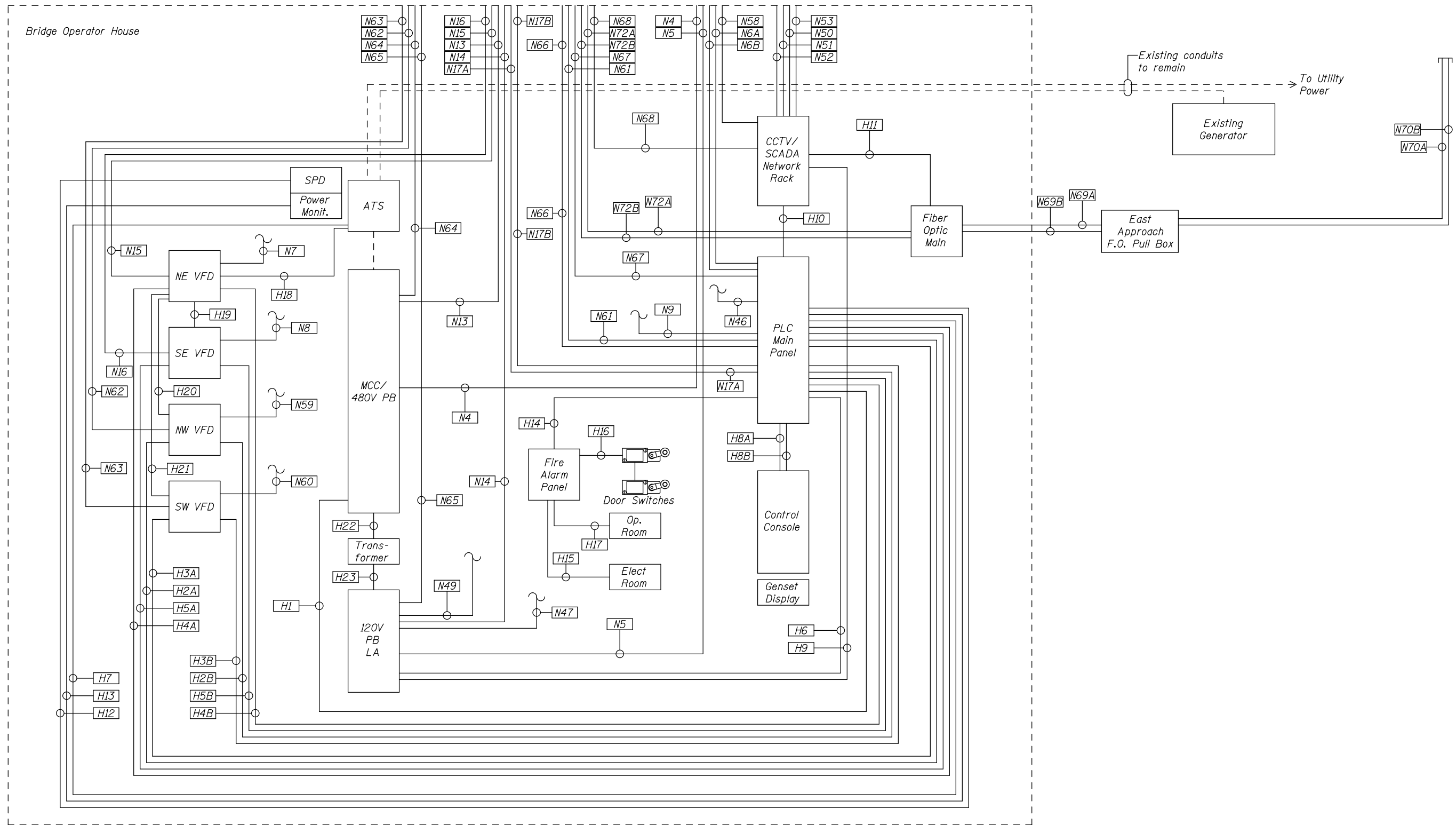

**NOTES:**

1. This layout and the accompanying tabulations are for reference only. All required raceways and wiring are not necessarily shown on this layout.
2. The Contractor shall be responsible for developing a complete wiring and conduit tabulations for all conductors and cables.



USER NAME =	DESIGNED - R.I. PETERS	REVISED -
	CHECKED - L.V. BORDEN	REVISED -
PLOT SCALE =	DRAWN - R.I. PETERS	REVISED -
PLOT DATE =	CHECKED - K.M. GABLE	REVISED -

**STATE OF ILLINOIS  
DEPARTMENT OF TRANSPORTATION**

**VARIOUS MOVABLE BRIDGES  
LOCAL CENTRALIZED CONTROL AND OPERATION  
MCDONOUGH STREET - CONDUIT DIAGRAM - 3**

SHEET NO. 32 OF 40 SHEETS

McDONOUGH, Drawing 05-032				
F.A.U. RTE.	SECTION	COUNTY	TOTAL SHEETS	SHEET NO.
0313	2011-045-I	WILL	466	317
CONTRACT NO. 60P55				
ILLINOIS FED. AID PROJECT				

MCDONOUGH STREET FAR SIDE CONDUIT SCHEDULE									
Run No.	Circuit Terminations		Conduit		Length of Run	Wire			
	To	From	Type	Size		Use	Count	Size	
F1	NW Aerial Cables Terminal Cabinet	NW Traffic Gate	PVC RMC	2"	110	480 P	3	10AWG	
						120 P	9	10AWG	
						SP	3	10AWG	
						120 C	5	12AWG	
						SP	4	12AWG	
F2	SW Aerial Cables Terminal Cabinet	SW Traffic Gate	PVC RMC	2"	110	GND	1	10AWG	
						480 P	3	10AWG	
						120 P	9	10AWG	
						SP	3	10AWG	
						120 C	5	12AWG	
F3	SW Aerial Cables Terminal Cabinet	SW Traffic Signal	PVC RMC	1"	110	SP	4	12AWG	
						GND	1	10AWG	
F4A	NW Aerial Cables Terminal Cabinet	SW Aerial Cables Terminal Cabinet	RMC	1 1/2"	30	480 P	3	10AWG	
						120 P	9	10AWG	
						SP	5	10AWG	
F4B	NW Aerial Cables Terminal Cabinet	SW Aerial Cables Terminal Cabinet	RMC	1 1/2"	30	120 C	5	12AWG	
						SP	5	12AWG	
F4C	NW Aerial Cables Terminal Cabinet	SW Aerial Cables Terminal Cabinet	RMC	1 1/2"	30	GND	1	12AWG	
						FO	1	96 Fiber	
F5A	SW Aerial Cables Terminal Cabinet	Farside CCTV/P.A. Cabinet	RMC	1 1/2"	80	FO	1	12 Fiber	
						120P	2	6AWG	
						120P	2	10AWG	
						SP	4	10AWG	
F5B	SW Aerial Cables Terminal Cabinet	Farside CCTV/P.A. Cabinet	RMC	1"	80	GND	1	6AWG	
						FO	2	12 Fiber	
F6A	NW Aerial Cables Terminal Cabinet	NW Flexible Cable Terminal Cabinet 1 (fixed span)	RMC	2 1/2"	60	120 C	29	12AWG	
						SP	11	12AWG	
						Instrum.	9	2-Pair	
						SP	2	2-Pair	
F6B	NW Aerial Cables Terminal Cabinet	NW Flexible Cable Terminal Cabinet 1 (fixed span)	RMC	1"	60	GND	1	6AWG	
						Ethernet	1	CAT-6	
F7	NW Flexible Cable Terminal Cabinet 1 (fixed span)	NW Flexible Cable Terminal Cabinet 2 (movable span)	FLEX	3"	20	120 C	29	12AWG	
						SP	11	12AWG	
						Instrum.	9	2-Pair	
						SP	2	2-Pair	
						GND	1	6AWG	
F8A	NW Flexible Cable Terminal Cabinet 2 (movable span)	West PLC I/O Cabinet	RMC	2 1/2"	40	Ethernet	1	CAT-6	
						120 C	29	12AWG	
						SP	11	12AWG	
						Instrum.	9	2-Pair	
F8B	NW Flexible Cable Terminal Cabinet 2 (movable span)	West PLC I/O Cabinet	RMC	1"	40	SP	2	2-Pair	
						GND	1	6AWG	
F9A	SW Flexible Cable Terminal Cabinet 2 (movable span)	West Machinery Pull Box 2	RMC	1 1/2"	35	Ethernet	1	CAT-6	
						480 P	12	10AWG	
						SP	5	10AWG	
F9B	SW Flexible Cable Terminal Cabinet 2 (movable span)	West Machinery Pull Box 2	RMC	1 1/2"	35	GND	1	2AWG	
						240 P	3	4AWG	
F10A	SW Aerial Cables Terminal Cabinet	SW Flexible Cable Terminal Cabinet 1 (fixed span)	RMC	2 1/2"	60	SP	2	4AWG	
						GND	1	6AWG	
F10B	SW Aerial Cables Terminal Cabinet	SW Flexible Cable Terminal Cabinet 1 (fixed span)	RMC	2 1/2"	60	480 P	12	10AWG	
						SP	5	10AWG	
F10C	SW Aerial Cables Terminal Cabinet	SW Flexible Cable Terminal Cabinet 1 (fixed span)	RMC	1"	60	GND	4	10AWG	
						Ethernet	1	CAT-6	
F10D	SW Aerial Cables Terminal Cabinet	SW Flexible Cable Terminal Cabinet 1 (fixed span)	RMC	1 1/2"	60	480 P	12	10AWG	
						SP	5	10AWG	

MCDONOUGH STREET FAR SIDE CONDUIT SCHEDULE (CONTINUED)									
Run No.	Circuit Terminations		Conduit		Length of Run	Wire			
	To	From	Type	Size		Use	Count	Size	
F10E	SW Aerial Cables Terminal Cabinet	SW Flexible Cable Terminal Cabinet 1 (fixed span)	RMC	1 1/2"	60	240 P	3	4AWG	
						120 P	4	10AWG	
						SP	5	10AWG	
						GND	1	6AWG	
						GND	2	10AWG	
F11	SW Flexible Cable Terminal Cabinet 1 (fixed span)	SW Flexible Cable Terminal Cabinet 2 (movable span)	FLEX	4"	20	480 VFD	2	(3) 2AWG	
						480 P	12	10AWG	
						240 P	3	4AWG	
						120 P	13	10AWG	
						SP	9	10AWG	
						GND	1	2AWG	
F12A	SW Flexible Cable Terminal Cabinet 2 (movable span)	West Machinery Pull Box 1	RMC	2 1/2"	35	Ethernet	1	CAT-6	
						480 VFD	1	(3) 2AWG	
F12B	SW Flexible Cable Terminal Cabinet 2 (movable span)	West Machinery Pull Box 1	RMC	2 1/2"	35	480 VFD	1	(3) 2AWG	
						Ethernet	1	CAT-6	
F13	SW Flexible Cable Terminal Cabinet 2 (movable span)	West PLC I/O Cabinet	RMC	1"	40	Ethernet	1	CAT-6	
						120 P	3	10AWG	
F14	SW Flexible Cable Terminal Cabinet 2 (movable span)	Center Span Navigation Lights	PVC RMC	3/4"	225	GND	1	10AWG	
						120 P	2	10AWG	
F15	SW Flexible Cable Terminal Cabinet 2 (movable span)	Farside Roadway Lights	RMC	3/4"	125	GND	1	10AWG	
						480 VFD	1	(3) 2AWG	
F16	West Machinery Pull Box 1	NW Motor Disconnect	RMC	2 1/2"	20	480 VFD	1	(3) 2AWG	
						480 VFD	1	(3) 2AWG	
F17	West Machinery Pull Box 1	SW Motor Disconnect	RMC	2 1/2"	15	480 P	3	10AWG	
						GND	1	10AWG	
F18	West Machinery Pull Box 2	NW Machinery Brake Disconnect	RMC	3/4"	30	480 P	3	10AWG	
						GND	1	10AWG	
F19	West Machinery Pull Box 2	SW Machinery Brake Disconnect	RMC	3/4"	10	480 P	3	10AWG	
						GND	1	10AWG	
F20	West Machinery Pull Box 2	NW Motor Brake Disconnect	RMC	3/4"	30	480 P	3	10AWG	
						GND	1	10AWG	
F21	West Machinery Pull Box 2	SW Motor Brake Disconnect	RMC	3/4"	10	480 P	3	10AWG	
						GND	1	10AWG	
F22	LC Panelboard	West PLC I/O Cabinet	RMC	3/4"	5	120 P	6	10AWG	
						GND	3	10AWG	
F23	LC Panelboard	Farside Machinery Room Lights	RMC	3/4"	45	120 P	2	10AWG	
						GND	1	10AWG	
F24	LC Panelboard	Farside Machinery Room Receptacle	RMC	3/4"	20	120 P	2	10AWG	
						GND	1	10AWG	
F25	West PLC I/O Cabinet	NW Machinery Brake	RMC	3/4"	15	120 C	4	12AWG	
						GND	1	12AWG	
F26	West PLC I/O Cabinet	SW Machinery Brake	RMC	3/4"	15	120 C	4	12AWG	
						GND	1	12AWG	
F27	West PLC I/O Cabinet	NW Motor Brake	RMC	3/4"	15	120 C	4	12AWG	
						GND	1	12AWG	
F28	West PLC I/O Cabinet	SW Motor Brake	RMC	3/4"	15	120 C	4	12AWG	
						GND	1	12AWG	
F29	West PLC I/O Cabinet	NW Motor & Disconnect	RMC	3/4"	15	120 P	2	12AWG	
						120 C	3	12AWG	
F30	West PLC I/O Cabinet	NW Motor Encoder	RMC	1"	15	GND	1	12AWG	
						Instrum.	4	2-Pair	
F31	West PLC I/O Cabinet	SW Motor Encoder	RMC	1"	15	GND	1	12AWG	
						Instrum.	4	2-Pair	
F32	West PLC I/O Cabinet	SW Motor & Disconnect	RMC	3/4"	15	120 P	2	12AWG	
						120 C	3	12AWG	
						GND	1	12AWG	
F33	West PLC I/O Cabinet	NW Machinery Door Switch	RMC	3/4"	15	120 C	2	12AWG	
						GND	1	12AWG	
F34	West PLC I/O Cabinet	SW Machinery Door Switch	RMC	3/4"	15	120 C	2	12AWG	
						GND	1	12AWG	

- NOTES:**
- Fiber optic conduit bend radius shall be greater than minimum bend radius of fiber optic cable.
  - Conduit F3 typical from NW Aerial Cables Terminal Cabinet to NW Traffic Signal.



USER NAME =	DESIGNED - K.M. GABLE	REVISED -
PLOT SCALE =	CHECKED - L.V. BORDEN	REVISED -
PLOT DATE =	DRAWN - R.L. REED	REVISED -
	CHECKED - R.I. PETERS	REVISED -

STATE OF ILLINOIS  
DEPARTMENT OF TRANSPORTATION

VARIOUS MOVABLE BRIDGES  
LOCAL CENTRALIZED CONTROL AND OPERATION  
MCDONOUGH STREET - CONDUIT TABULATION - 1  
SHEET NO. 33 OF 40 SHEETS

McDONOUGH, Drawing 05-033				
F.A.U. RTE.	SECTION	COUNTY	TOTAL SHEETS	SHEET NO.
0313	2011-045-I	WILL	466	318
CONTRACT NO. 60P55				
ILLINOIS FED. AID PROJECT				

MCDONOUGH STREET FAR SIDE CONDUIT SCHEDULE (CONTINUED)									
Run No.	Circuit Terminations		Conduit		Length of Run	Wire			
	To	From	Type	Size		Use	Count	Size	
F35	West PLC I/O Cabinet	SW Rotary Cam Limit Switch	RMC	1 1/2"	15	120 C	9	12AWG	
						Instrum.	1	6-Pair	
						GND	1	12AWG	
F36	NW Aerial Cables Terminal Cabinet	West Fully Seated Limit Switch	RMC	3/4"	30	120 C	2	12AWG	
						GND	1	12AWG	
F37	NW Aerial Cables Terminal Cabinet	Farside Boat Defection	PVC RMC	3/4"	135	12VDC	2	12AWG	
						GND	1	12AWG	
F38	SW Aerial Cables Terminal Cabinet	West Fixed Structure Lights	RMC	3/4"	75	120 P	2	10AWG	
						GND	1	10AWG	
F39	SW Aerial Cables Terminal Cabinet	West Approach Roadway Lights	RMC	3/4"	40	120 P	2	10AWG	
						GND	1	10AWG	
F40	SW Aerial Cables Terminal Cabinet	West Pier Navigation Lights	PVC RMC	3/4"	195	120 P	2	10AWG	
						GND	1	10AWG	
F41	Farside CCTV/P.A. Cabinet	West Traffic Cameras	PVC RMC	1"	60	Power	4	12AWG	
						Ethernet	2	CAT-6	
						GND	2	12AWG	
F42	Farside CCTV/P.A. Cabinet	West Thermal and Lower PTZ Cameras	PVC RMC	1"	100	Power	4	12AWG	
						Ethernet	2	CAT-6	
						GND	2	12AWG	
F43	Farside CCTV/P.A. Cabinet	NW Pedestrian Camera	RMC	3/4"	40	Power	2	12AWG	
						Ethernet	1	CAT-6	
						GND	1	12AWG	
F44	Farside CCTV/P.A. Cabinet	SW Pedestrian Camera	RMC	3/4"	110	Power	2	12AWG	
						Ethernet	1	CAT-6	
						GND	1	12AWG	
F45***	Farside CCTV/P.A. Cabinet	West Upper PTZ Camera 2	PVC RMC	3/4"	190	Power	2	12AWG	
						Ethernet	1	CAT-6	
						GND	1	12AWG	
F46	Farside CCTV/P.A. Cabinet	NW Gate P.A. Speaker	PVC RMC	3/4"	100	Speaker	2	AUDIO	
						N/A	0	CAT-6	
						GND	1	12AWG	
F47	Farside CCTV/P.A. Cabinet	SW Gate P.A. Speaker	PVC RMC	3/4"	150	Speaker	2	AUDIO	
						N/A	0	CAT-6	
						GND	1	12AWG	
F48	Farside CCTV/P.A. Cabinet	NW Approach P.A. Speaker	PVC RMC	3/4"	200	Speaker	2	AUDIO	
						N/A	0	CAT-6	
						GND	1	12AWG	
F49	Farside CCTV/P.A. Cabinet	West One-Way P.A. Speakers	RMC	3/4"	150	Speaker	2	AUDIO	
						N/A	0	CAT-6	
						GND	1	12AWG	
F50A**	NW Aerial Cables Terminal Cabinet	West Approach Fiber Optic Pull Box	PVC RMC	2"	145	FO	1	96 Fiber	
F50B**	NW Aerial Cables Terminal Cabinet	West Approach Fiber Optic Pull Box	PVC RMC	2"	145	FO	1	96 Fiber	
F51A**	West Approach Fiber Optic Pull Box	West (Outdoor) Fiber Optic Interconnect. Cabinet	PVC RMC	2"	75	FO	1	96 Fiber	
F51B**	West Approach Fiber Optic Pull Box	West (Outdoor) Fiber Optic Interconnect. Cabinet	PVC RMC	2"	75	FO	1	96 Fiber	
F52	West Machinery Pull Box 2	LC Panelboard	RMC	1"	20	240 P	3	4AWG	
						GND	1	6AWG	

MCDONOUGH STREET NEAR SIDE CONDUIT SCHEDULE									
Run No.	Circuit Terminations		Conduit		Length of Run	Wire			
	To	From	Type	Size		Use	Count	Size	
N1	East Approach Traffic Pull Box	NE Traffic Gate	PVC RMC	2"	85	480 P	3	10AWG	
						120 P	9	10AWG	
						SP	3	10AWG	
						120 C	5	12AWG	
						SP	4	12AWG	
GND	1	10AWG							

MCDONOUGH STREET NEAR SIDE CONDUIT SCHEDULE (CONTINUED)									
Run No.	Circuit Terminations		Conduit		Length of Run	Wire			
	To	From	Type	Size		Use	Count	Size	
N2	East Approach Traffic Pull Box	SE Traffic Gate	PVC RMC	2"	30	480 P	3	10AWG	
						120 P	9	10AWG	
						SP	3	10AWG	
						120 C	5	12AWG	
						SP	4	12AWG	
N3	East Approach Traffic Pull Box	NE Traffic Signal	PVC RMC	1"	85	GND	1	10AWG	
						120 P	4	10AWG	
N4	East Approach Traffic Pull Box	MCC	RMC	1 1/2"	50	480 P	6	10AWG	
						SP	5	10AWG	
						GND	2	10AWG	
N5	East Approach Traffic Pull Box	LA Panelboard	RMC	1 1/2"	50	480 P	10	10AWG	
						SP	2	10AWG	
						GND	5	10AWG	
N6A	East Approach Traffic Pull Box	PLC Main Panel	RMC	1 1/2"	50	120 P	10	10AWG	
						SP	5	10AWG	
						GND	1	10AWG	
N6B	East Approach Traffic Pull Box	PLC Main Panel	RMC	1"	50	120 C	15	12AWG	
						120 C	3	12AWG	
						SP	3	12AWG	
N7	NE Flexible Cable Terminal Cabinet 1 (fixed span)	NE VFD Cabinet	RMC	1 1/2"	115	Instrum.	4	2-Pair	
						SP	2	2-Pair	
						GND	1	6AWG	
						120 C	3	12AWG	
N8	NE Flexible Cable Terminal Cabinet 1 (fixed span)	SE VFD Cabinet	RMC	1 1/2"	115	SP	3	12AWG	
						Instrum.	4	2-Pair	
						SP	2	2-Pair	
						GND	1	6AWG	
N9	NE Flexible Cable Terminal Cabinet 1 (fixed span)	PLC Main Panel	RMC	2"	115	120 C	23	12AWG	
						SP	11	12AWG	
						Instrum.	1	2-Pair	
						SP	2	2-Pair	
N10	NE Flexible Cable Terminal Cabinet 1 (fixed span)	East Aerial Cables Terminal Cabinet	RMC	1"	60	Ethernet	1	CAT-6	
						120 C	29	12AWG	
N11	NE Flexible Cable Terminal Cabinet 1 (fixed span)	NE Flexible Cable Terminal Cabinet 2 (movable span)	FLEX	3"	20	SP	11	12AWG	
						Instrum.	9	2-Pair	
						SP	2	2-Pair	
						GND	1	6AWG	
						Ethernet	1	CAT-6	
N12A	NE Flexible Cable Terminal Cabinet 2 (movable span)	East PLC I/O Cabinet	RMC	2 1/2"	40	120 C	29	12AWG	
						SP	11	12AWG	
						Instrum.	9	2-Pair	
						SP	2	2-Pair	
N12B	NE Flexible Cable Terminal Cabinet 2 (movable span)	East PLC I/O Cabinet	RMC	1"	40	Ethernet	1	CAT-6	
						GND	1	6AWG	
N13*	SE Flexible Cable Terminal Cabinet 1 (fixed span)	MCC	RMC	1 1/2"	55	480 P	12	10AWG	
						SP	5	10AWG	
						GND	1	2AWG	
N14	SE Flexible Cable Terminal Cabinet 1 (fixed span)	LA Panelboard	RMC	2 1/2"	55	240 P	3	6AWG	
						120 P	4	10AWG	
						SP	5	10AWG	
						GND	1	2AWG	
N15*	SE Flexible Cable Terminal Cabinet 1 (fixed span)	NE VFD Cabinet	RMC	2 1/2"	55	480 VFD	1	(3) 2AWG	
						GND	1	2AWG	
N16*	SE Flexible Cable Terminal Cabinet 1 (fixed span)	SE VFD Cabinet	RMC	2 1/2"	55	480 VFD	1	(3) 2AWG	
						GND	1	2AWG	
						120 C	5	12AWG	
N17A*	SE Flexible Cable Terminal Cabinet 1 (fixed span)	PLC Main Panel	RMC	1"	55	Ethernet	1	CAT-6	
						GND	1	10AWG	

- NOTES:**
- \* Existing conduit (or partial section of conduit) shall be permitted to be reused by the Contractor.
  - \*\* Denotes conduit run to contain excess slack of fiber optic cable from aerial cable assembly. Refer to drawing 05-037 for Aerial Cable Details.
  - \*\*\* Use of RMC shall be permitted where conduit is exposed, mounted to bridge structure.
  - Portions of conduits F45, F51A, and F51B shall be direct buried.
  - Portions of conduits N1, N2, and N3 beyond the bridge approach structure will require the existing sidewalk to be sawcut and refinished.
  - Fiber optic conduit bend radius shall be greater than minimum bend radius of fiber optic cable.
  - Conduit N3 typical to SE Traffic Signal.

MCDONOUGH STREET FAR SIDE CONDUIT SCHEDULE (CONTINUED)

Run No.	Circuit Terminations		Conduit		Length of Run	Wire		
	To	From	Type	Size		Use	Count	Size
N17B	SE Flexible Cable Terminal Cabinet 1 (fixed span)	PLC Main Panel	RMC	3/4"	55	120 P	3	10AWG
						GND	1	10AWG
N18	SE Flexible Cable Terminal Cabinet 1 (fixed span)	SE Flexible Cable Terminal Cabinet 2 (movable span)	FLEX	4"	20	480 VFD	2	(3) 2AWG
						480 P	4	10AWG
						240 P	4	6AWG
						120 P	20	10AWG
						SP	9	10AWG
						GND	1	2AWG
						Ethernet	1	CAT-6
N19A*	SE Flexible Cable Terminal Cabinet 2 (movable span)	East Machinery Pull Box 1	RMC	2 1/2"	35	480 VFD	1	(3) 2AWG
N19B*	SE Flexible Cable Terminal Cabinet 2 (movable span)	East Machinery Pull Box 1	RMC	2 1/2"	35	480 VFD	1	(3) 2AWG
N20A	SE Flexible Cable Terminal Cabinet 2 (movable span)	East Machinery Pull Box 2	RMC	1 1/2"	35	480 P	12	10AWG
						SP	5	10AWG
						GND	4	10AWG
N20B	SE Flexible Cable Terminal Cabinet 2 (movable span)	East Machinery Pull Box 2	RMC	1 1/2"	35	240 P	3	6AWG
						120 P	4	10AWG
						SP	5	10AWG
						GND	1	8AWG
						GND	5	10AWG
N20B	SE Flexible Cable Terminal Cabinet 2 (movable span)	East Machinery Pull Box 2	RMC	1 1/2"	35	120 P	10	10AWG
						SP	5	10AWG
						GND	5	10AWG
N21	SE Flexible Cable Terminal Cabinet 2 (movable span)	East PLC I/O Cabinet	RMC	1"	40	Ethernet	1	CAT-6
N22	SE Flexible Cable Terminal Cabinet 2 (movable span)	Center Span Navigation Lights	PVC RMC	3/4"	225	120 P	3	10AWG
						GND	1	10AWG
N23	SE Flexible Cable Terminal Cabinet 2 (movable span)	Nearside Roadway Lights	RMC	3/4"	190	120 P	2	10AWG
						GND	1	10AWG
N24	SE Flexible Cable Terminal Cabinet 2 (movable span)	River Signals	RMC	3/4"	125	120 P	5	10AWG
						GND	1	10AWG
N25	East Machinery Pull Box 1	NE Motor Disconnect	RMC	2 1/2"	20	480 VFD	1	(3) 2AWG
N26	East Machinery Pull Box 1	SE Motor Disconnect	RMC	2 1/2"	15	480 VFD	1	(3) 2AWG
N27	East Machinery Pull Box 2	NE Machinery Brake Disconnect	RMC	3/4"	30	480 P	3	10AWG
						GND	1	10AWG
N28	East Machinery Pull Box 2	SE Machinery Brake Disconnect	RMC	3/4"	10	480 P	3	10AWG
						GND	1	10AWG
N29*	East Machinery Pull Box 2	NE Motor Brake Disconnect	RMC	3/4"	30	480 P	3	10AWG
						GND	1	10AWG
N30*	East Machinery Pull Box 2	SE Motor Brake Disconnect	RMC	3/4"	10	480 P	3	10AWG
						GND	1	10AWG
N31	Panelboard LB	East PLC I/O Cabinet	RMC	3/4"	5	120 P	6	10AWG
						GND	3	10AWG
N32*	Panelboard LB	Nearside Machinery Room Lights	RMC	3/4"	45	120 P	2	10AWG
						GND	1	10AWG
N33*	Panelboard LB	Nearside Machinery Room Receptacle	RMC	3/4"	20	120 P	2	10AWG
						GND	1	10AWG
N34	East PLC I/O Cabinet	NE Machinery Brake	RMC	3/4"	15	120 C	4	12AWG
						GND	1	12AWG
N35	East PLC I/O Cabinet	SE Machinery Brake	RMC	3/4"	15	120 C	4	12AWG
						GND	1	12AWG
N36	East PLC I/O Cabinet	NE Motor Brake	RMC	3/4"	15	120 C	4	12AWG
						GND	1	12AWG
N37	East PLC I/O Cabinet	SE Motor Brake	RMC	3/4"	15	120 C	4	12AWG
						GND	1	12AWG
N38	East PLC I/O Cabinet	NE Motor & Disconnect	RMC	3/4"	15	120 P	2	12AWG
						120 C	3	12AWG
						GND	1	12AWG

MCDONOUGH STREET NEAR SIDE CONDUIT SCHEDULE (CONTINUED)

Run No.	Circuit Terminations		Conduit		Length of Run	Wire		
	To	From	Type	Size		Use	Count	Size
N39	East PLC I/O Cabinet	NE Motor Encoder	RMC	1"	15	Instrum.	4	2-Pair
						GND	1	12AWG
N40	East PLC I/O Cabinet	SE Motor Encoder	RMC	1"	15	Instrum.	4	2-Pair
						GND	1	12AWG
N41	East PLC I/O Cabinet	SE Motor & Disconnect	RMC	3/4"	15	120 P	2	12AWG
						120 C	3	12AWG
						GND	1	12AWG
N42	East PLC I/O Cabinet	NE Machinery Door Switch	RMC	3/4"	15	120 C	2	12AWG
						GND	1	12AWG
N43	East PLC I/O Cabinet	SE Machinery Door Switch	RMC	3/4"	15	120 C	2	12AWG
						GND	1	12AWG
N44	East PLC I/O Cabinet	SE Rotary Cam Limit Switch	RMC	1 1/2"	15	120 C	9	12AWG
						Instrum.	1	6-Pair
						GND	1	12AWG
N45	East Aerial Cables Terminal Cabinet	East Fully Seated Limit Switch	RMC	3/4"	30	120 C	2	12AWG
						GND	1	12AWG
N46	PLC Main Panel	Nearside Boat Detection	PVC RMC	3/4"	90	12VDC	6	12AWG
						GND	1	12AWG
N47	LA Panelboard	East Fixed Structure Lights	RMC	3/4"	65	120 P	2	10AWG
						GND	1	10AWG
N48	East Approach Traffic Pull Box	East Approach Roadway Lights	RMC	3/4"	40	120 P	2	10AWG
						GND	1	10AWG
N49	LA Panelboard	East Pier Navigation Lights	PVC RMC	3/4"	95	120 P	2	10AWG
						GND	1	10AWG
N50	CCTV/SCADA Network Rack	East Traffic Cameras & One-way P.A. Speakers	RMC	1 1/2"	120	Power	4	12AWG
						Ethernet	2	CAT-6
						Speaker	2	AUDIO
						GND	4	12AWG
N51	CCTV/SCADA Network Rack	East Thermal & Lower PTZ Cameras	PVC RMC	1"	100	Power	4	12AWG
						Ethernet	2	CAT-6
						GND	2	12AWG
N52	CCTV/SCADA Network Rack	NE Pedestrian Camera	RMC	3/4"	110	Power	2	12AWG
						Ethernet	1	CAT-6
						GND	1	12AWG
N53	CCTV/SCADA Network Rack	SE Pedestrian Camera	RMC	3/4"	40	Power	2	12AWG
						Ethernet	1	CAT-6
						GND	1	12AWG
N54	East Approach Traffic Pull Box	East Upper PTZ Camera 1	PVC RMC	3/4"	100	Power	2	12AWG
						Ethernet	1	CAT-6
						GND	1	12AWG
N55	East Approach Traffic Pull Box	NE Gate P.A. Speaker	PVC RMC	3/4"	65	Speaker	2	AUDIO
						N/A	0	CAT-6
						GND	1	12AWG
N56	East Approach Traffic Pull Box	SE Gate P.A. Speaker	PVC RMC	3/4"	15	Speaker	2	AUDIO
						N/A	0	CAT-6
						GND	1	12AWG
N57	East Approach Traffic Pull Box	SE Approach P.A. Speaker	PVC RMC	3/4"	100	Speaker	2	AUDIO
						N/A	0	CAT-6
						GND	1	12AWG
N58	CCTV/SCADA Network Rack	East Approach Traffic Pull Box	RMC	1 1/2"	40	Power	2	12AWG
						Ethernet	1	CAT-6
						Speaker	6	AUDIO
						GND	4	12AWG
N59	East Aerial Cables Terminal Cabinet	NW VFD Cabinet	RMC	1 1/2"	150	120 C	3	12AWG
						SP	3	12AWG
						Instrum.	4	2-Pair
						SP	2	2-Pair
						GND	1	6AWG
N60	East Aerial Cables Terminal Cabinet	SW VFD Cabinet	RMC	1 1/2"	150	120 C	3	12AWG
						SP	3	12AWG
						Instrum.	4	2-Pair
						SP	2	2-Pair
						GND	1	6AWG

NOTES:

- \* Existing conduit (or partial section of conduit) shall be permitted to be reused by the Contractor.
- Portion of conduit N54 shall be direct buried.



USER NAME =	DESIGNED - K.M. GABLE	REVISED -
	CHECKED - L.V. BORDEN	REVISED -
PLOT SCALE =	DRAWN - R.L. REED	REVISED -
PLOT DATE =	CHECKED - R.I. PETERS	REVISED -

STATE OF ILLINOIS  
DEPARTMENT OF TRANSPORTATION

VARIOUS MOVABLE BRIDGES  
LOCAL CENTRALIZED CONTROL AND OPERATION  
MCDONOUGH STREET - CONDUIT TABULATION - 3  
SHEET NO. 35 OF 40 SHEETS

McDONOUGH, Drawing 05-035			
F.A.U. RTE.	SECTION	COUNTY	TOTAL SHEETS
0313	2011-045-I	WILL	466
			SHEET NO. 320
CONTRACT NO. 60P55			
ILLINOIS FED. AID PROJECT			

MCDONOUGH STREET NEARSIDE CONDUIT SCHEDULE (CONTINUED)									
Run No.	Circuit Terminations		Conduit		Length of Run	Wire			
	To	From	Type	Size		Use	Count	Size	
N61	East Aerial Cables Terminal Cabinet	PLC Main Panel	RMC	2 1/2"	150	120 C	23	12AWG	
						120 C	14	12AWG	
						SP	10	12AWG	
						Instrum.	1	2-Pair	
						SP	2	2-Pair	
					GND	1	6AWG		
N62*	East Aerial Cables Terminal Cabinet	NW VFD Cabinet	RMC	2 1/2"	150	480 VFD	1	(3) 2AWG	
N63*	East Aerial Cables Terminal Cabinet	SW VFD Cabinet	RMC	2 1/2"	150	480 VFD	1	(3) 2AWG	
N64	East Aerial Cables Terminal Cabinet	MCC	RMC	1 1/2"	150	480 P	18	10AWG	
						SP	5	10AWG	
						GND	1	2AWG	
N65	East Aerial Cables Terminal Cabinet	LA Panelboard	RMC	2"	150	240 P	3	4AWG	
						120 P	2	6AWG	
						120 P	12	10AWG	
						SP	5	10AWG	
						GND	1	2AWG	
N66	East Aerial Cables Terminal Cabinet	PLC Main Panel	RMC	1 1/2"	150	120 P	3	10AWG	
						120 P	14	10AWG	
						SP	5	10AWG	
						GND	1	2AWG	
N67	East Aerial Cables Terminal Cabinet	PLC Main Panel	RMC	1"	150	FO	1	12 Fiber	
N68	East Aerial Cables Terminal Cabinet	CCTV/SCADA Network Rack	RMC	1 1/2"	150	FO	2	12 Fiber	
						Ethernet	2	CAT-6	
N69A	Fiber Optic Interconnect Cabinet	East Approach Fiber Optic Pull Box	PVC RMC	2"	15	Empty (note 4)			
N69B	Fiber Optic Interconnect Cabinet	East Approach Fiber Optic Pull Box	PVC RMC	2"	15	Empty (note 4)			
N70A	East Approach Fiber Optic Pull Box	Cap end of empty conduit	PVC RMC	2"	125	Empty (note 4)			
N70B	East Approach Fiber Optic Pull Box	Cap end of empty conduit	PVC RMC	2"	125	Empty (note 4)			
N71	East Machinery Pull Box 2	Panelboard LB	RMC	1"	20	240 P	3	6AWG	
						GND	1	8AWG	
N72A**	East Aerial Cables Terminal Cabinet	Fiber Optic Interconnect Cabinet	RMC	2"	150	FO	1	96 Fiber	
N72B**	East Aerial Cables Terminal Cabinet	Fiber Optic Interconnect Cabinet	RMC	2"	150	FO	1	96 Fiber	
N73	East Aerial Cables Terminal Cabinet	Wireless Radio Cabinet	RMC	1 1/2"	15	120 P	4	10AWG	
						Ethernet	2	CAT-6	
						GND	2	10AWG	

MCDONOUGH STREET OPERATOR HOUSE CONDUIT SCHEDULE									
Run No.	Circuit Terminations		Conduit		Length of Run	Wire			
	To	From	Type	Size		Use	Count	Size	
H1	MCC	PLC Main Panel	RMC	1 1/2"	15	120 C	16	12AWG	
						SP	5	12AWG	
						GND	1	12AWG	
H2A	NW VFD Cabinet	PLC Main Panel	RMC	1"	16	120 C	14	12AWG	
H2B	NW VFD Cabinet	PLC Main Panel	RMC	1"	16	GND	1	12AWG	
						Instrum.	2	2-PAIR	
H3A	SW VFD Cabinet	PLC Main Panel	RMC	1"	16	Ethernet	1	CAT-6	
						120 C	14	12AWG	
						GND	1	12AWG	

MCDONOUGH STREET OPERATOR HOUSE CONDUIT SCHEDULE (CONTINUED)									
Run No.	Circuit Terminations		Conduit		Length of Run	Wire			
	To	From	Type	Size		Use	Count	Size	
H3B	SW VFD Cabinet	PLC Main Panel	RMC	1"	16	Instrum.	2	2-PAIR	
						Ethernet	1	CAT-6	
H4A	NE VFD Cabinet	PLC Main Panel	RMC	1"	16	120 C	14	12AWG	
						GND	1	12AWG	
H4B	NE VFD Cabinet	PLC Main Panel	RMC	1"	16	Instrum.	2	2-PAIR	
						Ethernet	1	CAT-6	
H5A	SE VFD Cabinet	PLC Main Panel	RMC	1"	16	120 C	14	12AWG	
						GND	1	12AWG	
H5B	SE VFD Cabinet	PLC Main Panel	RMC	1"	16	Instrum.	2	2-PAIR	
						Ethernet	1	CAT-6	
H6	LA Panelboard	PLC Main Panel	RMC	1 1/2"	24	120 P	12	10AWG	
						120 P	6	10AWG	
						SP	2	10AWG	
						GND	9	10AWG	
H7	Auto Transfer Switch	PLC Main Panel	RMC	3/4"	15	120 C	5	12AWG	
						GND	1	12AWG	
H8A	Control Console	PLC Main Panel	RMC	2 1/2"	12	120 P	4	10AWG	
						120 C	60	12AWG	
						Instrum.	0	2-PAIR	
						Ethernet	0	CAT-6	
H8B	Control Console	PLC Main Panel	RMC	2 1/2"	12	GND	1	10AWG	
						120 C	60	12AWG	
						Instrum.	2	2-PAIR	
						Ethernet	3	CAT-6	
H9	LA Panelboard	CCTV/SCADA Network Rack	RMC	3/4"	25	GND	1	10AWG	
						120 P	4	10AWG	
						120 C	3	12AWG	
						Ethernet	2	CAT-6	
H10	CCTV/SCADA Network Rack	PLC Main Panel	RMC	1"	20	FO	2	12 Fiber	
H11	CCTV/SCADA Network Rack	Fiber Optic Interconnect Cabinet	RMC	1"	18	FO	2	12 Fiber	
H12	PLC Main Panel	SPD / BUS Monitor	RMC	3/4"	15	120 C	4	12AWG	
						GND	2	12AWG	
H13	PLC Main Panel	Power Monitor	RMC	1"	15	Ethernet	1	CAT-6	
H14	PLC Main Panel	Fire Alarm and Security System Control Panel	RMC	3/4"	40	120 C	4	12AWG	
						GND	1	12AWG	
H15	Fire Alarm and Security System Control Panel	Electrical Room Detectors	RMC	1"	25	120 C	9	12AWG	
						GND	3	12AWG	
H16	Fire Alarm and Security System Control Panel	Door Switches	RMC	3/4"	25	120 C	6	12AWG	
						GND	2	12AWG	
H17	Fire Alarm and Security System Control Panel	Operator Room Detectors	RMC	3/4"	50	120 C	6	12AWG	
						GND	2	12AWG	
H18	ATS	NE VFD Cabinet	RMC	3"	25	480 P	6	250	
						GND	1	3AWG	
						480 P	3	2/0	
H19	NE VFD Cabinet	SE VFD Cabinet	RMC	1 1/2"	6	GND	1	3AWG	
						480 P	3	2/0	
						GND	1	3AWG	
H20	NE VFD Cabinet	NW VFD Cabinet	RMC	1 1/2"	12	480 P	3	2/0	
						GND	1	3AWG	
						480 P	3	2/0	
H21	NE VFD Cabinet	SW VFD Cabinet	RMC	1 1/2"	18	GND	1	3AWG	
						480 P	2	3/0	
						480 P	3	2/0	
H22	MCC	Transformer	RMC	1 1/2"	20	GND	1	4AWG	
						480 P	3	3/0	
H23	Transformer	LA Panelboard	RMC	2"	15	GND	1	4AWG	

- NOTES:**
- \* Existing conduit (or partial section of conduit) shall be permitted to be reused by the Contractor.
  - \*\* Denotes conduit run to contain excess slack of fiber optic cable from aerial cable assembly. Refer to drawing 05-037 for Aerial Cable Details.
  - Fiber optic conduit bend radius shall be greater than minimum bend radius of fiber optic cable.
  - Provide and install empty conduit for future fiber connection under separate Fiber Optic Contract.

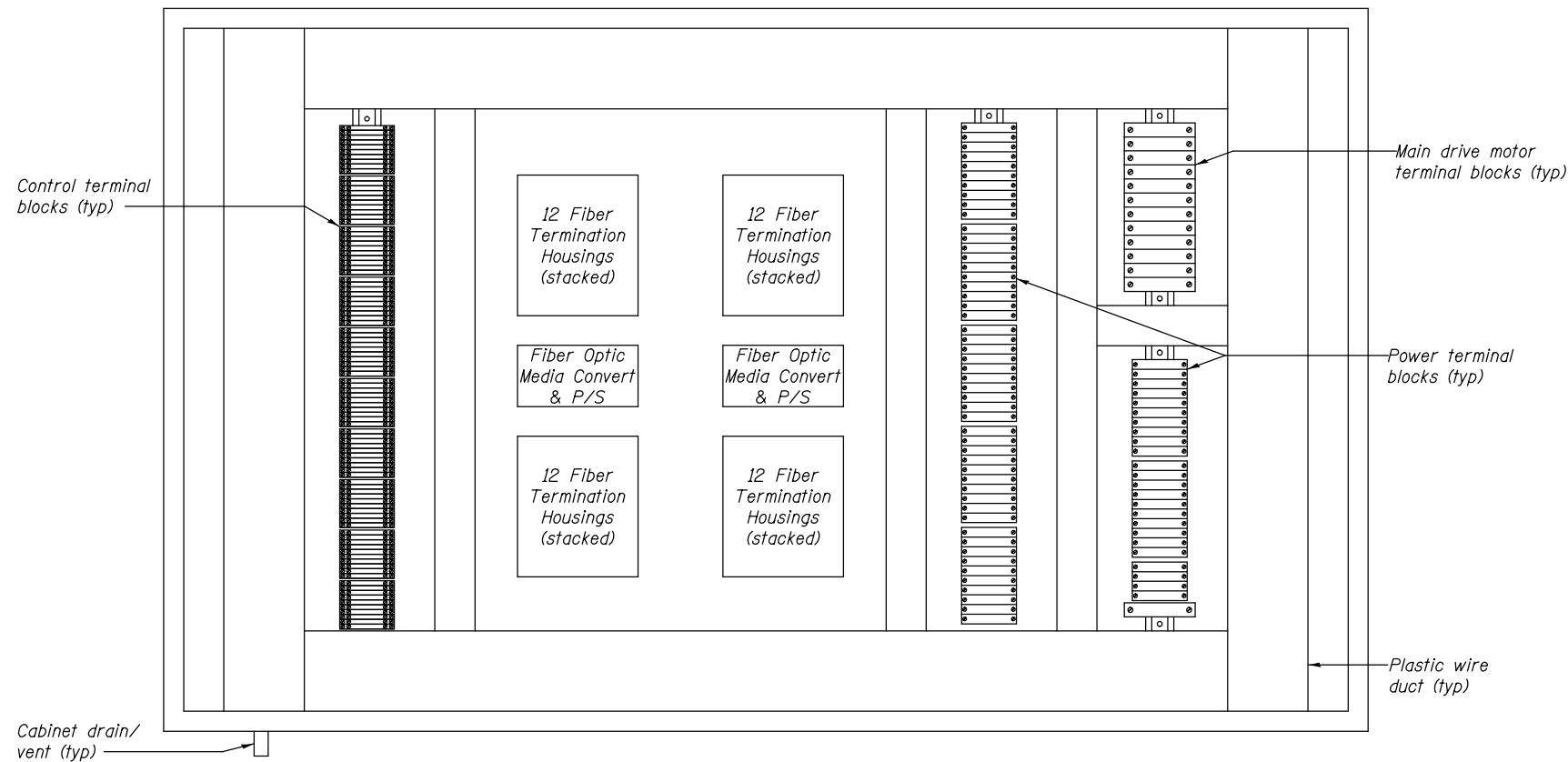

NEARSIDE AERIAL CABLES TERMINAL CABINET LAYOUT, 36"H x 60"W x 12"D

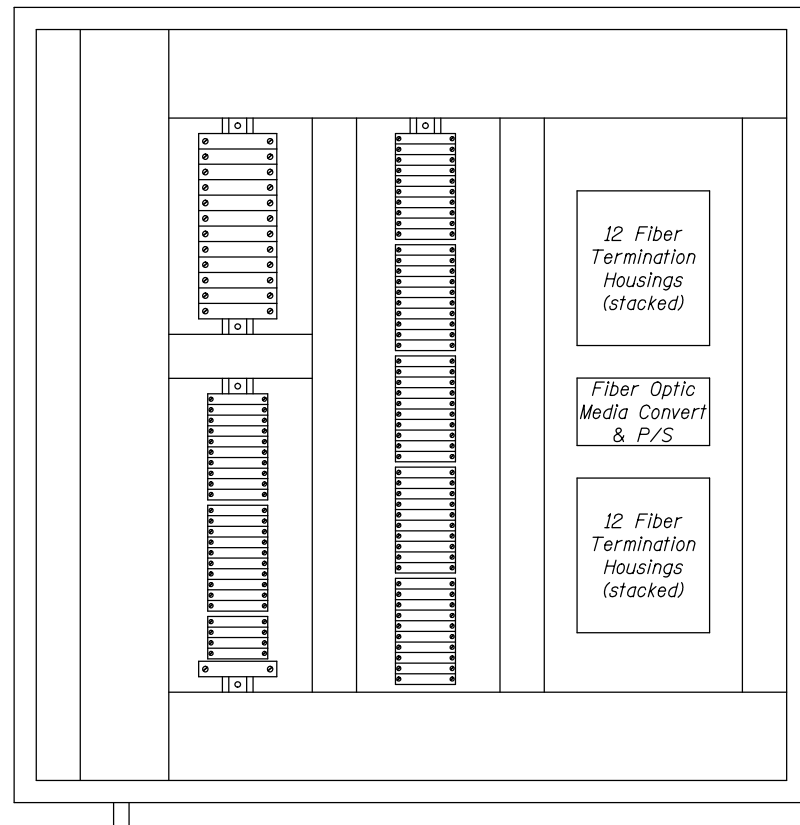

FARSIDE AERIAL CABLES TERMINAL CABINET LAYOUTS, 36"H x 36"W x 12"D

PROPOSED AERIAL CONTROL AND COMMUNICATIONS CABLE		
Description	Quantity	Size/Type
Fiber Optic Communications, Main SCADA & CCTV Networks	1	96 Fiber, SM
Fiber Optic Communications, Local Bridge PLC and CCTV Networks	2	12 Fiber
Farside Motor Encoders	8	1 pair, shielded 12AWG
Farside Inclinator and Spares	7	1 pair, shielded 12AWG
Farside Traffic Gate Limit Switches	10	10 AWG
Farside Fully Seated Limit Switch	2	10 AWG
Farside Rotary Cam Limit Switch	9	10 AWG
Farside Brake Limit Switches	12	10 AWG
Farside Boat Detection	2	10 AWG
Motor Heater Control and Thermostat Contacts	8	10 AWG
Spare	17	10 AWG
Ground	1	6 AWG

PROPOSED AERIAL POWER & MAIN DRIVE CABLE		
Description	Quantity	Size/Type
Fiber Optic Communications, Main SCADA & CCTV Networks	1	96 Fiber, SM
Fiber Optic Communications, Local Bridge PLC and CCTV Networks	2	12 Fiber
Farside Main Drive Motor 1 - Shielded Symmetrical VFD Cable	1	(3) - 2AWG (3) - Ground
Farside Main Drive Motor 2 - Shielded Symmetrical VFD Cable	1	(3) - 2AWG (3) - Ground
Spare Farside Main Drive Motor- Shielded Symmetrical VFD Cable	1	(3) - 2AWG (3) - Ground
Farside Motors (2 gates, 4 brakes)	18	10 AWG
120 VAC, Farside CCTV/PA	2	6 AWG
120 VAC Power Circuits	39	10 AWG
240 VAC Power	3	4 AWG
Spare	10	10 AWG
Spare	2	4 AWG
Ground	1	2 AWG

**NOTES**

- Aerial cables content, cabinet sizes, and cabinet layouts shown are conceptual. The Contractor shall be responsible for determining the requirements of the aerial cable system necessary to support the Intergrated Bridge Controls System, the Bridge Control CCTV system, and all other related systems and components.
- Refer to Special Provisions for additional requirements for aerial cables and cabinets.
- Provide fiber optic termination housings as required to terminate aerial cable fiber optic cables associated with bridge local networks and to interconnect all associated bridge devices and networked components.
- For 96 fiber single mode cables in aerial cable assemblies utilized for the CCTV and SCADA networks interconnecting the six movable bridges and the Bridge Office, provide fiber optic cables with sufficient excess length on both ends required to connect (via conduit routing) to the appropriate Fiber Optic Interconnect Cabinets. Provide a minimum of 300' for the operator house end and 700' for the opposite end of each cable. Additional fiber optic slack shall be provided for each of the following: 100 feet at each termination point, 50 feet at each junction box.



USER NAME =	DESIGNED - R.I. PETERS	REVISED -
	CHECKED - L.V. BORDEN	REVISED -
PLOT SCALE =	DRAWN - R.I. PETERS	REVISED -
PLOT DATE =	CHECKED - K.M. GABLE	REVISED -

STATE OF ILLINOIS  
DEPARTMENT OF TRANSPORTATION

VARIOUS MOVABLE BRIDGES  
LOCAL CENTRALIZED CONTROL AND OPERATION  
MCDONOUGH STREET - AERIAL CABLE DETAILS  
SHEET NO. 37 OF 40 SHEETS

McDONOUGH, Drawing 05-037			
F.A.U. RTE.	SECTION	COUNTY	TOTAL SHEETS
0313	2011-045-I	WILL	466
			SHEET NO. 322
CONTRACT NO. 60P55			
ILLINOIS FED. AID PROJECT			

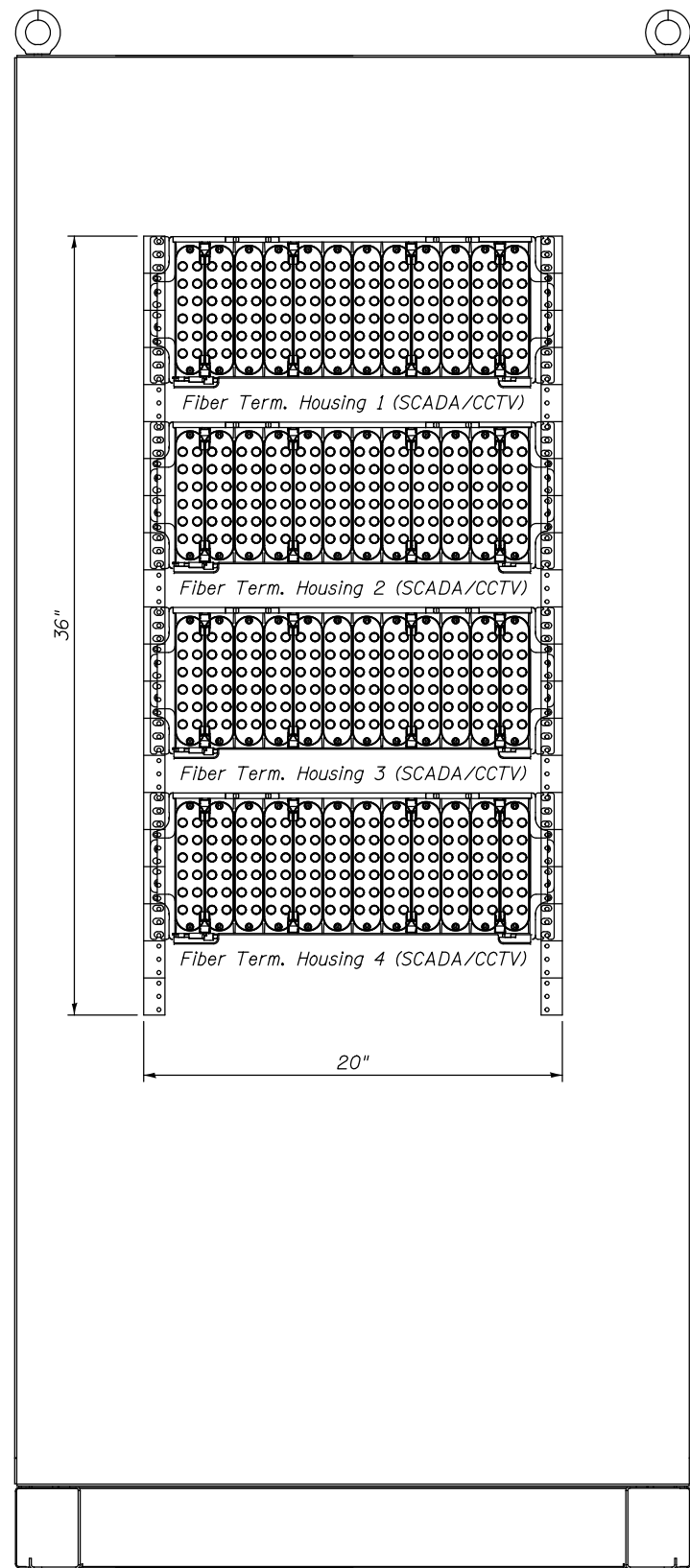

Cabinet dimensions  
72" high x 30" wide x 24" deep

OUTDOOR FIBER OPTIC INTERCONNECT CABINET

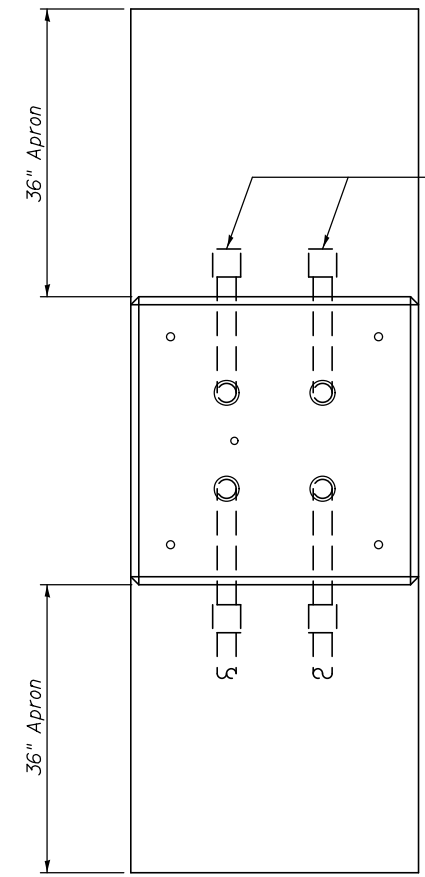

PLAN

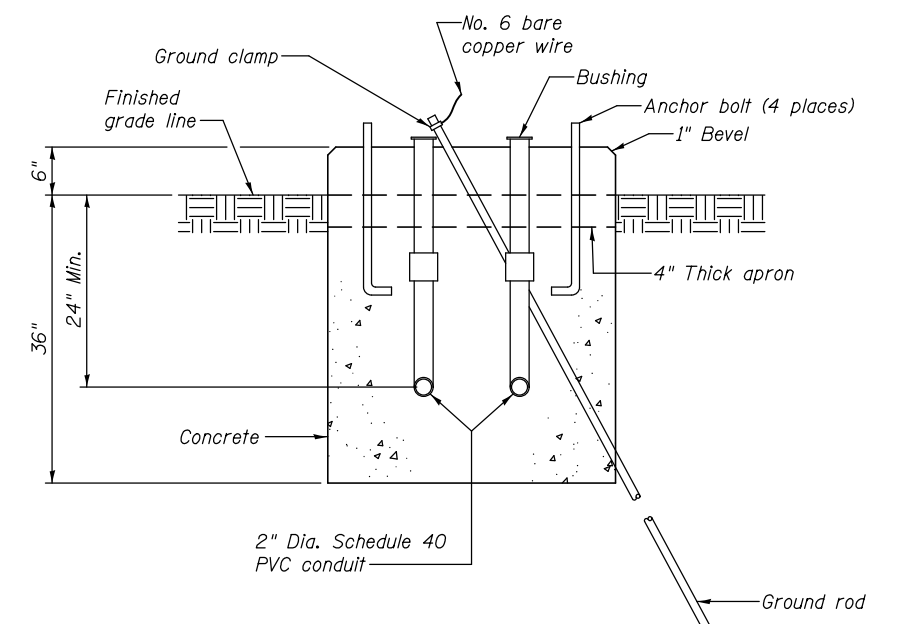

CONCRETE FOUNDATION SPECIAL FOR GROUND MOUNTED CABINET

**NOTES:**

1. Rack and cabinet layouts shown are conceptual. The contractor shall be responsible for developing and submitting layouts with all required components.
2. Provide patch cables to interconnect all 96 fibers of main network cables between locations.



USER NAME =	DESIGNED - R.I. PETERS	REVISED -
	CHECKED - L.V. BORDEN	REVISED -
PLOT SCALE =	DRAWN - R.I. PETERS	REVISED -
PLOT DATE =	CHECKED - K.M. GABLE	REVISED -

STATE OF ILLINOIS  
DEPARTMENT OF TRANSPORTATION

VARIOUS MOVABLE BRIDGES  
LOCAL CENTRALIZED CONTROL AND OPERATION  
MCDONOUGH STREET - FIBER OPTIC OUTDOOR INTERCONNECT CABINET  
SHEET NO. 38 OF 40 SHEETS

McDONOUGH, Drawing 05-038				
F.A.U. RTE.	SECTION	COUNTY	TOTAL SHEETS	SHEET NO.
0313	2011-045-I	WILL	466	323
CONTRACT NO. 60P55				
ILLINOIS FED. AID PROJECT				

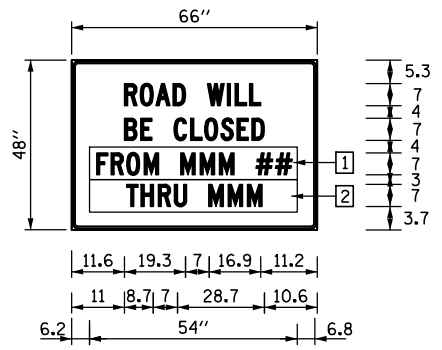

- ARTERIAL ROAD INFORMATION SIGN NOTES:**
- SIGN SHALL BE PAID FOR AS TEMPORARY INFORMATION SIGNING. ONE SIGN ASSEMBLY EQUALS 27.3 SQ FT.
  - OVERLAY PANELS SHALL BE "HIGHWAY C" FONT
  - OVERLAY PANEL 1 TO CONTAIN STARTING DATE OF FULL CLOSURE AND DETOUR IMPLEMENTATION
  - OVERLAY PANEL 2 TO CONTAIN ENDING MONTH OF FULL CLOSURE AND DETOUR. OMIT THE DATE ON PANEL; MONTH ONLY.
  - ERECT SIGN ASSEMBLY (POST-MOUNTED) WITH PANELS 1 AND 2 IN PLACE ON ROAD TO BE CLOSED IN EACH DIRECTION NEAR POINT OF CLOSURE OR WITHIN SECTION TO BE FULLY CLOSED TWO (2) WEEKS PRIOR TO START DATE OF FULL CLOSURE. REMOVE ASSEMBLY AFTER CLOSURE.

ARTERIAL ROAD INFORMATION SIGN FOR ROADS TO BE FULLY CLOSED AND DETOURED  
6'R, 1.3" BORDER, BLACK ON ORANGE

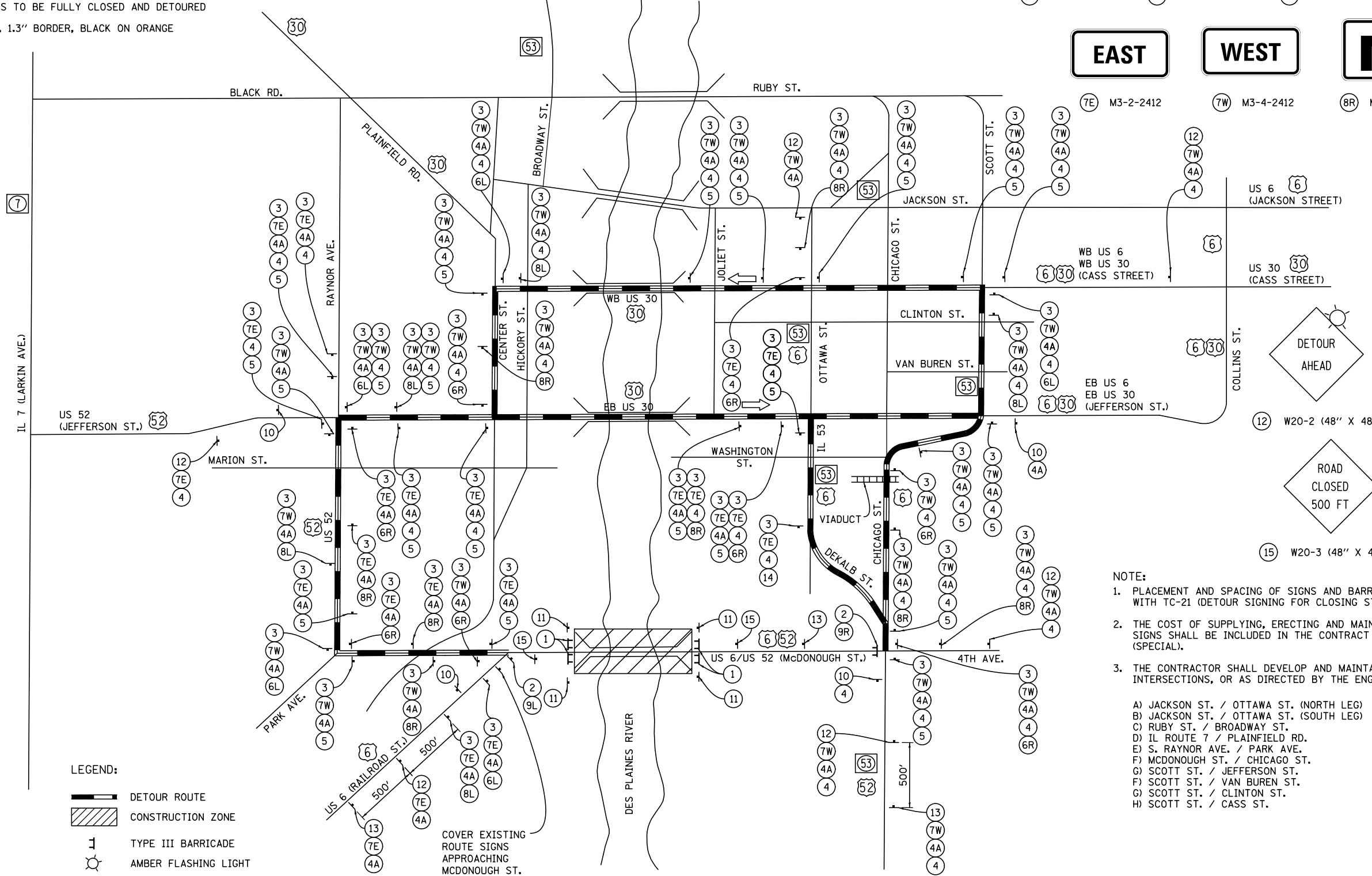
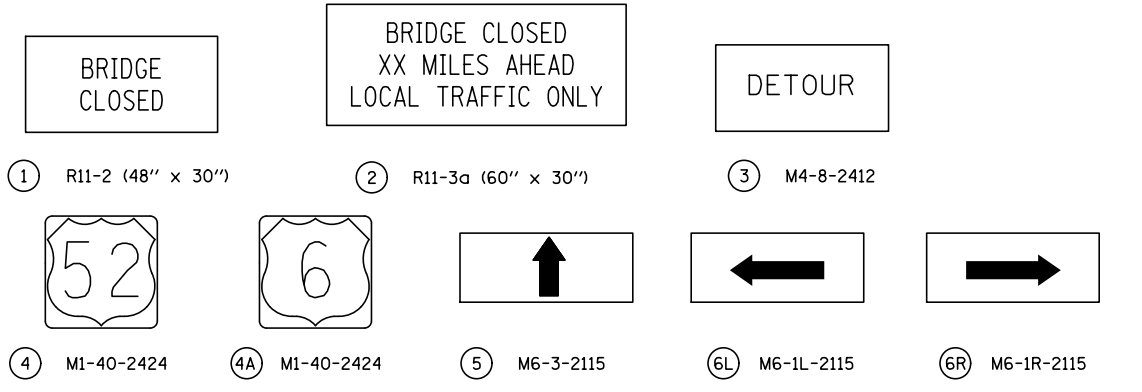

- LEGEND:**
- DETOUR ROUTE
  - CONSTRUCTION ZONE
  - TYPE III BARRICADE
  - AMBER FLASHING LIGHT

COVER EXISTING ROUTE SIGNS APPROACHING MCDONOUGH ST.

- NOTE:**
- PLACEMENT AND SPACING OF SIGNS AND BARRICADES SHALL BE IN ACCORDANCE WITH TC-21 (DETOUR SIGNING FOR CLOSING STATE HIGHWAYS).
  - THE COST OF SUPPLYING, ERECTING AND MAINTAINING BARRICADES, WARNING LIGHTS AND SIGNS SHALL BE INCLUDED IN THE CONTRACT COST OF TRAFFIC CONTROL AND PROTECTION (SPECIAL).
  - THE CONTRACTOR SHALL DEVELOP AND MAINTAIN APPROPRIATE SIGNAL TIMINGS FOR THE FOLLOWING INTERSECTIONS, OR AS DIRECTED BY THE ENGINEER.

- |   |                                   |
|---|-----------------------------------|
| A) JACKSON ST. / OTTAWA ST. (NORTH LEG) | I) CASS ST. / CHICAGO ST.         |
| B) JACKSON ST. / OTTAWA ST. (SOUTH LEG) | J) CASS ST. / OTTAWA ST.          |
| C) RUBY ST. / BROADWAY ST.              | K) CASS ST. / JOLIET ST.          |
| D) IL ROUTE 7 / PLAINFIELD RD.          | L) CASS ST. / HICKORY ST.         |
| E) S. RAYNOR AVE. / PARK AVE.           | M) CASS ST. / CENTER ST.          |
| F) MCDONOUGH ST. / CHICAGO ST.          | N) CENTER ST. / JEFFERSON ST.     |
| G) SCOTT ST. / JEFFERSON ST.            | O) S. RAYNOR AVE. / MARION AVE.   |
| F) SCOTT ST. / VAN BUREN ST.            | P) S. RAYNOR AVE. / JEFFERSON ST. |
| G) SCOTT ST. / CLINTON ST.              | Q) JEFFERSON ST. / HICKORY ST.    |
| H) SCOTT ST. / CASS ST.                 | R) JEFFERSON ST. / JOLIET ST.     |
|   | S) JEFFERSON ST. / OTTAWA ST.     |
|   | T) OTTAWA ST. / WASHINGTON ST.    |



USER NAME =	DESIGNED - MAG	REVISED
	CHECKED - RAG	REVISED
PLOT SCALE =	DRAWN - MAG	REVISED
PLOT DATE =	CHECKED - T.P. LAVIN	REVISED



**STATE OF ILLINOIS  
DEPARTMENT OF TRANSPORTATION**

**VARIOUS MOVABLE BRIDGES  
LOCAL CENTRALIZED CONTROL AND OPERATION  
MCDONOUGH STREET - S.N. 099-9904 DETOUR ROUTE - 1**  
SHEET NO. 39 OF 40 SHEETS





MCDONOUGH, Drawing 05-039			
F.A.U. RTE.	SECTION	COUNTY	TOTAL SHEETS
0313	2011-045-I	WILL	466
			SHEET NO. 324
CONTRACT NO. 60P55			
ILLINOIS FED. AID PROJECT			







**ROUTE MARKERS**

-  FOR U.S. ROUTES  
M1-40-2424
-  FOR ILLINOIS ROUTES  
M1-50-2424
-  R.R. UNMARKED ROUTES  
SPECIAL 24" x 18" VARIABLE  
4" BLACK LETTERS ON WHITE  
REFLECTIVE BACKGROUND

**ARROWS SIGNS**

-  M5-1L-2115
-  M5-1R-2115
-  M6-1-2115
-  M6-1-2115
-  M6-3-2115

**CARDINAL DIRECTION & DETOUR SIGNS**

-  NORTH M3-1-2412
-  EAST M3-2-2412
-  SOUTH M3-3-2412
-  WEST M3-4-2412
-  DETOUR M4-8-2412

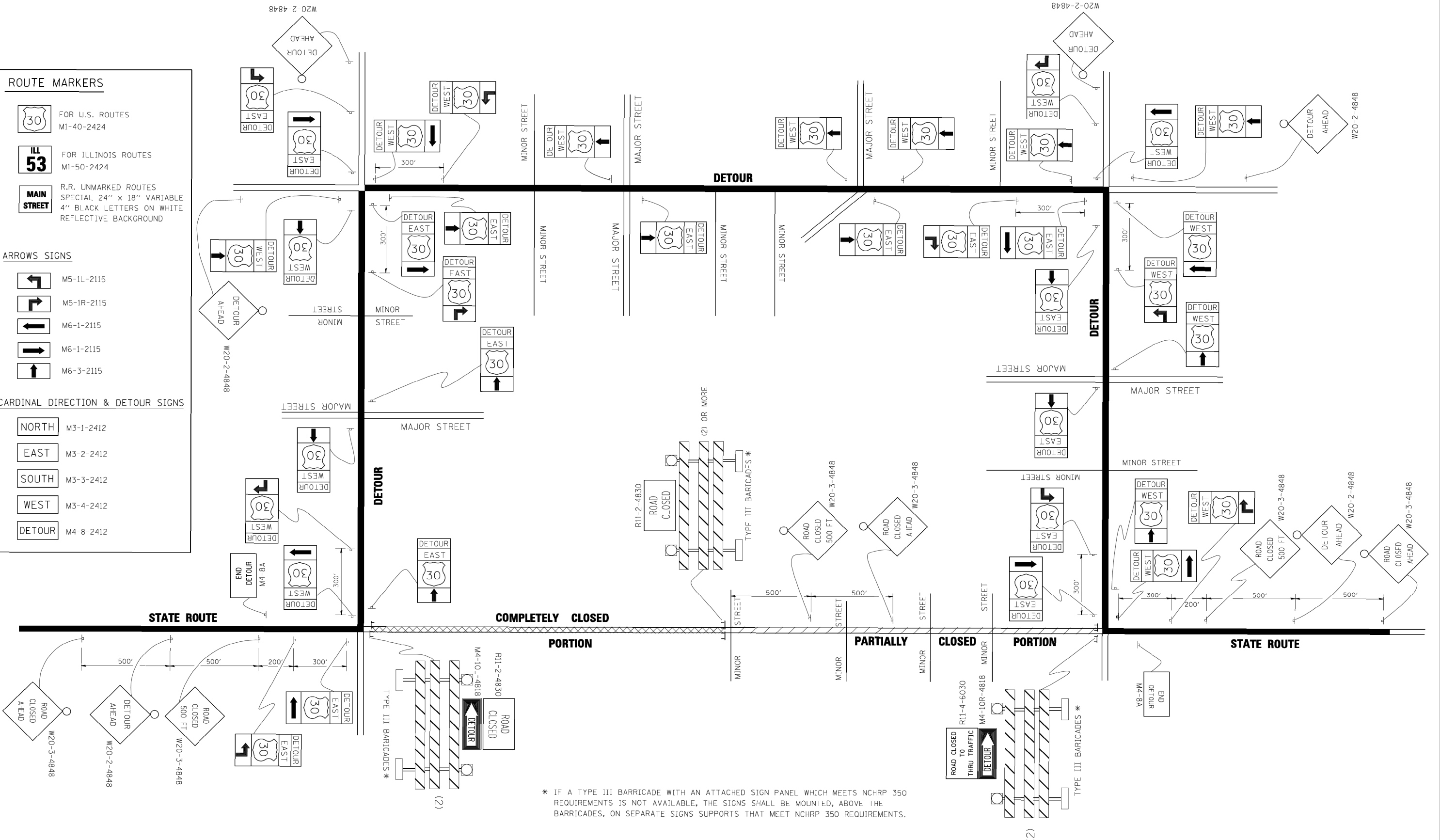

\* IF A TYPE III BARRICADE WITH AN ATTACHED SIGN PANEL WHICH MEETS NCHRP 350 REQUIREMENTS IS NOT AVAILABLE, THE SIGNS SHALL BE MOUNTED, ABOVE THE BARRICADES, ON SEPARATE SIGNS SUPPORTS THAT MEET NCHRP 350 REQUIREMENTS.

**IDOT DISTRICT 1 STANDARD TC-21**



USER NAME =	DESIGNED -	REVISED
	CHECKED -	REVISED
PLOT SCALE =	DRAWN -	REVISED
PLOT DATE =	CHECKED -	REVISED

**STATE OF ILLINOIS  
DEPARTMENT OF TRANSPORTATION**

**VARIOUS MOVABLE BRIDGES  
LOCAL CENTRALIZED CONTROL AND OPERATION  
DETOUR SIGNING FOR CLOSING STATE HIGHWAYS**

F.A.P. RTE.	SECTION	COUNTY	TOTAL SHEETS	SHEET NO.
0313	2011-045-I	WILL	466	325
TC-21			CONTRACT NO. 60P55	
ILLINOIS FED. AID PROJECT				

MCDONOUGH, Drawing 05-040

SHEET NO. 40 OF 40 SHEETS

Benchmark:  
 All elevations are based upon the existing bridge having an elevation of 326.10 at centerline Trunnion as shown on the plans for the existing bridge dated 1933. Illinois Waterway Benchmark #285.8

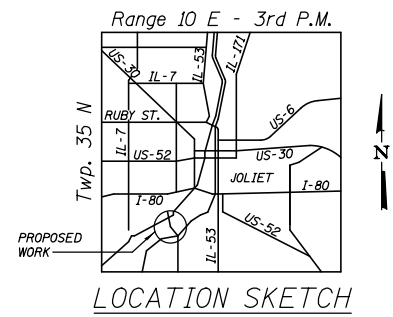
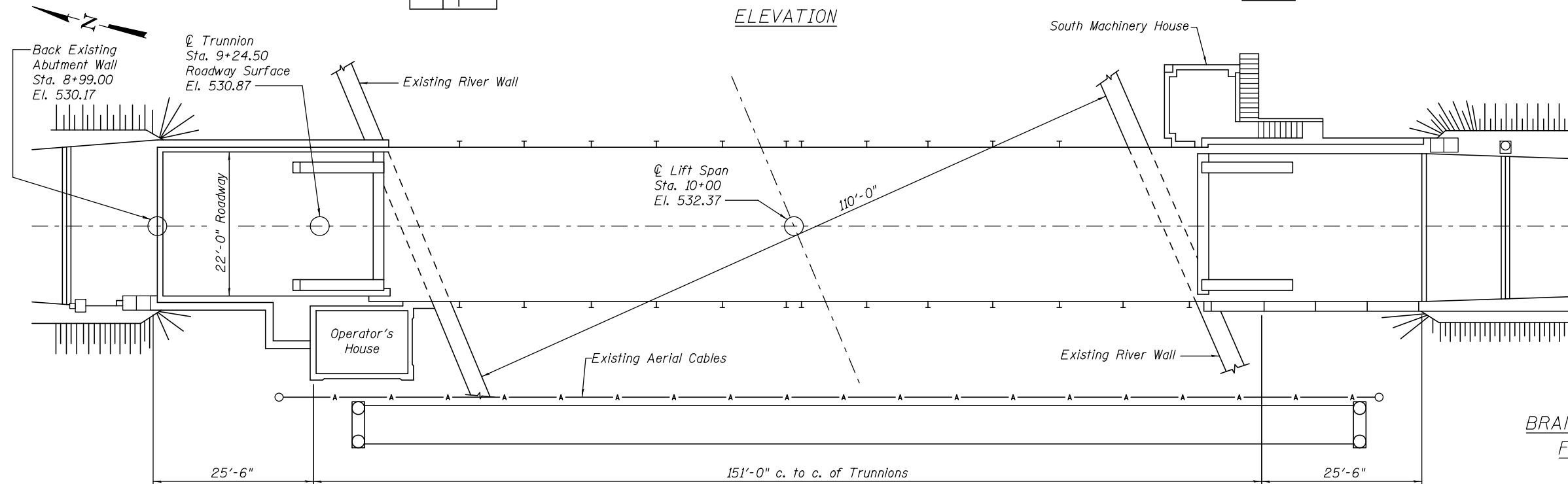
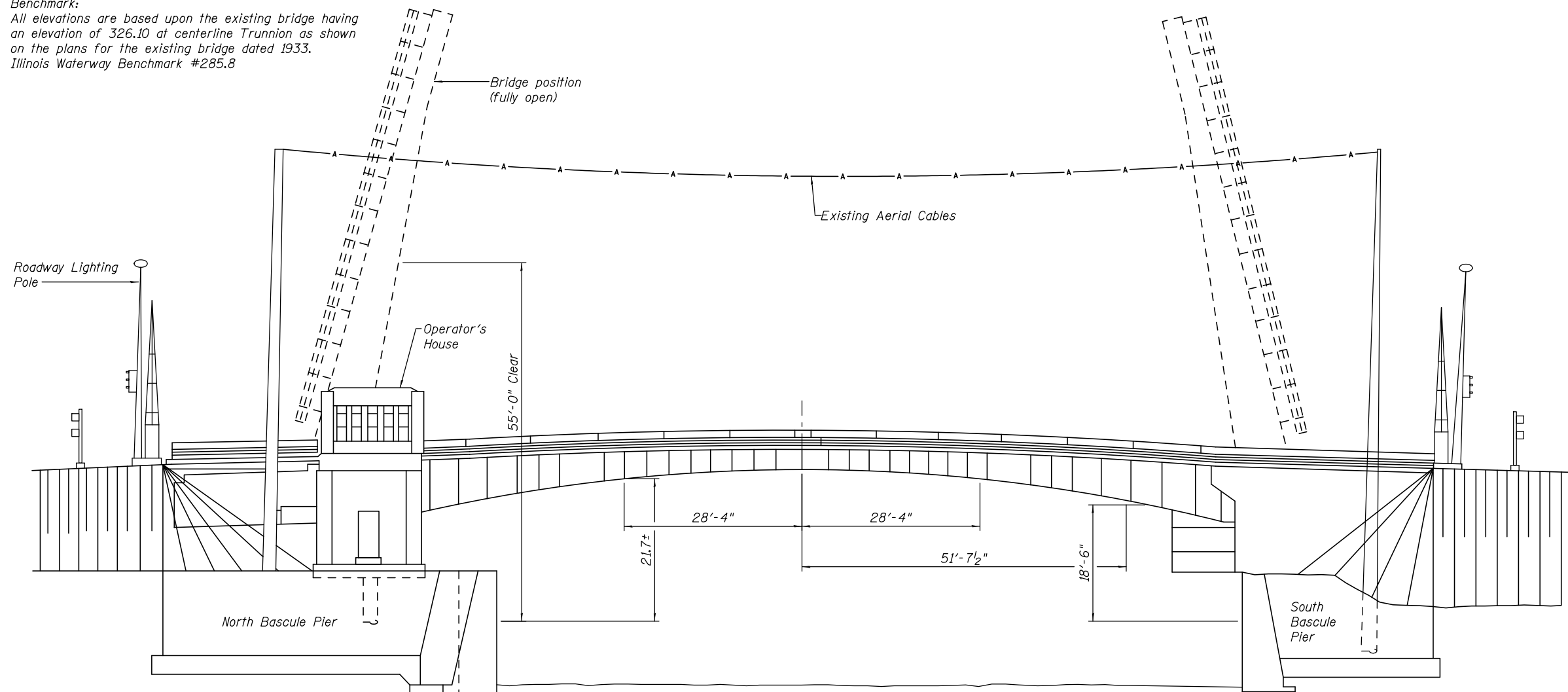

GENERAL PLAN AND ELEVATION  
 BRANDON ROAD OVER DES PLAINES RIVER  
 F.A.U. ROUTE 0341 SEC. 2011-045-I  
 WILL COUNTY  
 STATION 000.120  
 STRUCTURE NO. 099-9903



USER NAME =	DESIGNED - R.I. PETERS	REVISED -
	CHECKED - L.V. BORDEN	REVISED -
PLOT SCALE =	DRAWN - R.S. JOHNSON	REVISED -
PLOT DATE =	CHECKED - R.I. PETERS	REVISED -

STATE OF ILLINOIS  
 DEPARTMENT OF TRANSPORTATION

SHEET NO. 1 OF 93 SHEETS

F.A.U. RTE.	SECTION	COUNTY	TOTAL SHEETS	SHEET NO.
0341	2011-045-I	WILL	466	326
			CONTRACT NO. 60P55	
ILLINOIS FED. AID PROJECT				

BRANDON, Drawing 06-001

# INDEX OF SHEETS

<u>SHEET</u>	<u>LOCAL SHEET</u>	<u>DESCRIPTION</u>
326	06-001	GENERAL PLAN AND ELEVATION
327	06-002	INDEX OF SHEETS
328	06-003	ELECTRICAL SCOPE PLAN AND ELEVATION
329 – 330	06-004 – 06-005	OPERATOR'S HOUSE DETAILS
331	06-006	NEAR SIDE MACHINERY LAYOUT
332	06-007	FAR SIDE MACHINERY LAYOUT
333 – 337	06-008 – 06-012	THREE LINE DIAGRAMS
338	06-013	DISTRIBUTION PANEL LAYOUT
339	06-014	PANELBOARD SCHEDULES
340	06-015	FIBER OPTIC ROUTE TO OPERATOR HOUSE
341	06-016	FIBER OPTIC INTERCONNECT CABINET
342	06-017	SCADA ONE-LINE
343	06-018	CCTV ONE-LINE
344 – 348	06-019 – 06-023	CCTV CAMERA LAYOUTS
349	06-024	PUBLIC ADDRESS SPEAKER LAYOUT
350	06-025	NETWORK CABINET DETAILS
351	06-026	CCTV PLAN AND ELEVATION
352	06-027	CCTV MOUNTING DETAILS
353	06-028	BRIDGE CONTROL DIAGRAM
354 – 355	06-029 – 06-030	NEW BRIDGE CONTROL CONSOLE
356 – 358	06-031 – 06-033	CONTROL CIRCUIT LEGENDS
359 – 405	06-034 – 06-080	CONTROL CIRCUITS
406	06-081	LIMIT SWITCH TRIPPING CHARTS
407	06-082	ELECTRICAL EQUIPMENT SCHEDULE
408 – 410	06-083 – 06-085	CONDUIT DIAGRAMS
411 – 413	06-086 – 06-088	CONDUIT TABULATIONS
414	06-089	AERIAL CABLE DETAILS
415 – 416	06-090 – 06-091	MISCELLANEOUS ELECTRICAL DETAILS
417 – 418	06-092 – 06-093	CONSTRUCTION DETOUR ROUTES

BRANDON, Drawing 06-002

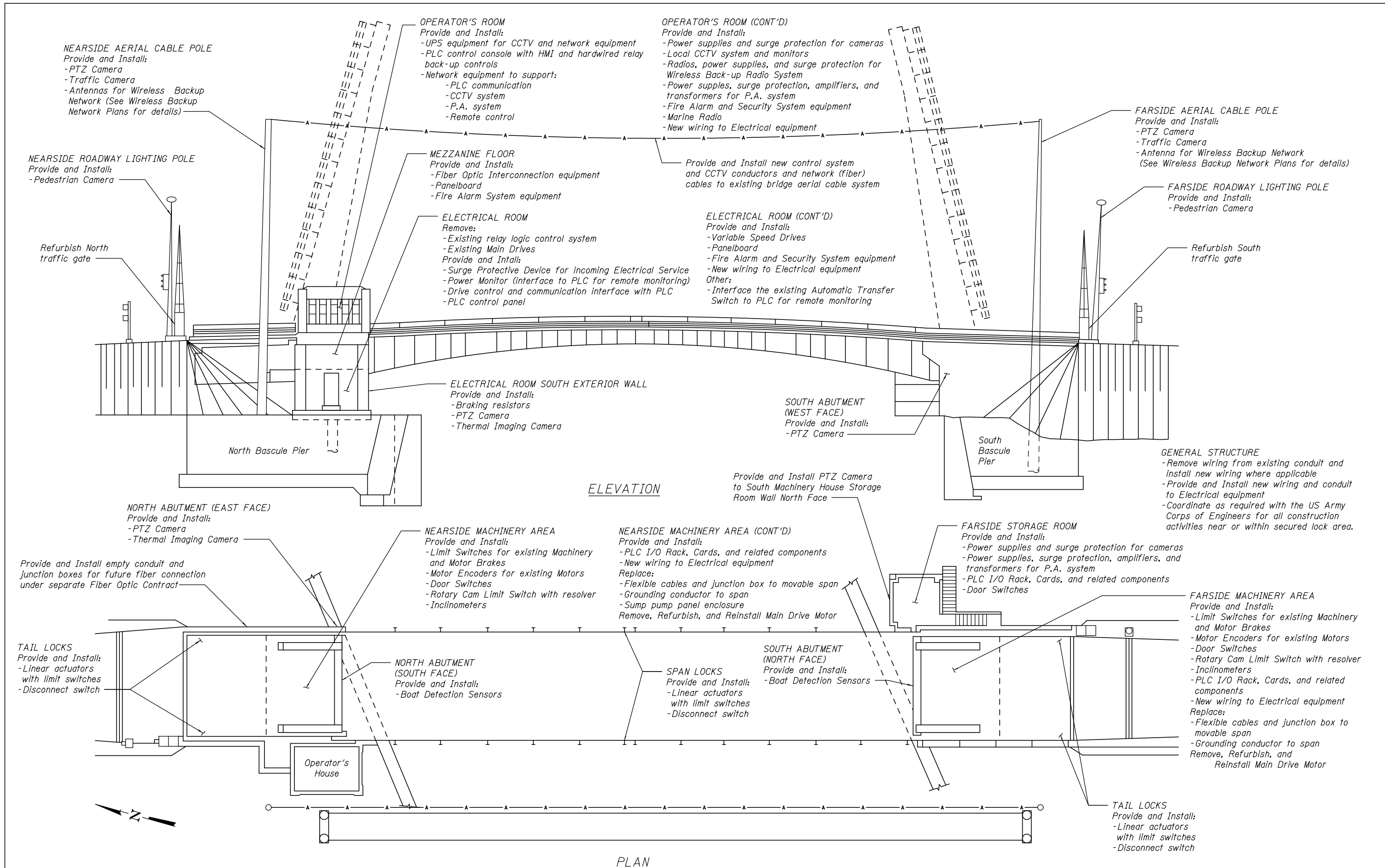

NEARSIDE AERIAL CABLE POLE  
Provide and Install:  
-PTZ Camera  
-Traffic Camera  
-Antennas for Wireless Backup Network (See Wireless Backup Network Plans for details)

NEARSIDE ROADWAY LIGHTING POLE  
Provide and Install:  
-Pedestrian Camera

Refurbish North traffic gate

**OPERATOR'S ROOM**  
Provide and Install:  
-UPS equipment for CCTV and network equipment  
-PLC control console with HMI and hardwired relay back-up controls  
-Network equipment to support:  
-PLC communication  
-CCTV system  
-P.A. system  
-Remote control

**OPERATOR'S ROOM (CONT'D)**  
Provide and Install:  
-Power supplies and surge protection for cameras  
-Local CCTV system and monitors  
-Radios, power supplies, and surge protection for Wireless Back-up Radio System  
-Power supplies, surge protection, amplifiers, and transformers for P.A. system  
-Fire Alarm and Security System equipment  
-Marine Radio  
-New wiring to Electrical equipment

FARSIDE AERIAL CABLE POLE  
Provide and Install:  
-PTZ Camera  
-Traffic Camera  
-Antenna for Wireless Backup Network (See Wireless Backup Network Plans for details)

FARSIDE ROADWAY LIGHTING POLE  
Provide and Install:  
-Pedestrian Camera

Refurbish South traffic gate

**MEZZANINE FLOOR**  
Provide and Install:  
-Fiber Optic Interconnection equipment  
-Panelboard  
-Fire Alarm System equipment

Provide and Install new control system and CCTV conductors and network (fiber) cables to existing bridge aerial cable system

**ELECTRICAL ROOM**  
Remove:  
-Existing relay logic control system  
-Existing Main Drives  
Provide and Install:  
-Surge Protective Device for incoming Electrical Service  
-Power Monitor (interface to PLC for remote monitoring)  
-Drive control and communication interface with PLC  
-PLC control panel

**ELECTRICAL ROOM (CONT'D)**  
Provide and Install:  
-Variable Speed Drives  
-Panelboard  
-Fire Alarm and Security System equipment  
-New wiring to Electrical equipment  
Other:  
-Interface the existing Automatic Transfer Switch to PLC for remote monitoring

**ELECTRICAL ROOM SOUTH EXTERIOR WALL**  
Provide and Install:  
-Braking resistors  
-PTZ Camera  
-Thermal Imaging Camera

**SOUTH ABUTMENT (WEST FACE)**  
Provide and Install:  
-PTZ Camera

**GENERAL STRUCTURE**  
-Remove wiring from existing conduit and install new wiring where applicable  
-Provide and Install new wiring and conduit to Electrical equipment  
-Coordinate as required with the US Army Corps of Engineers for all construction activities near or within secured lock area.

**NORTH ABUTMENT (EAST FACE)**  
Provide and Install:  
-PTZ Camera  
-Thermal Imaging Camera

Provide and Install empty conduit and junction boxes for future fiber connection under separate Fiber Optic Contract

**NEARSIDE MACHINERY AREA**  
Provide and Install:  
-Limit Switches for existing Machinery and Motor Brakes  
-Motor Encoders for existing Motors  
-Door Switches  
-Rotary Cam Limit Switch with resolver  
-Inclinometers

**NEARSIDE MACHINERY AREA (CONT'D)**  
Provide and Install:  
-PLC I/O Rack, Cards, and related components  
-New wiring to Electrical equipment  
Replace:  
-Flexible cables and junction box to movable span  
-Grounding conductor to span  
-Sump pump panel enclosure  
Remove, Refurbish, and Reinstall Main Drive Motor

**FARSIDE STORAGE ROOM**  
Provide and Install:  
-Power supplies and surge protection for cameras  
-Power supplies, surge protection, amplifiers, and transformers for P.A. system  
-PLC I/O Rack, Cards, and related components  
-Door Switches

**FARSIDE MACHINERY AREA**  
Provide and Install:  
-Limit Switches for existing Machinery and Motor Brakes  
-Motor Encoders for existing Motors  
-Door Switches  
-Rotary Cam Limit Switch with resolver  
-Inclinometers  
-PLC I/O Rack, Cards, and related components  
-New wiring to Electrical equipment  
Replace:  
-Flexible cables and junction box to movable span  
-Grounding conductor to span  
Remove, Refurbish, and Reinstall Main Drive Motor

**TAIL LOCKS**  
Provide and Install:  
-Linear actuators with limit switches  
-Disconnect switch

**NORTH ABUTMENT (SOUTH FACE)**  
Provide and Install:  
-Boat Detection Sensors

**SPAN LOCKS**  
Provide and Install:  
-Linear actuators with limit switches  
-Disconnect switch

**SOUTH ABUTMENT (NORTH FACE)**  
Provide and Install:  
-Boat Detection Sensors

**TAIL LOCKS**  
Provide and Install:  
-Linear actuators with limit switches  
-Disconnect switch



USER NAME =	DESIGNED - K.M. GABLE	REVISED	___
	CHECKED - L.V. BORDEN	REVISED	___
PLOT SCALE =	DRAWN - R.S. JOHNSON	REVISED	___
PLOT DATE =	CHECKED - R.I. PETERS	REVISED	___

STATE OF ILLINOIS  
DEPARTMENT OF TRANSPORTATION

VARIOUS MOVABLE BRIDGES  
LOCAL CENTRALIZED CONTROL AND OPERATION  
BRANDON ROAD - ELECTRICAL SCOPE PLAN AND ELEVATION  
SHEET NO. 3 OF 93 SHEETS

BRANDON, Drawing 06-003			
F.A.U. RTE.	SECTION	COUNTY	TOTAL SHEETS
0341	2011-045-I	WILL	466
			SHEET NO. 328
CONTRACT NO. 60P55			
ILLINOIS FED. AID PROJECT			

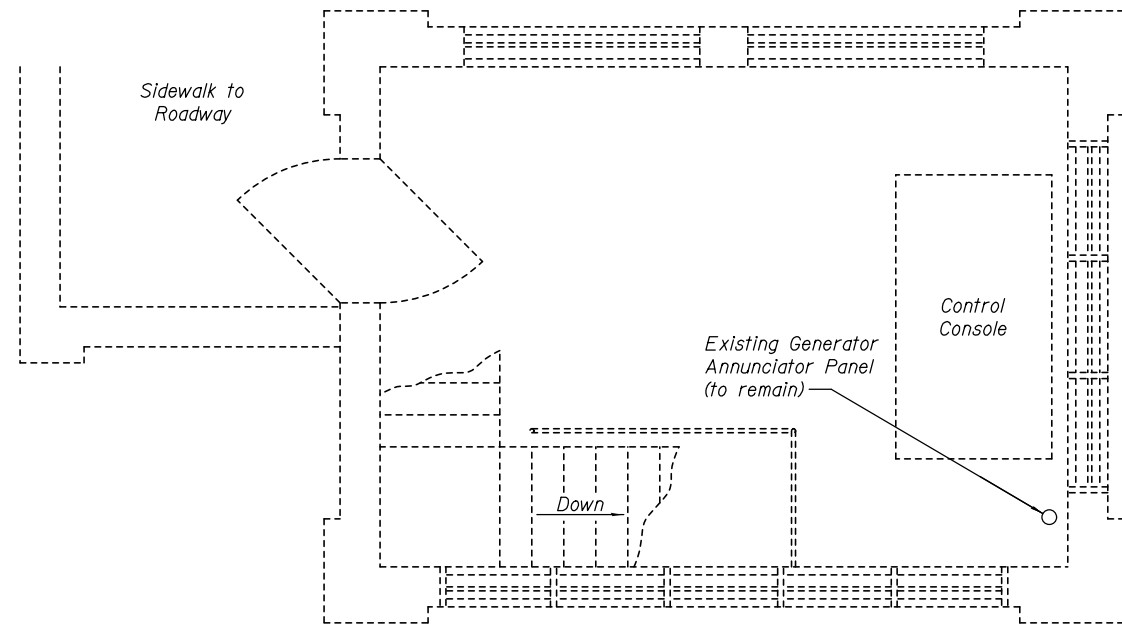



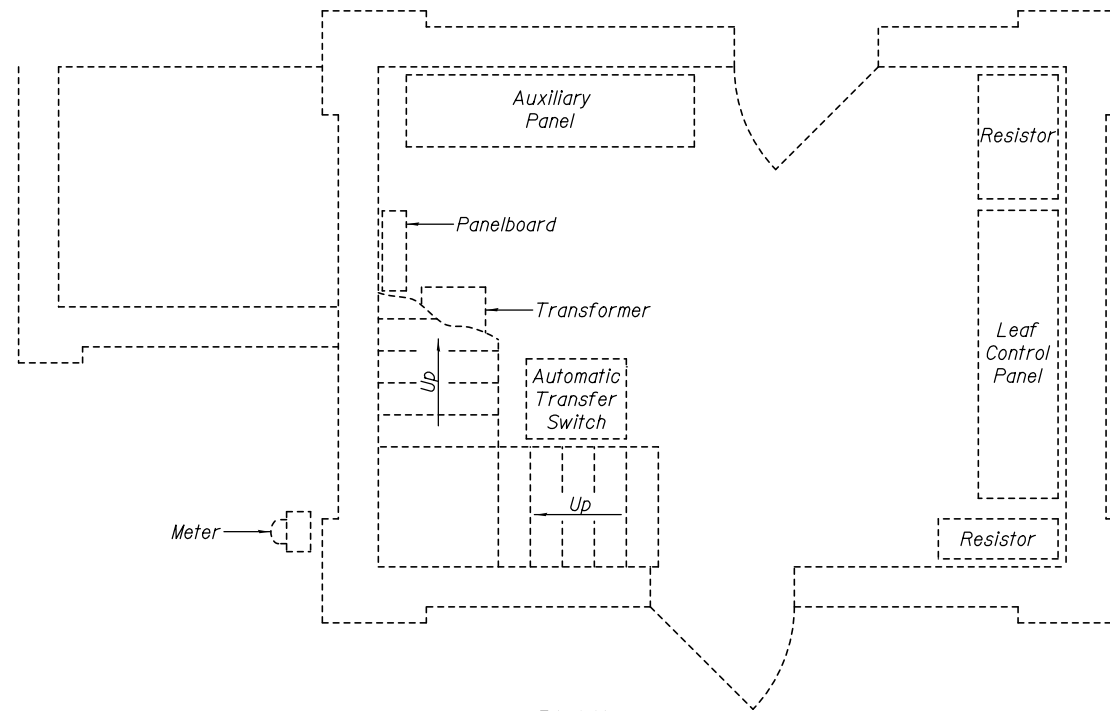

PLAN  
EXISTING OPERATOR'S ROOM FLOOR LAYOUT

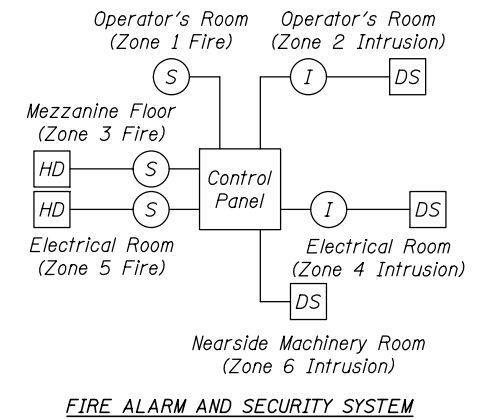

PLAN  
EXISTING BASEMENT ELECTRICAL ROOM LAYOUT



LEGEND

-  Smoke Detector
-  Intrusion Detector
-  Heat Detector
-  Door Switch

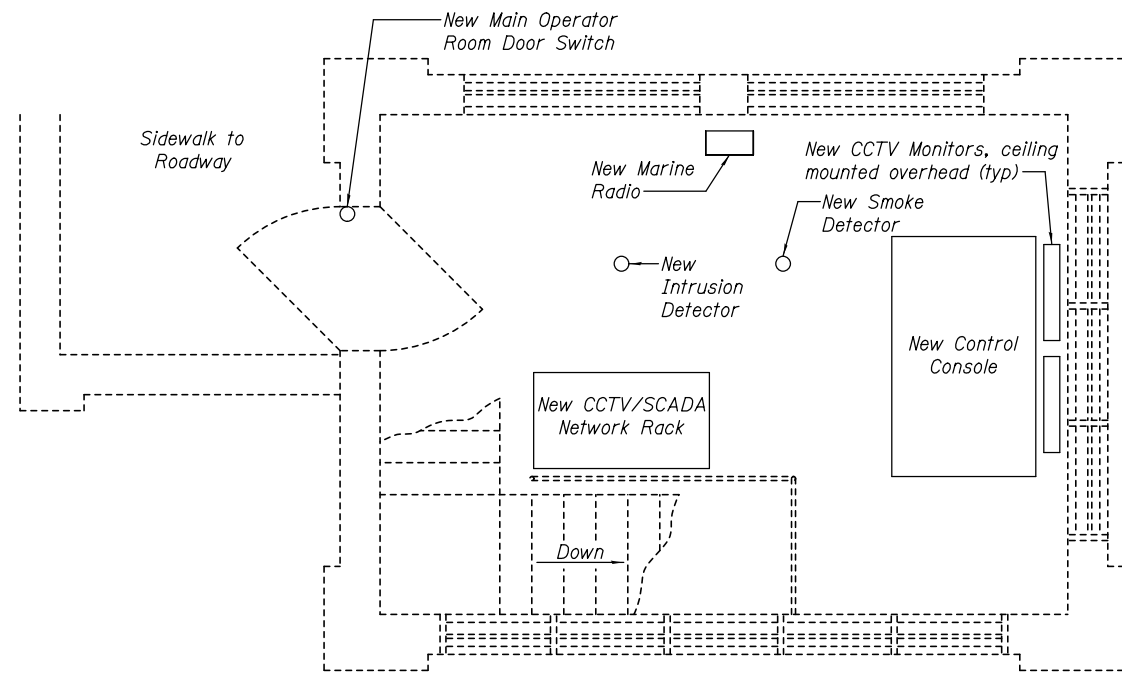
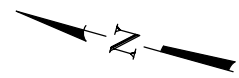

PLAN  
PROPOSED OPERATOR'S ROOM FLOOR LAYOUT

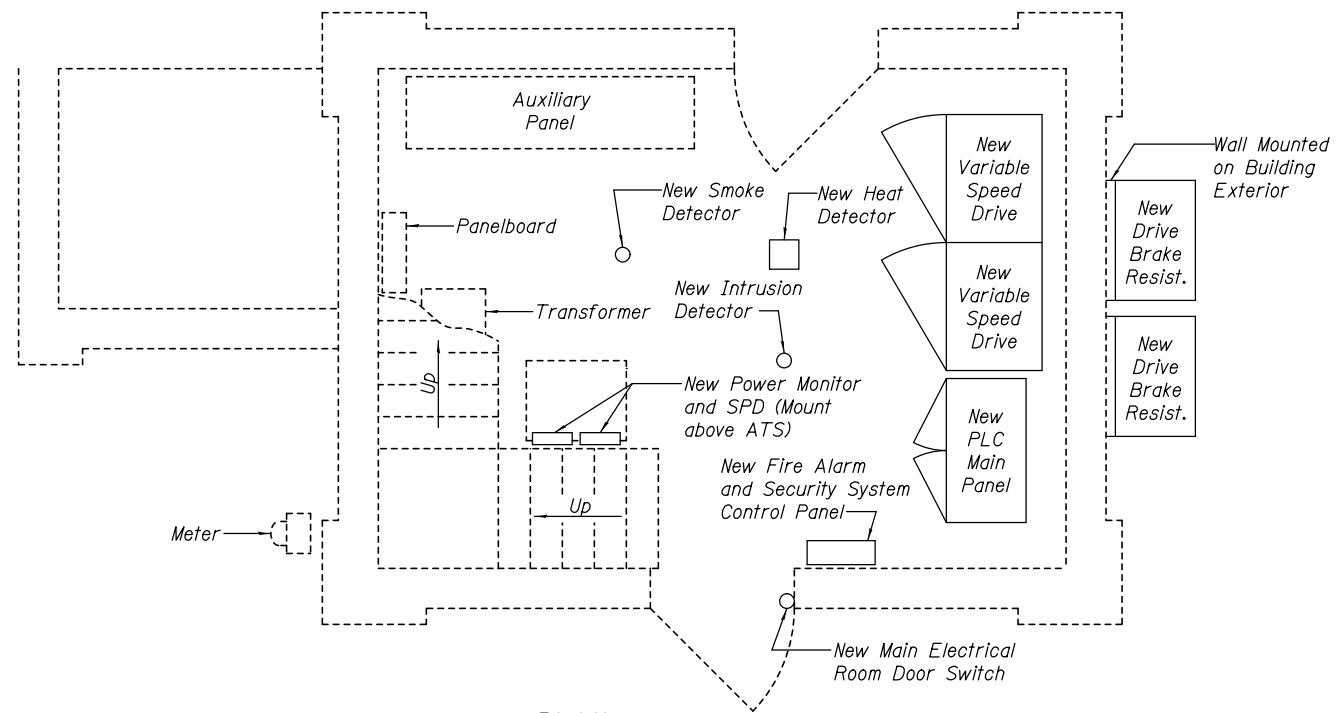

PLAN  
PROPOSED BASEMENT ELECTRICAL ROOM LAYOUT



USER NAME =	DESIGNED - R.I. PETERS	REVISED -
	CHECKED - L.V. BORDEN	REVISED -
PLOT SCALE =	DRAWN - R.L. REED	REVISED -
PLOT DATE =	CHECKED - R.I. PETERS	REVISED -

STATE OF ILLINOIS  
DEPARTMENT OF TRANSPORTATION

VARIOUS MOVABLE BRIDGES  
LOCAL CENTRALIZED CONTROL AND OPERATION  
BRANDON ROAD - OPERATOR'S HOUSE DETAILS - 1

SHEET NO. 4 OF 93 SHEETS

BRANDON, Drawing 06-004				
F.A.U. RTE.	SECTION	COUNTY	TOTAL SHEETS	SHEET NO.
0341	2011-045-I	WILL	466	329
CONTRACT NO. 60P55				
ILLINOIS FED. AID PROJECT				

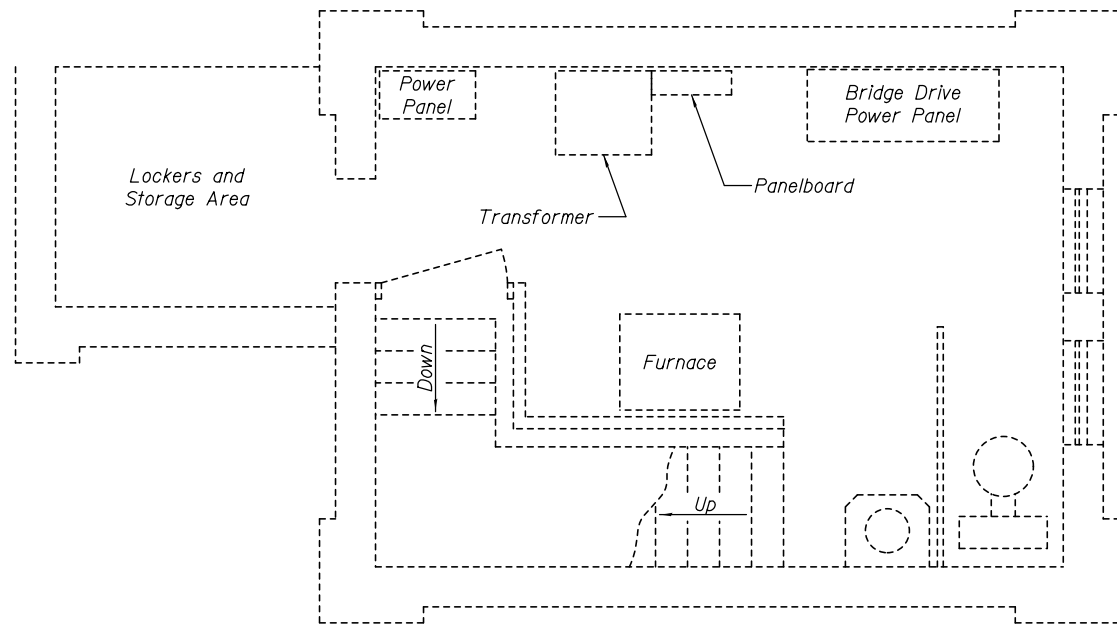

PLAN  
EXISTING MEZZANINE FLOOR LAYOUT

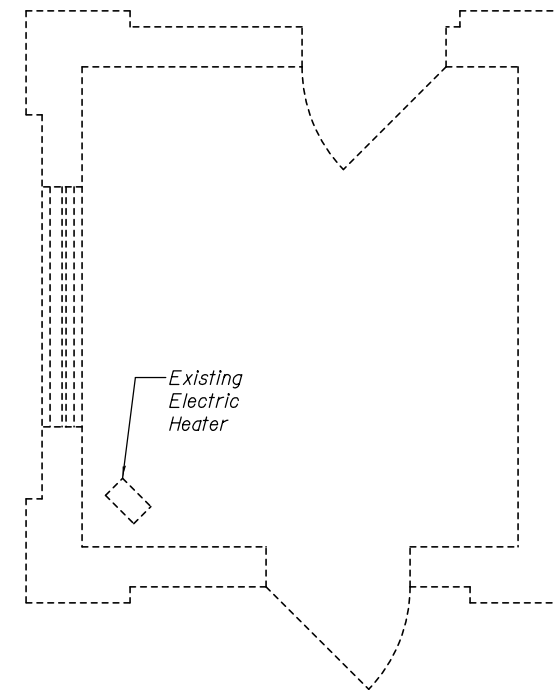

PLAN  
EXISTING FARSIDE STORAGE ROOM LAYOUT

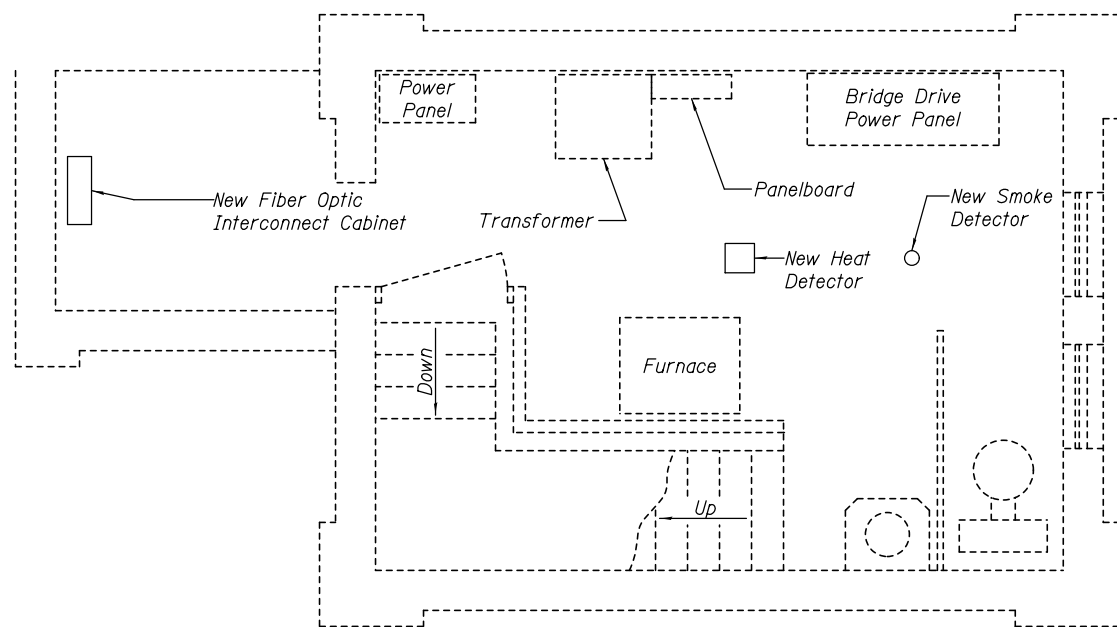

PLAN  
PROPOSED MEZZANINE FLOOR LAYOUT

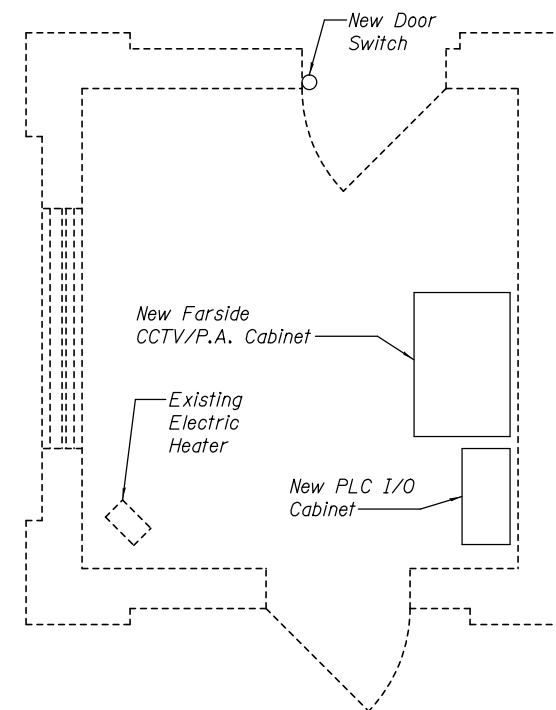

PLAN  
PROPOSED FARSIDE STORAGE ROOM LAYOUT



USER NAME =	DESIGNED - R.I. PETERS	REVISED -
	CHECKED - L.V. BORDEN	REVISED -
PLOT SCALE =	DRAWN - R.L. REED	REVISED -
PLOT DATE =	CHECKED - R.I. PETERS	REVISED -

STATE OF ILLINOIS  
DEPARTMENT OF TRANSPORTATION

VARIOUS MOVABLE BRIDGES  
LOCAL CENTRALIZED CONTROL AND OPERATION  
BRANDON ROAD - OPERATOR'S HOUSE DETAILS - 2  
SHEET NO. 5 OF 93 SHEETS

F.A.U. RTE.		SECTION	COUNTY	TOTAL SHEETS	SHEET NO.
0341		2011-045-I	WILL	466	330
CONTRACT NO. 60P55					
ILLINOIS FED. AID PROJECT					

BRANDON, Drawing 06-005

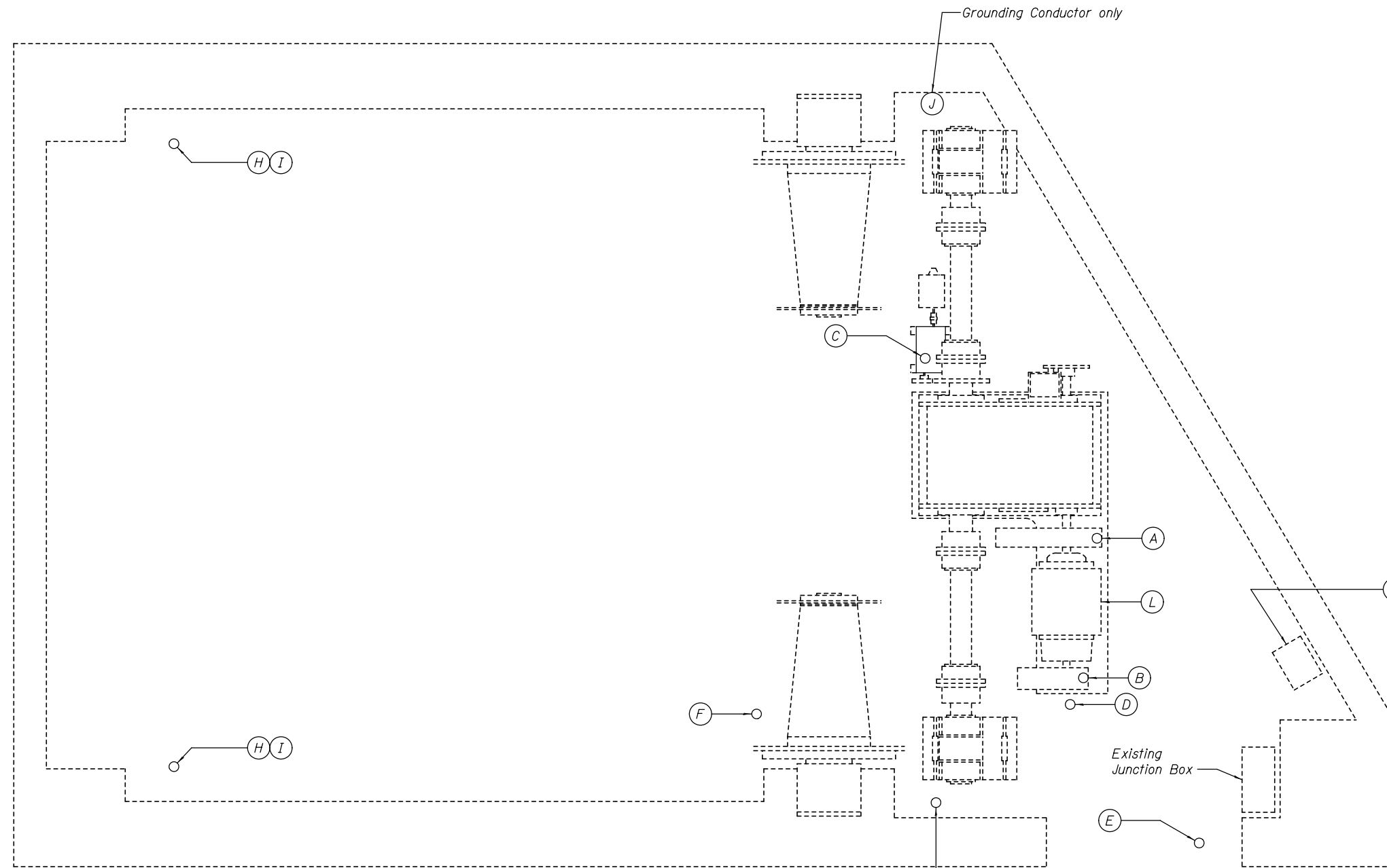
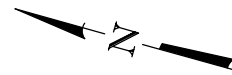

(G) (I)



(G) (I)

- (A) Provide and install new brake set, brake released, and brake hand released Limit Switches for existing Machinery Brake (E208).
- (B) Provide and install new brake set, brake released, and brake hand released Limit Switches for existing Motor Brake (E208).
- (C) Provide and install new Span Position Rotary Cam Limit Switch and Resolver (E206).
- (D) Provide and install new Motor Encoder for existing Motor.
- (E) Provide and install new Door Switch (E210).
- (F) Provide and install new Inclinometers (2) on Span (E207).
- (G) Provide and install new linear actuators with limit switches for existing span locks (on Span) (E212).
- (H) Provide and install new linear actuators with limit switches for existing tail locks (E213).
- (I) Provide and install new lock disconnect switch (E106).
- (J) Replace flexible cables, grounding conductor, and junction box to movable span. Provide and install new strain relief grips for flexible cables.
- (K) Replace sump pump starter enclosure.
- (L) Remove, refurbish, and reinstall main drive motor.

**PLAN  
MACHINERY ROOM**

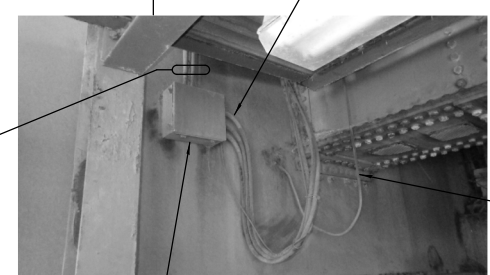

Reroute conduit to enter side or bottom of Junction Box

Provide and install new Strain Relief Grips for flexible cables at connection to Junction Box

Replace Junction Box and provide hooded cover

Grounding Conductor typical of both sides of Machinery Area. Size new in-kind to existing



USER NAME =	DESIGNED - R.I. PETERS	REVISED	___
	CHECKED - L.V. BORDEN	REVISED	___
PLOT SCALE =	DRAWN - R.L. REED	REVISED	___
PLOT DATE =	CHECKED - R.I. PETERS	REVISED	___

**STATE OF ILLINOIS  
DEPARTMENT OF TRANSPORTATION**

**VARIOUS MOVABLE BRIDGES  
LOCAL CENTRALIZED CONTROL AND OPERATION  
BRANDON ROAD - NEARSIDE MACHINERY ROOM LAYOUT**

SHEET NO. 6 OF 93 SHEETS

BRANDON, Drawing 06-006				
F.A.U. RTE.	SECTION	COUNTY	TOTAL SHEETS	SHEET NO.
0341	2011-045-I	WILL	466	331
CONTRACT NO. 60P55				
ILLINOIS FED. AID PROJECT				

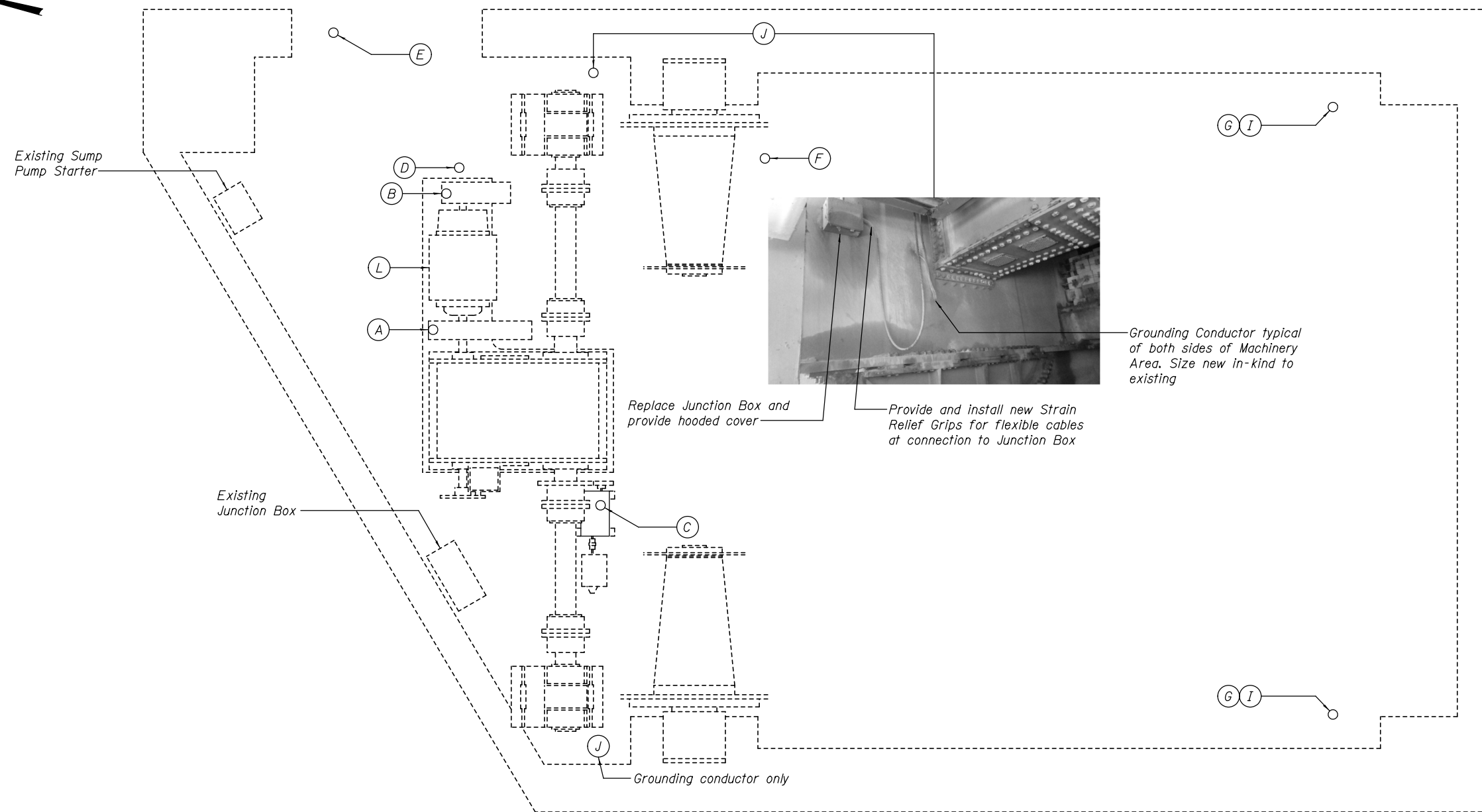
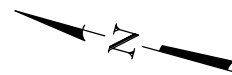

PLAN  
MACHINERY ROOM

- (A) Provide and install new brake set, brake released, and brake hand released Limit Switches for existing Machinery Brake (E208).
- (B) Provide and install new brake set, brake released, and brake hand released Limit Switches for existing Motor Brake (E208).
- (C) Provide and install new Span Position Rotary Cam Limit Switch and Resolver (E206).
- (D) Provide and install new Motor Encoder for existing Motor.
- (E) Provide and install new Door Switch (E210).
- (F) Provide and install new Inclometers (2) on Span (E207).
- (G) Provide and install new linear actuators with limit switches for existing tail locks (E213).
- (I) Provide and install new lock disconnect switch (E106).
- (J) Replace flexible cable, grounding conductor, and junction box to movable span. Provide and install new strain relief grip for flexible cable.
- (L) Remove, refurbish, and reinstall main drive motor.



USER NAME =	DESIGNED - R.I. PETERS	REVISED -
	CHECKED - L.V. BORDEN	REVISED -
PLOT SCALE =	DRAWN - R.L. REED	REVISED -
PLOT DATE =	CHECKED - R.I. PETERS	REVISED -

**STATE OF ILLINOIS**  
**DEPARTMENT OF TRANSPORTATION**

**VARIOUS MOVABLE BRIDGES**  
**LOCAL CENTRALIZED CONTROL AND OPERATION**  
**BRANDON ROAD - FARSIDE MACHINERY ROOM LAYOUT**

SHEET NO. 7 OF 93 SHEETS

F.A.U. RTE.	SECTION	COUNTY	TOTAL SHEETS	SHEET NO.
0341	2011-045-I	WILL	466	332
CONTRACT NO. 60P55				

BRANDON, Drawing 06-007

ILLINOIS FED. AID PROJECT



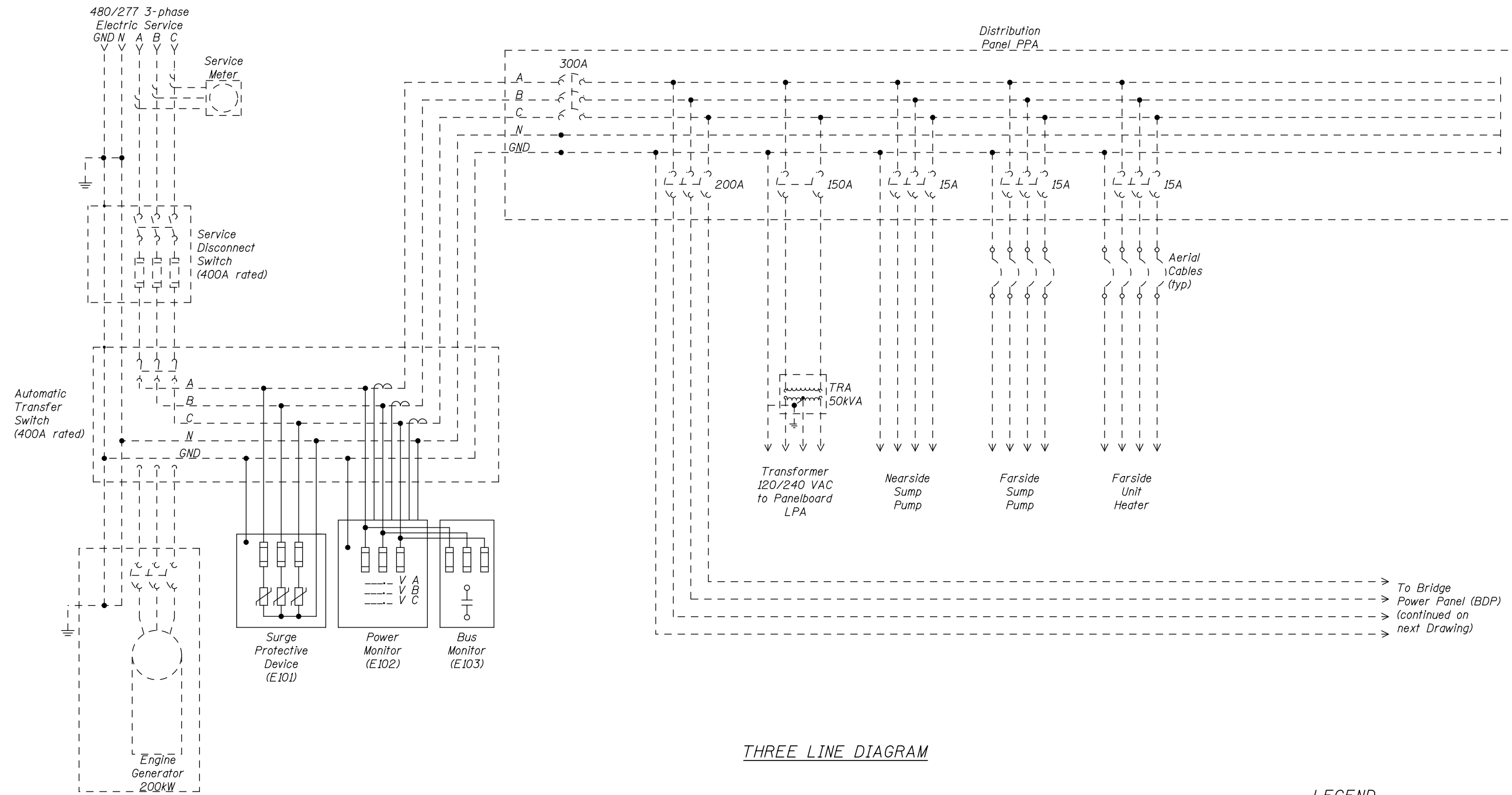

THREE LINE DIAGRAM

LEGEND

- - - - Existing Equipment, Wiring, and Conduit
- New Equipment, Wiring, and Conduit

NOTES:

1. The Contractor shall provide an appropriately sized Nema 12 electrical enclosure for the power monitor, bus monitor, and associated components.



USER NAME =	DESIGNED - R.I. PETERS	REVISED _____
	CHECKED - L.V. BORDEN	REVISED _____
PLOT SCALE =	DRAWN - R.I. PETERS	REVISED _____
PLOT DATE =	CHECKED - K.M. GABLE	REVISED _____

STATE OF ILLINOIS  
DEPARTMENT OF TRANSPORTATION

VARIOUS MOVABLE BRIDGES  
LOCAL CENTRALIZED CONTROL AND OPERATION  
BRANDON ROAD – THREE LINE DIAGRAM – 1

SHEET NO. 8 OF 93 SHEETS

F.A.U. RTE.	SECTION	COUNTY	TOTAL SHEETS	SHEET NO.
0341	2011-045-I	WILL	466	333
CONTRACT NO. 60P55				

ILLINOIS FED. AID PROJECT

BRANDON, Drawing 06-008

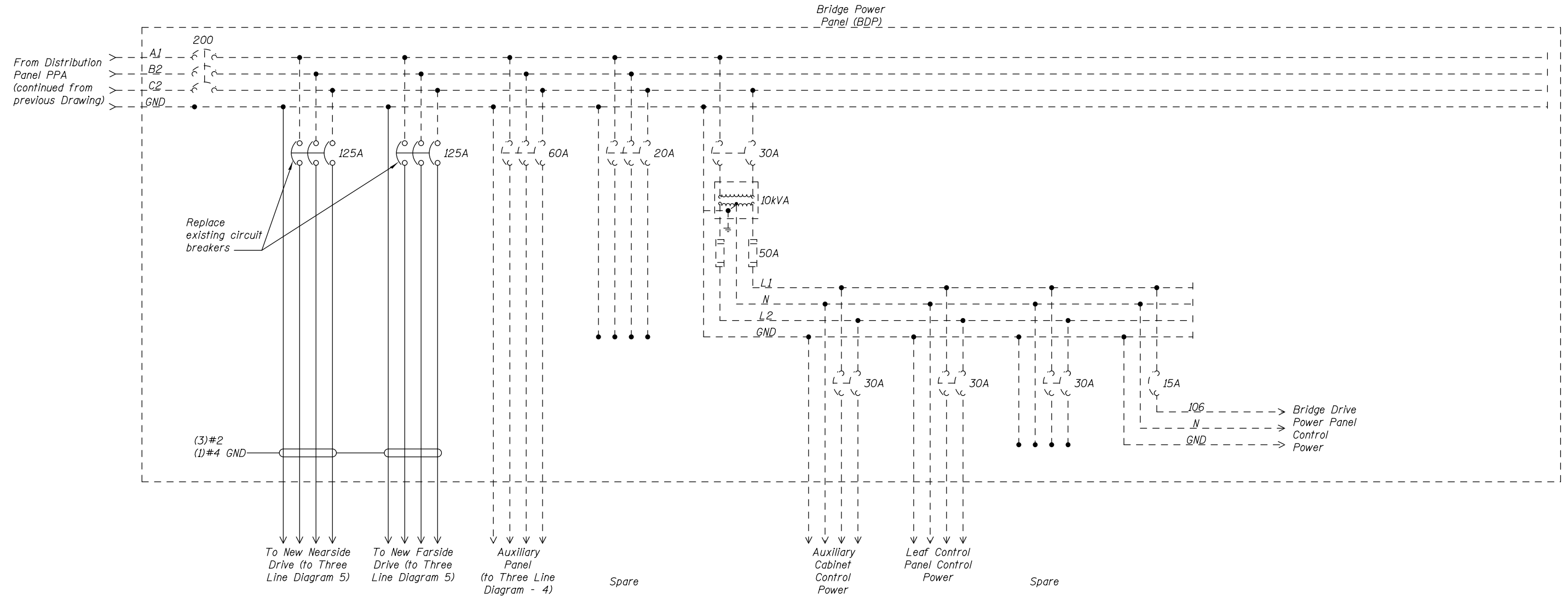

THREE LINE DIAGRAM

**LEGEND**  
 - - - - - Existing Equipment, Wiring, and Conduit  
 \_\_\_\_\_ New Equipment, Wiring, and Conduit

- NOTES:**
- Existing control power circuits shall be removed and replaced by circuits from panelboard LPA.
  - The Contractor shall be responsible for sizing all breakers, fuses, and conductors according to equipment and NEC requirements.



USER NAME =	DESIGNED - R.I. PETERS	REVISED _____
	CHECKED - L.V. BORDEN	REVISED _____
PLOT SCALE =	DRAWN - R.I. PETERS	REVISED _____
PLOT DATE =	CHECKED - K.M. GABLE	REVISED _____

STATE OF ILLINOIS  
 DEPARTMENT OF TRANSPORTATION

VARIOUS MOVABLE BRIDGES  
 LOCAL CENTRALIZED CONTROL AND OPERATION  
 BRANDON ROAD - THREE LINE DIAGRAM - 2

F.A.U. RTE.	SECTION	COUNTY	TOTAL SHEETS	SHEET NO.
0341	2011-045-I	WILL	466	334
CONTRACT NO. 60P55				

*This Sheet Intentionally Left Blank*



USER NAME =	DESIGNED - R.I. PETERS	REVISED	___
	CHECKED - L.V. BORDEN	REVISED	___
PLOT SCALE =	DRAWN - R.I. PETERS	REVISED	___
PLOT DATE =	CHECKED - K.M. GABLE	REVISED	___

**STATE OF ILLINOIS  
DEPARTMENT OF TRANSPORTATION**

**VARIOUS MOVABLE BRIDGES  
LOCAL CENTRALIZED CONTROL AND OPERATION  
BRANDON ROAD - THREE LINE DIAGRAM - 3**

SHEET NO. 10 OF 93 SHEETS

BRANDON, Drawing 06-010				
F.A.U. RTE.	SECTION	COUNTY	TOTAL SHEETS	SHEET NO.
0341	2011-045-I	WILL	466	335
			CONTRACT NO. 60P55	
ILLINOIS FED. AID PROJECT				

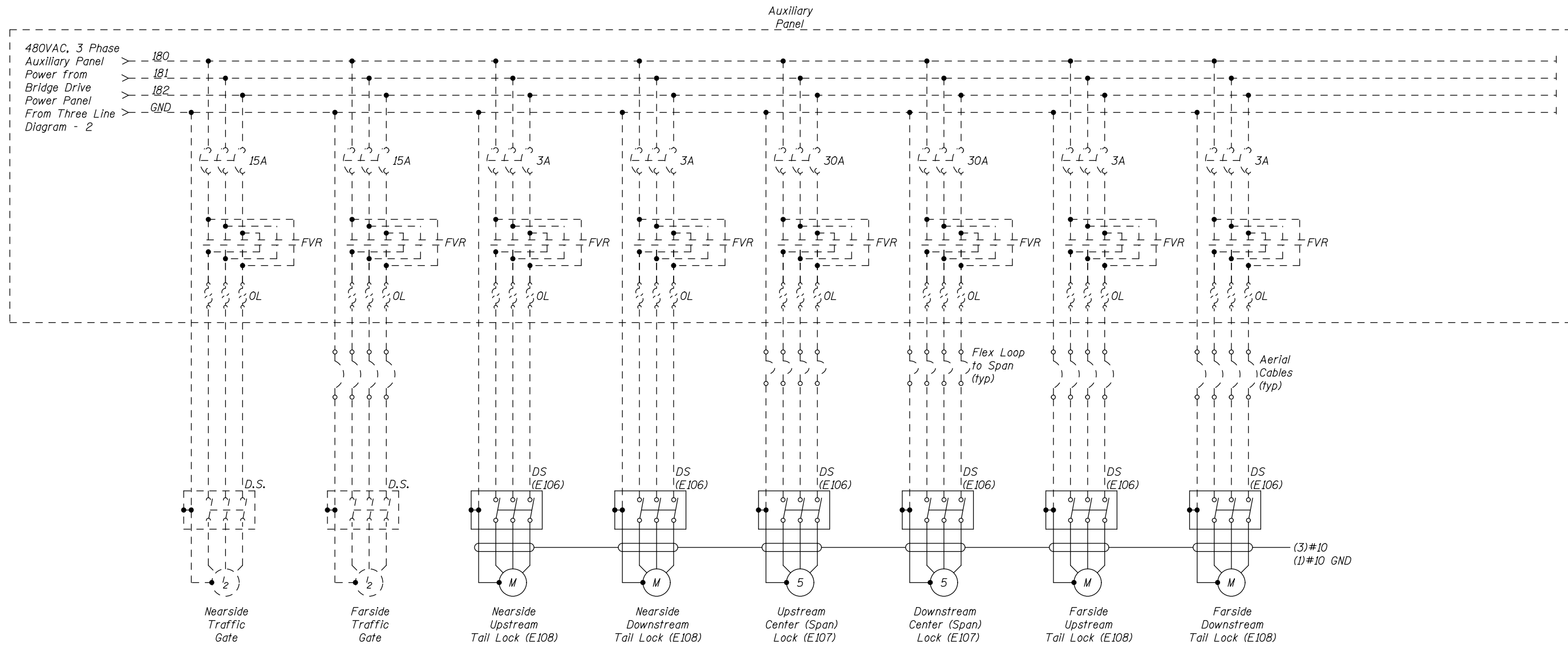

THREE LINE DIAGRAM - EXISTING EQUIPMENT

LEGEND

- Existing Equipment, Wiring, and Conduit
- New Equipment, Wiring, and Conduit
- ( # ) Motor with HP

NOTES:

1. Reuse existing Auxiliary panel, breakers, motor starters, and overload protection.
2. Remove all control components and wiring that will not be utilized with new control system.



USER NAME =	DESIGNED - R.I. PETERS	REVISED	---
	CHECKED - L.V. BORDEN	REVISED	---
PLOT SCALE =	DRAWN - R.I. PETERS	REVISED	---
PLOT DATE =	CHECKED - K.M. GABLE	REVISED	---

STATE OF ILLINOIS  
DEPARTMENT OF TRANSPORTATION

VARIOUS MOVABLE BRIDGES  
LOCAL CENTRALIZED CONTROL AND OPERATION  
BRANDON ROAD - THREE LINE DIAGRAM - 4

SHEET NO. 11 OF 93 SHEETS

F.A.U. RTE.	SECTION	COUNTY	TOTAL SHEETS	SHEET NO.
0341	2011-045-I	WILL	466	336
CONTRACT NO. 60P55				

ILLINOIS FED. AID PROJECT

BRANDON, Drawing 06-011

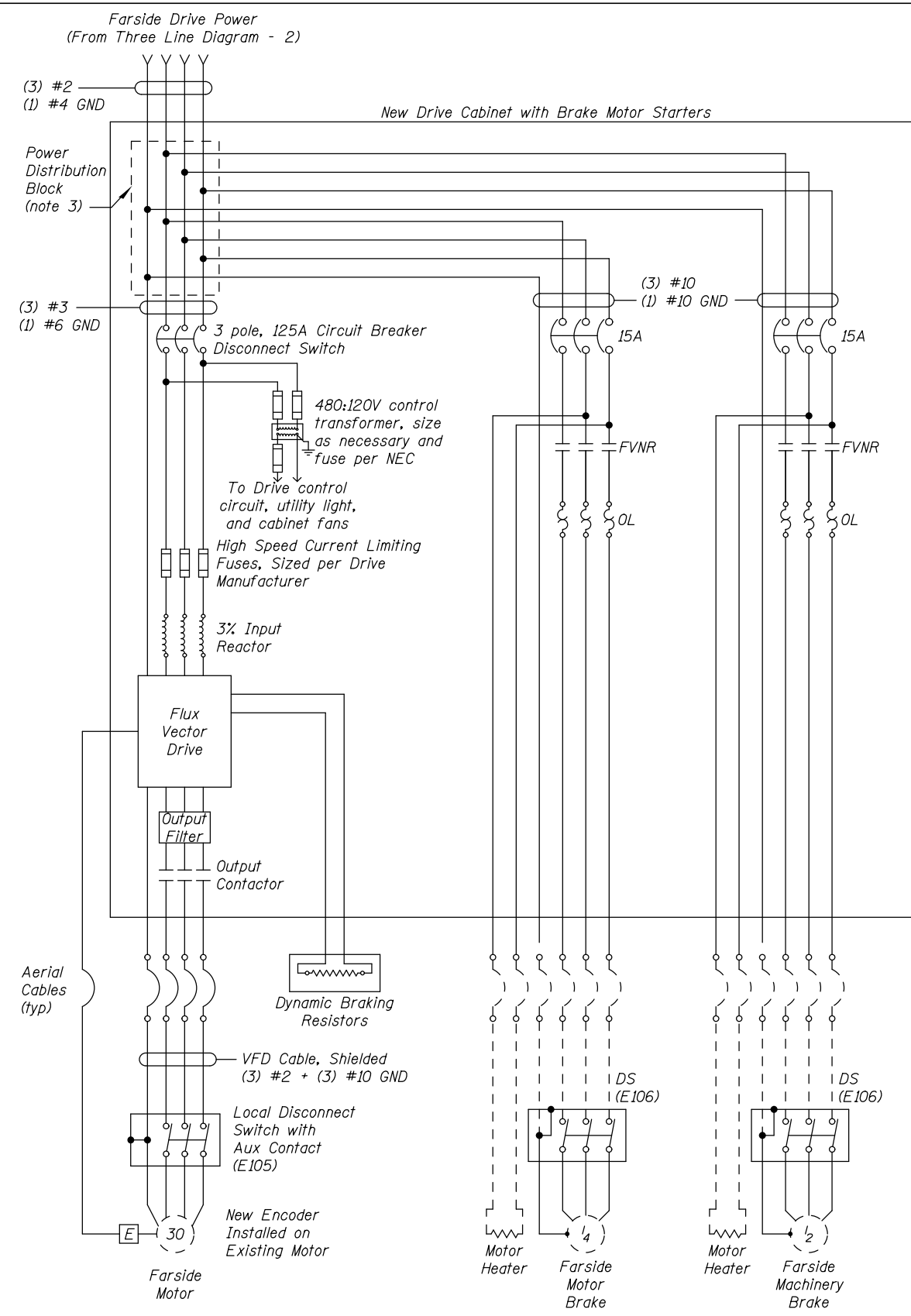
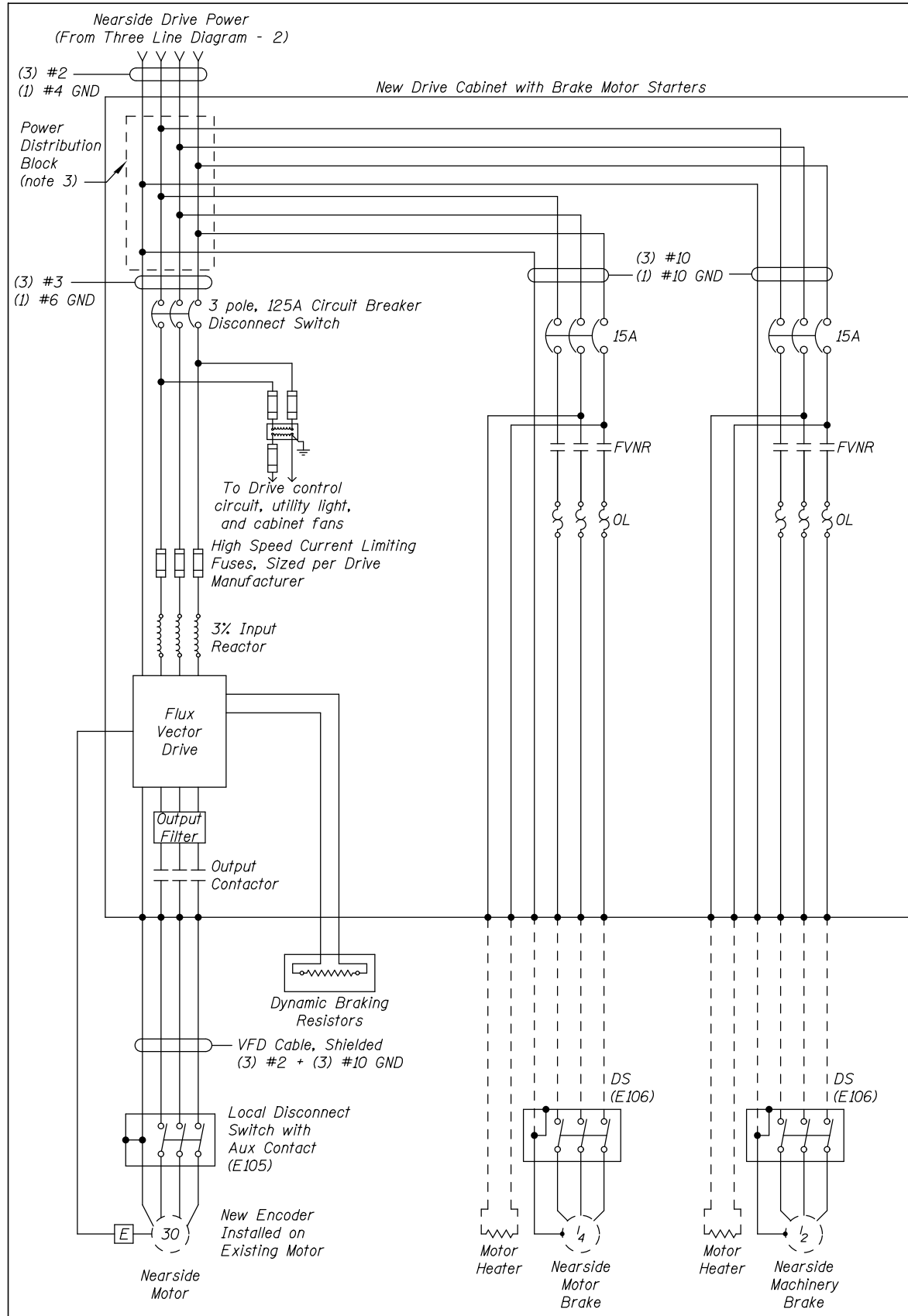

**NOTES:**

1. All enclosures, motors, and peripherals shall be grounded according to the NEC and drive manufacturer's recommendations.
2. Contractor is alerted to the fact that cabinets may need to be custom sized to fit available space in existing electrical rooms and to provide NEC working space around cabinets.
3. Provide power distribution blocks in drive cabinets to tap incoming feeder conductors.

**LEGEND**

- - - Existing Equipment, Wiring, and Conduit
- New Equipment, Wiring, and Conduit
- ( # ) Motor with HP



USER NAME =	DESIGNED - R.I. PETERS	REVISED -
	CHECKED - L.V. BORDEN	REVISED -
PLOT SCALE =	DRAWN - R.I. PETERS	REVISED -
PLOT DATE =	CHECKED - K.M. GABLE	REVISED -

**STATE OF ILLINOIS  
DEPARTMENT OF TRANSPORTATION**

**VARIOUS MOVABLE BRIDGES  
LOCAL CENTRALIZED CONTROL AND OPERATION  
BRANDON ROAD - THREE LINE DIAGRAM - 5**

BRANDON, Drawing 06-012				
F.A.U. RTE.	SECTION	COUNTY	TOTAL SHEETS	SHEET NO.
0341	2011-045-I	WILL	466	337
CONTRACT NO. 60P55				
ILLINOIS FED. AID PROJECT				

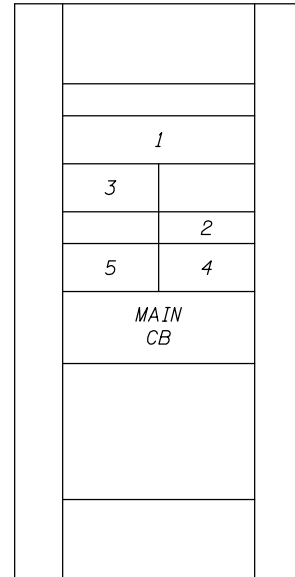

**ELEVATION**  
**EXISTING DISTRIBUTION PANEL PPA LAYOUT**  
 Scale: None

DISTRIBUTION PANEL PPA																																			
Voltage: 277/480V			Phase / Wire: 3 Ph / 4W			Manufacturer / Model: Westinghouse / PLR4B			Bus Amperes: 300			Main Circuit Breaker: Adj. Trip at 300A / 800A Frame			Short Circuit: 65,000 AIC at 480VAC			Location: Operator House Mezzanine Floor			Fed From: Bridge Service via Automatic Transfer Sw.			Mounting Enclosure: Surface / Nema 1											
Description	Load(Amps)			Breaker		A	B	C	Poles	Amps	1	2	3	4	5	Breaker			Load(Amps)			Description													
	A	B	C	Amps	Poles											A	B	C																	
Bridge Drive Power Panel	120	120	120	3	200											150	2	100	100	-	Transformer TRA / Panelboard LPA														
Farside Unit Heater	5	5	5	3	15											15	3	8	8	8	Farside Sump Pump														
Nearside Sump Pump	8	8	8	3	15																														
<div style="display: flex; align-items: center; justify-content: center;"> <table border="1" style="margin-right: 20px;"> <tr><th>A</th><th>B</th><th>C</th></tr> <tr><td>241</td><td>241</td><td>141</td></tr> </table> <table border="1" style="margin-left: 20px;"> <tr><th>A</th><th>B</th><th>C</th></tr> <tr><td>241</td><td>241</td><td>141</td></tr> </table> </div>												A	B	C	241	241	141	A	B	C	241	241	141	Total Connected Load = 241 Amps/Phase Demand Factor = 65% Demand Load = 157 Amps/Phase											
A	B	C																																	
241	241	141																																	
A	B	C																																	
241	241	141																																	

**EXISTING DISTRIBUTION PANEL PPA SCHEDULE**

**NOTES:**

- The Contractor shall field verify all DP loads served.

PANELBOARD LPA										
Voltage:		120/240V		Location:		Operator House Mezzanine Floor				
Phase / Wire:		1 Ph / 3W		Fed From:		Panel PPA via Transformer TRA				
Bus Amperes:		225A		Mounting Enclosure:		Surface / Nema 1				
Main Circuit Breaker:		225A		Manufacturer:		Westinghouse, Type PRL1				
Short Circuit:		10,000 AIC								
Description	Load(Amps)		Breaker		A	B	Breaker	Load(Amps)		Description
	A	B	Poles	Amps				Amps	Poles	
Nearside Receptacles	-	-	1	20	1	6	2	-	-	Electric Furnace
Nearside Receptacles	-	-	1	20	3	6	2	-	-	
Nearside Interior Lights	-	-	1	20	5	6	2	-	-	Air Conditioner Condensing Unit
Exterior Lights	-	-	1	20	7	6	2	-	-	
Marine Floodlights	-	-	1	15	9	6	2	-	-	Spare
Heat Trace	-	-	1	15	11	6	2	-	-	
Farside Interior Lights	-	-	1	20	13	6	2	-	-	Electric Toilet
Generator Battery Charger/Heat	-	-	1	40	15	6	2	-	-	
Generator Heater	-	-	1	20	17	6	2	-	-	Spare
CCTV	-	-	1	20	19	6	2	-	-	
CCTV Accessories	-	-	1	20	21	6	2	-	-	Panel SBP - Note 2 (Standby Power to Automatic Transf. Sw.)
Farside Receptacles	-	-	1	20	23	6	2	-	-	
Water Heater	-	-	2	20	25	6	1	-	-	Spare
Spare	-	-	1	20	27	6	1	-	-	Spare
Spare	-	-	1	15	29	6	1	-	-	Spare
					31	6	1	-	-	Spare
					33					
					35					

EXISTING PANELBOARD LPA SCHEDULE

PANELBOARD LPA										
Voltage:		120/240V		Location:		Operator House Mezzanine Floor				
Phase / Wire:		1 Ph / 3W		Fed From:		Panel PPA via Transformer TRA				
Bus Amperes:		225A		Mounting Enclosure:		Surface / Nema 1				
Main Circuit Breaker:		225A		Manufacturer:		Westinghouse, Type PRL1				
Short Circuit:		10,000 AIC								
Description	Load(Amps)		Breaker		A	B	Breaker	Load(Amps)		Description
	A	B	Poles	Amps				Amps	Poles	
Nearside Receptacles	6	-	1	20	1	6	2	80	80	Electric Furnace
Nearside Receptacles	-	6	1	20	3	6	2	-	-	
Nearside Interior Lights	8	-	1	20	5	6	2	-	-	Air Conditioner Condensing Unit
Exterior Lights	-	10	1	20	7	6	2	-	-	
Marine Floodlights	10	-	1	15	9	6	1	8	-	Nearside CCTV Cameras
Heat Trace	-	4	1	15	11	6	1	-	8	Farside CCTV Cameras
Farside Interior Lights	4	-	1	20	13	6	2	16	16	Electric Toilet
Generator Battery Charger/Heat	-	25	1	40	15	6	2	-	-	
Generator Heater	5	-	1	20	17	6	1	8	-	N.S. Traffic & Gate Lights,Gongs
CCTV System / Rack	-	8	1	20	19	6	1	-	8	F.S. Traffic & Gate Lights,Gongs
Network UPS / Rack	8	-	1	20	21	6	2	4	7	Panel SBP - (Standby Power to Automatic Transf. Sw.)
Farside Receptacles	-	6	1	20	23	6	1	7	-	Pier and Span Navigation Lights
Water Heater	10	10	2	20	25	6	1	1	-	Boat Detection
PLC Controls	12	-	1	20	27	6	1	8	-	Public Address System
PLC Panel Auxiliary	-	5	1	15	31	6	1	-	-	Spare
Farside Remote I/O	5	-	1	20	33	6	1	-	-	Spare
Farside Network Equipment	-	6	1	20	35	6	1	-	-	Spare

A	B
199	200

Total Connected Load = 200 Amps/Phase  
Demand Factor = 65%  
Demand Load = 130 Amps/Phase

PROPOSED PANELBOARD LPA SCHEDULE (EXISTING PANELBOARD WITH NEW CIRCUITS)

PANELBOARD SBP										
Voltage:		120/240V		Location:		Operator House Ground Floor Electrical				
Phase / Wire:		1 Ph / 3W		Fed From:		Panelboard LPA (Note 2)				
Bus Amperes:		100A		Mounting Enclosure:		Surface / Nema 1				
Main Circuit Breaker:		N/A		Manufacturer:		Westinghouse, Type PRL1				
Short Circuit:		10,000 AIC								
Description	Load(Amps)		Breaker		A	B	Breaker	Load(Amps)		Description
	A	B	Poles	Amps				Amps	Poles	
Interior Lights	-	-	1	20	1	6	2	-	-	(Aux Panel Standby Power)
Receptacles near Radio	-	-	1	20	3	6	1	-	-	
Spare	-	-	1	20	5	6	1	-	-	Spare
Marine Siren	-	-	1	15	7	6	1	-	-	Spare
					9					
					11					

EXISTING PANELBOARD SBP SCHEDULE

PANELBOARD SBP										
Voltage:		120/240V		Location:		Operator House Ground Floor Electrical				
Phase / Wire:		1 Ph / 3W		Fed From:		Panelboard LPA (Note 2)				
Bus Amperes:		100A		Mounting Enclosure:		Surface / Nema 1				
Main Circuit Breaker:		N/A		Manufacturer:		Westinghouse, Type PRL1				
Short Circuit:		10,000 AIC								
Description	Load(Amps)		Breaker		A	B	Breaker	Load(Amps)		Description
	A	B	Poles	Amps				Amps	Poles	
Interior Lights	4	-	1	20	1	6	2	-	-	(Aux Panel Standby Power)
Receptacles near Radio	-	6	1	20	3	6	1	-	-	
Fire/Security System	2	-	1	20	5	6	1	-	-	Spare
Signal Horn	-	1	1	15	7	6	1	-	-	Spare
					9					
					11					

A	B
6	7

Total Connected Load = 7 Amps/Phase  
Demand Factor = 65%  
Demand Load = 5 Amps/Phase

PROPOSED PANELBOARD SBP SCHEDULE (EXISTING PANELBOARD WITH REUSED CIRCUITS)

NOTES:

- The Contractor shall field verify all existing circuits before starting work.
- The Contractor shall field verify the source of power for panelboard SBP.
- Rearrange circuits and provide new breakers as shown in panelboard LPA.
- The Contractor shall provide a neat typewritten or computer printed circuit legend with circuit descriptions for each panelboard.
- Circuits shall be arranged as required to balance loading.
- Power for PLC and Remote I/O racks shall utilize the same (A or B) phase where fed from the same power source.



USER NAME =	DESIGNED - R.I. PETERS	REVISED -
	CHECKED - L.V. BORDEN	REVISED -
PLOT SCALE =	DRAWN - R.I. PETERS	REVISED -
PLOT DATE =	CHECKED - K.M. GABLE	REVISED -

STATE OF ILLINOIS  
DEPARTMENT OF TRANSPORTATION

VARIOUS MOVABLE BRIDGES  
LOCAL CENTRALIZED CONTROL AND OPERATION  
BRANDON ROAD - PANELBOARD SCHEDULES

SHEET NO. 14 OF 93 SHEETS

BRANDON, Drawing 06-014				
F.A.U. RTE.	SECTION	COUNTY	TOTAL SHEETS	SHEET NO.
0341	2011-045-I	WILL	466	339
CONTRACT NO. 60P55				
ILLINOIS FED. AID PROJECT				

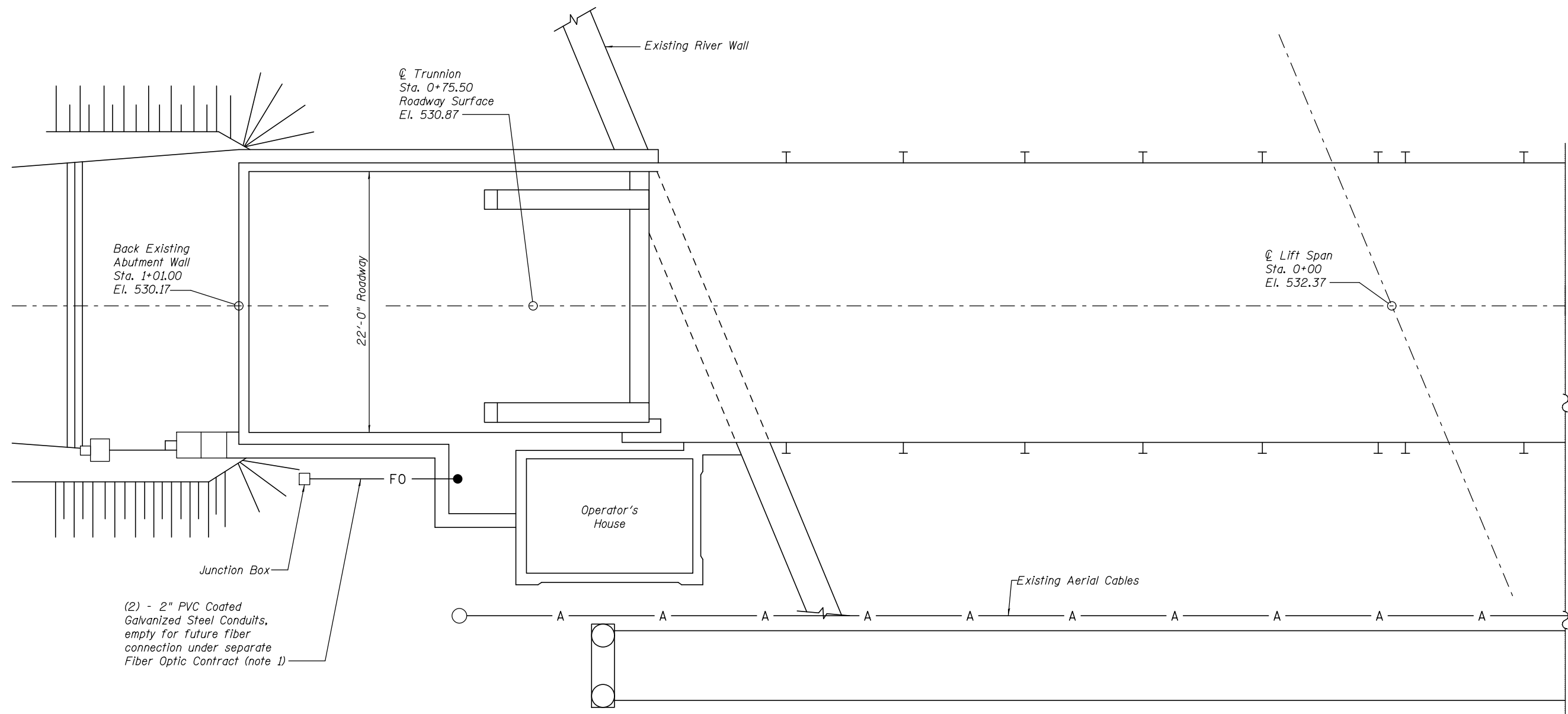
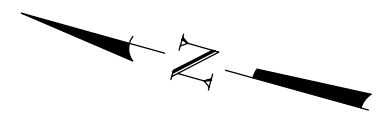

PLAN

**NOTES:**

1. Refer to drawings 06-083 through 06-085 for Bridge Conduit Diagrams and 06-086 through 06-088 for Bridge Conduit Tabulations.
2. The Contractor shall not cut, drill, or weld Bridge Structural Members without approval by the Engineer.
3. Provide conduit expansion/deflection fittings at all structural expansion joints and at locations subject to structural movement.
4. Refer to drawing 02-095 for typical details on mounting conduits to structure.

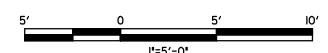

BRANDON, Drawing 06-015



USER NAME =	DESIGNED - R.I. PETERS	REVISED	___
	CHECKED - L.V. BORDEN	REVISED	___
PLOT SCALE =	DRAWN - R.I. PETERS	REVISED	___
PLOT DATE =	CHECKED - K.M. GABLE	REVISED	___

**STATE OF ILLINOIS  
DEPARTMENT OF TRANSPORTATION**

**VARIOUS MOVABLE BRIDGES  
LOCAL CENTRALIZED CONTROL AND OPERATION  
BRANDON ROAD – FIBER OPTIC ROUTE TO OPERATOR HOUSE**

F.A.U. RTE.	SECTION	COUNTY	TOTAL SHEETS	SHEET NO.
0341	2011-045-I	WILL	466	340
CONTRACT NO. 60P55				

SHEET NO. 15 OF 93 SHEETS

ILLINOIS FED. AID PROJECT



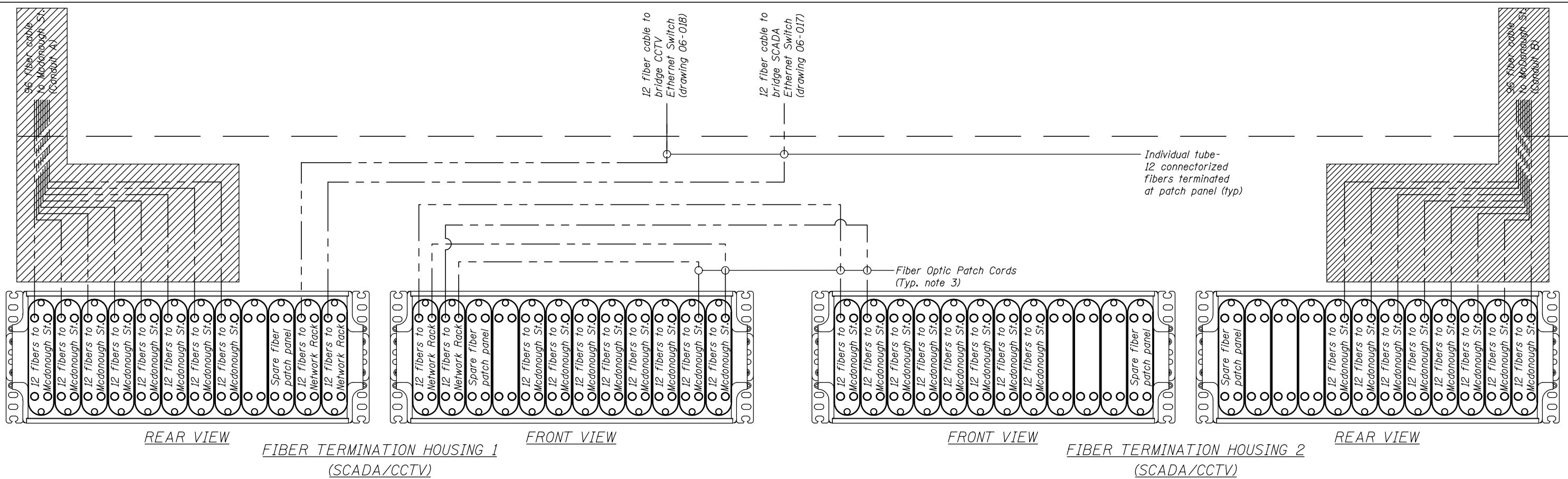

Fiber Optic Interconnect Cabinet

**LEGEND**

- Fiber optic connection
- Denotes to be installed under future separate Fiber Optic Contract

**NOTES:**

1. Refer to sheet nos. 12 and 13 for fiber optic interconnections with other bridges.
2. All fiber optic cable shown is singlemode type.
3. Provide patch cables to interconnect all 96 fibers of main network cables between locations.



USER NAME =	DESIGNED - R.I. PETERS	REVISED	---
	CHECKED - L.V. BORDEN	REVISED	---
PLOT SCALE =	DRAWN - R.I. PETERS	REVISED	---
PLOT DATE =	CHECKED - K.M. GABLE	REVISED	---

**STATE OF ILLINOIS  
DEPARTMENT OF TRANSPORTATION**

**VARIOUS MOVABLE BRIDGES  
LOCAL CENTRALIZED CONTROL AND OPERATION  
BRANDON ROAD - FIBER OPTIC INTERCONNECT CABINET**

SHEET NO. 16 OF 93 SHEETS

F.A.U. RTE.		SECTION	COUNTY	TOTAL SHEETS	SHEET NO.
0341		2011-045-I	WILL	466	341
					CONTRACT NO. 60P55

BRANDON, Drawing 06-016

ILLINOIS FED. AID PROJECT

To Brandon Rd. bridge control system Ethernet switch drawing 06-028

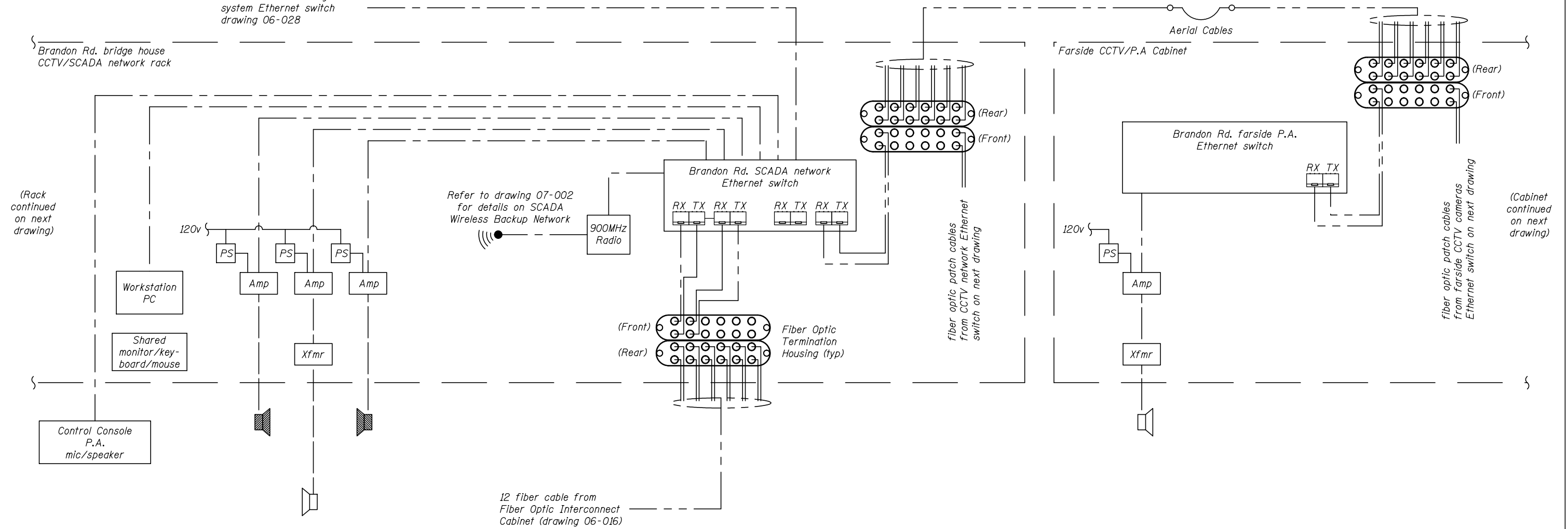

(Rack continued on next drawing)

(Cabinet continued on next drawing)

**LEGEND**

- Speaker wire connection
- Fiber optic connection
- · - · - · - Cat6 ethernet connection
- Power connection
- Video / Comm connection
- ▣ Two-way speaker      ▢ One-way speaker
- (((•)) Wireless network antenna

PUBLIC ADDRESS SYSTEMS EQUIPMENT		
Item No.	Quantity	Item Description
1	1	Rack mount workstation computer
2	1	Monitor, pointer, and keyboard for computer
3	1	Console microphone/speaker and accessories
4	4	Amplifier power supply
5	4	Network speaker amplifier
6	2	One-way speaker transformer
7	2	Two-way outdoor speaker
8	2	One-way outdoor speaker
9	4	Speaker surge protection
10	as req.	Circuit breaker
11	2	Surge Protective Device
12	1	24VDC power supply
13	1	Industrial Ethernet switch
14	1	Utility receptacle
15	as req.	Accessories and installation hardware

WIRELESS BACKUP NETWORK EQUIPMENT		
Item No.	Quantity	Item Description
1*	3	900 MHz Ethernet radio
2*	3	900 MHz antenna with installation hardware & accessories
3	3	Antenna surge suppressor
4	3	Surge Protective Device
5	3	Circuit breaker
6	3	24VDC power supply/UPS
7	as req.	Accessories and installation hardware

\* 2 Radio and 2 antenna for CCTV wireless system, shown on drawing 06-017

SCADA SYSTEM EQUIPMENT		
Item No.	Quantity	Item Description
1	1	CCTV/SCADA network rack
2	1	Rack mounted UPS (Uninterruptible Power Supply)
3	1	SCADA network Ethernet switch
4	4	Rack mount fiber termination housings, 12 position
5	as req.	Rack accessories and hardware

**NOTES:**

1. These equipment schedules are provided for reference and do not provide an exhaustive listing of all equipment required.
2. The Contractor shall be responsible for developing a complete bill of materials of equipment required.



USER NAME =	DESIGNED - R.I. PETERS	REVISED -
	CHECKED - L.V. BORDEN	REVISED -
PLOT SCALE =	DRAWN - R.I. PETERS	REVISED -
PLOT DATE =	CHECKED - K.M. GABLE	REVISED -

STATE OF ILLINOIS  
DEPARTMENT OF TRANSPORTATION

VARIOUS MOVABLE BRIDGES  
LOCAL CENTRALIZED CONTROL AND OPERATION  
BRANDON ROAD - SCADA ONE-LINE

SHEET NO. 17 OF 93 SHEETS

F.A.U. RTE.		SECTION	COUNTY	TOTAL SHEETS	SHEET NO.
0341		2011-045-1	WILL	466	342
CONTRACT NO. 60P55					

ILLINOIS FED. AID PROJECT

BRANDON, Drawing 06-017

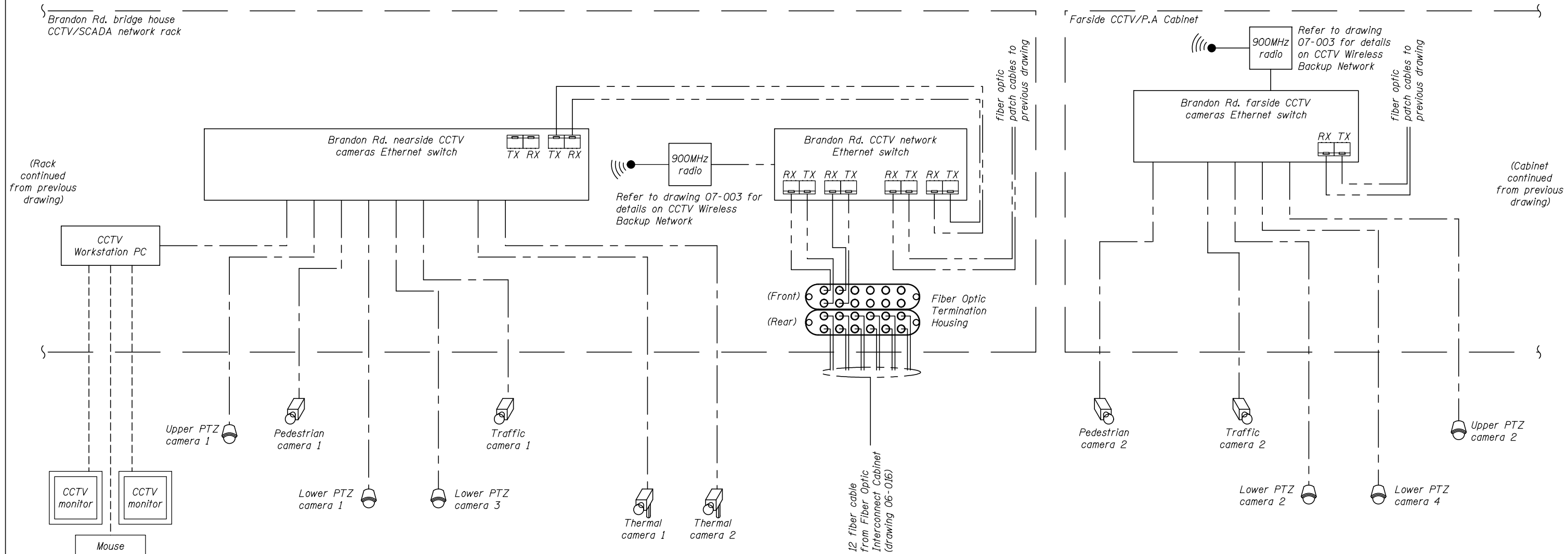

**LEGEND**

- Fiber optic connection
- Cat6 connection
- Power connection
- Video / Comm connection

- Pan-tilt-zoom (PTZ) camera
- Pan-tilt thermal camera
- Fixed camera
- Wireless Network Antenna

BRIDGE CONTROL CCTV SYSTEM EQUIPMENT		
Item No.	Quantity	Item Description
1	1	Rack mounted UPS (Uninterruptible Power Supply)
2	1	CCTV network Ethernet switch
3	1	Nearside CCTV camera Ethernet switch
4	4	Rack mount fiber termination housings, 12 position
5	1	CCTV workstation PC
6	1	Mouse / pointer
7	2	31.5" 1080p video monitor
8	6	Pan-Tilt-Zoom CCTV camera with lens, enclosure, and accessories
9	2	Pan-Tilt Thermal CCTV camera with lens, enclosure, accessories
10	4	Fixed CCTV camera with lens, enclosure, accessories
11	12	CCTV ethernet surge protection
12	as req.	Camera power supplies
13	as req.	Camera circuit breakers
14	as req.	POE (Power Over Ethernet) converters

BRIDGE CONTROL CCTV SYSTEM EQUIPMENT (continued)		
Item No.	Quantity	Item Description
15	1	Farside Cabinet for CCTV and public address equipment with equipment & accessories
16	2	Surge Protective Device
17	1	Industrial cabinet UPS
18	1	24VDC power supply
19	1	Industrial Ethernet switch
20	1	Cabinet mount fiber termination housing, 12 position

**NOTES:**

- These equipment schedules are provided for reference and do not provide an exhaustive listing of all equipment required.
- The Contractor shall be responsible for developing a complete bill of materials of equipment required.



USER NAME =	DESIGNED - R.I. PETERS	REVISED -
	CHECKED - L.V. BORDEN	REVISED -
PLOT SCALE =	DRAWN - R.I. PETERS	REVISED -
PLOT DATE =	CHECKED - K.M. GABLE	REVISED -

**STATE OF ILLINOIS  
DEPARTMENT OF TRANSPORTATION**

**VARIOUS MOVABLE BRIDGES  
LOCAL CENTRALIZED CONTROL AND OPERATION  
BRANDON ROAD - CCTV ONE-LINE**

BRANDON, Drawing 06-018			
F.A.U. R.T.E.	SECTION	COUNTY	TOTAL SHEETS SHEET NO.
0341	2011-045-I	WILL	466 343
CONTRACT NO. 60P55			
ILLINOIS FED. AID PROJECT			



<i>Brandon Rd. pedestrian camera 1</i>	
Camera type	Fixed pedestrian
Focal length (mm.)*	4.4-132mm (30x zoom)
Camera height (ft.)	43 ft
Camera tilt (°)	-7°

<i>Brandon Rd. pedestrian camera 2</i>	
Camera type	Fixed pedestrian
Focal length (mm.)*	4.4-132mm (30x zoom)
Camera height (ft.)	43 ft
Camera tilt (°)	-7°



Camera height is based off of pool elevation (EL. +539.91). Location and camera height are approximate. See 'CCTV Plan and Elevation' drawings for mounting details. Camera positioning to be field adjusted at each location.

\*Zoom lens focal length shall be field adjusted to the desired field of view.



USER NAME =	DESIGNED - K.M. GABLE	REVISED	---
	CHECKED - L.V. BORDEN	REVISED	---
PLOT SCALE =	DRAWN - R.L. REED	REVISED	---
PLOT DATE =	CHECKED - R.I. PETERS	REVISED	---

STATE OF ILLINOIS  
DEPARTMENT OF TRANSPORTATION

VARIOUS MOVABLE BRIDGES  
LOCAL CENTRALIZED CONTROL AND OPERATION  
BRANDON ROAD - PEDESTRIAN CAMERA LAYOUT

SHEET NO. 19 OF 93 SHEETS

F.A.U. RTE.	SECTION	COUNTY	TOTAL SHEETS	SHEET NO.
0341	2011-045-I	WILL	466	344
				CONTRACT NO. 60P55
ILLINOIS FED. AID PROJECT				

BRANDON, Drawing 06-019



BRANDON RD. TRAFFIC CAMERA 1	
Camera type	Fixed traffic
Focal length (mm.)*	4.4-132mm (30x zoom)
Camera height (ft.)	70 ft
Camera tilt (°)	-50°

BRANDON RD. TRAFFIC CAMERA 2	
Camera type	Fixed traffic
Focal length (mm.)*	4.4-132mm (30x zoom)
Camera height (ft.)	70 ft
Camera tilt (°)	-50°

Camera height is based off of pool elevation (EL. +539.91). Location and camera height are approximate. See 'CCTV Plan and Elevation' drawings for mounting details. Camera positioning to be field adjusted at each location.

\*Zoom lens focal length shall be field adjusted to the desired field of view.



USER NAME =	DESIGNED - K.M. GABLE	REVISED	___
	CHECKED - L.V. BORDEN	REVISED	___
PLOT SCALE =	DRAWN - R.L. REED	REVISED	___
PLOT DATE =	CHECKED - R.I. PETERS	REVISED	___

STATE OF ILLINOIS  
DEPARTMENT OF TRANSPORTATION

VARIOUS MOVABLE BRIDGES  
LOCAL CENTRALIZED CONTROL AND OPERATION  
BRANDON ROAD - TRAFFIC CAMERA LAYOUT

SHEET NO. 20 OF 93 SHEETS

BRANDON, Drawing 06-020				
F.A.U. RTE.	SECTION	COUNTY	TOTAL SHEETS	SHEET NO.
0341	2011-045-I	WILL	466	345
			CONTRACT NO. 60P55	
ILLINOIS FED. AID PROJECT				



BRANDON RD. UPPER PTZ CAMERA 1	
Camera type	Upper PTZ
Focal length (mm.)	4.4-132mm (30x zoom)
Camera height (ft.)	70 ft
Camera tilt (°)	-90° to 5°

BRANDON RD. UPPER PTZ CAMERA 2	
Camera type	Upper PTZ
Focal length (mm.)	4.4-132mm (30x zoom)
Camera height (ft.)	70 ft
Camera tilt (°)	-90° to 5°

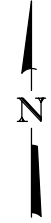

- NOTES:**
1. Camera field of view shown for illustration purposes and is adjustable as required.
  2. Camera height is based off of pool elevation (EL. +539.91). Location and camera height are approximate. See 'CCTV Plan and Elevation' drawings for mounting details. Camera positioning to be field adjusted at each location.



USER NAME =	DESIGNED - K.M. GABLE	REVISED	___
	CHECKED - L.V. BORDEN	REVISED	___
PLOT SCALE =	DRAWN - R.L. REED	REVISED	___
PLOT DATE =	CHECKED - R.I. PETERS	REVISED	___

**STATE OF ILLINOIS  
DEPARTMENT OF TRANSPORTATION**

**VARIOUS MOVABLE BRIDGES  
LOCAL CENTRALIZED CONTROL AND OPERATION  
BRANDON ROAD - UPPER PTZ CAMERA LAYOUT**

SHEET NO. 21 OF 93 SHEETS

F.A.U. RTE.	SECTION	COUNTY	TOTAL SHEETS	SHEET NO.
0341	2011-045-I	WILL	466	346
CONTRACT NO. 60P55				
ILLINOIS FED. AID PROJECT				

BRANDON, Drawing 06-021



BRANDON RD. THERMAL CAMERA 1	
Camera type	Lower thermal (pan & tilt)
Focal length (mm.)	35 mm
Camera height (ft.)	15 ft
Camera tilt (°)	0°

BRANDON RD. THERMAL CAMERA 2	
Camera type	Lower thermal (pan & tilt)
Focal length (mm.)	35 mm
Camera height (ft.)	15 ft
Camera tilt (°)	0°

Camera height is based off of pool elevation (EL. +539.91). Location and camera height are approximate. See 'CCTV Plan and Elevation' drawings for mounting details. Camera positioning to be field adjusted at each location.

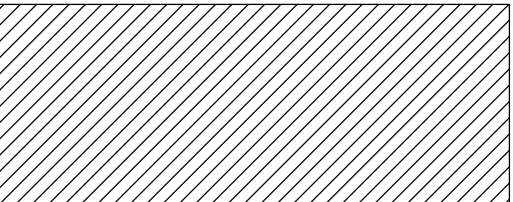

Human Identification\*  
(26 vertical Pixels on Target)

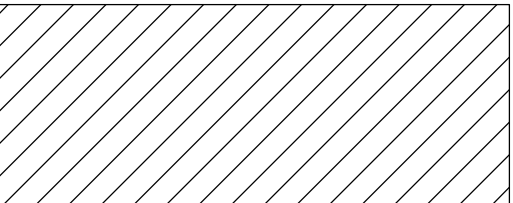

Human Recognition\*  
(8 vertical Pixels on Target)

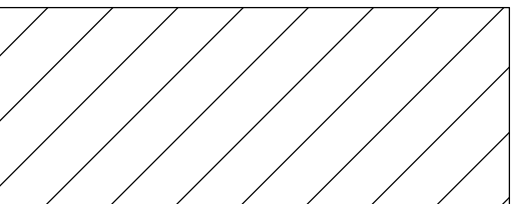

Human Detection\*  
(2 vertical Pixels on Target)

\*Viewing distance criteria based on image resolution of 640x480 (VGA format)



USER NAME =	DESIGNED - K.M. GABLE	REVISED	___
	CHECKED - L.V. BORDEN	REVISED	___
PLOT SCALE =	DRAWN - R.L. REED	REVISED	___
PLOT DATE =	CHECKED - R.I. PETERS	REVISED	___

STATE OF ILLINOIS  
DEPARTMENT OF TRANSPORTATION

VARIOUS MOVABLE BRIDGES  
LOCAL CENTRALIZED CONTROL AND OPERATION  
BRANDON ROAD - THERMAL CAMERA LAYOUT

SHEET NO. 22 OF 93 SHEETS

F.A.U. RTE.	SECTION	COUNTY	TOTAL SHEETS	SHEET NO.
0341	2011-045-I	WILL	466	347
CONTRACT NO. 60P55				
ILLINOIS FED. AID PROJECT				

BRANDON, Drawing 06-022

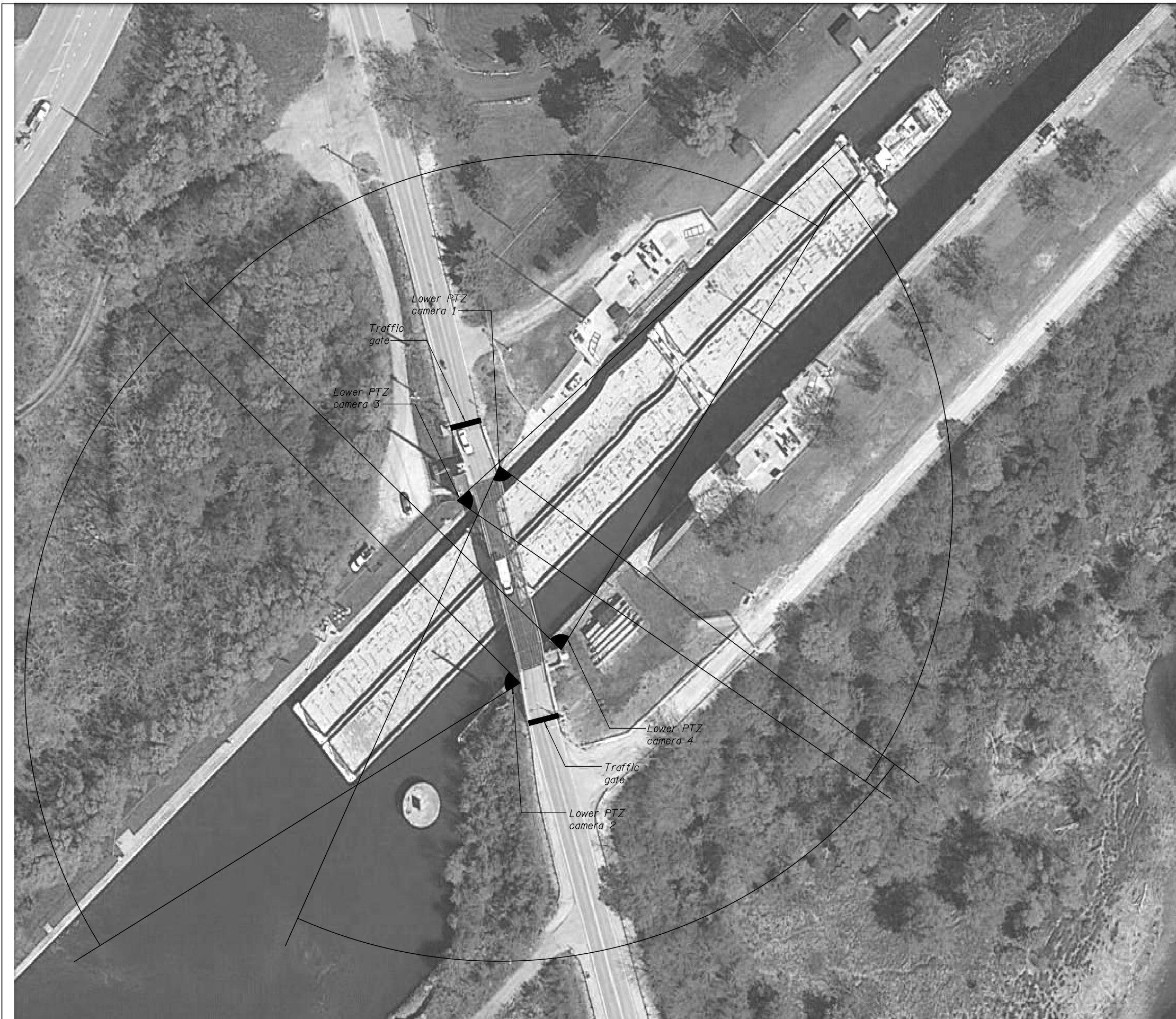

BRANDON RD. LOWER PTZ CAMERA 1	
Camera type	Lower PTZ
Focal length (mm.)	4.4-132mm (30x zoom)
Camera height (ft.)	15 ft
Camera tilt (°)	0° (at rest)

BRANDON RD. LOWER PTZ CAMERA 2	
Camera type	Lower PTZ
Focal length (mm.)	4.4-132mm (30x zoom)
Camera height (ft.)	15 ft
Camera tilt (°)	0° (at rest)

BRANDON RD. LOWER PTZ CAMERA 3	
Camera type	Lower PTZ
Focal length (mm.)	4.4-132mm (30x zoom)
Camera height (ft.)	15 ft
Camera tilt (°)	0° (at rest)

BRANDON RD. LOWER PTZ CAMERA 4	
Camera type	Lower PTZ
Focal length (mm.)	4.4-132mm (30x zoom)
Camera height (ft.)	15 ft
Camera tilt (°)	0° (at rest)

- NOTES:**
1. Camera field of view shown for illustration purposes and is adjustable as required.
  2. Camera height is based off of pool elevation (EL. +539.91). Location and camera height are approximate. See 'CCTV Plan and Elevation' drawings for mounting details. Camera positioning to be field adjusted at each location.



USER NAME =	DESIGNED - K.M. GABLE	REVISED	___
	CHECKED - L.V. BORDEN	REVISED	___
PLOT SCALE =	DRAWN - R.L. REED	REVISED	___
PLOT DATE =	CHECKED - R.I. PETERS	REVISED	___

STATE OF ILLINOIS  
DEPARTMENT OF TRANSPORTATION

VARIOUS MOVABLE BRIDGES  
LOCAL CENTRALIZED CONTROL AND OPERATION  
BRANDON ROAD - LOWER PTZ CAMERA LAYOUT  
SHEET NO. 23 OF 93 SHEETS

F.A.U. RTE.	SECTION	COUNTY	TOTAL SHEETS	SHEET NO.
0341	2011-045-I	WILL	466	348
CONTRACT NO. 60P55				
ILLINOIS FED. AID PROJECT				

BRANDON, Drawing 06-023



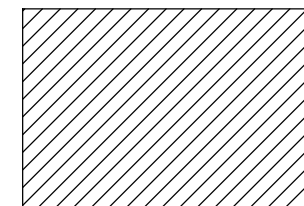
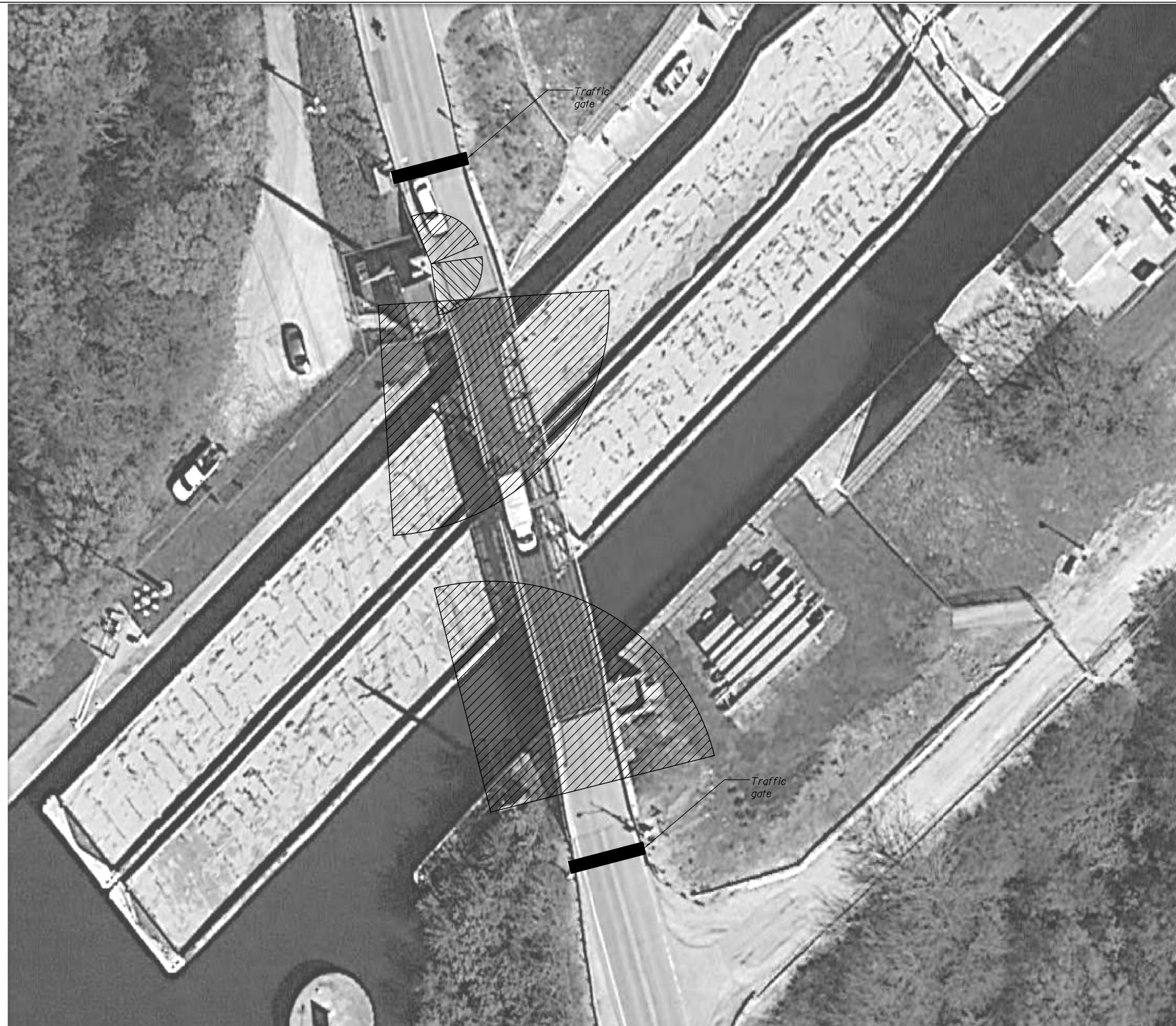

90db audible  
1-way speaker

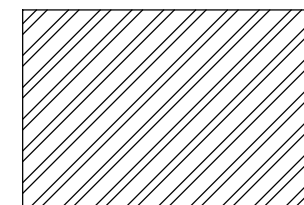

2-way microphone range  
2-way speaker



USER NAME =	DESIGNED - K.M. GABLE	REVISED	---
	CHECKED - L.V. BORDEN	REVISED	---
PLOT SCALE =	DRAWN - R.L. REED	REVISED	---
PLOT DATE =	CHECKED - R.I. PETERS	REVISED	---

STATE OF ILLINOIS  
DEPARTMENT OF TRANSPORTATION

VARIOUS MOVABLE BRIDGES  
LOCAL CENTRALIZED CONTROL AND OPERATION  
BRANDON ROAD - P.A. SPEAKER LAYOUT

SHEET NO. 24 OF 93 SHEETS

BRANDON, Drawing 06-024			
F.A.U. RTE.	SECTION	COUNTY	TOTAL SHEETS
0341	2011-045-I	WILL	466
			SHEET NO. 349
CONTRACT NO. 60P55			
ILLINOIS FED. AID PROJECT			

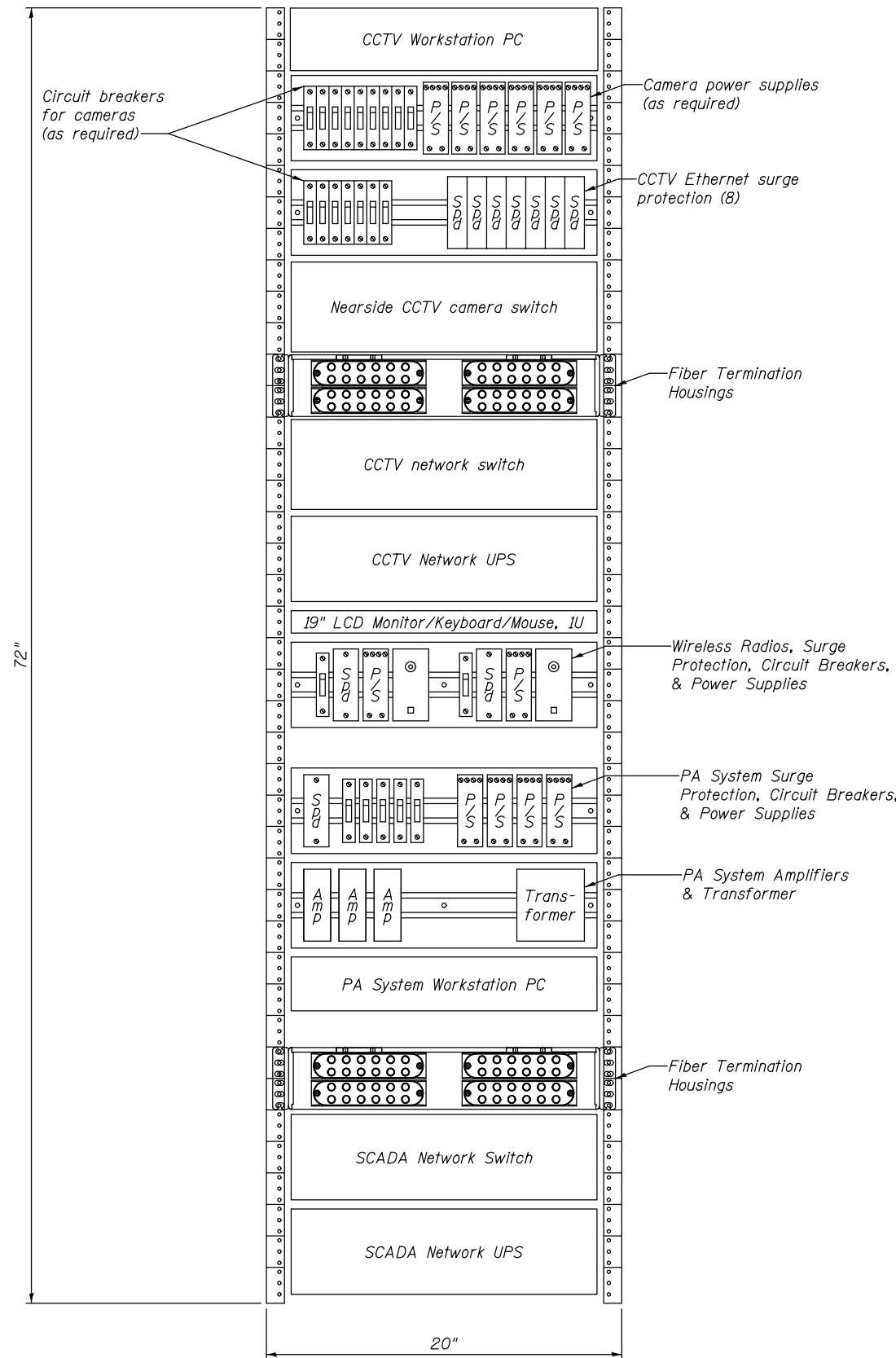

CCTV/SCADA NETWORK RACK

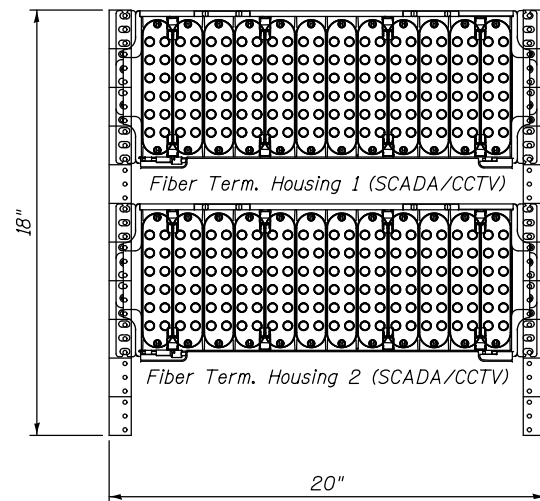

FIBER OPTIC INTERCONNECT CABINET

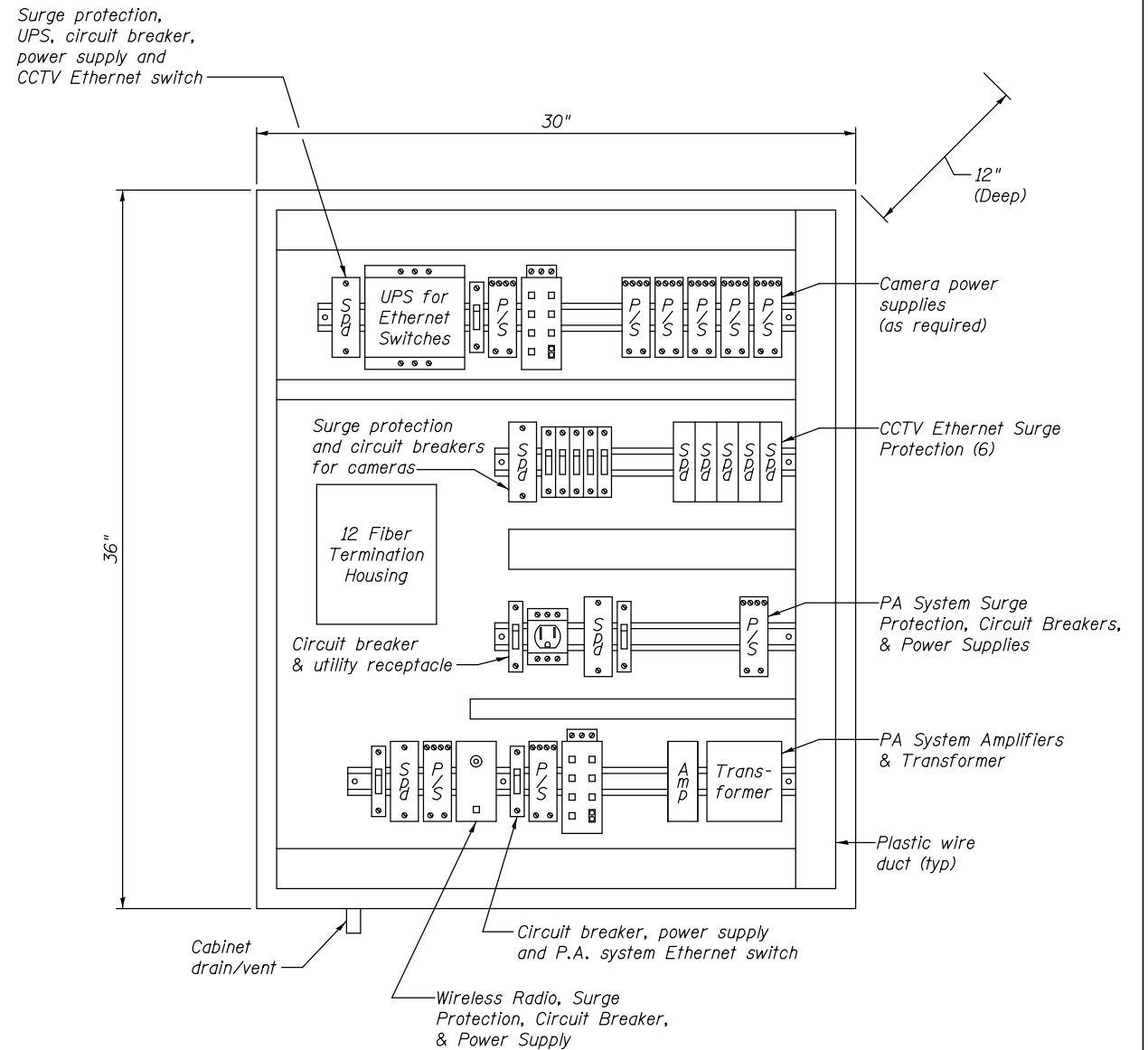

FARSIDE CCTV/P.A. CABINET

**NOTES:**

1. Rack and cabinet layouts shown are conceptual. The Contractor shall be responsible for developing and submitting layouts with all required components.
2. The Systems Integrator shall be responsible for coordinating cabinet sizing requirements to accommodate equipment serving all applicable systems.



USER NAME =	DESIGNED - R.I. PETERS	REVISED -
	CHECKED - L.V. BORDEN	REVISED -
PLOT SCALE =	DRAWN - R.I. PETERS	REVISED -
PLOT DATE =	CHECKED - K.M. GABLE	REVISED -

STATE OF ILLINOIS  
DEPARTMENT OF TRANSPORTATION

VARIOUS MOVABLE BRIDGES  
LOCAL CENTRALIZED CONTROL AND OPERATION  
BRANDON ROAD - NETWORK CABINET DETAILS  
SHEET NO. 25 OF 93 SHEETS

BRANDON, Drawing 06-025				
F.A.U. R.T.E.	SECTION	COUNTY	TOTAL SHEETS	SHEET NO.
0341	2011-045-I	WILL	466	350
CONTRACT NO. 60P55				
ILLINOIS FED. AID PROJECT				

**CAMERA LOCATIONS AND DESCRIPTIONS**

- Pedestrian cameras 1 and 2 are located on the existing roadway lighting poles and are aimed at the pedestrian sidewalks.
- Traffic cameras 1 and 2 are located on the existing aerial cable poles and are aimed at the traffic gates.
- Upper PTZ cameras 1 and 2 are located on the existing aerial cable poles. (pan-tilt-zoom type cameras)
- Thermal imaging camera 1 shall be wall mounted to the South face of the Operator's House outside the fenced perimeter and aimed downstream.
- Thermal imaging camera 2 shall be wall mounted to the East face of the North abutment outside the fenced perimeter and aimed upstream.
- Lower PTZ camera 1 shall be wall mounted to the East face of the North abutment outside the fenced perimeter and aimed under the bridge.
- Lower PTZ camera 2 shall be wall mounted to the West face of the South abutment outside the fenced perimeter and aimed under the bridge.
- Lower PTZ camera 3 shall be wall mounted to the South face of the Operator's House outside the fenced perimeter and aimed under the bridge.
- Lower PTZ camera 4 shall be wall mounted to the North face of the South Machinery House and aimed under the bridge.

**NOTES:**

1. All locations shown are approximate. The Contractor shall field verify all camera mounting locations and submit proposed mounting locations to the Engineer for approval. All camera locations shall be clear of the movable span.
2. Lower PTZ cameras' pan and tilt range of motion shall allow viewing of the area directly under the bridge.

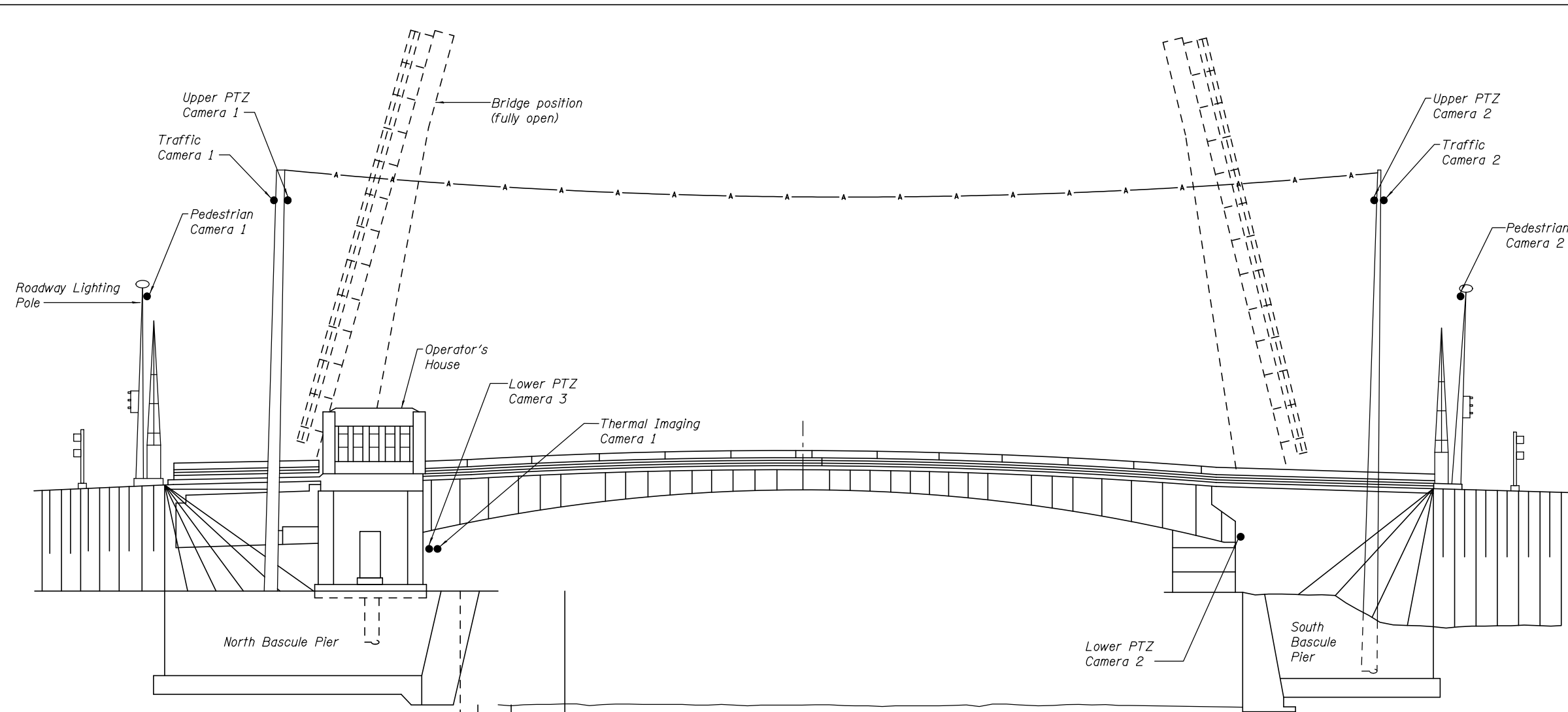

**ELEVATION**

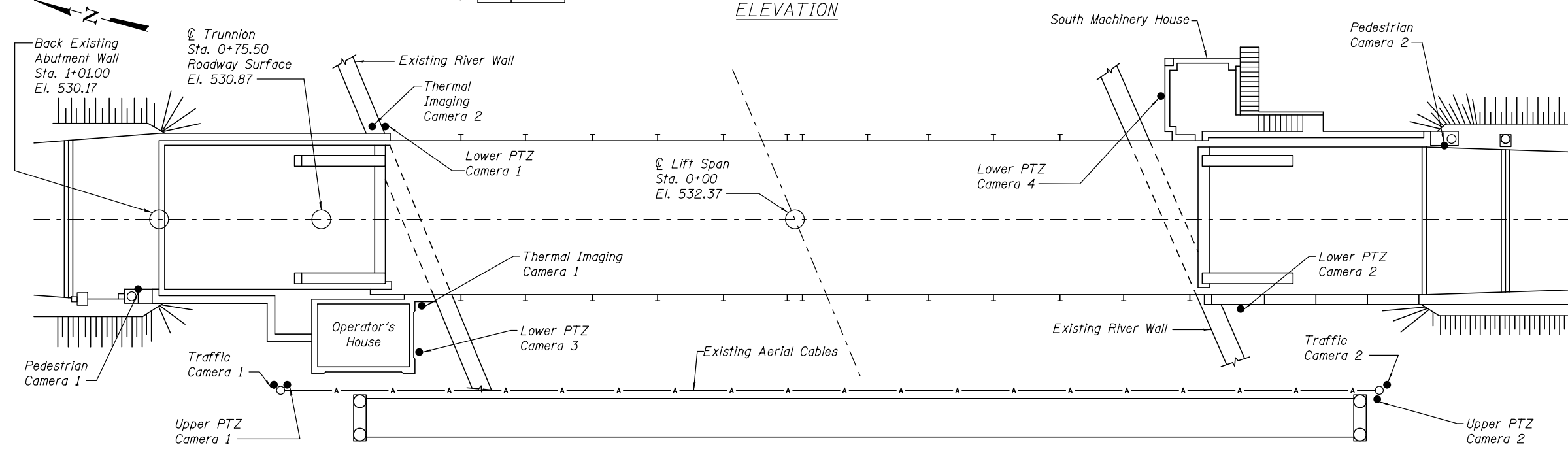

**PLAN**

	USER NAME =	DESIGNED - K.M. GABLE	REVISED -	<b>STATE OF ILLINOIS DEPARTMENT OF TRANSPORTATION</b>	<b>VARIOUS MOVABLE BRIDGES LOCAL CENTRALIZED CONTROL AND OPERATION BRANDON ROAD - CCTV PLAN AND ELEVATION</b>	F.A.U. RTE.	SECTION	COUNTY	TOTAL SHEETS	SHEET NO.	
	PLOT SCALE =	CHECKED - L.V. BORDEN	REVISED -			0341	2011-045-I	WILL	466	351	
	PLOT DATE =	DRAWN - R.S. JOHNSON	REVISED -			CONTRACT NO. 60P55					
		CHECKED - R.I. PETERS	REVISED -			SHEET NO. 26 OF 93 SHEETS					

BRANDON, Drawing 06-026  
ILLINOIS FED. AID PROJECT

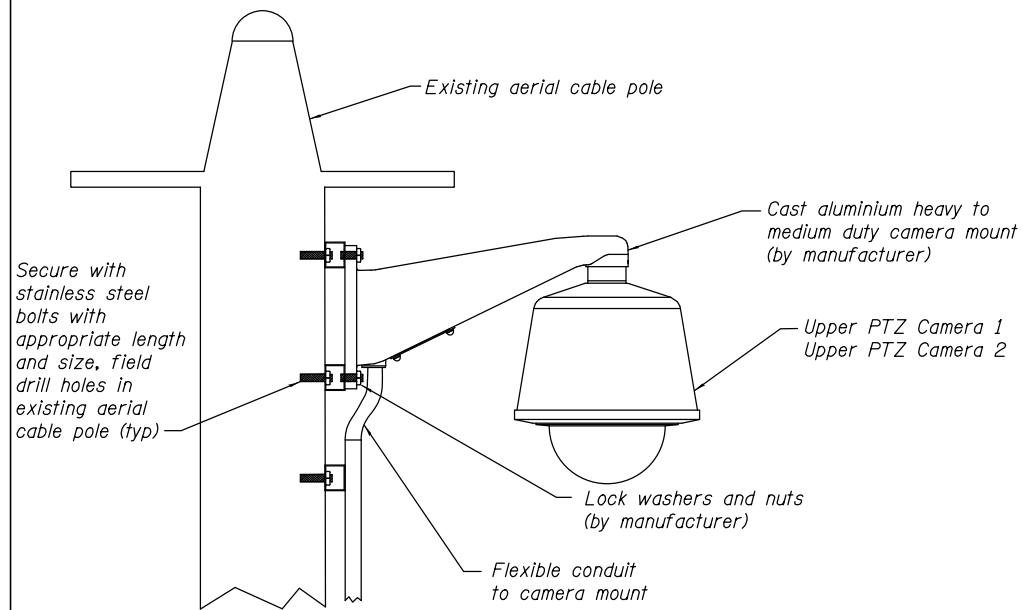

AERIAL CABLE POLE MOUNTED PTZ DOME CAMERA

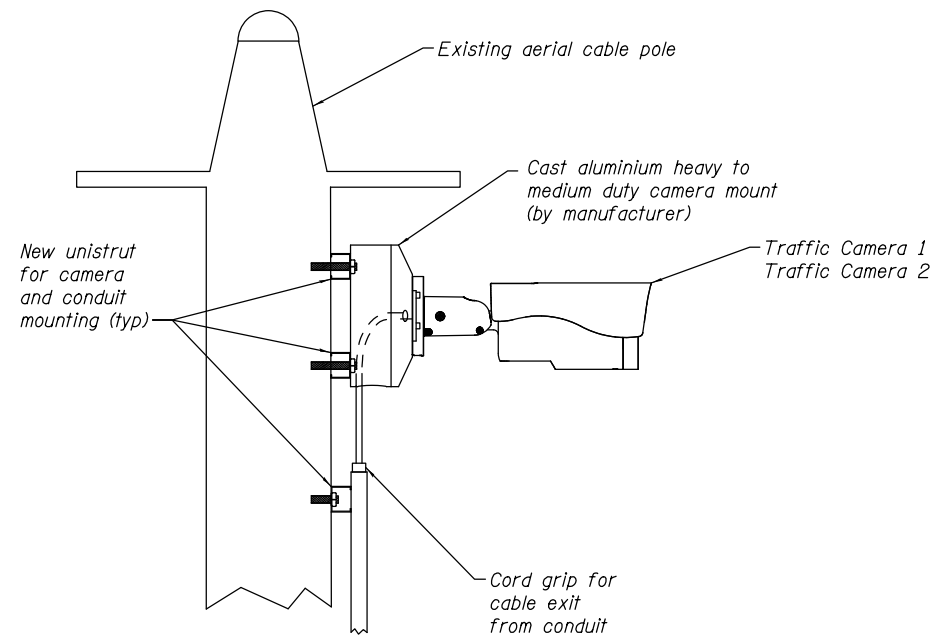

AERIAL CABLE POLE MOUNTED FIXED CAMERA

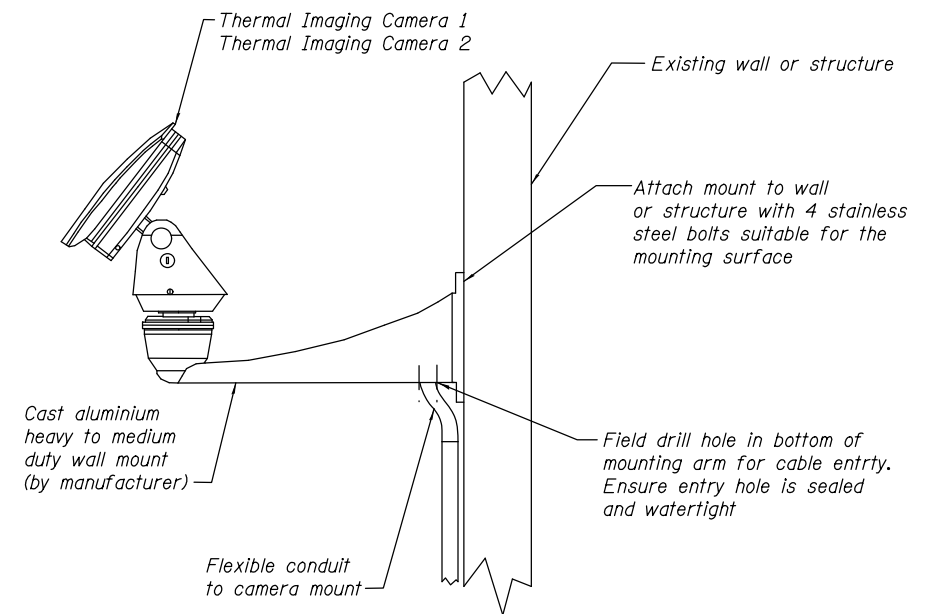

WALL OR STRUCTURE MOUNTED THERMAL IMAGING PTZ CAMERA

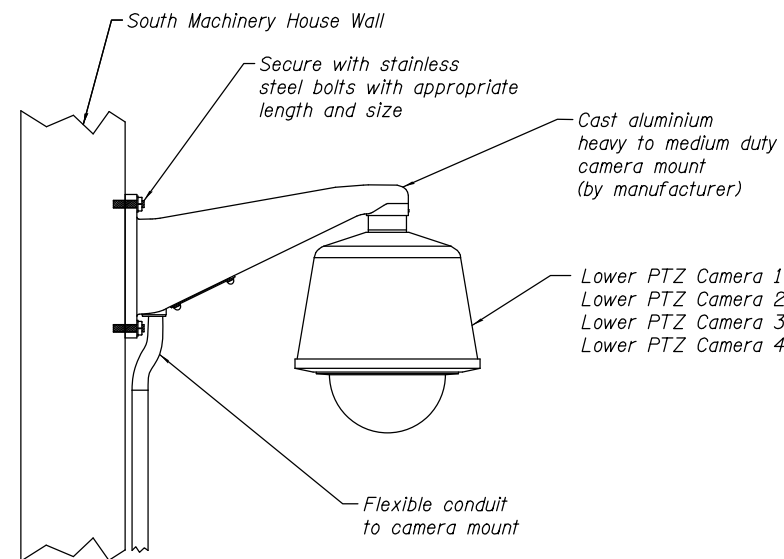

WALL OR STRUCTURE MOUNTED PTZ DOME CAMERA

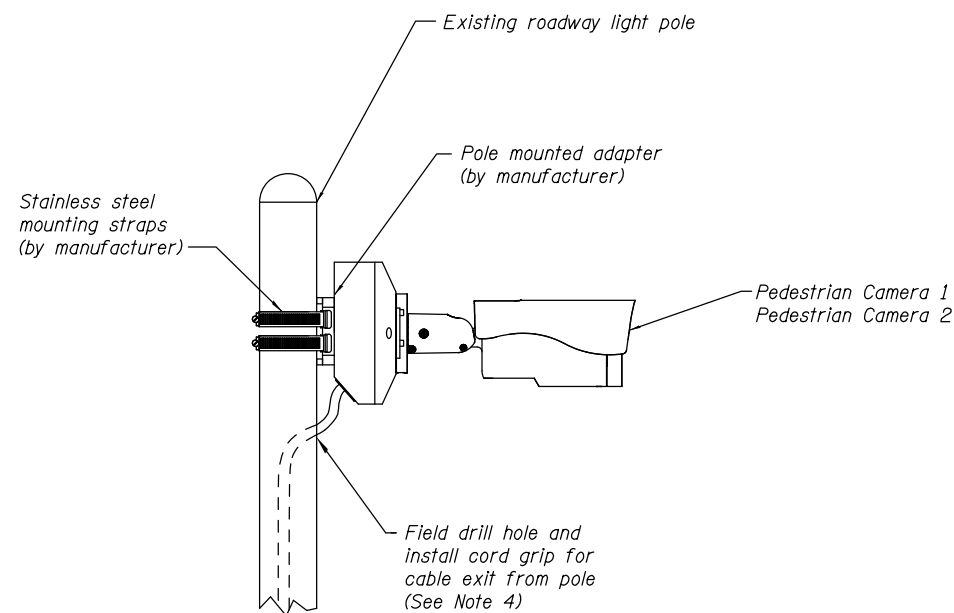

POLE MOUNTED FIXED CAMERA

**NOTES:**

1. For camera locations, refer to CCTV Plan and Elevation drawings.
2. Cable routing details provide one acceptable routing method. Routing may vary depending on camera manufacturer.
3. Refer to sheet 02-095 for typical conduit mounting details.
4. Cable entrance to pole shall be made at transformer base. Field drill hole in transformer base for conduit fitting.



USER NAME =	DESIGNED - R.I. PETERS	REVISED -
	CHECKED - L.V. BORDEN	REVISED -
PLOT SCALE =	DRAWN - R.I. PETERS	REVISED -
PLOT DATE =	CHECKED - K.M GABLE	REVISED -

**STATE OF ILLINOIS  
DEPARTMENT OF TRANSPORTATION**

**VARIOUS MOVABLE BRIDGES  
LOCAL CENTRALIZED CONTROL AND OPERATION  
BRANDON ROAD - CCTV MOUNTING DETAILS**

SHEET NO. 27 OF 93 SHEETS

BRANDON, Drawing 06-027				
F.A. RTE.	SECTION	COUNTY	TOTAL SHEETS	SHEET NO.
0341	2011-045-I	WILL	466	352
CONTRACT NO. 60P55				
ILLINOIS FED. AID PROJECT				

Bridge Operator House

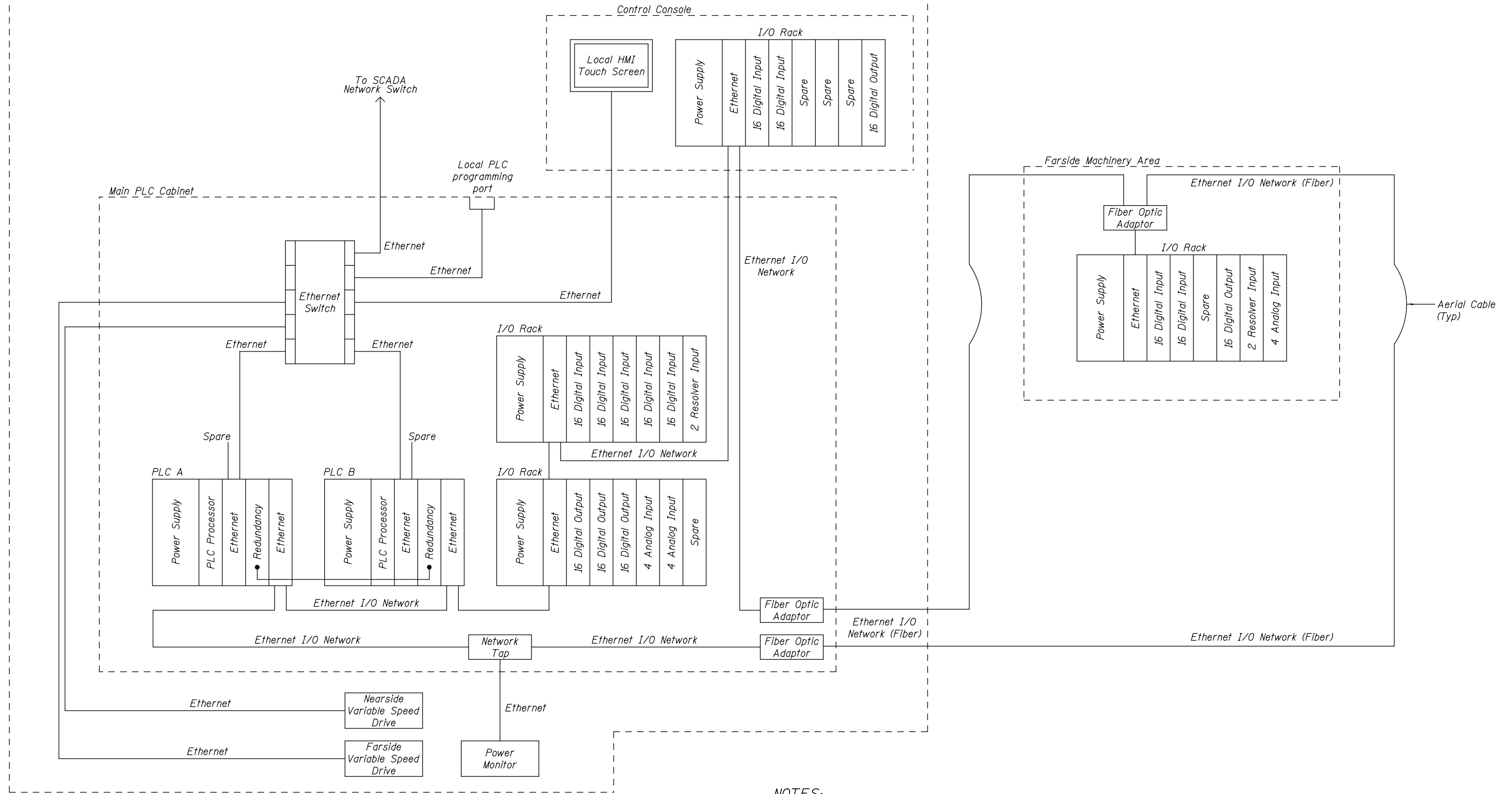

**NOTES:**

1. All PLC, HMI, and communications equipment shall be powered from a UPS power system.
2. One PLC processor (A or B) shall be active and the other shall be standby. In the event of a fault/failure in the active PLC processor, control shall automatically switch to the standby processor.
3. All equipment shown is new.



USER NAME =	DESIGNED - R.I. PETERS	REVISED -
	CHECKED - L.V. BORDEN	REVISED -
PLOT SCALE =	DRAWN - R.I. PETERS	REVISED -
PLOT DATE =	CHECKED - K.M. GABLE	REVISED -

**STATE OF ILLINOIS  
DEPARTMENT OF TRANSPORTATION**

**VARIOUS MOVABLE BRIDGES  
LOCAL CENTRALIZED CONTROL AND OPERATION  
BRANDON ROAD - BRIDGE CONTROL DIAGRAM**

SHEET NO. 28 OF 93 SHEETS

BRANDON, Drawing 06-028				
F.A.U. RTE.	SECTION	COUNTY	TOTAL SHEETS	SHEET NO.
0341	2011-045-I	WILL	466	353
CONTRACT NO. 60P55				

ILLINOIS FED. AID PROJECT

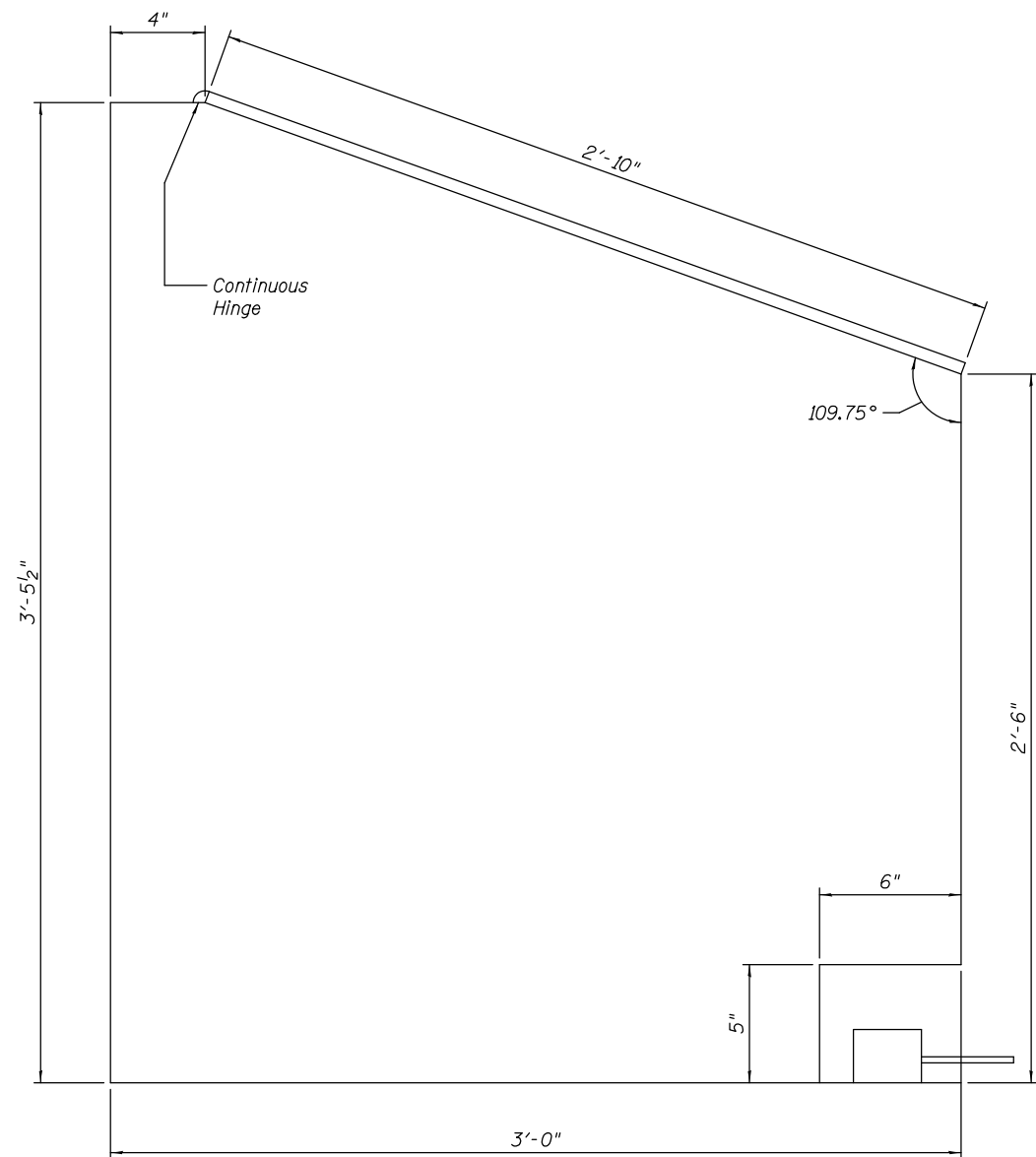

SIDE VIEW

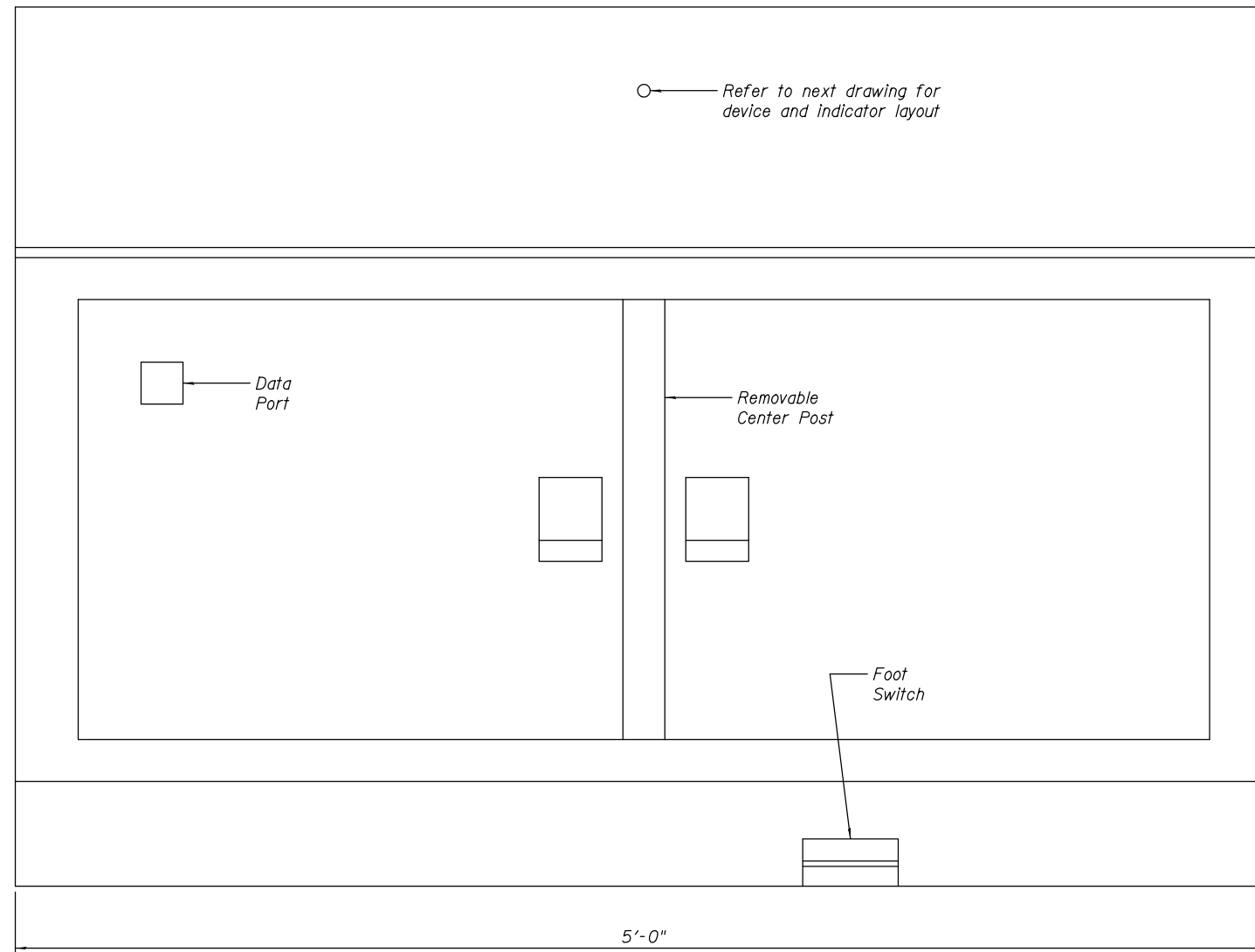

FRONT VIEW

**NOTES:**

1. All dimensions shown are approximate. The Contractor shall submit control console layout and design drawings to the Engineer for approval. Actual control console size shall be based on available operator house space, cabinet components required, and fabrication requirements.
2. Provide additional free standing tables for CCTV controller keyboard/joystick, marine radio, and general utility use. Tables shall be sized and shaped to be placed at either side of the new control console as required by individual control house dimensions. Table tops shall be composite wood or laminated construction, 1" minimum thickness with oil and moisture resistant finish. Legs, top support, cross members, and bracing shall be constructed of powder coated formed steel, minimum 16 gauge. Leg design shall allow height adjustment in 1" increments between approximately 29" to 33".



USER NAME =	DESIGNED - R.I. PETERS	REVISED	---
	CHECKED - L.V. BORDEN	REVISED	---
PLOT SCALE =	DRAWN - R.L. REED	REVISED	---
PLOT DATE =	CHECKED - R.I. PETERS	REVISED	---

**STATE OF ILLINOIS  
DEPARTMENT OF TRANSPORTATION**

**VARIOUS MOVABLE BRIDGES  
LOCAL CENTRALIZED CONTROL AND OPERATION  
BRANDON ROAD - NEW BRIDGE CONTROL CONSOLE - 1**

SHEET NO. 29 OF 93 SHEETS

F.A.U. RTE.		SECTION	COUNTY	TOTAL SHEETS	SHEET NO.
0341		2011-045-I	WILL	466	354
CONTRACT NO. 60P55					
ILLINOIS FED. AID PROJECT					

BRANDON, Drawing 06-029

5'-0"

2'-10"

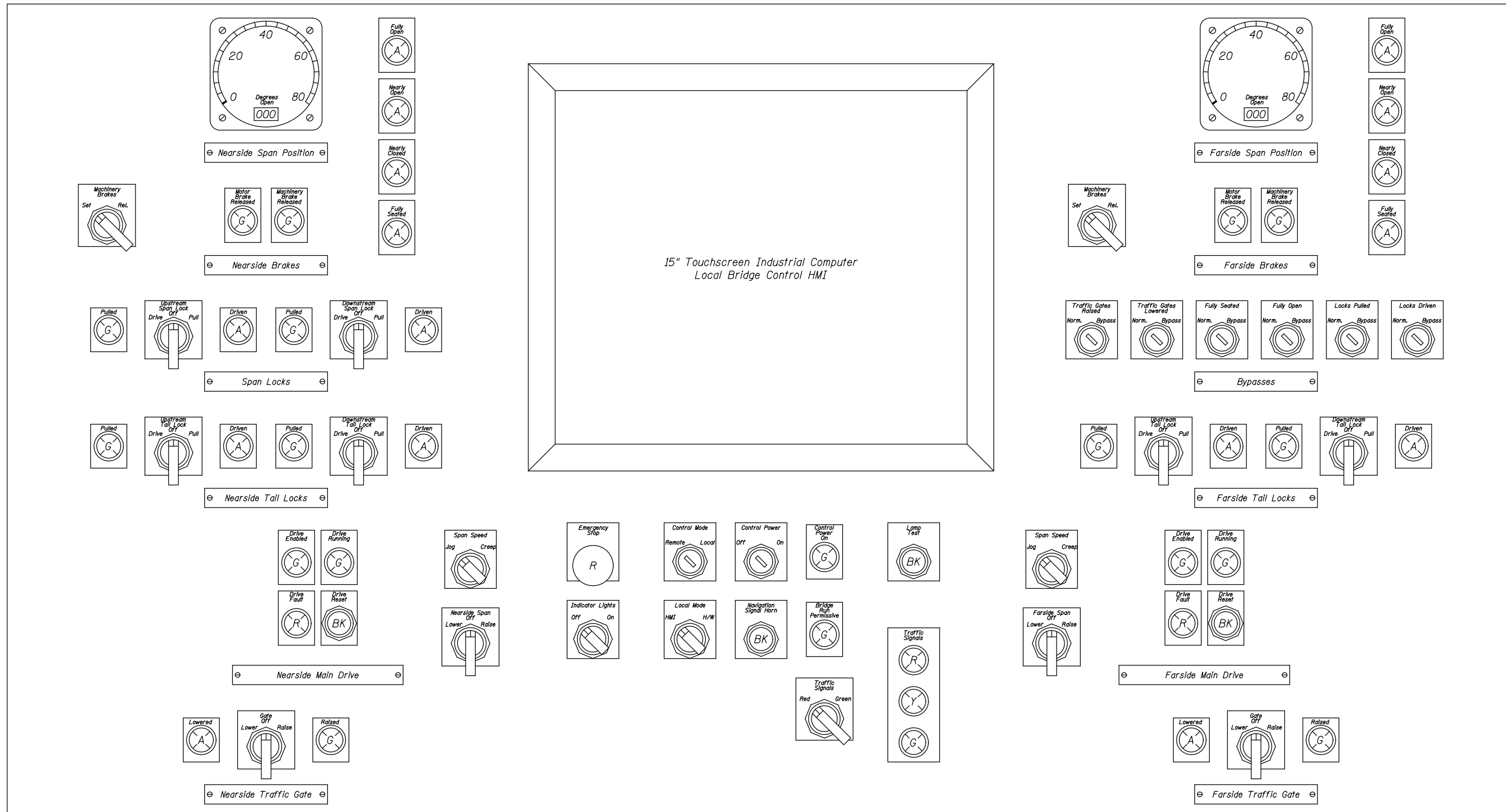

CONTROL CONSOLE DEVICE AND INDICATOR LAYOUT



USER NAME =	DESIGNED - R.I. PETERS	REVISED -
	CHECKED - L.V. BORDEN	REVISED -
PLOT SCALE =	DRAWN - R.L. REED	REVISED -
PLOT DATE =	CHECKED - R.I. PETERS	REVISED -

STATE OF ILLINOIS  
DEPARTMENT OF TRANSPORTATION

VARIOUS MOVABLE BRIDGES  
LOCAL CENTRALIZED CONTROL AND OPERATION  
BRANDON ROAD - NEW BRIDGE CONTROL CONSOLE - 2  
SHEET NO. 30 OF 93 SHEETS

F.A.U. RTE.	SECTION	COUNTY	TOTAL SHEETS	SHEET NO.
0341	2011-045-I	WILL	466	355
CONTRACT NO. 60P55				
ILLINOIS FED. AID PROJECT				

BRANDON, Drawing 06-030

**GENERAL ELECTRICAL POWER AND CONTROL CIRCUIT SCHEMATIC SYMBOLS**

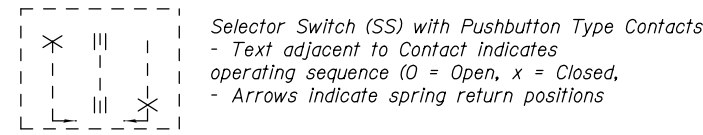
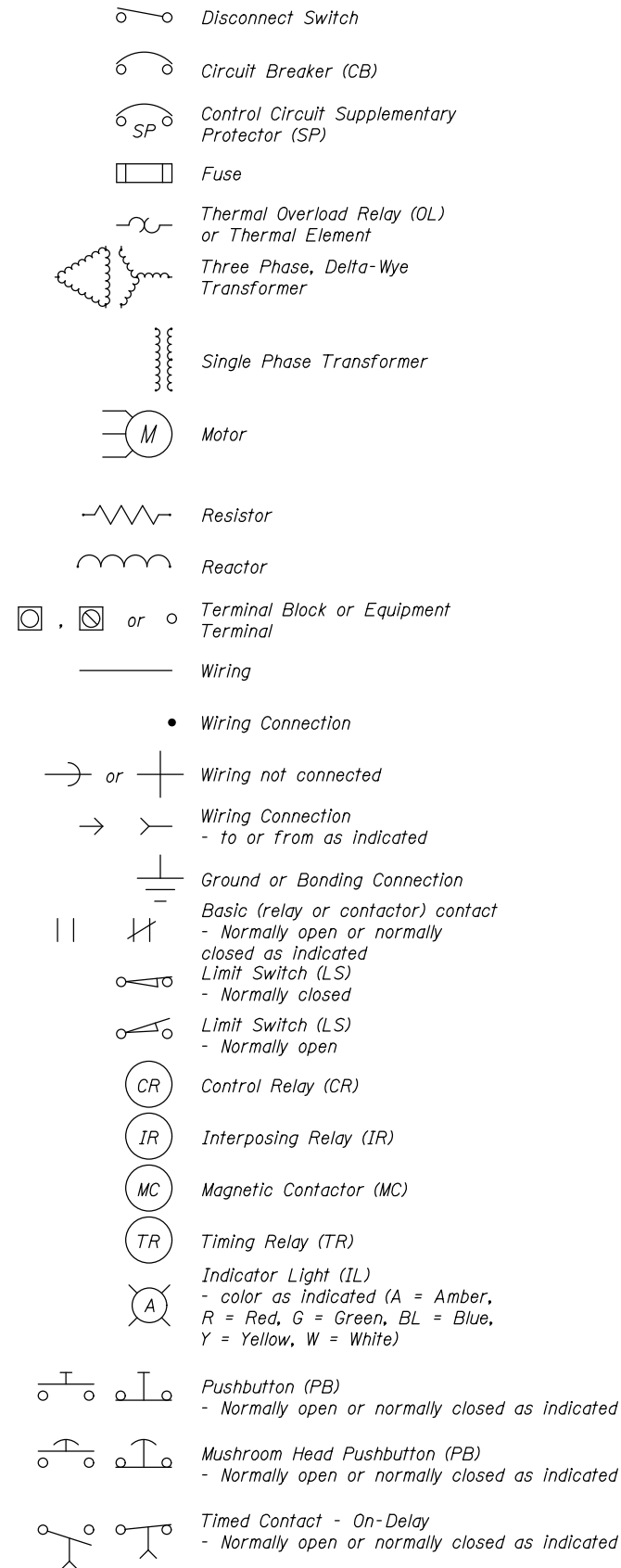

**PLC SYSTEM SYMBOLS**

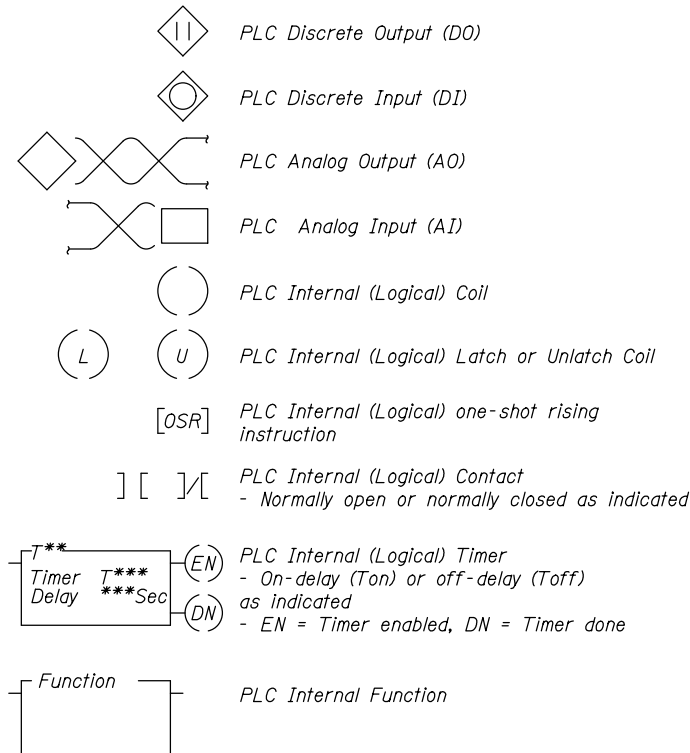

**MISCELLANEOUS**

Number in parenthesis to the left of control device (Limit Switches, Pushbuttons, Selector Switches, etc.) Contacts indicates the contact designation.

Control circuit device designations are as follows.  
 N = Nearside                      F = Farside  
 N = North                         S = South

**GENERAL LEGEND**

Symbol	Description
ACK	Acknowledged
ATS	Automatic Transfer Switch
AUT	Automatic
AUX	Auxiliary
BATT,BAT	Battery
BM	Bus Monitor
BYP	Bypass
CB	Circuit Breaker
CCTV	Closed Circuit Television
CON	Contactor
CP	Control Power
CR	Control Relay
CS	Control Switch
ES	Emergency Stop
FLT	Fault
GEN	Generator
HC	Hand Crank Mechanism
HMI	Operator Interface
HW	Hard-Wired Mode
IL	Indicator Light
IN	Inclinometer Sensor
I/O	Input/Output
IR	Interposing Relay
LOC	Local Mode (HMI or HW)
LS	Limit Switch
MAN	Manual
MC	Magnetic Contactor
MCC	Motor Control Center
MD	Main Drive
OL	Motor Overload Relay
PB	Push Button
PLC	Programmable Logic Controller
REM	Remote Mode (SCADA)
RS	Resolver Sensor
SCADA	Supervisory Control and Data Acquisition
SPD	Surge Protective Device
SP	Supplementary Protection
SS	Safety Switch or Selector Switch
SW	Switch
TMR	Timer
TR	Timing Relay
UPS	Uninterruptible Power Supply
UTIL	Utility
VFD	Variable Frequency Drive



USER NAME =	DESIGNED - R.I. PETERS	REVISED _____
	CHECKED - J.G. STRENKOSKI	REVISED _____
PLOT SCALE =	DRAWN - R.L. REED	REVISED _____
PLOT DATE =	CHECKED - J.G. STRENKOSKI	REVISED _____

**STATE OF ILLINOIS  
DEPARTMENT OF TRANSPORTATION**

**VARIOUS MOVABLE BRIDGES  
LOCAL CENTRALIZED CONTROL AND OPERATION  
BRANDON ROAD - CONTROL CIRCUIT LEGEND - 1**  
SHEET NO. 31 OF 93 SHEETS

BRANDON, Drawing 06-031				
F.A.U. RTE.	SECTION	COUNTY	TOTAL SHEETS	SHEET NO.
0341	2011-045-I	WILL	466	356
CONTRACT NO. 60P55				
ILLINOIS FED. AID PROJECT				



LOGIC DIGITAL INPUT LEGEND

Symbol	Description	Address
ATS-G	Generator Power Source Selected	I:004
ATS-GH	Generator Power Available/Healthy	I:005
ATS-U	Utility Power Source Selected	I:002
ATS-UH	Utility Power Available/Healthy	I:003
BM	Bus Monitor Fault	I:006
CR-BDET	Boat Detection (No Boat Present)	I:021
CR-CP	Control Power On	I:301
CR-DSDL	Downstream Span Lock Driven	I:039
CR-DSLP	Downstream Span Lock Pulled	I:040
CR-FDTLD	Farside Downstream Tail Lock Driven	I:047
CR-FDTLP	Farside Downstream Tail Lock Pulled	I:048
CR-FGL	Farside Gate Lowered	I:322
CR-FGR	Farside Gate Raised	I:321
CR-FTS	Foot Switch	I:308
CR-FUTLD	Farside Upstream Tail Lock Driven	I:045
CR-FUTLP	Farside Upstream Tail Lock Pulled	I:046
CR-MD-FE	Farside Main Drive Enabled	I:071
CR-MD-FF	Farside Main Drive Fault	I:073
CR-MD-FR	Farside Main Drive Running	I:072
CR-MD-NE	Nearside Main Drive Enabled	I:065
CR-MD-NF	Nearside Main Drive Fault	I:067
CR-MD-NR	Nearside Main Drive Running	I:066
CR-NDTLD	Nearside Downstream Tail Lock Driven	I:043
CR-NDTLP	Nearside Downstream Tail Lock Pulled	I:044
CR-NGL	Nearside Gate Lowered	I:318
CR-NGR	Nearside Gate Raised	I:317
CR-NUTLD	Nearside Upstream Tail Lock Driven	I:041
CR-NUTLP	Nearside Upstream Tail Lock Pulled	I:042
CR-TSR	Red Traffic Signal	I:310
CR-TSY	Yellow Traffic Signal	I:311
CR-USLD	Upstream Span Lock Driven	I:037
CR-USLP	Upstream Span Lock Pulled	I:038
CS-HW(H/W)	Local Console Hard-wired Switch Controls	I:305
CS-HW(HMI)	Local HMI Controls	I:306
CS-REM(REM)	Remote Scada Control Mode	I:303
CS-REM(LOC)	Local Control Mode	I:304
LS-FBAS	Farside Motor Brake A Set	I:717
LS-FBAR	Farside Motor Brake A Released	I:718
LS-FBAHR	Farside Motor Brake A Hand Released	I:725
LS-FBBS	Farside Machinery Brake B Set	I:719
LS-FBBR	Farside Machinery Brake B Released	I:720
LS-FBBHR	Farside Machinery Brake B Hand Released	I:726
LS-FFS	Farside Fully Seated	I:704
LS-FSC(1)	Farside Fully Open	I:705
LS-FSC(2)	Farside Nearly Open	I:706
LS-FSC(3)	Farside Nearly Closed	I:707
LS-FSC(4)	Farside Fully Closed	I:708
LS-NBAS	Nearside Motor Brake A Set	I:054
LS-NBAR	Nearside Motor Brake A Released	I:055
LS-NBAHR	Nearside Motor Brake A Hand Released	I:058
LS-NBBS	Nearside Machinery Brake B Set	I:056
LS-NBBR	Nearside Machinery Brake B Released	I:057
LS-NBBHR	Nearside Machinery Brake B Hand Released	I:059
LS-NFS	Nearside Fully Seated	I:504
LS-NSC(1)	Nearside Fully Open	I:505
LS-NSC(2)	Nearside Nearly Open	I:506

LOGIC DIGITAL INPUT LEGEND (CONTINUED)

Symbol	Description	Address
LS-NSC(3)	Nearside Nearly Closed	I:507
LS-NSC(4)	Nearside Fully Closed	I:508
PB-ES	Emergency Stop Push Button	I:302
PB-WH	Push Button Warning Horn	I:307
SPD	Surge Protective Device Status	I:001
	CCTV UPS Low Battery	I:332
	CCTV UPS Fault	I:331
	Farside I/O Low Battery	I:702
	Farside I/O Fault	I:701
	Farside Machinery Door Switches	I:703
	Operator House Second Floor Fire Alarm	I:018
	Operator House Operator Room Fire Alarm	I:019
	Operator House Electrical Room Fire Alarm	I:020
	Main UPS Low Battery	I:008
	Main UPS Fault	I:007
	Nearside Machinery Door Switches	I:503
	Operator House-Main Door Switch (Lower Level)	I:011
	Operator House-Roadway Door Switch (Upper Level)	I:012

LOGIC DIGITAL OUTPUT LEGEND

Symbol	Description	Address
CR-BAGR	Bypass All Gates Raised	O:354
CR-BSFS	Bypass Span Fully Seated	O:355
CR-FMWH	Farside Machinery Area Warning Horn	O:765
CR-NMWH	Nearside Machinery Area Warning Horn	O:565
CR-RR	Request Red Traffic Signal	O:353
CR-WH	Warning Horn	O:362
IR-DDSL	Drive Downstream Span Lock	O:134
IR-DFDTL	Drive Farside Downstream Tail Lock	O:114
IR-DFUTL	Drive Farside Upstream Tail Lock	O:112
IR-DNDTL	Drive Nearside Downstream Tail Lock	O:110
IR-DNUTL	Drive Nearside Upstream Tail Lock	O:108
IR-DUSL	Drive Upstream Span Lock	O:132
IR-LFG	Lower Farside Traffic Gate	O:102
IR-LNG	Lower Nearside Traffic Gate	O:100
IR-MDFC	Farside Main Drive Creep Speed	O:130
IR-MDFE	Enable Farside Main Drive	O:124
IR-MDFJ	Farside Main Drive Jog Speed	O:129
IR-MDFL	Farside Main Drive Lower	O:126
IR-MDFR	Farside Main Drive Raise	O:125
IR-MDFS	Reset Farside Drive Fault	O:131
IR-MDFT	Farside Main Drive Reduced Torque Mode	O:127
IR-MDNC	Nearside Main Drive Creep Speed	O:122
IR-MDNE	Enable Nearside Main Drive	O:116
IR-MDNJ	Nearside Main Drive Jog Speed	O:121
IR-MDNL	Nearside Main Drive Lower	O:118
IR-MDNR	Nearside Main Drive Raise	O:117
IR-MDNS	Reset Nearside Drive Fault	O:123
IR-MDNT	Nearside Main Drive Reduced Torque Mode	O:119
IR-PDSL	Pull Downstream Span Lock	O:135
IR-PFDTL	Pull Farside Downstream Tail Lock	O:115
IR-PFUTL	Pull Farside Upstream Tail Lock	O:113
IR-PNDTL	Pull Nearside Downstream Tail Lock	O:111
IR-PNUTL	Pull Nearside Upstream Tail Lock	O:109
IR-PUSL	Pull Upstream Span Lock	O:133
IR-RFBA	Farside Motor Brake A Release	O:106
IR-RFBB	Farside Machinery Brake B Release	O:107
IR-RFG	Raise Farside Traffic Gate	O:103
IR-RNBA	Nearside Motor Brake A Release	O:104
IR-RNBB	Nearside Machinery Brake B Release	O:105
IR-RNG	Raise Nearside Traffic Gate	O:101
IR-SES1	Software Emergency Stop Relay 1	O:349
IR-SES2	Software Emergency Stop Relay 2	O:350
IR-SCP1	Software Control Power Relay 1	O:351
IR-SCP2	Software Control Power Relay 2	O:352

LOGIC ANALOG/SPECIALTY INPUT LEGEND

Symbol	Description	Address
	Analog Input Far Drive Speed	I:182
	Analog Input Far Drive Torque	I:183
	Analog Input Near Drive Speed	I:180
	Analog Input Near Drive Torque	I:181
	Analog PLC Input Farside Resolver	I:790
	Analog PLC Input Farside Inclinator	I:794
	Analog PLC Input Nearside Resolver	I:590
	Analog PLC Input Nearside Inclinator	I:594



USER NAME =	DESIGNED - R.I. PETERS	REVISED -
	CHECKED - J.G. STRENKOSKI	REVISED -
PLOT SCALE =	DRAWN - R.I. PETERS	REVISED -
PLOT DATE =	CHECKED - J.G. STRENKOSKI	REVISED -

STATE OF ILLINOIS  
DEPARTMENT OF TRANSPORTATION

VARIOUS MOVABLE BRIDGES  
LOCAL CENTRALIZED CONTROL AND OPERATION  
BRANDON ROAD - CONTROL CIRCUIT LEGEND - 2

F.A.U. RTE.	SECTION	COUNTY	TOTAL SHEETS	SHEET NO.
0341	2011-045-I	WILL	466	357
CONTRACT NO. 60P55				
ILLINOIS FED. AID PROJECT				

PLC LOGIC BINARY LEGEND

Symbol	Description
ADE	All Drives Enabled
AGL	All Gates Lowered
AGR	All Gates Raised
ALD	All Locks Driven
ALP	All Locks Pulled
BDET	Boat Detection
BMF	Bus Monitor Fault
BRP	Bridge Run Permissive
BYP AGL	Bypass All Traffic Gates Lowered
BYP AGR	Bypass All Traffic Gates Raised
BYP ALD	Bypass All Locks Driven
BYP ALP	Bypass All Locks Pulled
BYP FO	Bypass Bridge Fully Open
BYP FS	Bypass Bridge Fully Seated
BYP SFO	Bypass Span Fully Open
BYP SFS	Bypass Span Fully Seated
BYP INHIB	Bypass Inhibit
DSL	Downstream Span Lock
FDTL	Farside Downstream Tail Lock
FFC	Farside Fully Closed
FFO	Farside Fully Open
FFS	Farside Fully Seated
FFS1	Farside Span Fully Seated (Set Brakes)
FFS2	Farside Span Fully Seated (De-energize Drives)
FG	Farside Gate
FL	Farside Lower
FNC	Farside Nearly Closed
FNO	Farside Nearly Open
FO	Bridge Fully Open
FOS	Farside Span Overspeed
FR	Farside Raise
FS	Bridge Fully Seated
FUTL	Farside Upstream Tail Lock
IN-F	Farside Span Position PLC Inclinomter
IN-N	Nearside Span Position PLC Inclinomter
MAF	Major Fault
MDN-R	Near Main Drive Raise
MDF-R	Far Main Drive Raise
MIF	Minor Fault
ML	Master Lower
MR	Master Raise
NDTL	Nearside Downstream Tail Lock
NFC	Nearside Fully Closed
NFO	Nearside Fully Open
NFS	Nearside Fully Seated
NFS1	Nearside Span Fully Seated (Set Brakes)
NFS2	Nearside Span Fully Seated (De-energize Drives)
NG	Nearside Gate
NL	Nearside Lower
NNC	Nearside Nearly Closed
NNO	Nearside Nearly Open
NOS	Nearside Span Overspeed
NR	Nearside Raise
NS	Normal Stop
NUTL	Nearside Upstream Tail Lock
SFS	Span Fully Seated
TSG	Traffic Signal Green

PLC LOGIC BINARY LEGEND (CONTINUED)

Symbol	Description
TSR	Traffic Signal Red
TSY	Traffic Signal Yellow
UMAF	Unacknowledged Major Fault
UMIF	Unacknowledged Minor Fault
USL	Upstream Span Lock
WH-DLY	Warning Horn Delay Before Bridge Movement

HARDWIRED LEGEND

CR-FONAV	Bridge Fully Open Navigation Lights Power
CR-FSCFC	Farside Span Control Fully Closed
CR-FSCFO	Farside Span Control Fully Open
CR-FSCNC	Farside Span Control Nearly Closed
CR-FSCNO	Farside Span Control Nearly Open
CR-GNG	Traffic Gate Gong
CR-MDFC	Main Drive Far Creep Speed
CR-MDFE	Main Drive Far Enable
CR-MDFL	Main Drive Far Lower
CR-MDFJ	Main Drive Far Jog Speed
CR-MDFR	Main Drives Far Raise
CR-MDFS	Main Drive Far Reset
CR-MDFT	Farside Main Drive Reduced Torque
CR-MDNC	Main Drives Near Creep Speed
CR-MDNE	Main Drive Near Enable
CR-MDNL	Main Drive Near Lower
CR-MDNJ	Main Drive Near Jog Speed
CR-MDNR	Main Drive Near Raise
CR-MDNS	Main Drive Near Reset
CR-MDNT	Nearside Main Drive Reduced Torque
CR-MSCFL	Manual Span Control Farside Lower
CR-MSCFR	Manual Span Control Farside Raise
CR-MSCNL	Manual Span Control Nearside Lower
CR-MSCNR	Manual Span Control Nearside Raise
CR-NSCFC	Nearside Span Control Fully Closed
CR-NSCFO	Nearside Span Control Fully Open
CR-NSCNC	Nearside Span Control Nearly Closed
CR-NSCNO	Nearside Span Control Nearly Open
CR-RFB	Farside Release Brakes
CR-RNB	Nearside Release Brakes
CR-WHT	Warning Horn Timing Control Relay
CS-BAGL	Bypass All Gates Lowered
CS-BAGR	Bypass All Gates Raised
CS-BALD	Bypass All Locks Driven
CS-BALP	Bypass All Gates Pulled
CS-BSFO	Bypass Span Fully Open
CS-BSFS	Bypass Span Fully Seated
CS-DSL	Downstream Span Lock, Pull or Drive
CS-FBR	Farside Brake Select, Set or Release
CS-FDTL	Farside Downstream Tail Lock, Pull or Drive
CS-FG	Farside Traffic Gate Select, Raise or Lower
CS-FUTL	Farside Upstream Tail Lock, Pull or Drive
CS-IL	Indicator Lights Power Select, On or Off
CS-MSCF	Manual Span Control Far Select, Raise or Lower
CS-MSCN	Manual Span Control Near Select, Raise or Lower
CS-MSSF	Manual Span Speed Far Select, Jog or Creep
CS-MSSN	Manual Span Speed Near Select, Jog or Creep
CS-NBR	Nearside Brake Select, Set or Release

HARDWIRED LEGEND (CONTINUED)

Symbol	Description
CS-NDTL	Nearside Downstream Tail Lock, Pull or Drive
CS-NG	Nearside Traffic Gate Select, Raise or Lower
CS-NUTL	Nearside Upstream Tail Lock, Pull or Drive
CS-TSR	Traffic Signals to Red Light
CS-USL	Upstream Span Lock, Pull or Drive
IN-FHW	Farside Span Position Inclinomter
IN-NHW	Nearside Span Position Inclinomter
MC-DDSL	Downstream Span Lock Drive Motor Starter
MC-DFDTL	Farside Downstream Tail Lock Drive Motor Starter
MC-DFUTL	Farside Upstream Tail Lock Drive Motor Starter
MC-DNDTL	Nearside Downstream Tail Lock Drive Motor Starter
MC-DNUTL	Nearside Upstream Tail Lock Drive Motor Starter
MC-DUSL	Upstream Span Lock Drive Motor Starter
MC-LFG	Farside Traffic Gate Lower Motor Starter
MC-LNG	Nearside Traffic Gate Lower Motor Starter
MC-PDSL	Downstream Span Lock Pull Motor Starter
MC-PFDTL	Farside Downstream Tail Lock Pull Motor Starter
MC-PFUTL	Farside Upstream Tail Lock Pull Motor Starter
MC-PNDTL	Nearside Downstream Tail Lock Pull Motor Starter
MC-PNUTL	Nearside Upstream Tail Lock Pull Motor Starter
MC-PUSL	Upstream Span Lock Pull Motor Starter
MC-RFBA	Farside Main Motor Brake A Motor Starter
MC-RFBB	Farside Machinery Brake B Motor Starter
MC-RFG	Farside Traffic Gate Raise Motor Starter
MC-RNBA	Nearside Main Motor Brake A Motor Starter
MC-RNBB	Nearside Machinery Brake B Motor Starter
MC-RNG	Nearside Traffic Gate Raise Motor Starter
PB-MNRS	Nearside Main Drive Fault Reset
PB-MFRS	Farside Main Drive Fault Reset
PB-WH	Warning Horn, Push Button

HARDWIRED TIMING RELAYS

TR-BDETF	Boat Detected Fault
TR-FFS1	Farside Span Fully Seated (Set Brakes) Delay
TR-FFS2	Farside Span Fully Seated (Deenergize Drives) Delay
TR-NFS1	Nearside Span Fully Seated (Set Brakes) Delay
TR-NFS2	Nearside Span Fully Seated (Deenergize Drives) Delay
TR-TSY	Traffic Signal Yellow Time
TR-WH	Warning Horn Time

PLC TIMERS

T1	Bus Monitor Timer
T2	Boat Detection Timer
T3	Farside Fully Seated Timer 1
T4	Farside Fully Seated Timer 2
T5	Nearside Fully Seated Timer 1
T6	Nearside Fully Seated Timer 2
T7	Warning Horn Timer



USER NAME =	DESIGNED - R.I. PETERS	REVISED _____
	CHECKED - J.G. STRENKOSKI	REVISED _____
PLOT SCALE =	DRAWN - R.I. PETERS	REVISED _____
PLOT DATE =	CHECKED - J.G. STRENKOSKI	REVISED _____

STATE OF ILLINOIS  
DEPARTMENT OF TRANSPORTATION

VARIOUS MOVABLE BRIDGES  
LOCAL CENTRALIZED CONTROL AND OPERATION  
BRANDON ROAD - CONTROL CIRCUIT LEGEND - 3

SHEET NO. 33 OF 93 SHEETS

BRANDON, Drawing 06-033				
F.A.U. RTE.	SECTION	COUNTY	TOTAL SHEETS	SHEET NO.
0341	2011-045-I	WILL	466	358
CONTRACT NO. 60P55				
ILLINOIS FED. AID PROJECT				

Control Power Circuits

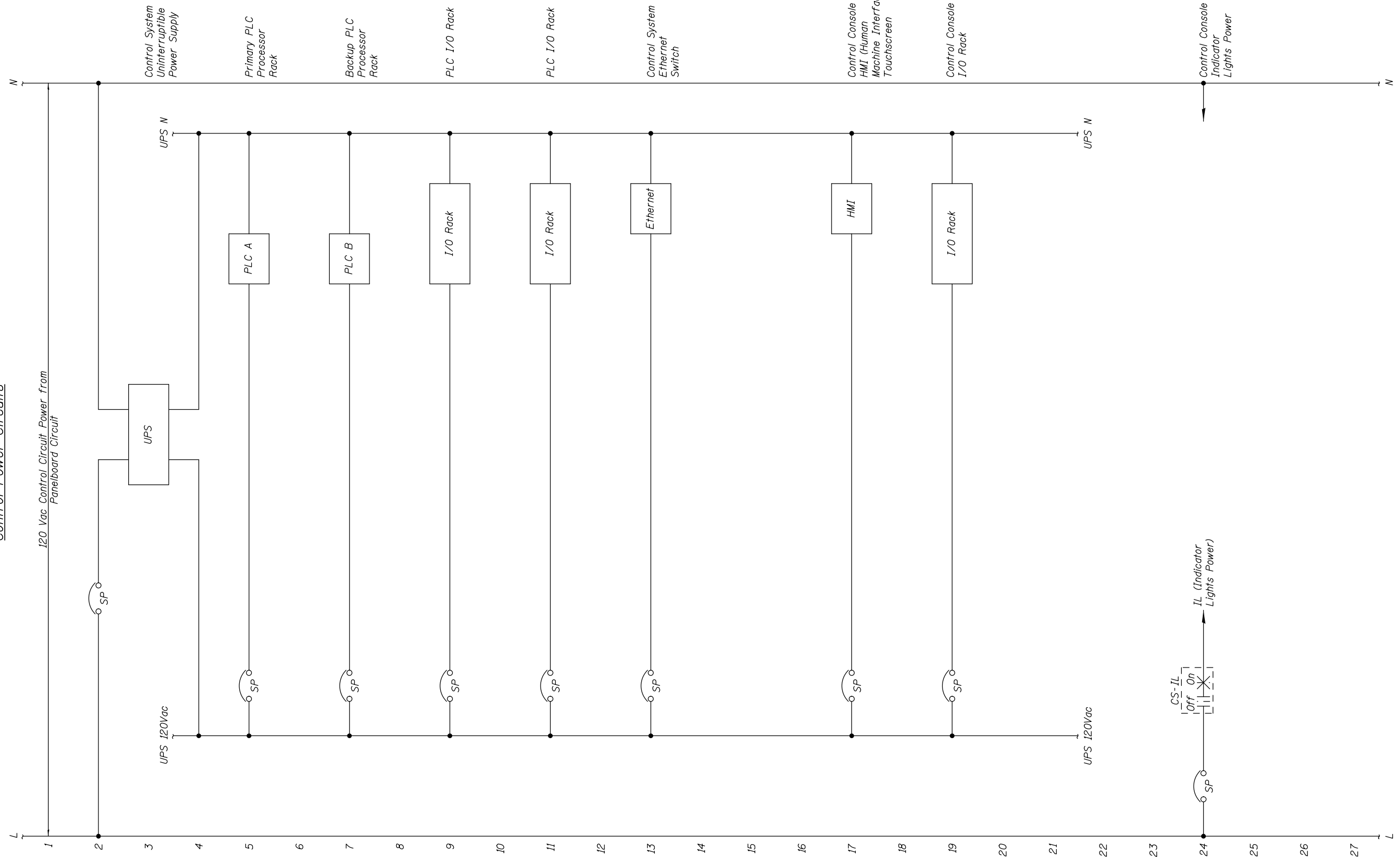

USER NAME =	DESIGNED - R.I. PETERS	REVISED	---
	CHECKED - J.G. STRENKOSKI	REVISED	---
PLOT SCALE =	DRAWN - R.I. PETERS	REVISED	---
PLOT DATE =	CHECKED - J.G. STRENKOSKI	REVISED	---

STATE OF ILLINOIS  
DEPARTMENT OF TRANSPORTATION

VARIOUS MOVABLE BRIDGES  
LOCAL CENTRALIZED CONTROL AND OPERATION  
BRANDON ROAD - CONTROL CIRCUIT - 1

SHEET NO. 34 OF 93 SHEETS

F.A.U. RTE.		SECTION	COUNTY	TOTAL SHEETS	SHEET NO.
0341		2011-045-I	WILL	466	359
CONTRACT NO. 60P55					

ILLINOIS FED. AID PROJECT

BRANDON, Drawing 06-034

Control Power Circuits

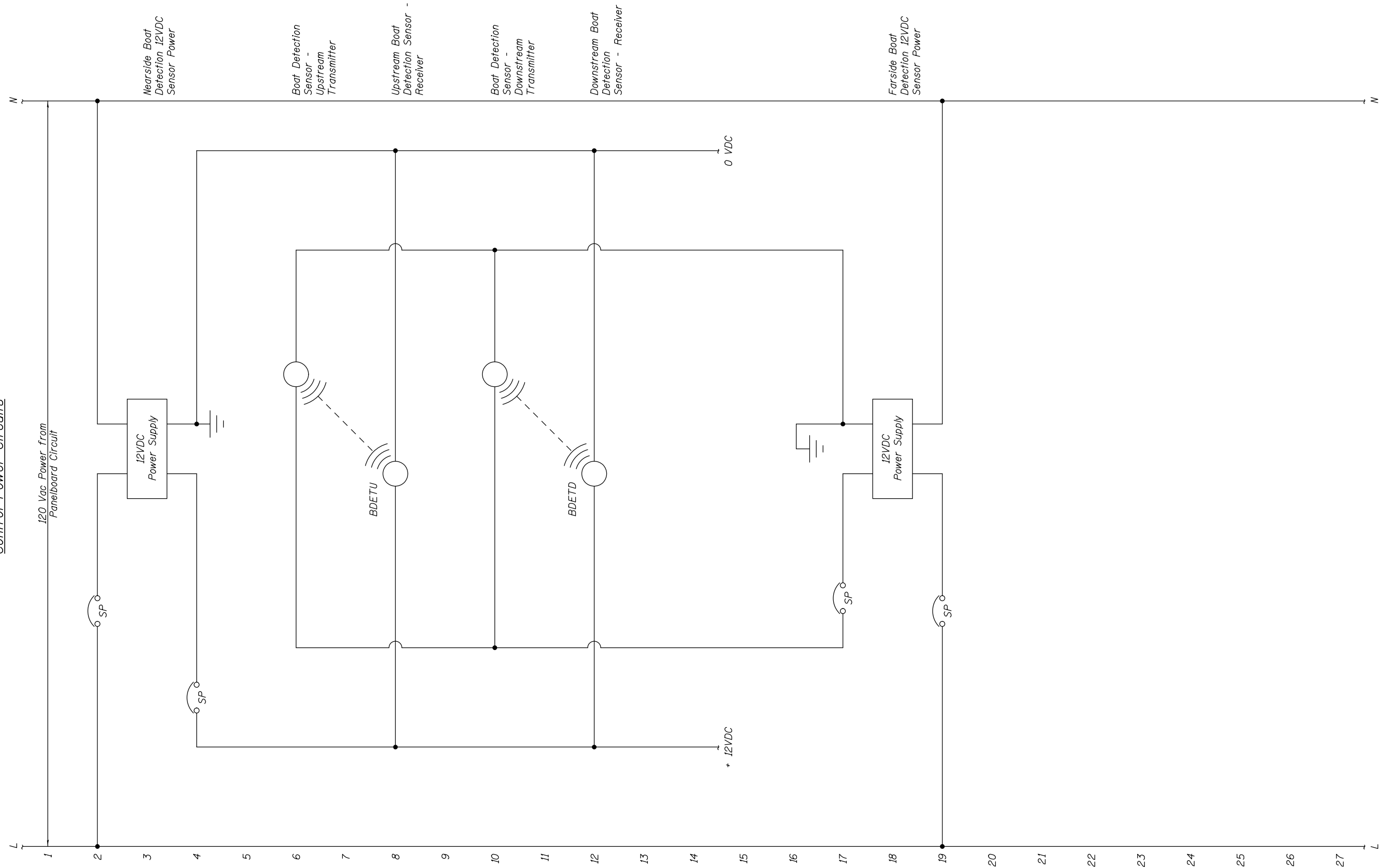

USER NAME =	DESIGNED - R.I. PETERS	REVISED	---
	CHECKED - J.G. STRENKOSKI	REVISED	---
PLOT SCALE =	DRAWN - R.I. PETERS	REVISED	---
PLOT DATE =	CHECKED - J.G. STRENKOSKI	REVISED	---

STATE OF ILLINOIS  
DEPARTMENT OF TRANSPORTATION

VARIOUS MOVABLE BRIDGES  
LOCAL CENTRALIZED CONTROL AND OPERATION  
BRANDON ROAD - CONTROL CIRCUIT - 2

SHEET NO. 35 OF 93 SHEETS

F.A.U. RTE.	SECTION	COUNTY	TOTAL SHEETS	SHEET NO.
0341	2011-045-I	WILL	466	360
CONTRACT NO. 60P55				
ILLINOIS FED. AID PROJECT				

BRANDON, Drawing 06-035

Control Power Circuits

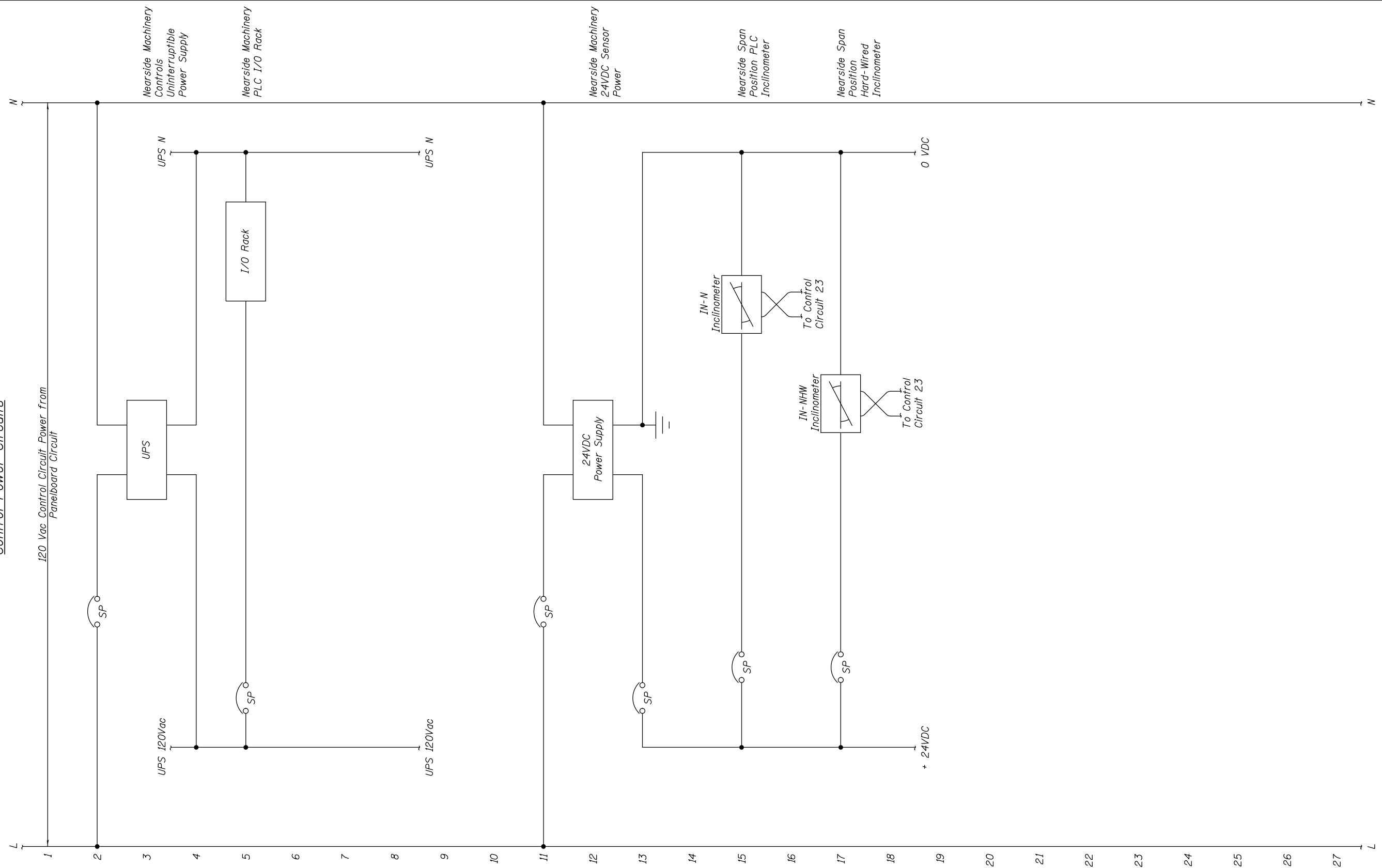

USER NAME =	DESIGNED - R.I. PETERS	REVISED	---
	CHECKED - J.G. STRENKOSKI	REVISED	---
PLOT SCALE =	DRAWN - R.I. PETERS	REVISED	---
PLOT DATE =	CHECKED - J.G. STRENKOSKI	REVISED	---

STATE OF ILLINOIS  
DEPARTMENT OF TRANSPORTATION

VARIOUS MOVABLE BRIDGES  
LOCAL CENTRALIZED CONTROL AND OPERATION  
BRANDON ROAD - CONTROL CIRCUIT - 3

SHEET NO. 36 OF 93 SHEETS

BRANDON, Drawing 06-036			
F.A.U. RTE.	SECTION	COUNTY	TOTAL SHEETS
0341	2011-045-I	WILL	466
			SHEET NO. 361
CONTRACT NO. 60P55			
ILLINOIS FED. AID PROJECT			

*Control Power Circuits*

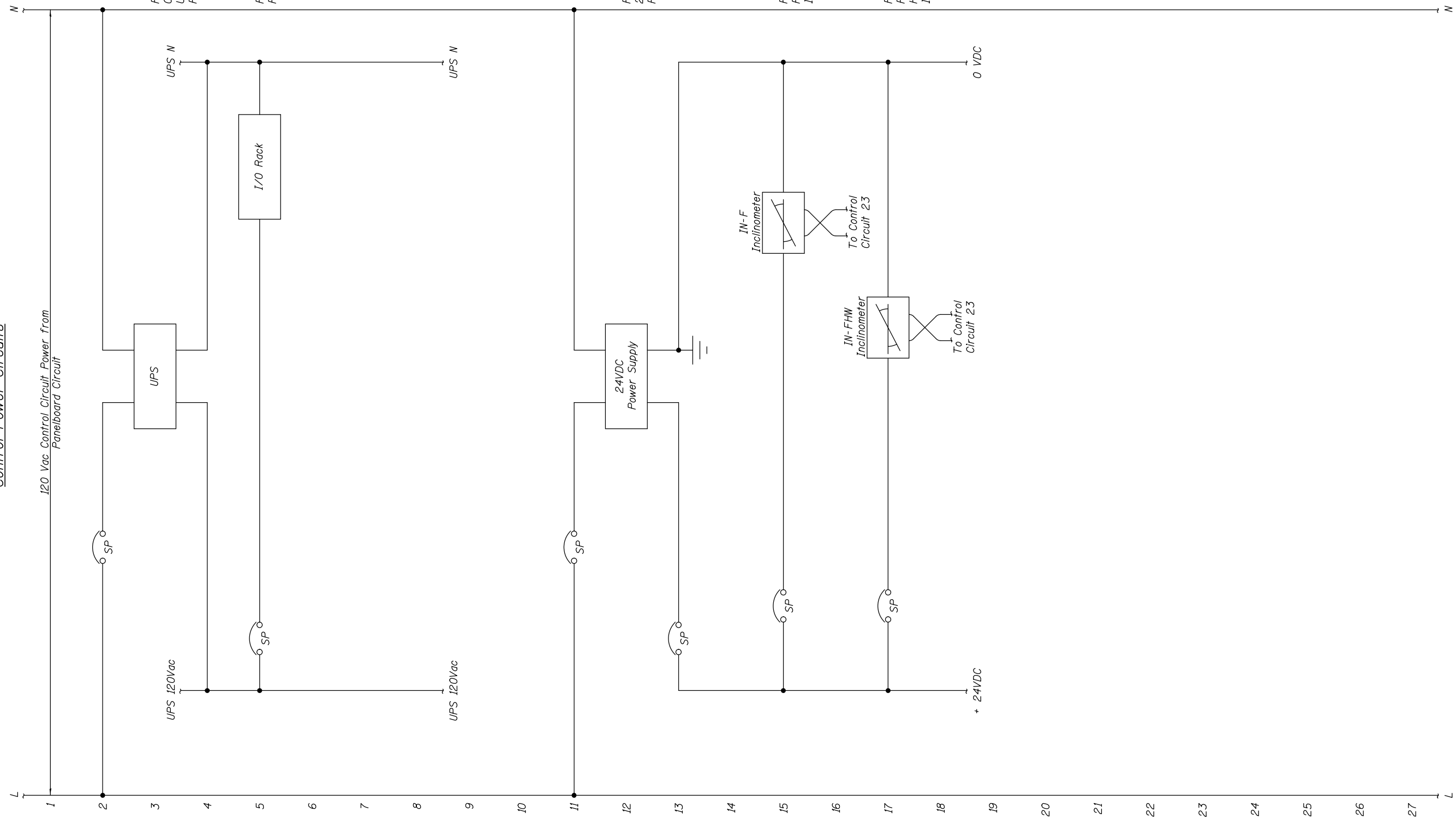

USER NAME =	DESIGNED - R.I. PETERS	REVISED	---
	CHECKED - J.G. STRENKOSKI	REVISED	---
PLOT SCALE =	DRAWN - R.I. PETERS	REVISED	---
PLOT DATE =	CHECKED - J.G. STRENKOSKI	REVISED	---

**STATE OF ILLINOIS  
DEPARTMENT OF TRANSPORTATION**

**VARIOUS MOVABLE BRIDGES  
LOCAL CENTRALIZED CONTROL AND OPERATION  
BRANDON ROAD - CONTROL CIRCUIT - 4**

SHEET NO. 37 OF 93 SHEETS

BRANDON, Drawing 06-037			
F.A.U. RTE.	SECTION	COUNTY	TOTAL SHEETS
0341	2011-045-I	WILL	466
			SHEET NO. 362
CONTRACT NO. 60P55			
ILLINOIS FED. AID PROJECT			

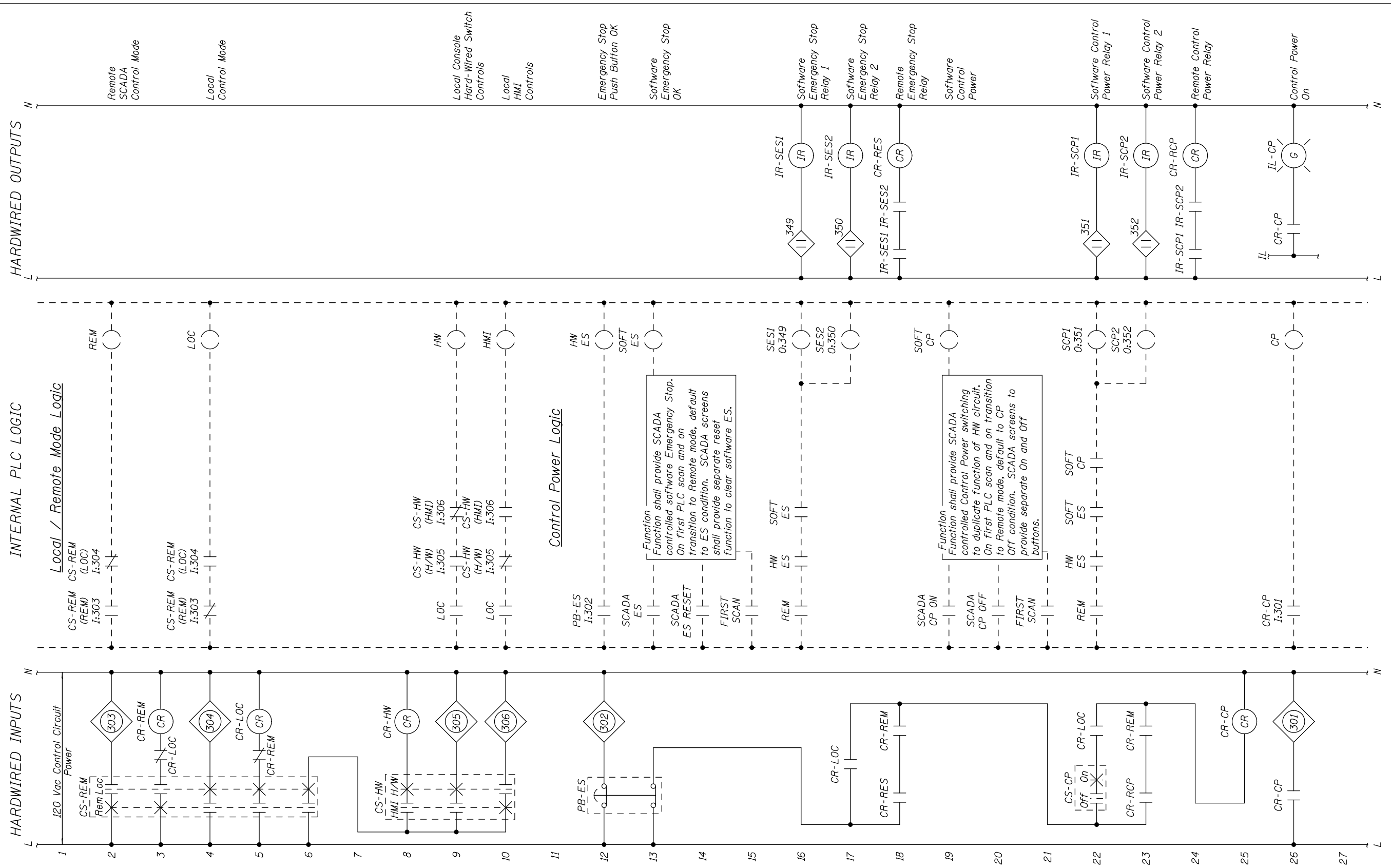

**NOTES:**

- Emergency stop Pushbuttons shall be illuminated type and shall be wired to illuminate when pressed.



USER NAME =	DESIGNED - R.I. PETERS	REVISED	---
	CHECKED - J.G. STRENKOSKI	REVISED	---
PLOT SCALE =	DRAWN - R.I. PETERS	REVISED	---
PLOT DATE =	CHECKED - J.G. STRENKOSKI	REVISED	---

**STATE OF ILLINOIS  
DEPARTMENT OF TRANSPORTATION**

**VARIOUS MOVABLE BRIDGES  
LOCAL CENTRALIZED CONTROL AND OPERATION  
BRANDON ROAD - CONTROL CIRCUIT - 5**

SHEET NO. 38 OF 93 SHEETS

BRANDON, Drawing 06-038			
F.A.P. RTE.	SECTION	COUNTY	TOTAL SHEETS
0341	2011-045-I	WILL	466
			SHEET NO. 363
CONTRACT NO. 60P55			
ILLINOIS FED. AID PROJECT			

HARDWIRED INPUTS

INTERNAL PLC LOGIC

HARDWIRED OUTPUTS

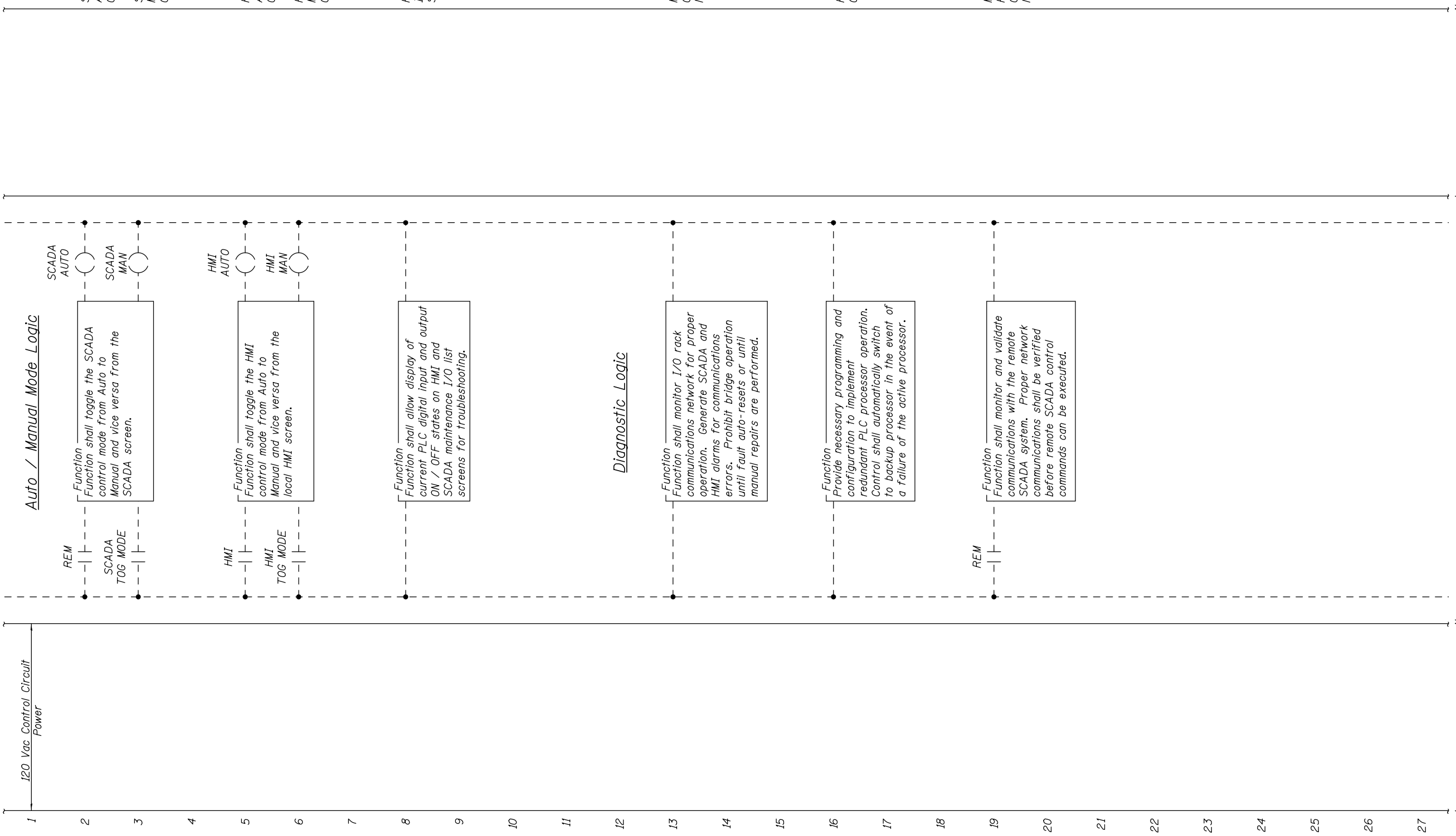

SCADA Automatic Control Mode  
SCADA Manual Control Mode

HMI Automatic Control Mode  
HMI Manual Control Mode

HMI and SCADA I/O Maintenance Screens

Monitor I/O Communications Network

Redundancy Control Function

Monitor Remote SCADA Communication Network

Auto / Manual Mode Logic

Function  
Function shall toggle the SCADA control mode from Auto to Manual and vice versa from the SCADA screen.

Function  
Function shall toggle the HMI control mode from Auto to Manual and vice versa from the local HMI screen.

Function  
Function shall allow display of current PLC digital input and output ON / OFF states on HMI and SCADA maintenance I/O list screens for troubleshooting.

Diagnostic Logic

Function  
Function shall monitor I/O rack communications network for proper operation. Generate SCADA and HMI alarms for communications errors. Prohibit bridge operation until fault auto-resets or until manual repairs are performed.

Function  
Provide necessary programming and configuration to implement redundant PLC processor operation. Control shall automatically switch to backup processor in the event of a failure of the active processor.

Function  
Function shall monitor and validate communications with the remote SCADA system. Proper network communications shall be verified before remote SCADA control commands can be executed.



USER NAME =	DESIGNED - R.I. PETERS	REVISED	---
	CHECKED - J.G. STRENKOSKI	REVISED	---
PLOT SCALE =	DRAWN - R.I. PETERS	REVISED	---
PLOT DATE =	CHECKED - J.G. STRENKOSKI	REVISED	---

STATE OF ILLINOIS  
DEPARTMENT OF TRANSPORTATION

VARIOUS MOVABLE BRIDGES  
LOCAL CENTRALIZED CONTROL AND OPERATION  
BRANDON ROAD - CONTROL CIRCUIT - 6

SHEET NO. 39 OF 93 SHEETS

BRANDON, Drawing 06-039			
F.A.P. RTE.	SECTION	COUNTY	TOTAL SHEETS
0341	2011-045-I	WILL	466
			SHEET NO. 364
CONTRACT NO. 60P55			
ILLINOIS FED. AID PROJECT			



HARDWIRED INPUTS

INTERNAL PLC LOGIC

HARDWIRED OUTPUTS

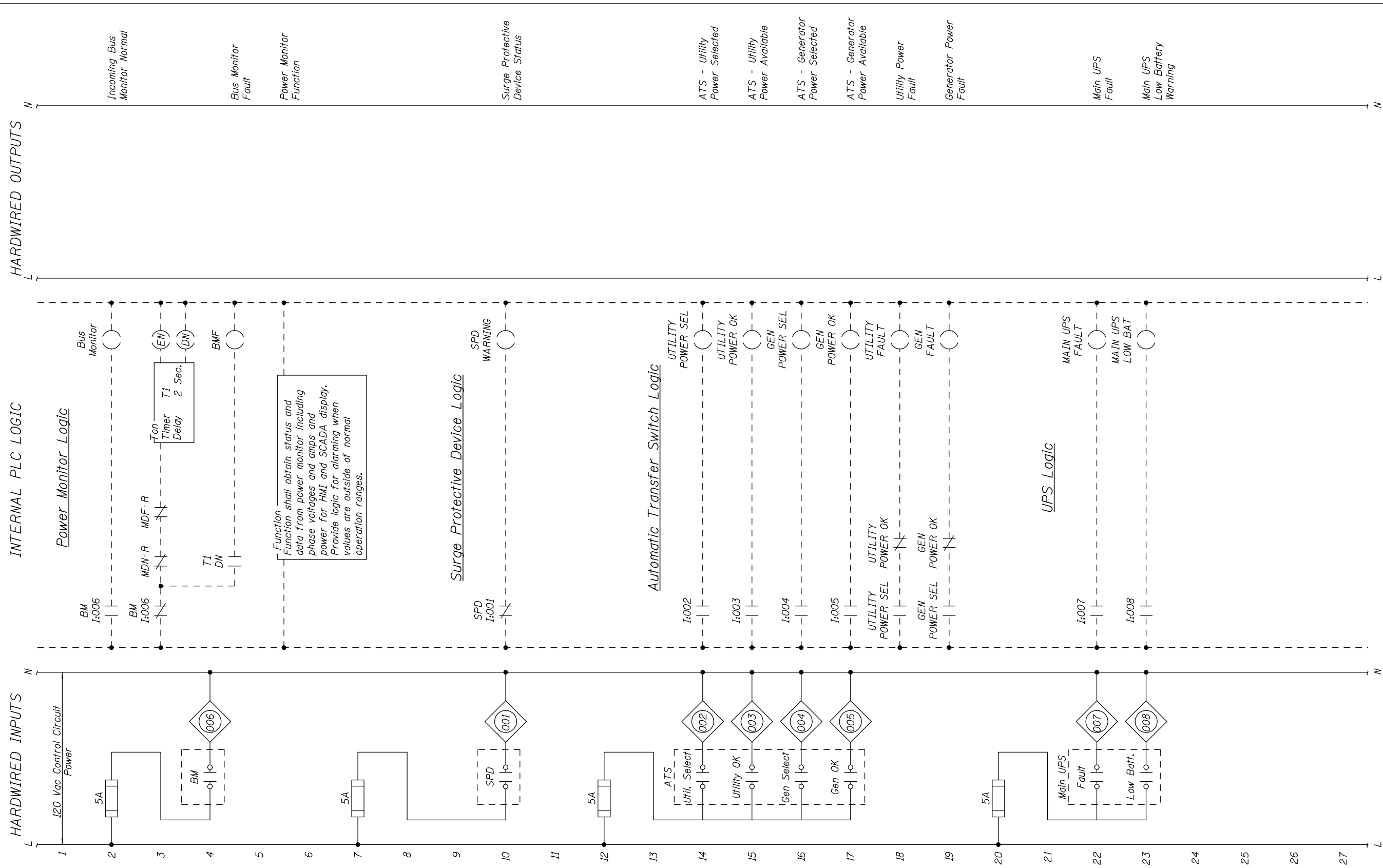

**NOTES:**

1. Provide additional timers as required to condition PLC inputs for sensing devices.



USER NAME =	DESIGNED - R.I. PETERS	REVISED	---
	CHECKED - J.G. STRENKOSKI	REVISED	---
PLOT SCALE =	DRAWN - R.I. PETERS	REVISED	---
PLOT DATE =	CHECKED - J.G. STRENKOSKI	REVISED	---

**STATE OF ILLINOIS  
DEPARTMENT OF TRANSPORTATION**

**VARIOUS MOVABLE BRIDGES  
LOCAL CENTRALIZED CONTROL AND OPERATION  
BRANDON ROAD - CONTROL CIRCUIT - 7**

SHEET NO. 40 OF 93 SHEETS

BRANDON, Drawing 06-040			
F.A.P. RTE.	SECTION	COUNTY	TOTAL SHEETS
0341	2011-045-I	WILL	466
			SHEET NO. 365
CONTRACT NO. 60P55			
ILLINOIS FED. AID PROJECT			

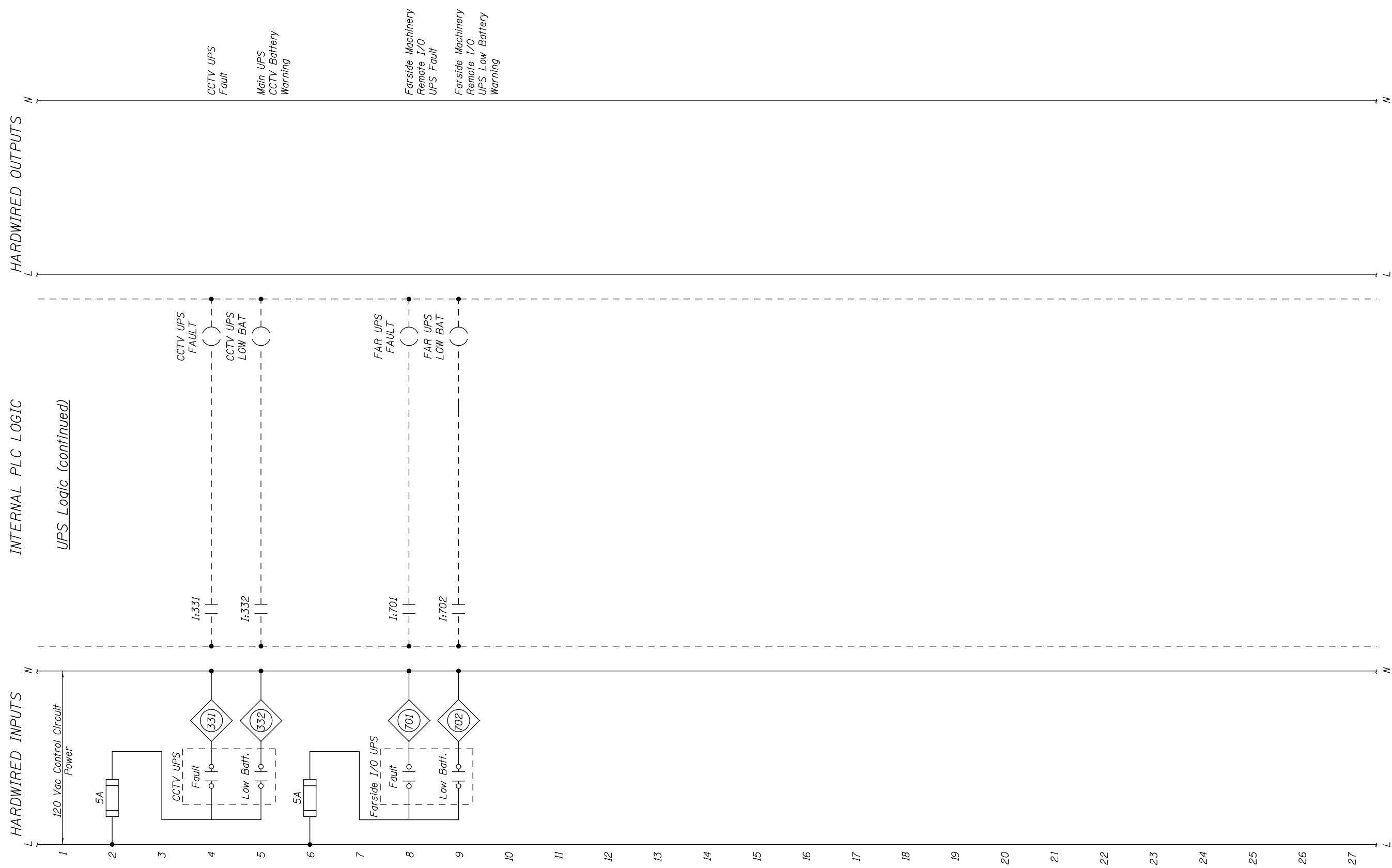

**NOTES:**

1. Provide additional timers as required to condition PLC inputs for sensing devices.



USER NAME =	DESIGNED - R.I. PETERS	REVISED	---
	CHECKED - J.G. STRENKOSKI	REVISED	---
PLOT SCALE =	DRAWN - R.I. PETERS	REVISED	---
PLOT DATE =	CHECKED - J.G. STRENKOSKI	REVISED	---

**STATE OF ILLINOIS  
DEPARTMENT OF TRANSPORTATION**

**VARIOUS MOVABLE BRIDGES  
LOCAL CENTRALIZED CONTROL AND OPERATION  
BRANDON ROAD - CONTROL CIRCUIT - 8**

SHEET NO. 41 OF 93 SHEETS

BRANDON, Drawing 06-041	
F.A.P. RTE.	SECTION
0341	2011-045-I
COUNTY	WILL
TOTAL SHEETS	466
SHEET NO.	366
CONTRACT NO. 60P55	
ILLINOIS FED. AID PROJECT	

HARDWIRED INPUTS

INTERNAL PLC LOGIC

HARDWIRED OUTPUTS

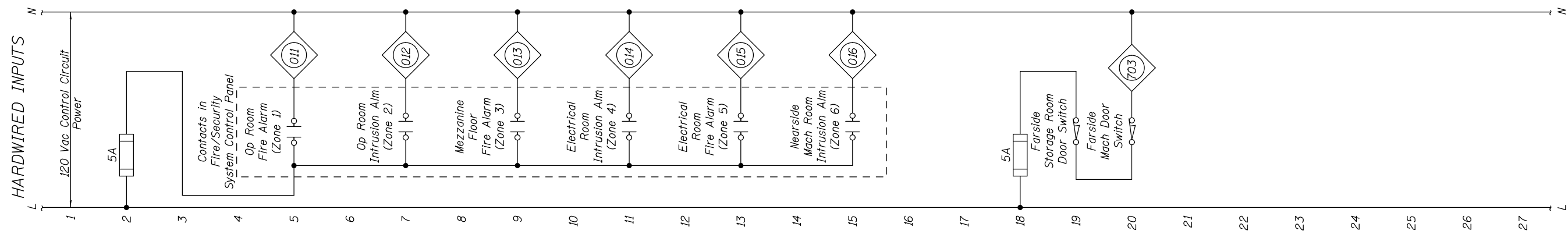

Security and Fire Alarm Logic

Function shall generate alarms to notify remote operator of bridge operator house and machinery area fire/security alarms. Condition signals as required with short duration timers to prevent false alarms.

Function shall generate individual alarms to notify remote operator of machinery area door openings.

NOTES:

1. Provide additional timers as required to condition PLC inputs.
2. Where possible, switches and sensors shall be wired to provide fail-safe operation.



USER NAME =	DESIGNED - R.I. PETERS	REVISED	---
	CHECKED - J.G. STRENKOSKI	REVISED	---
PLOT SCALE =	DRAWN - R.I. PETERS	REVISED	---
PLOT DATE =	CHECKED - J.G. STRENKOSKI	REVISED	---

STATE OF ILLINOIS  
DEPARTMENT OF TRANSPORTATION

VARIOUS MOVABLE BRIDGES  
LOCAL CENTRALIZED CONTROL AND OPERATION  
BRANDON ROAD - CONTROL CIRCUIT - 9

SHEET NO. 42 OF 93 SHEETS

BRANDON, Drawing 06-042			
F.A.P. RTE.	SECTION	COUNTY	TOTAL SHEETS
0341	2011-045-I	WILL	466
			SHEET NO. 367
CONTRACT NO. 60P55			
ILLINOIS FED. AID PROJECT			

Traffic Signal Hard-Wired Logic

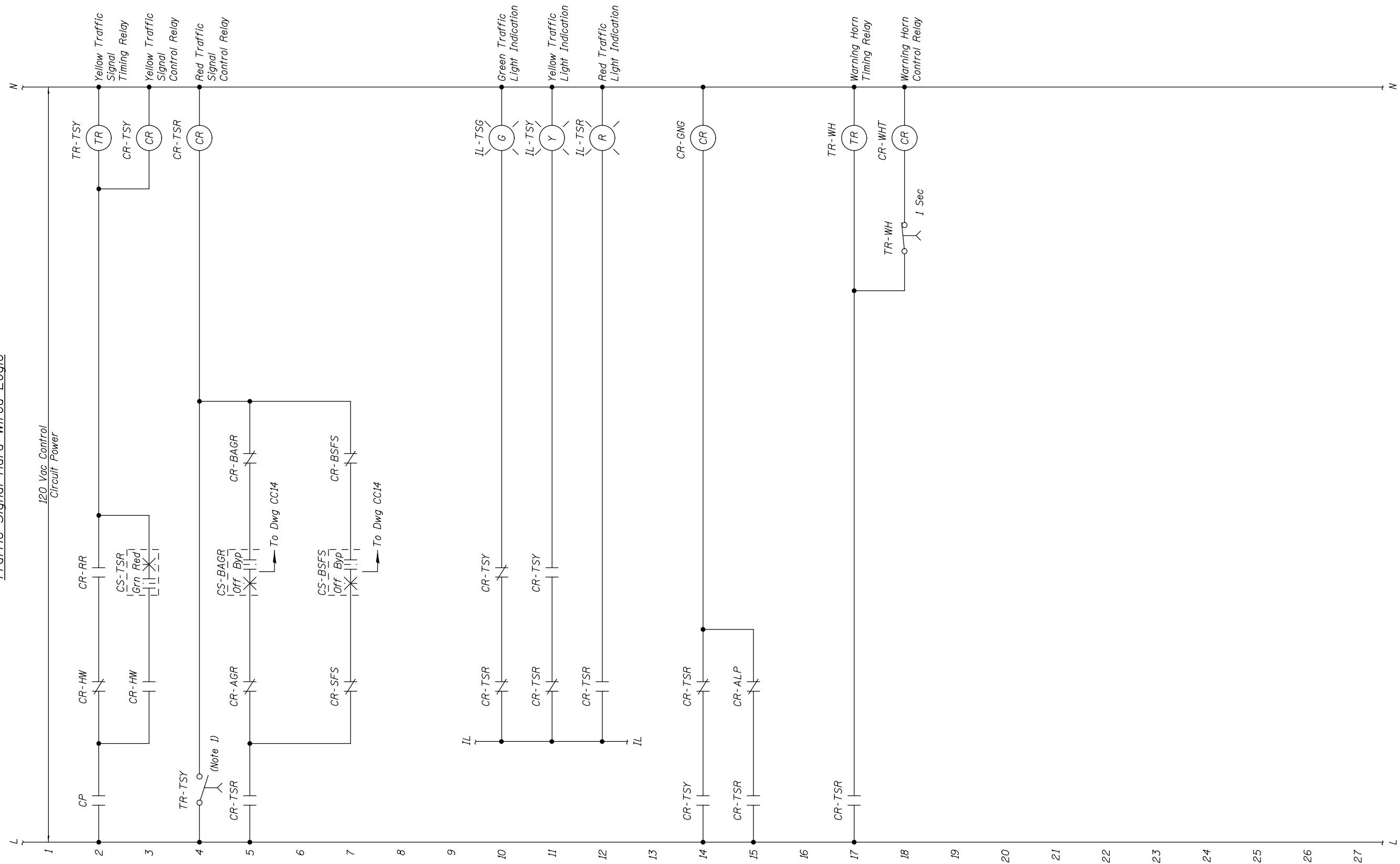

NOTES:

- Set timer preset according to IDOT requirements for yellow light cycle time.



USER NAME =	DESIGNED - R.I. PETERS	REVISED	---
	CHECKED - J.G. STRENKOSKI	REVISED	---
PLOT SCALE =	DRAWN - R.I. PETERS	REVISED	---
PLOT DATE =	CHECKED - J.G. STRENKOSKI	REVISED	---

STATE OF ILLINOIS  
DEPARTMENT OF TRANSPORTATION

VARIOUS MOVABLE BRIDGES  
LOCAL CENTRALIZED CONTROL AND OPERATION  
BRANDON ROAD - CONTROL CIRCUIT - 10

BRANDON, Drawing 06-043			
F.A.P. RTE.	SECTION	COUNTY	TOTAL SHEETS
0341	2011-045-I	WILL	466
			SHEET NO. 368
CONTRACT NO. 60P55			

Traffic Signal Power

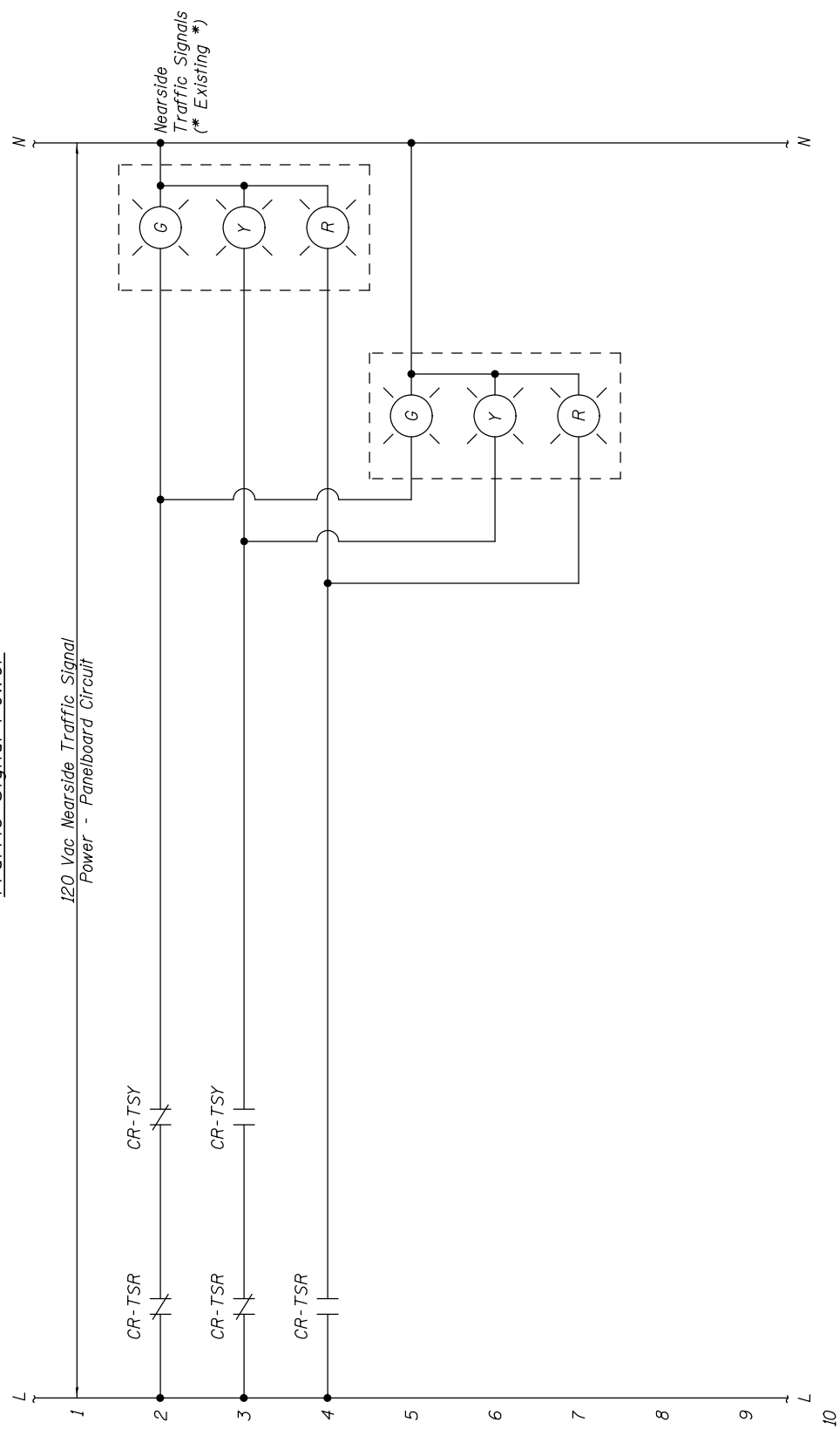

Traffic Signal Power

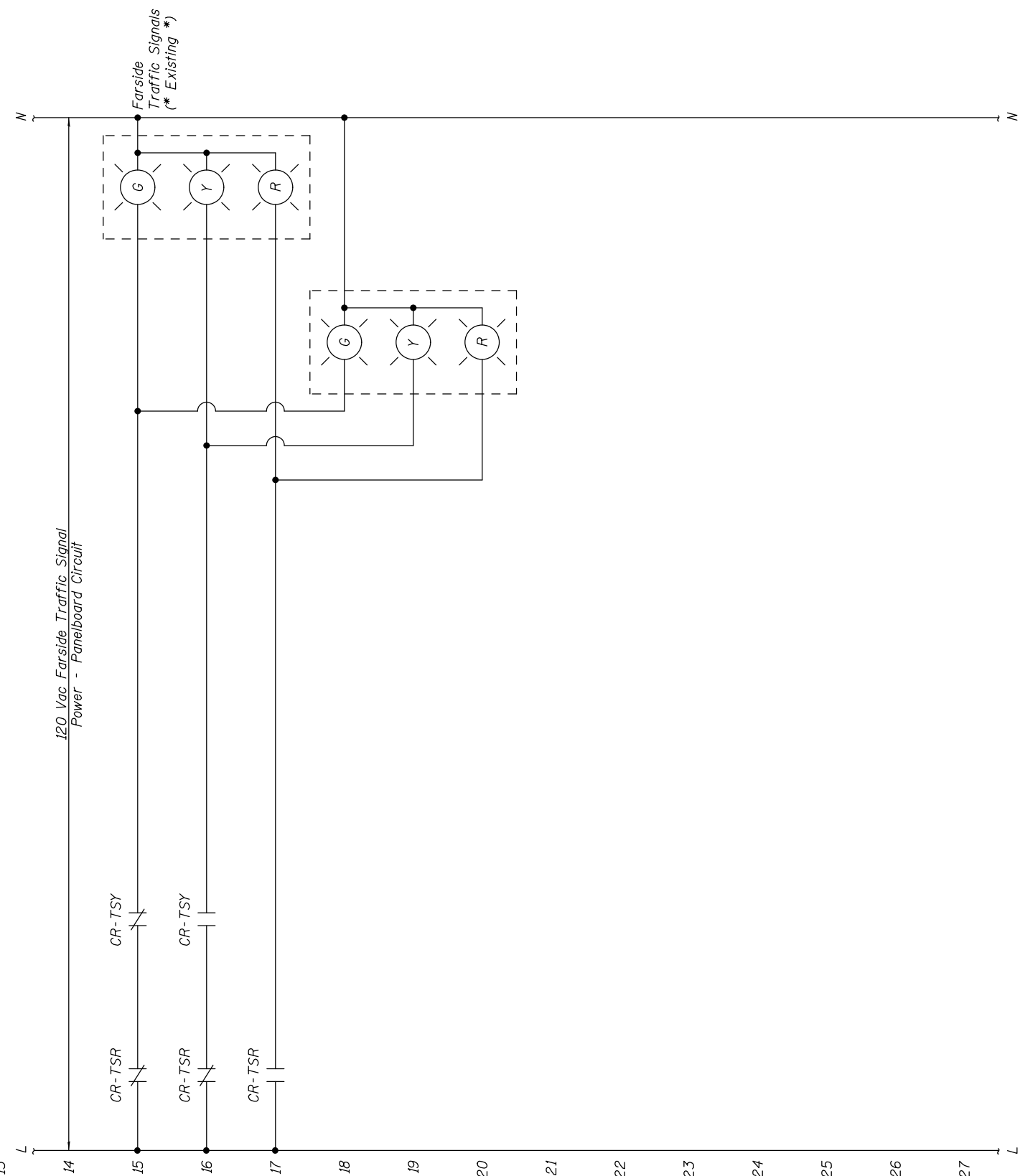

USER NAME =	DESIGNED - R.I. PETERS	REVISED	---
	CHECKED - J.G. STRENKOSKI	REVISED	---
PLOT SCALE =	DRAWN - R.I. PETERS	REVISED	---
PLOT DATE =	CHECKED - J.G. STRENKOSKI	REVISED	---

STATE OF ILLINOIS  
DEPARTMENT OF TRANSPORTATION

VARIOUS MOVABLE BRIDGES  
LOCAL CENTRALIZED CONTROL AND OPERATION  
BRANDON ROAD - CONTROL CIRCUIT - 11

SHEET NO. 44 OF 93 SHEETS

F.A.P. RTE.	SECTION	COUNTY	TOTAL SHEETS	SHEET NO.
0341	2011-045-I	WILL	466	369
CONTRACT NO. 60P55				

ILLINOIS FED. AID PROJECT

BRANDON, Drawing 06-044

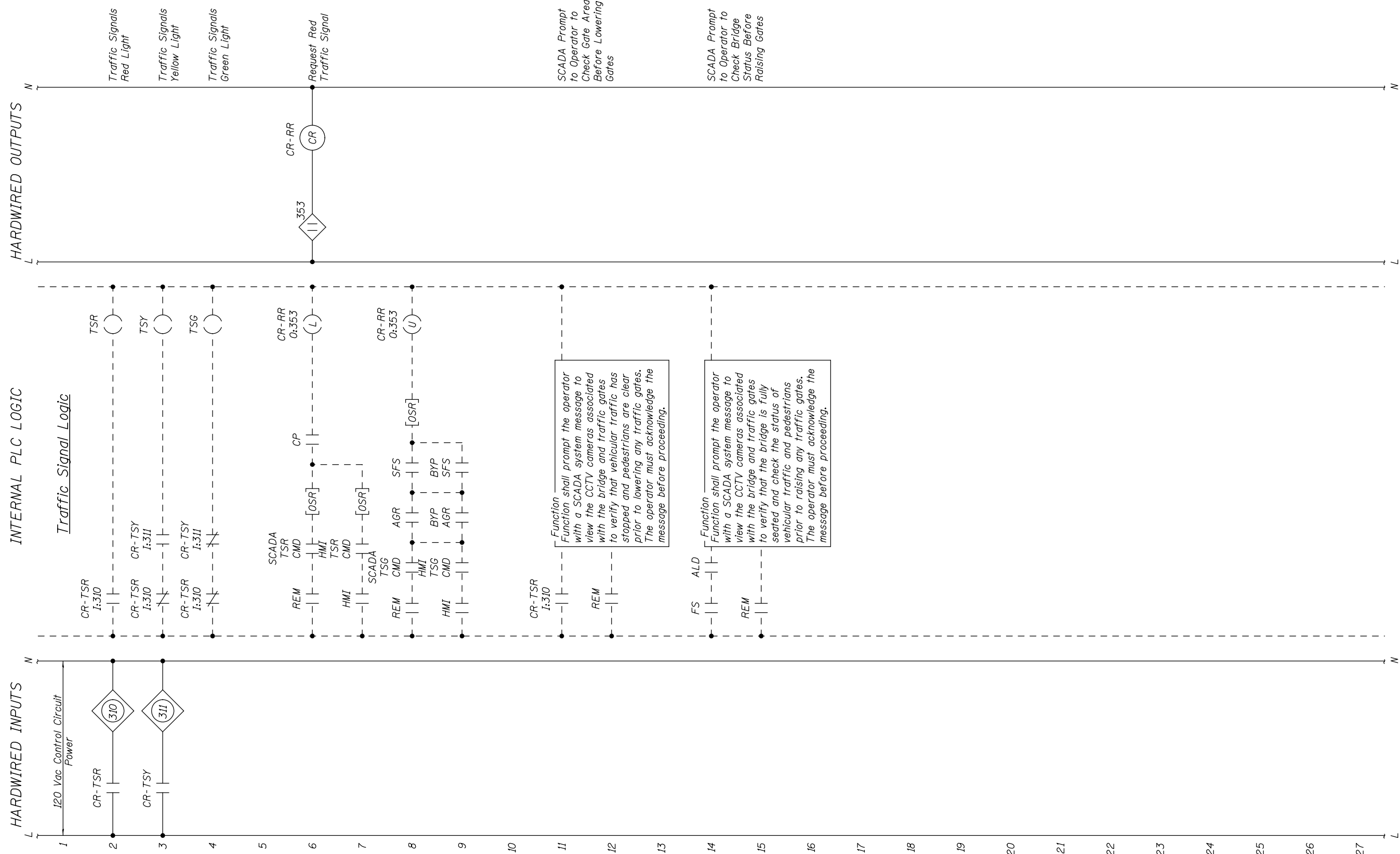

HARDWIRED INPUTS

HARDWIRED OUTPUTS



USER NAME =	DESIGNED - R.I. PETERS	REVISED	___
	CHECKED - J.G. STRENKOSKI	REVISED	___
PLOT SCALE =	DRAWN - R.I. PETERS	REVISED	___
PLOT DATE =	CHECKED - J.G. STRENKOSKI	REVISED	___

STATE OF ILLINOIS  
DEPARTMENT OF TRANSPORTATION

VARIOUS MOVABLE BRIDGES  
LOCAL CENTRALIZED CONTROL AND OPERATION  
BRANDON ROAD - CONTROL CIRCUIT - 12

F.A.P. RTE.	SECTION	COUNTY	TOTAL SHEETS	SHEET NO.
0341	2011-045-I	WILL	466	370
CONTRACT NO. 60P55				

SHEET NO. 45 OF 93 SHEETS

ILLINOIS FED. AID PROJECT

BRANDON, Drawing 06-045

*Traffic Gate Warning Lights and Gongs Power*

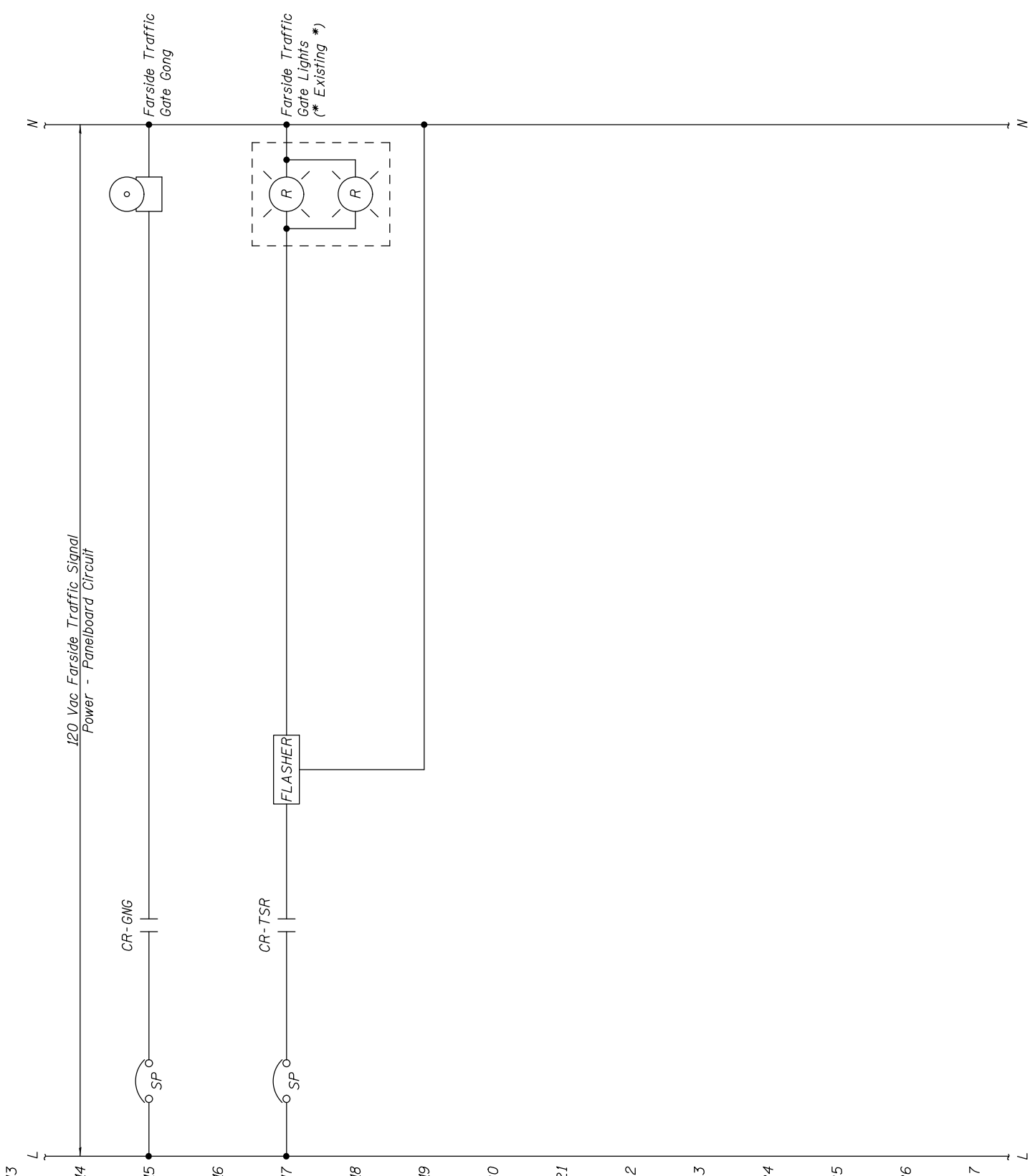
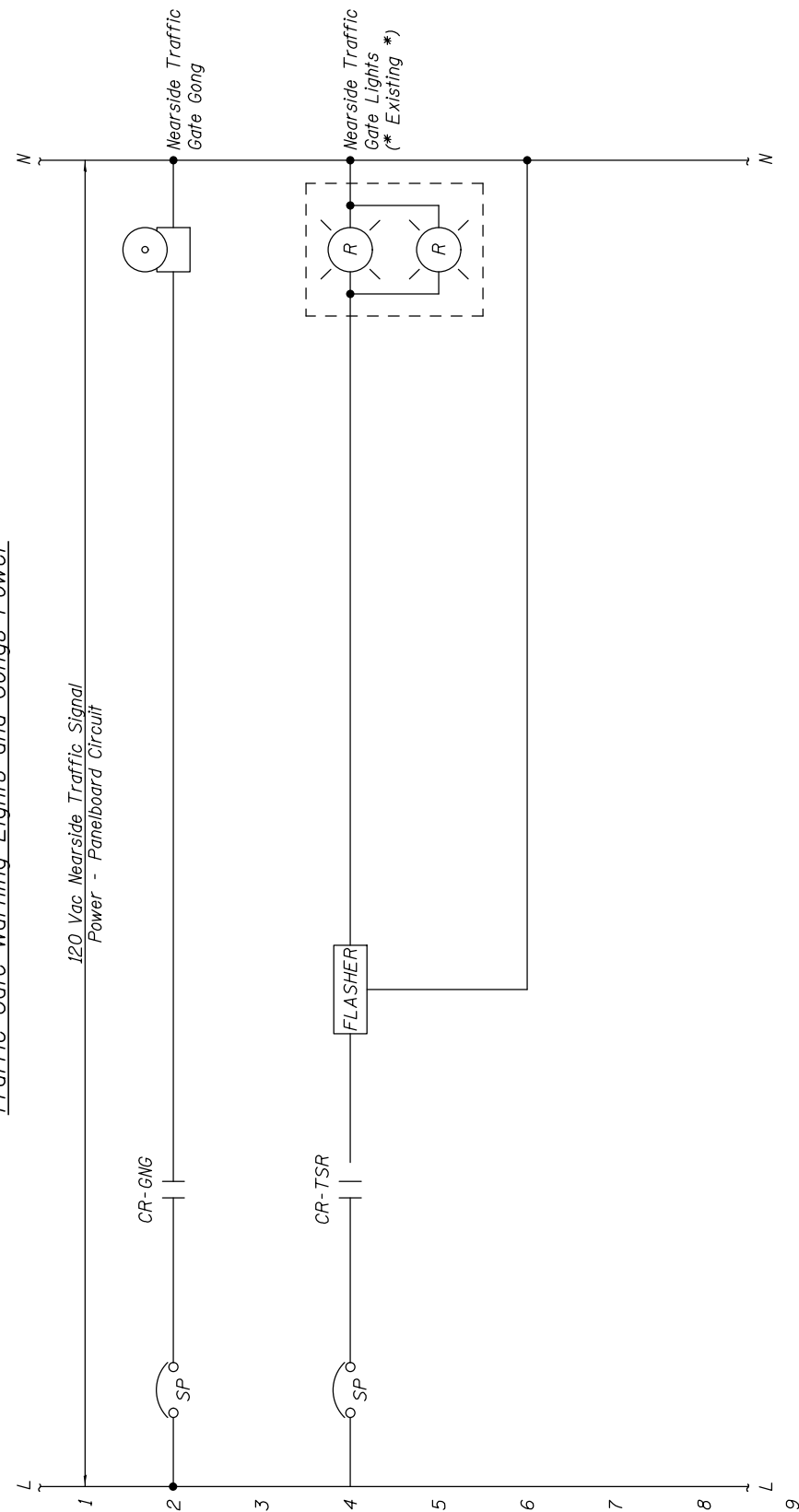

USER NAME =	DESIGNED - R.I. PETERS	REVISED	---
	CHECKED - J.G. STRENKOSKI	REVISED	---
PLOT SCALE =	DRAWN - R.I. PETERS	REVISED	---
PLOT DATE =	CHECKED - J.G. STRENKOSKI	REVISED	---

STATE OF ILLINOIS  
DEPARTMENT OF TRANSPORTATION

VARIOUS MOVABLE BRIDGES  
LOCAL CENTRALIZED CONTROL AND OPERATION  
BRANDON ROAD - CONTROL CIRCUIT - 13

SHEET NO. 46 OF 93 SHEETS

F.A.P. RTE.	SECTION	COUNTY	TOTAL SHEETS	SHEET NO.
0341	2011-045-I	WILL	466	371
CONTRACT NO. 60P55				
ILLINOIS FED. AID PROJECT				

BRANDON, Drawing 06-046

HARDWIRED INPUTS

INTERNAL PLC LOGIC

HARDWIRED OUTPUTS

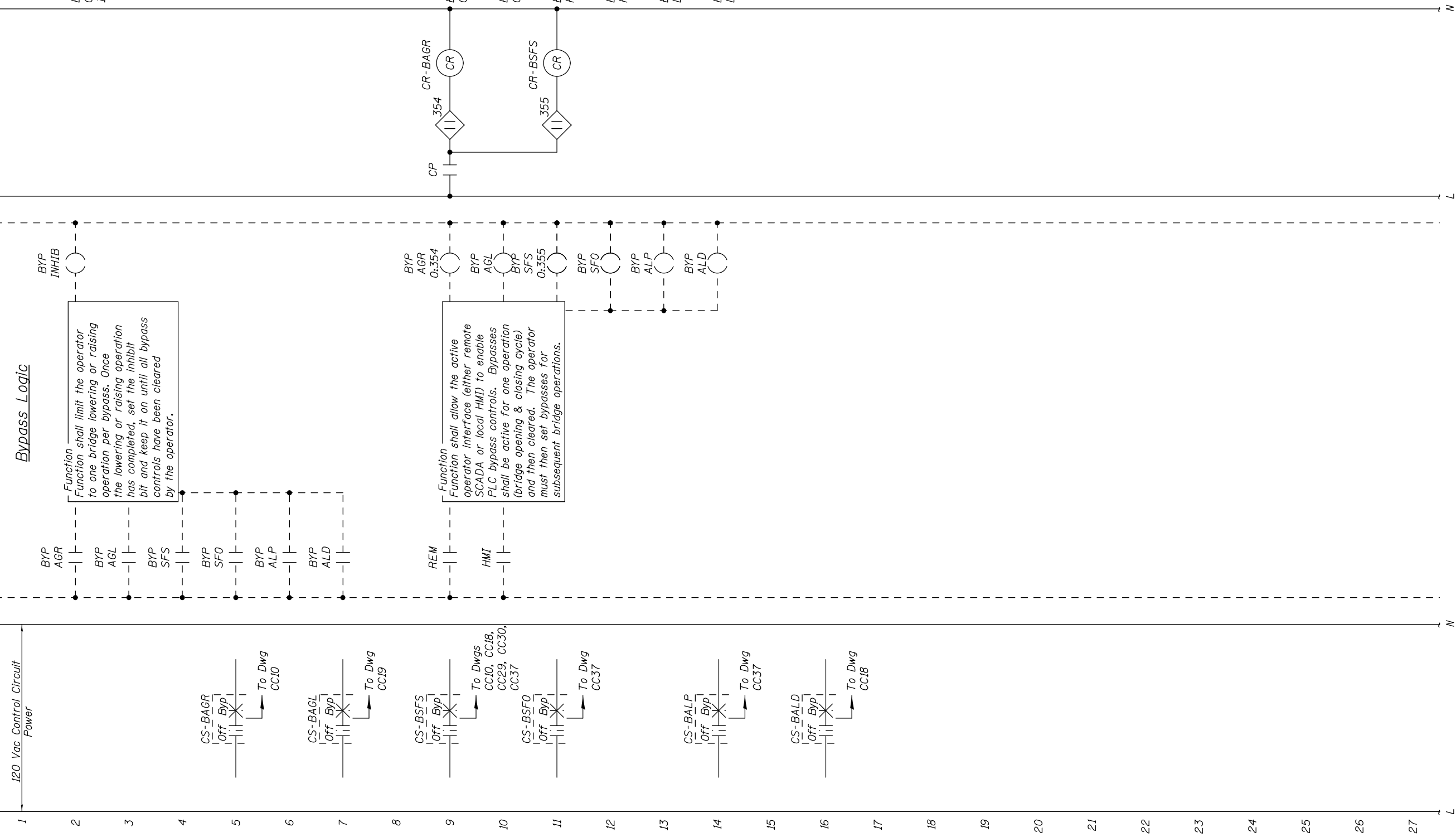

**BYPASS LOGIC**

Function  
 This function shall limit the operator to one bridge lowering or raising operation per bypass. Once the lowering or raising operation has completed, set the inhibit bit and keep it on until all bypass controls have been cleared by the operator.

Function  
 This function shall allow the active operator interface (either remote SCADA or local HMI) to enable PLC bypass controls. Bypasses shall be active for one operation (bridge opening & closing cycle) and then cleared. The operator must then set bypasses for subsequent bridge operations.



USER NAME =	DESIGNED - R.I. PETERS	REVISED
	CHECKED - J.G. STRENKOSKI	REVISED
PLOT SCALE =	DRAWN - R.I. PETERS	REVISED
PLOT DATE =	CHECKED - J.G. STRENKOSKI	REVISED

STATE OF ILLINOIS  
 DEPARTMENT OF TRANSPORTATION

VARIOUS MOVABLE BRIDGES  
 LOCAL CENTRALIZED CONTROL AND OPERATION  
 BRANDON ROAD - CONTROL CIRCUIT - 14

SHEET NO. 47 OF 93 SHEETS

BRANDON, Drawing 06-047			
F.A.P. RTE.	SECTION	COUNTY	TOTAL SHEETS
0341	2011-045-I	WILL	466
			SHEET NO. 372
CONTRACT NO. 60P55			
ILLINOIS FED. AID PROJECT			



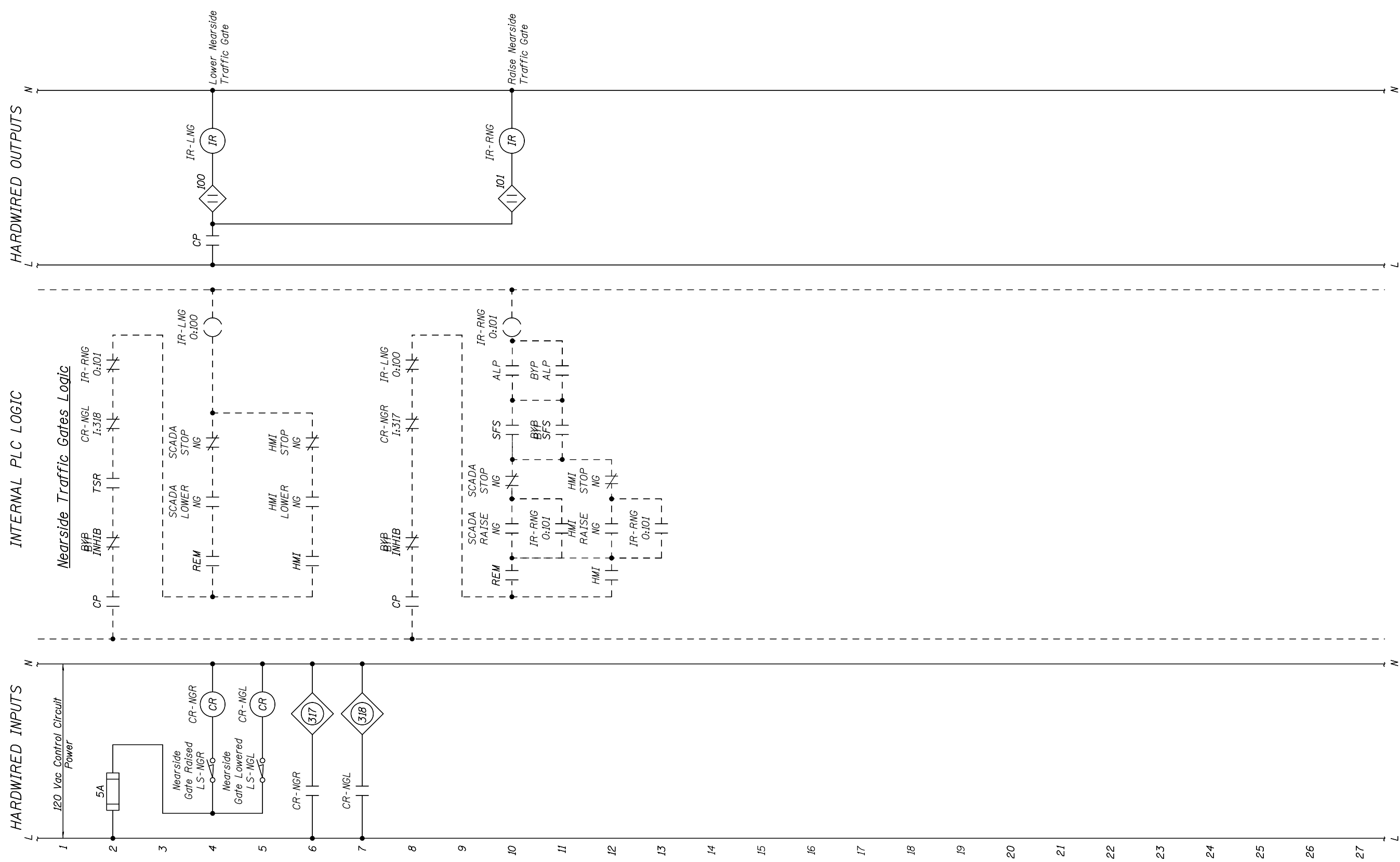

**NOTES:**

1. Provide a "Group Gate Raise" button on the HMI and SCADA screens and required PLC logic to raise both gates at the same time.



USER NAME =	DESIGNED - R.I. PETERS	REVISED -
	CHECKED - J.G. STRENKOSKI	REVISED -
PLOT SCALE =	DRAWN - R.I. PETERS	REVISED -
PLOT DATE =	CHECKED - J.G. STRENKOSKI	REVISED -

**STATE OF ILLINOIS  
DEPARTMENT OF TRANSPORTATION**

**VARIOUS MOVABLE BRIDGES  
LOCAL CENTRALIZED CONTROL AND OPERATION  
BRANDON ROAD - CONTROL CIRCUIT - 15**

BRANDON, Drawing 06-048			
F.A.P. RTE.	SECTION	COUNTY	TOTAL SHEETS
0341	2011-045-I	WILL	466
			SHEET NO. 373
CONTRACT NO. 60P55			

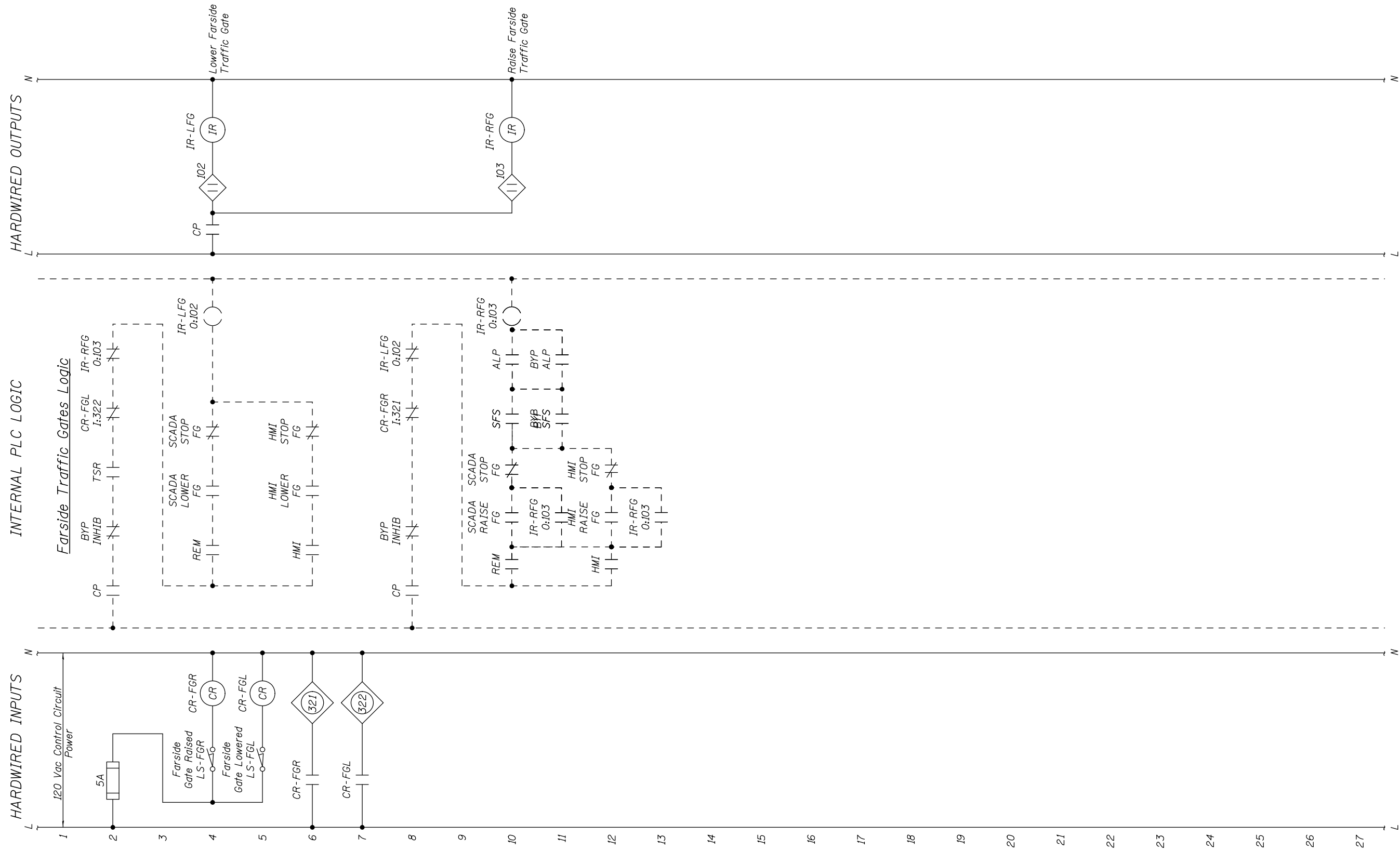

USER NAME =	DESIGNED - R.I. PETERS	REVISED	---
	CHECKED - J.G. STRENKOSKI	REVISED	---
PLOT SCALE =	DRAWN - R.I. PETERS	REVISED	---
PLOT DATE =	CHECKED - J.G. STRENKOSKI	REVISED	---

**STATE OF ILLINOIS  
DEPARTMENT OF TRANSPORTATION**

**VARIOUS MOVABLE BRIDGES  
LOCAL CENTRALIZED CONTROL AND OPERATION  
BRANDON ROAD - CONTROL CIRCUIT - 16**

SHEET NO. 49 OF 93 SHEETS

F.A.P. RTE.		SECTION	COUNTY	TOTAL SHEETS	SHEET NO.
0341		2011-045-I	WILL	466	374
CONTRACT NO. 60P55					

BRANDON, Drawing 06-049

ILLINOIS FED. AID PROJECT

HARDWIRED INPUTS

INTERNAL PLC LOGIC

HARDWIRED OUTPUTS

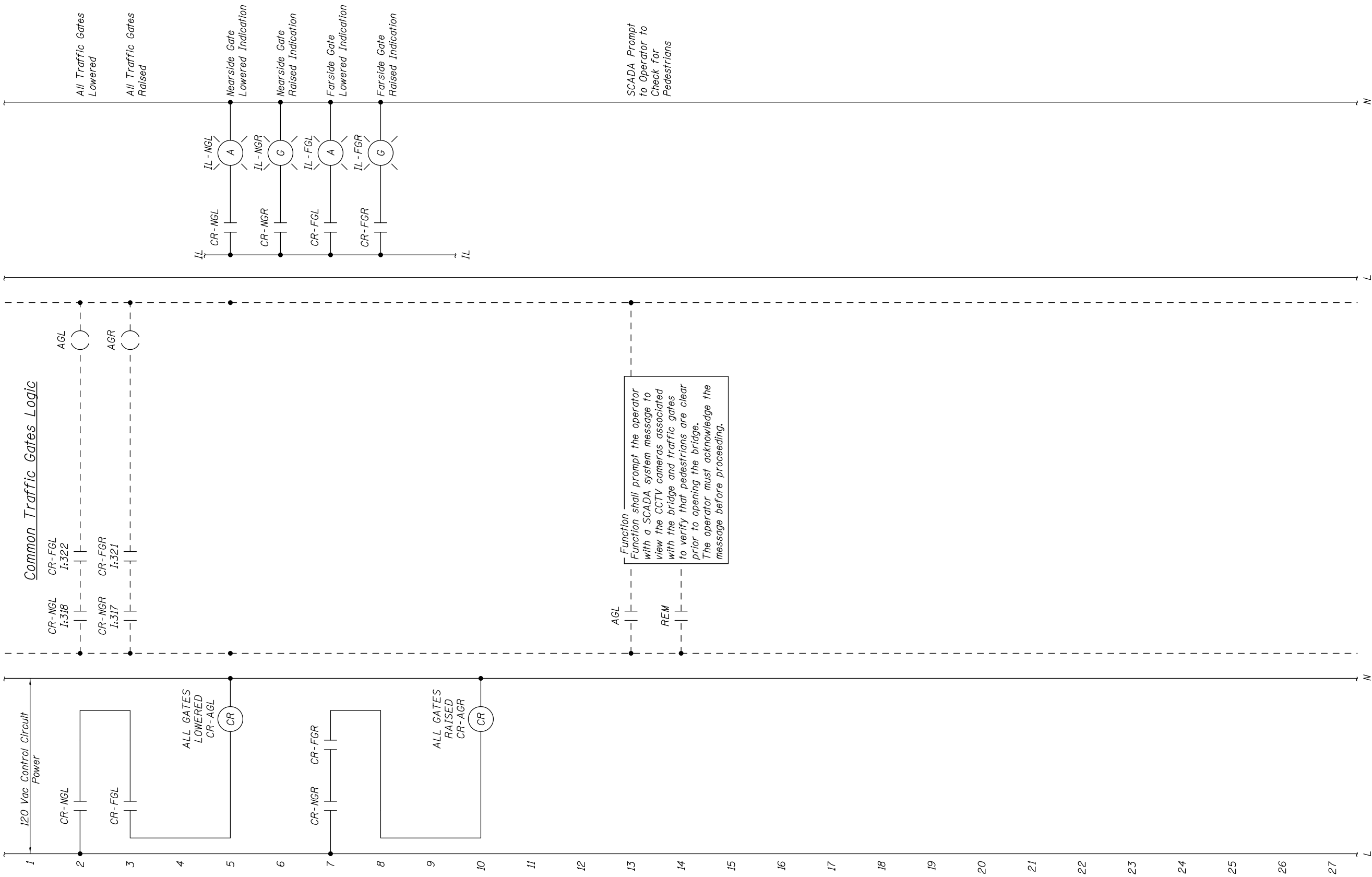

USER NAME =	DESIGNED - R.I. PETERS	REVISED	---
	CHECKED - J.G. STRENKOSKI	REVISED	---
PLOT SCALE =	DRAWN - R.I. PETERS	REVISED	---
PLOT DATE =	CHECKED - J.G. STRENKOSKI	REVISED	---

STATE OF ILLINOIS  
DEPARTMENT OF TRANSPORTATION

VARIOUS MOVABLE BRIDGES  
LOCAL CENTRALIZED CONTROL AND OPERATION  
BRANDON ROAD - CONTROL CIRCUIT - 17

SHEET NO. 50 OF 93 SHEETS

BRANDON, Drawing 06-050			
F.A.P. RTE.	SECTION	COUNTY	TOTAL SHEETS
0341	2011-045-I	WILL	466
			SHEET NO. 375
CONTRACT NO. 60P55			
ILLINOIS FED. AID PROJECT			



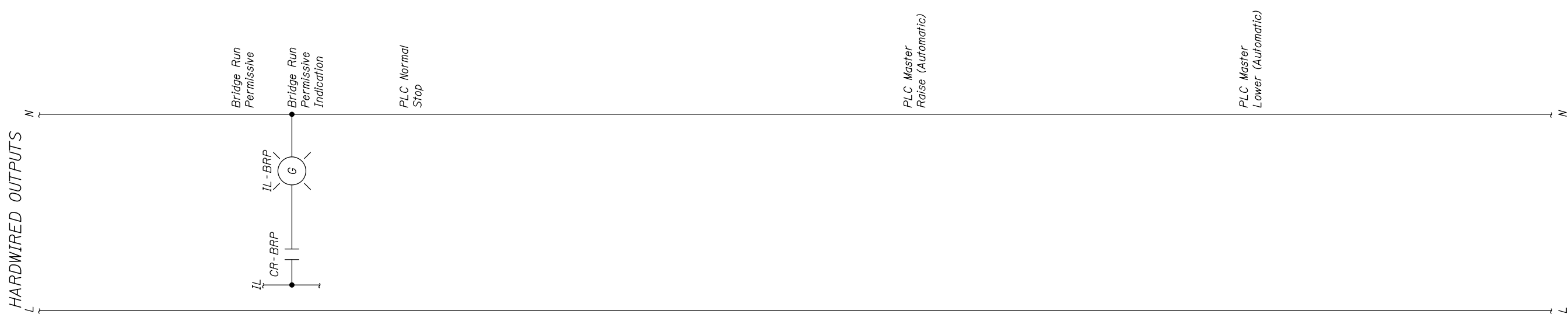
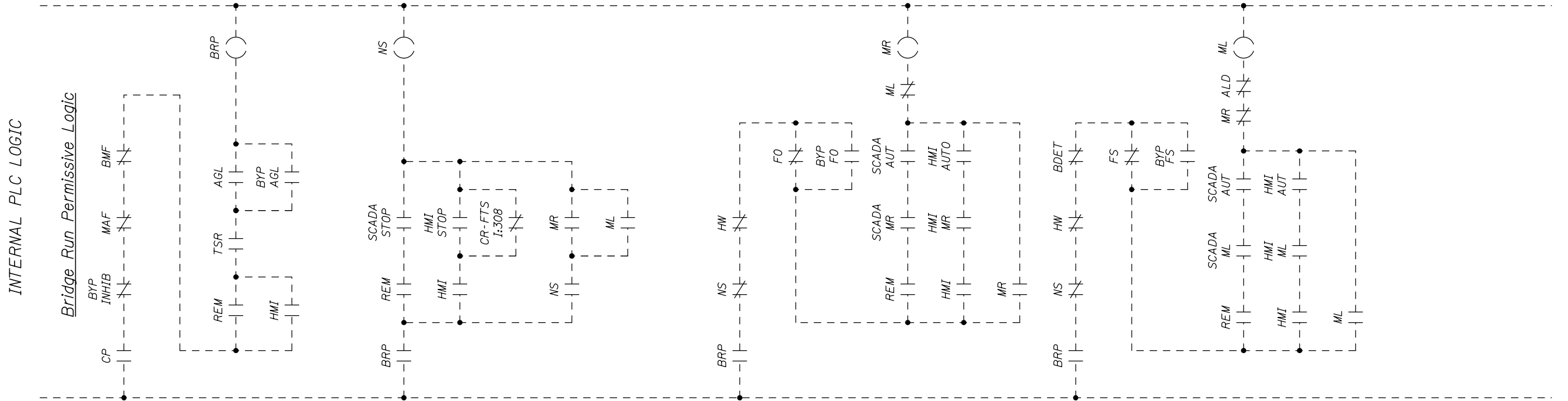
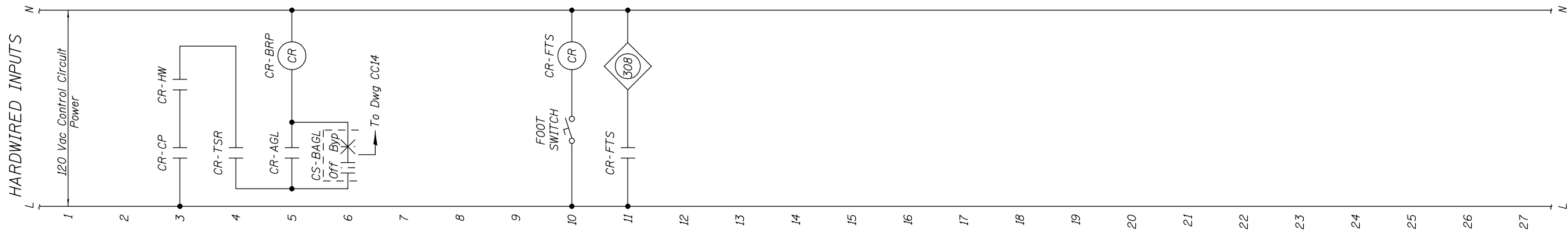

USER NAME =	DESIGNED - R.I. PETERS	REVISED	---
	CHECKED - J.G. STRENKOSKI	REVISED	---
PLOT SCALE =	DRAWN - R.I. PETERS	REVISED	---
PLOT DATE =	CHECKED - J.G. STRENKOSKI	REVISED	---

**STATE OF ILLINOIS  
DEPARTMENT OF TRANSPORTATION**

**VARIOUS MOVABLE BRIDGES  
LOCAL CENTRALIZED CONTROL AND OPERATION  
BRANDON ROAD - CONTROL CIRCUIT - 19**

F.A.P. RTE.	SECTION	COUNTY	TOTAL SHEETS	SHEET NO.
0341	2011-045-I	WILL	466	377
CONTRACT NO. 60P55				
ILLINOIS FED. AID PROJECT				

BRANDON, Drawing 06-052

SHEET NO. 52 OF 93 SHEETS

HARDWIRED INPUTS

INTERNAL PLC LOGIC

HARDWIRED OUTPUTS

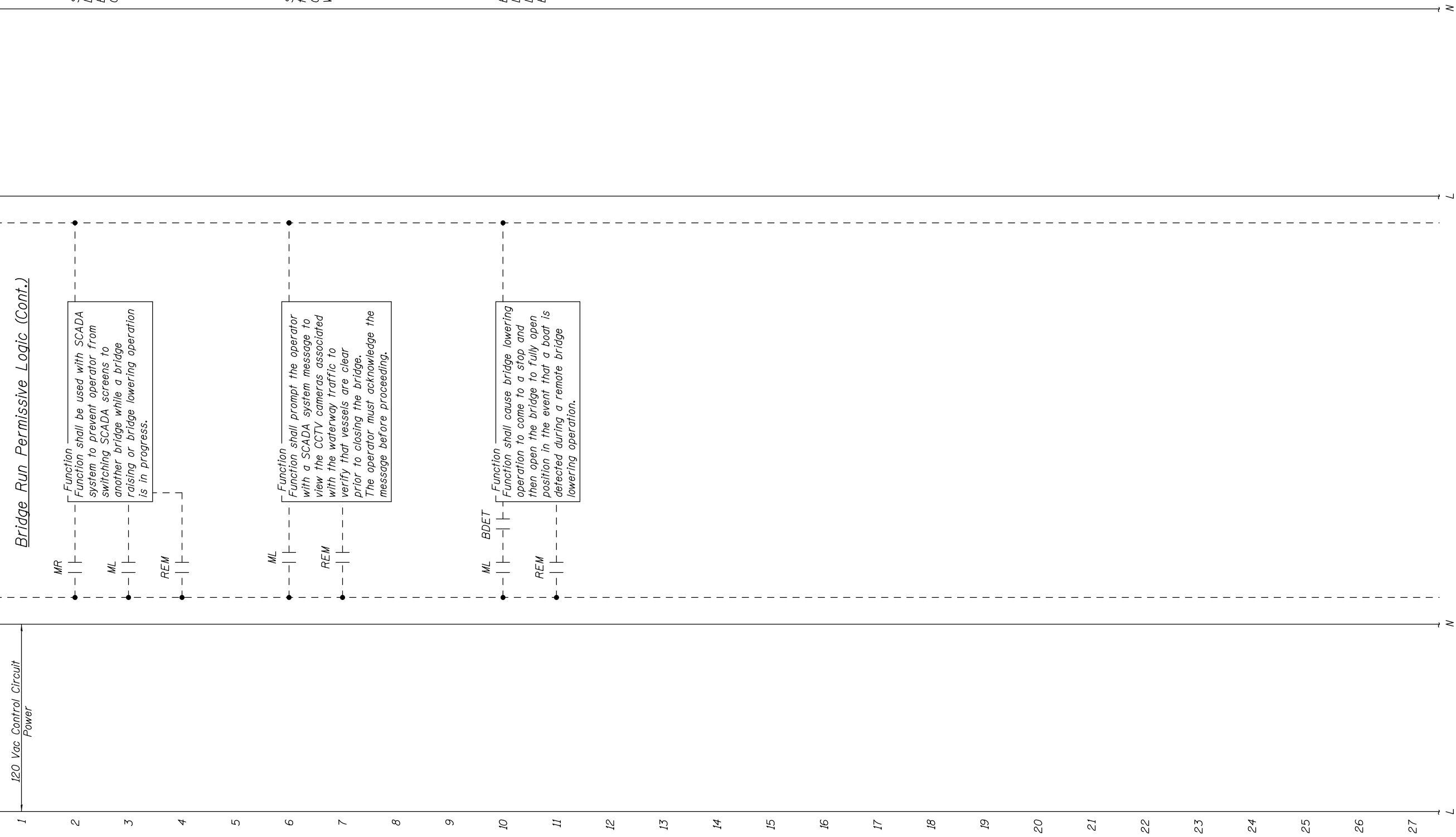

SCADA System Lock to This Bridge During Operation

SCADA Prompt to Operator to Check for Waterway Traffic

Boat Detected During Remote Lowering - Open Bridge Immediately



USER NAME =	DESIGNED - R.I. PETERS	REVISED	---
	CHECKED - J.G. STRENKOSKI	REVISED	---
PLOT SCALE =	DRAWN - R.I. PETERS	REVISED	---
PLOT DATE =	CHECKED - J.G. STRENKOSKI	REVISED	---

STATE OF ILLINOIS  
DEPARTMENT OF TRANSPORTATION

VARIOUS MOVABLE BRIDGES  
LOCAL CENTRALIZED CONTROL AND OPERATION  
BRANDON ROAD - CONTROL CIRCUIT - 20

SHEET NO. 53 OF 93 SHEETS

F.A.P. RTE.		SECTION	COUNTY	TOTAL SHEETS	SHEET NO.
0341		2011-045-I	WILL	466	378
CONTRACT NO. 60P55					

BRANDON, Drawing 06-053

ILLINOIS FED. AID PROJECT

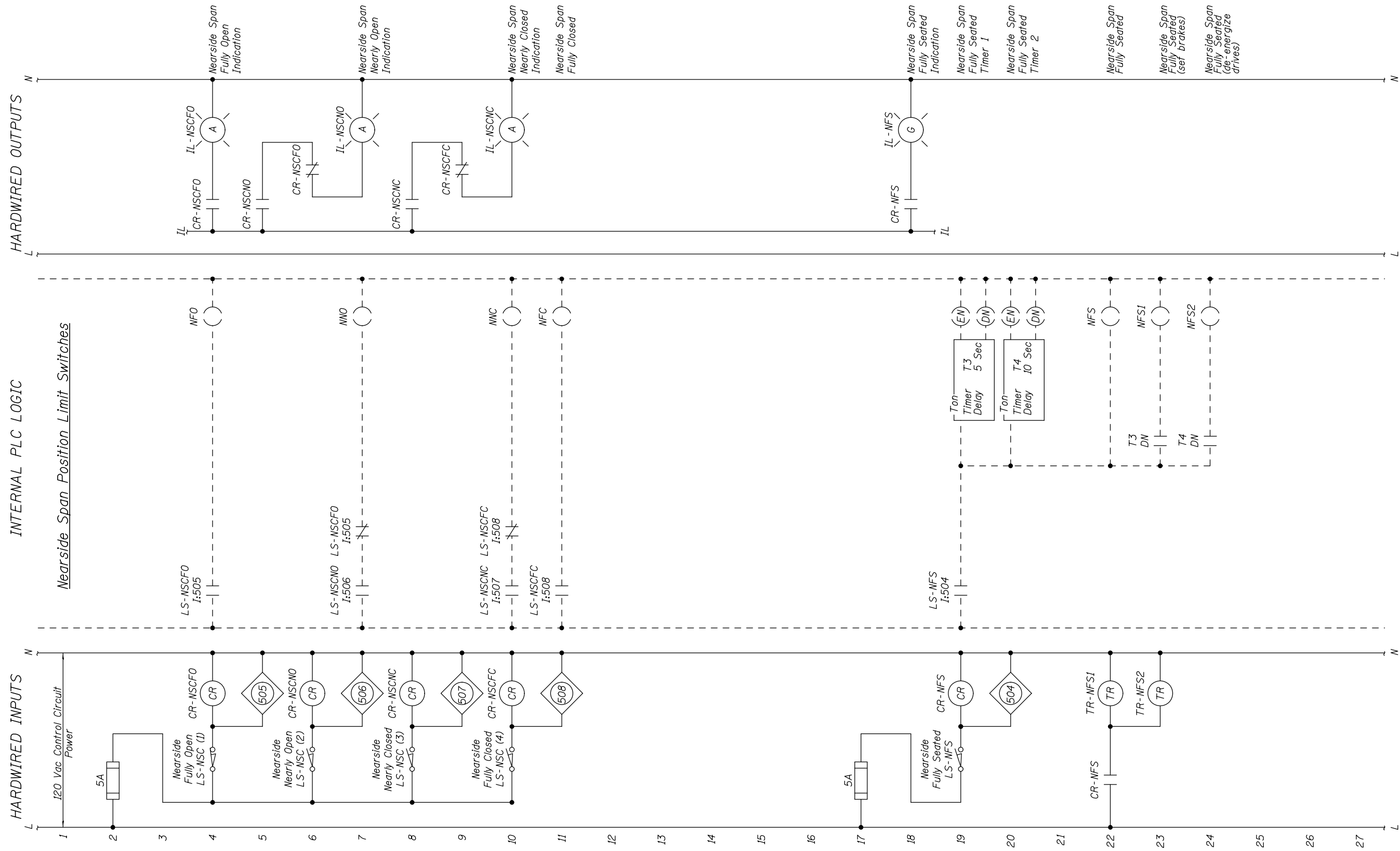

**NOTES:**  
 1. Provide additional de-bounce timers as required to condition PLC inputs for sensing devices.



USER NAME =	DESIGNED - R.I. PETERS	REVISED
	CHECKED - J.G. STRENKOSKI	REVISED
PLOT SCALE =	DRAWN - R.I. PETERS	REVISED
PLOT DATE =	CHECKED - J.G. STRENKOSKI	REVISED

**STATE OF ILLINOIS  
 DEPARTMENT OF TRANSPORTATION**

**VARIOUS MOVABLE BRIDGES  
 LOCAL CENTRALIZED CONTROL AND OPERATION  
 BRANDON ROAD - CONTROL CIRCUIT - 21**

SHEET NO. 54 OF 93 SHEETS

BRANDON, Drawing 06-054			
F.A.P. RTE.	SECTION	COUNTY	TOTAL SHEETS
0341	2011-045-I	WILL	466
			SHEET NO. 379
CONTRACT NO. 60P55			
ILLINOIS FED. AID PROJECT			

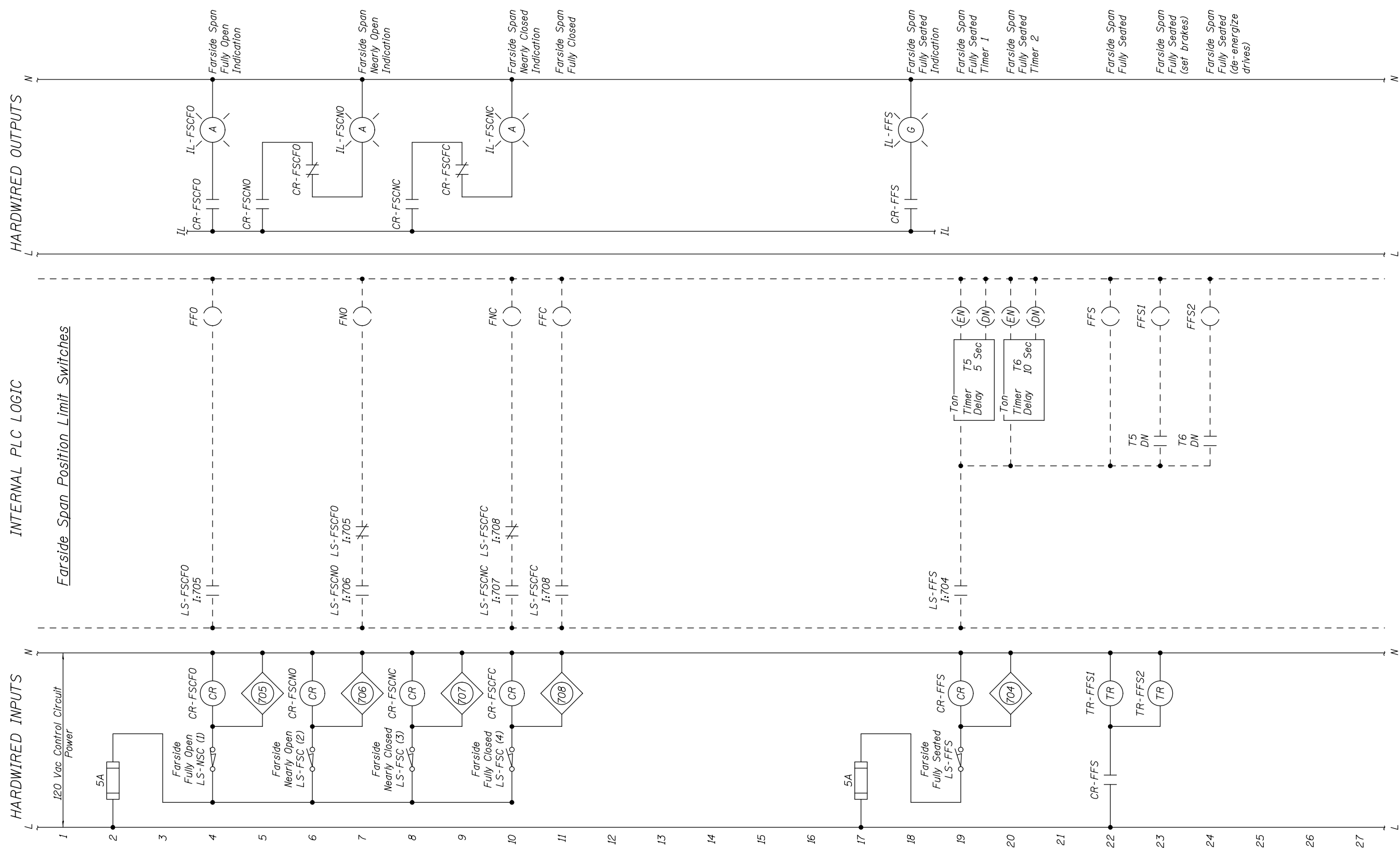

**NOTES:**  
 1. Provide additional de-bounce timers as required to condition PLC inputs for sensing devices.



USER NAME =	DESIGNED - R.I. PETERS	REVISED
	CHECKED - J.G. STRENKOSKI	REVISED
PLOT SCALE =	DRAWN - R.I. PETERS	REVISED
PLOT DATE =	CHECKED - J.G. STRENKOSKI	REVISED

**STATE OF ILLINOIS  
 DEPARTMENT OF TRANSPORTATION**

**VARIOUS MOVABLE BRIDGES  
 LOCAL CENTRALIZED CONTROL AND OPERATION  
 BRANDON ROAD - CONTROL CIRCUIT - 22**

SHEET NO. 55 OF 93 SHEETS

BRANDON, Drawing 06-055			
F.A.P. RTE.	SECTION	COUNTY	TOTAL SHEETS
0341	2011-045-I	WILL	466
			SHEET NO. 380
CONTRACT NO. 60P55			
ILLINOIS FED. AID PROJECT			



HARDWIRED INPUTS

INTERNAL PLC LOGIC

HARDWIRED OUTPUTS

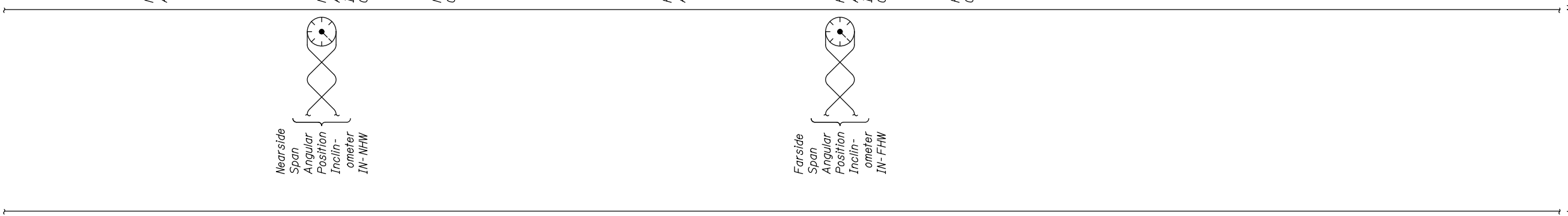
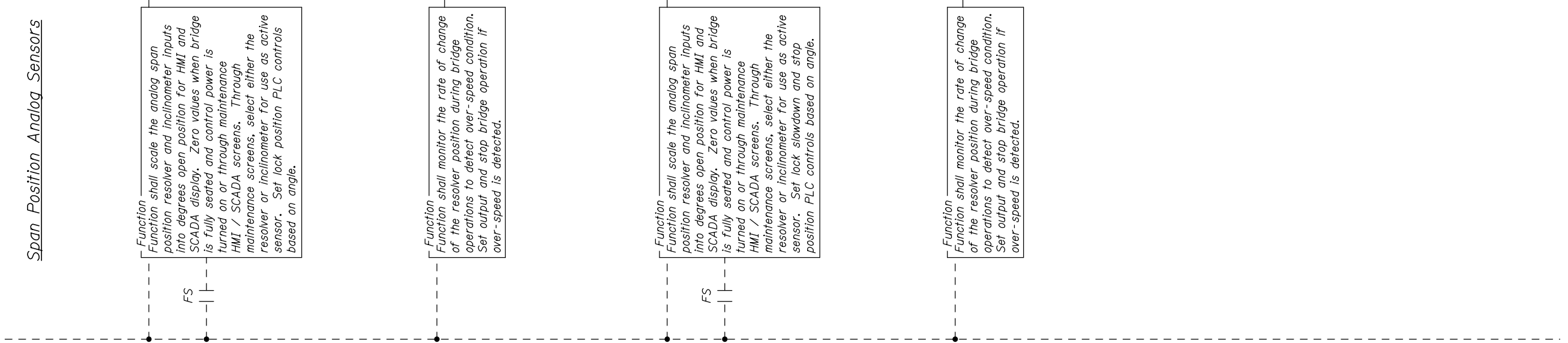
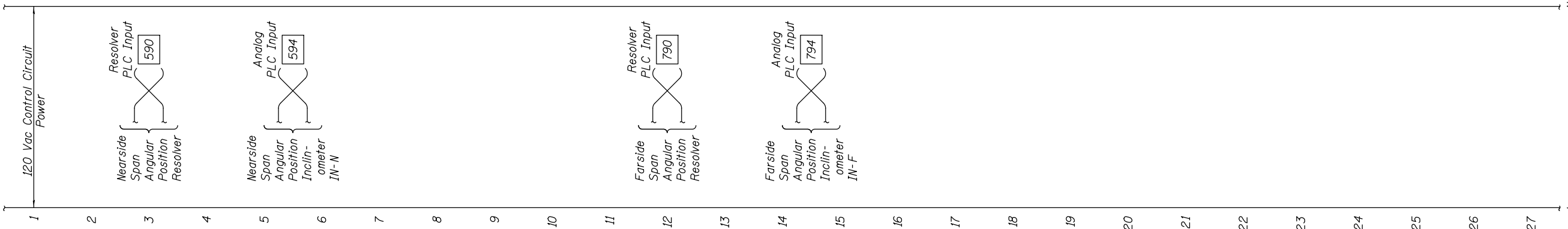

USER NAME =	DESIGNED - R.I. PETERS	REVISED	___
	CHECKED - J.G. STRENKOSKI	REVISED	___
PLOT SCALE =	DRAWN - R.I. PETERS	REVISED	___
PLOT DATE =	CHECKED - J.G. STRENKOSKI	REVISED	___

**STATE OF ILLINOIS  
DEPARTMENT OF TRANSPORTATION**

**VARIOUS MOVABLE BRIDGES  
LOCAL CENTRALIZED CONTROL AND OPERATION  
BRANDON ROAD - CONTROL CIRCUIT - 23**

SHEET NO. 56 OF 93 SHEETS

BRANDON, Drawing 06-056			
F.A.P. RTE.	SECTION	COUNTY	TOTAL SHEETS
0341	2011-045-I	WILL	466
			SHEET NO.
			381
CONTRACT NO. 60P55			
ILLINOIS FED. AID PROJECT			



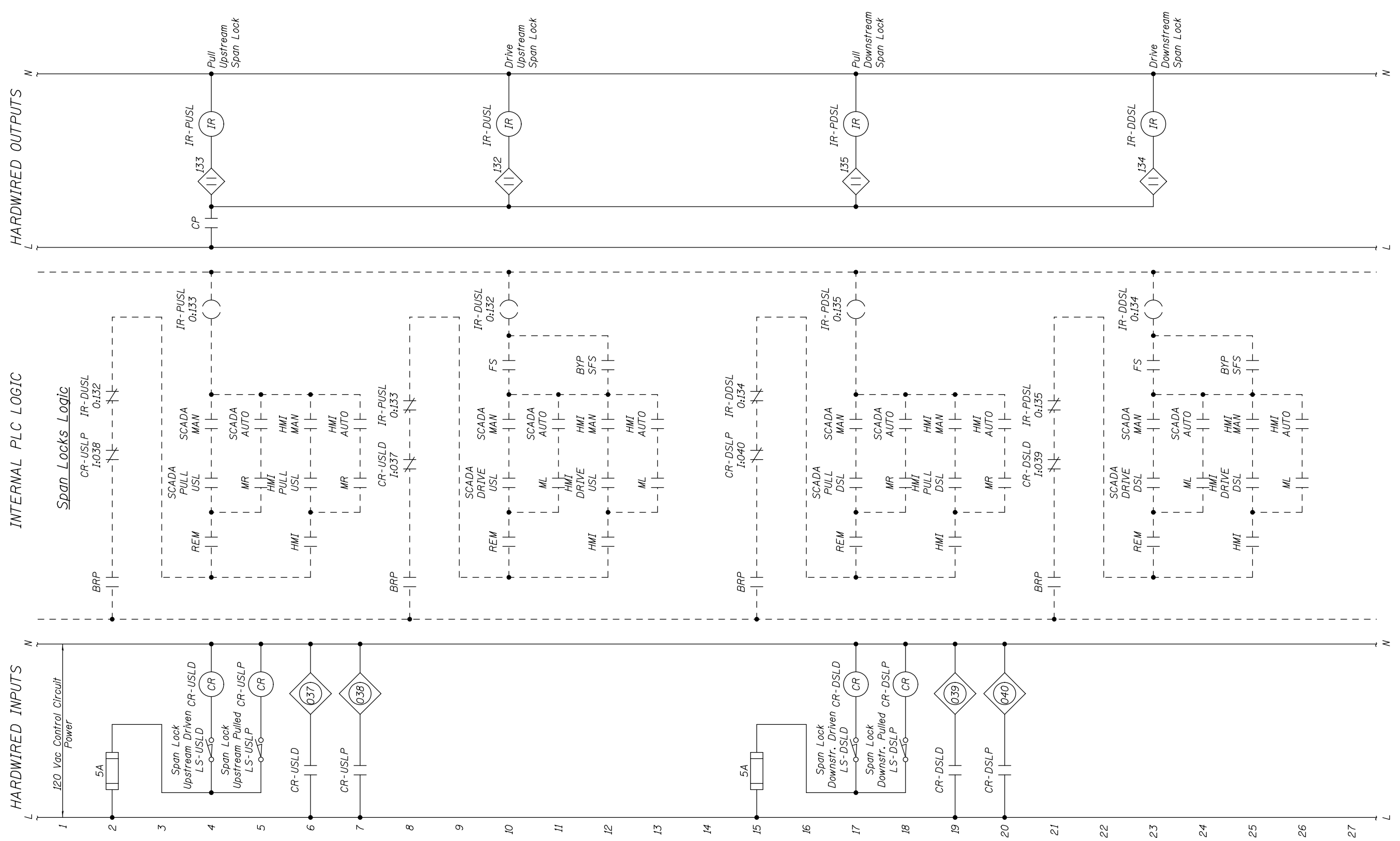

USER NAME =	DESIGNED - R.I. PETERS	REVISED	---
PLOT SCALE =	CHECKED - J.G. STRENKOSKI	REVISED	---
PLOT DATE =	DRAWN - R.I. PETERS	REVISED	---
	CHECKED - J.G. STRENKOSKI	REVISED	---

**STATE OF ILLINOIS  
DEPARTMENT OF TRANSPORTATION**

**VARIOUS MOVABLE BRIDGES  
LOCAL CENTRALIZED CONTROL AND OPERATION  
BRANDON ROAD - CONTROL CIRCUIT - 25**

SHEET NO. 58 OF 93 SHEETS

BRANDON, Drawing 06-058				
F.A.P. RTE.	SECTION	COUNTY	TOTAL SHEETS	SHEET NO.
0341	2011-045-I	WILL	466	383
CONTRACT NO. 60P55				
ILLINOIS FED. AID PROJECT				

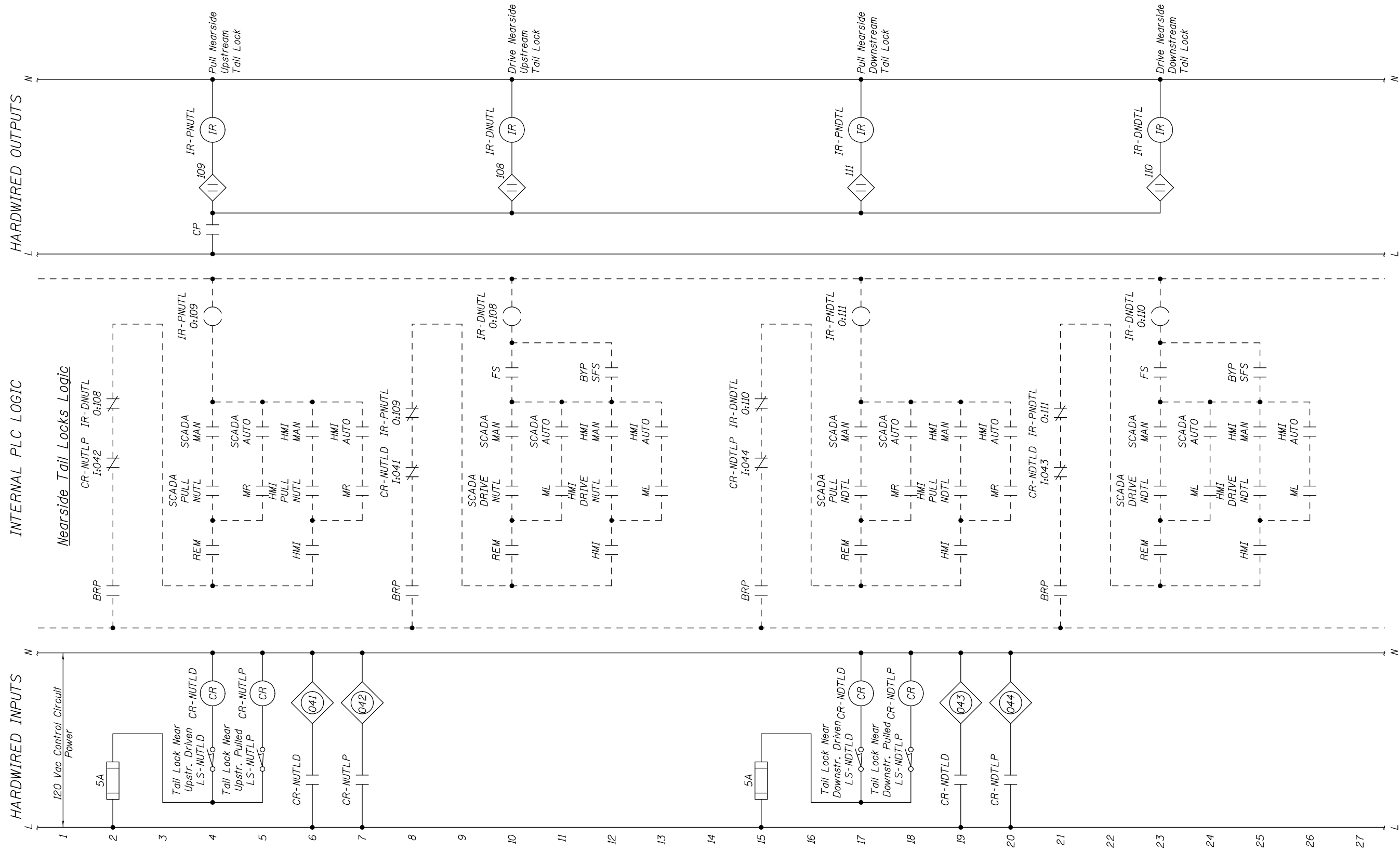

USER NAME =	DESIGNED - R.I. PETERS	REVISED	---
	CHECKED - J.G. STRENKOSKI	REVISED	---
PLOT SCALE =	DRAWN - R.I. PETERS	REVISED	---
PLOT DATE =	CHECKED - J.G. STRENKOSKI	REVISED	---

**STATE OF ILLINOIS  
DEPARTMENT OF TRANSPORTATION**

**VARIOUS MOVABLE BRIDGES  
LOCAL CENTRALIZED CONTROL AND OPERATION  
BRANDON ROAD - CONTROL CIRCUIT - 26**

SHEET NO. 59 OF 93 SHEETS

BRANDON, Drawing 06-059				
F.A.P. RTE.	SECTION	COUNTY	TOTAL SHEETS	SHEET NO.
0341	2011-045-I	WILL	466	384
CONTRACT NO. 60P55				
ILLINOIS FED. AID PROJECT				

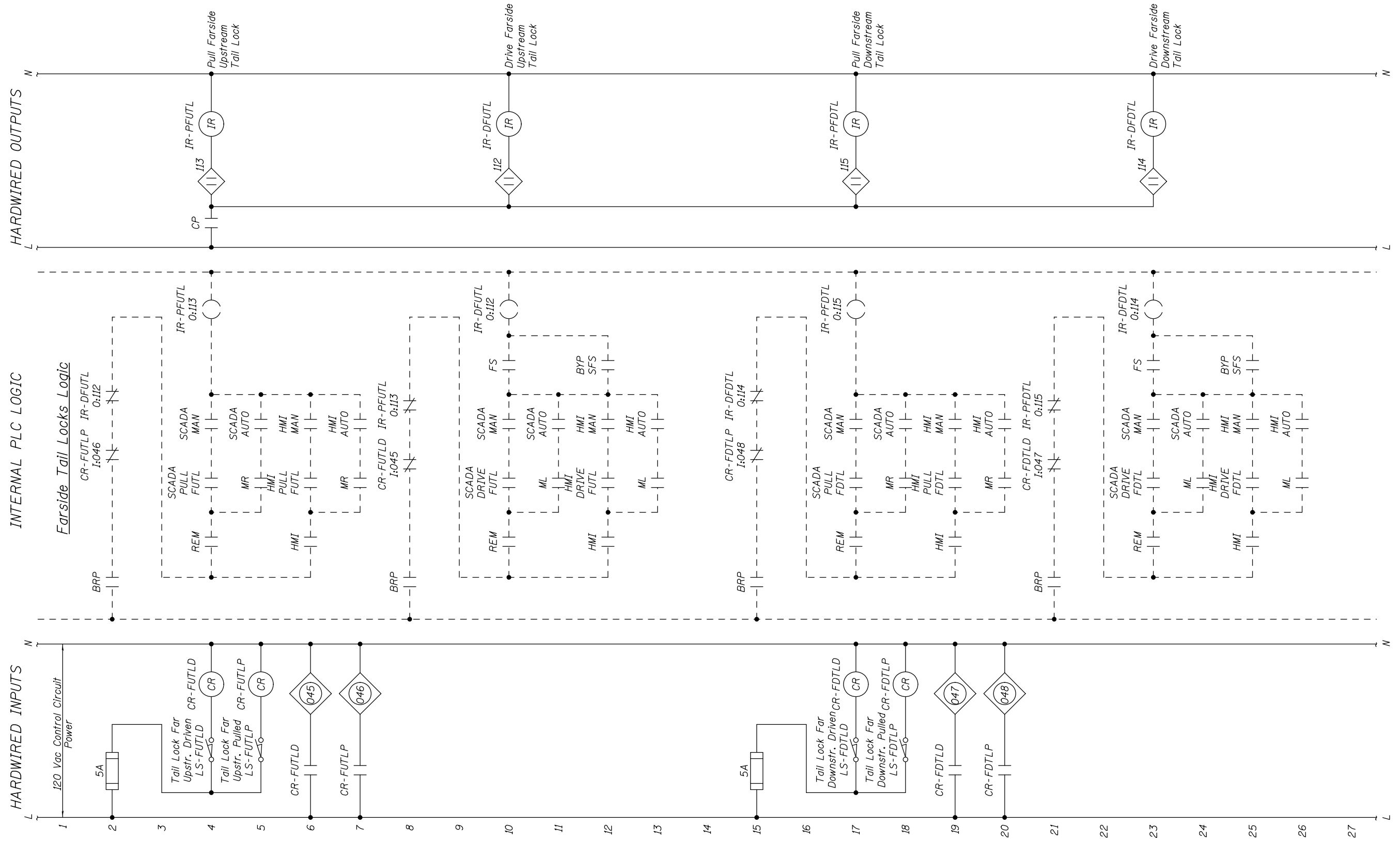

USER NAME =	DESIGNED - R.I. PETERS	REVISED	---
	CHECKED - J.G. STRENKOSKI	REVISED	---
PLOT SCALE =	DRAWN - R.I. PETERS	REVISED	---
PLOT DATE =	CHECKED - J.G. STRENKOSKI	REVISED	---

**STATE OF ILLINOIS  
DEPARTMENT OF TRANSPORTATION**

**VARIOUS MOVABLE BRIDGES  
LOCAL CENTRALIZED CONTROL AND OPERATION  
BRANDON ROAD - CONTROL CIRCUIT - 27**

F.A.P. RTE.	SECTION	COUNTY	TOTAL SHEETS	SHEET NO.
0341	2011-045-I	WILL	466	385
CONTRACT NO. 60P55				
ILLINOIS FED. AID PROJECT				

BRANDON, Drawing 06-060

SHEET NO. 60 OF 93 SHEETS

HARDWIRED INPUTS

INTERNAL PLC LOGIC

HARDWIRED OUTPUTS

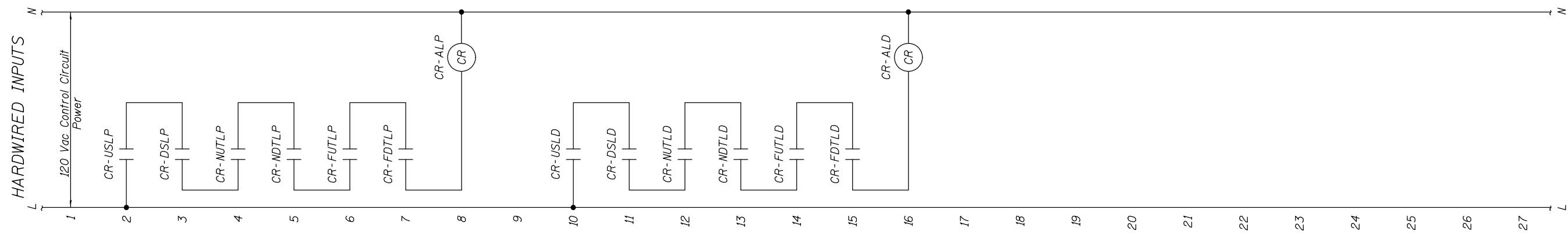

Span and Tail Locks Logic

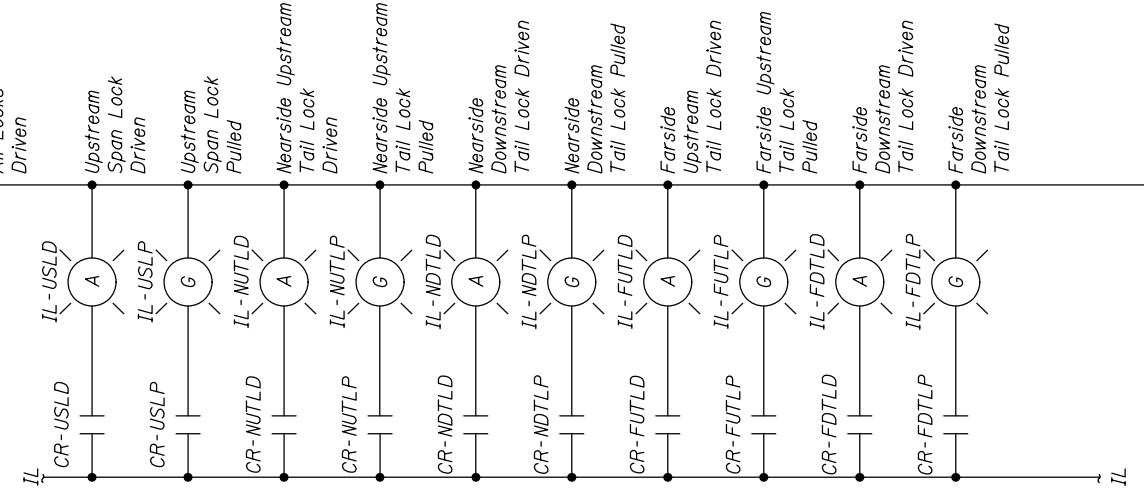
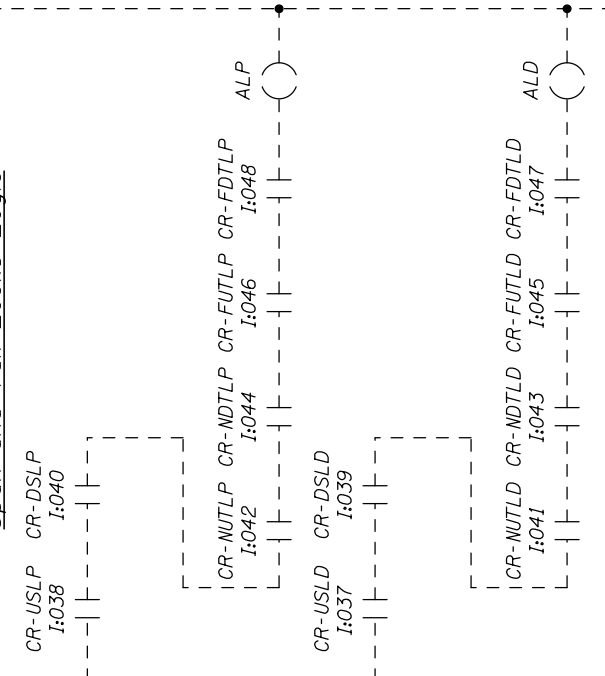

All Locks Pulled

All Locks Driven

Upstream Span Lock Driven

Upstream Span Lock Pulled

Nearside Upstream Tail Lock Driven

Nearside Upstream Tail Lock Pulled

Nearside Downstream Tail Lock Driven

Nearside Downstream Tail Lock Pulled

Farside Upstream Tail Lock Driven

Farside Upstream Tail Lock Pulled

Farside Downstream Tail Lock Driven

Farside Downstream Tail Lock Pulled



USER NAME =	DESIGNED - R.I. PETERS	REVISED	---
	CHECKED - J.G. STRENKOSKI	REVISED	---
PLOT SCALE =	DRAWN - R.I. PETERS	REVISED	---
PLOT DATE =	CHECKED - J.G. STRENKOSKI	REVISED	---

STATE OF ILLINOIS  
DEPARTMENT OF TRANSPORTATION

VARIOUS MOVABLE BRIDGES  
LOCAL CENTRALIZED CONTROL AND OPERATION  
BRANDON ROAD - CONTROL CIRCUIT - 28

SHEET NO. 61 OF 93 SHEETS

F.A.P. RTE.	SECTION	COUNTY	TOTAL SHEETS	SHEET NO.
0341	2011-045-I	WILL	466	386
CONTRACT NO. 60P55				

ILLINOIS FED. AID PROJECT

BRANDON, Drawing 06-061

Span Locks Control Circuits

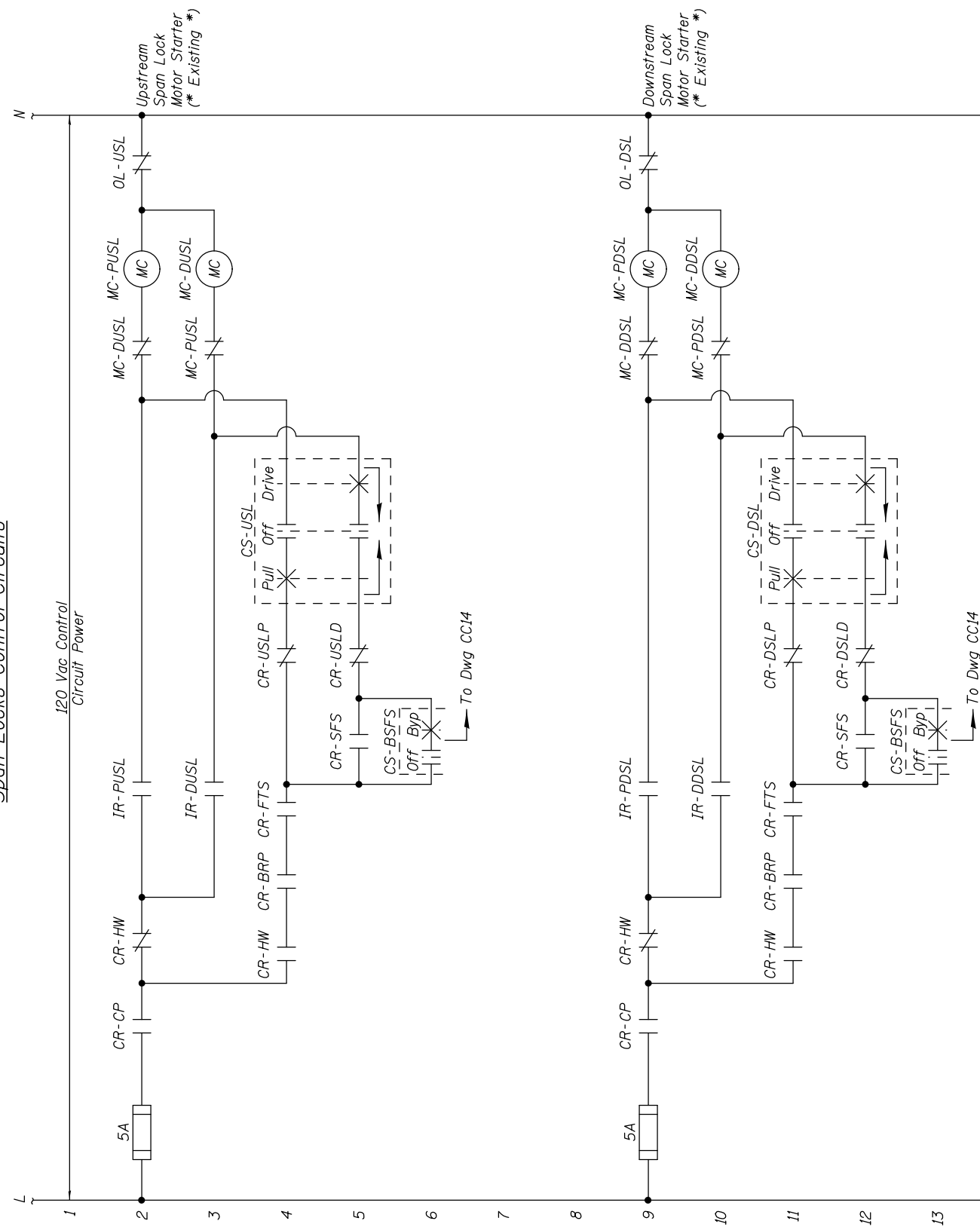

Tail Locks Control Circuits

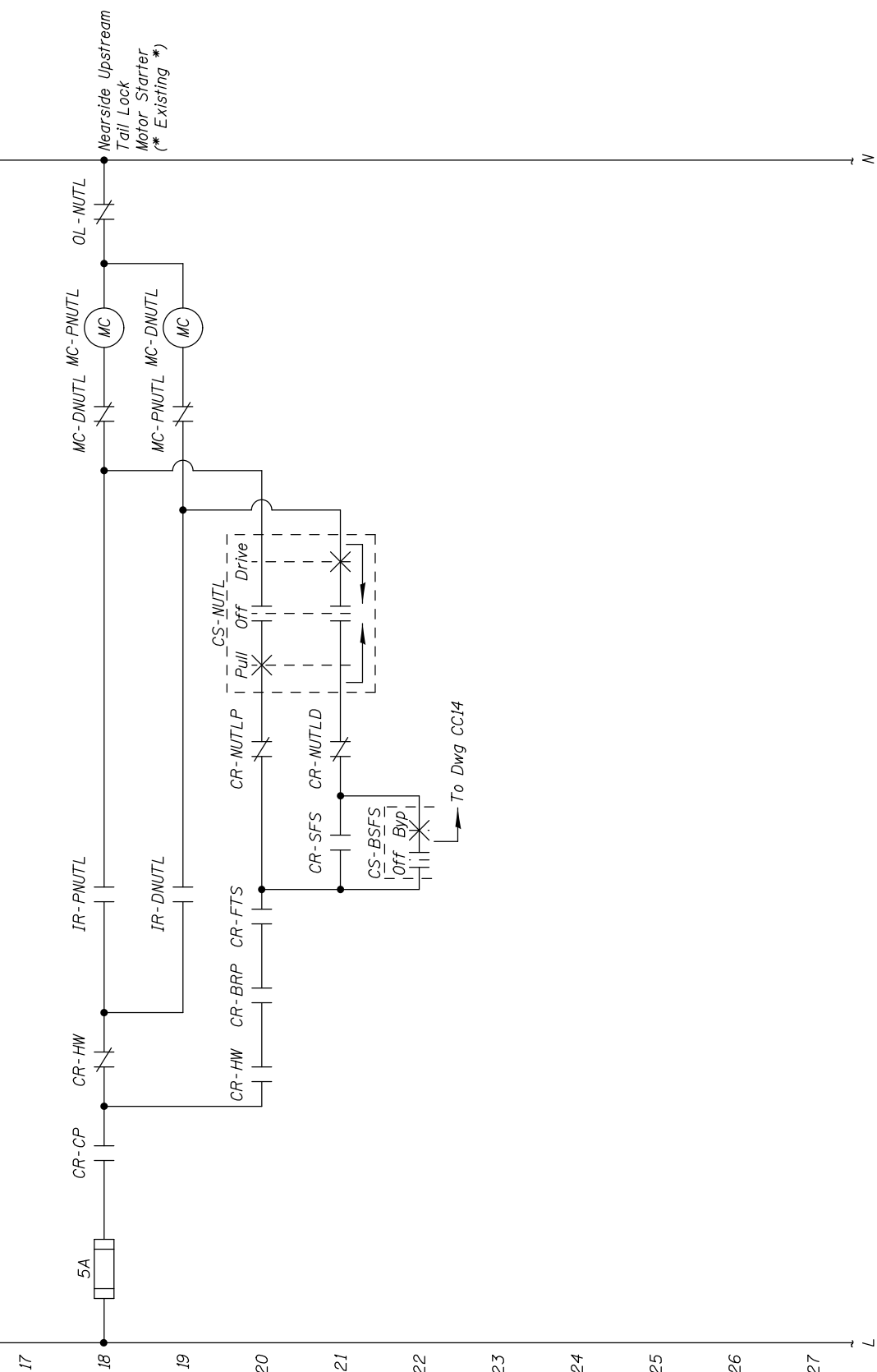

USER NAME =	DESIGNED - R.I. PETERS	REVISED	---
	CHECKED - J.G. STRENKOSKI	REVISED	---
PLOT SCALE =	DRAWN - R.I. PETERS	REVISED	---
PLOT DATE =	CHECKED - J.G. STRENKOSKI	REVISED	---

STATE OF ILLINOIS  
DEPARTMENT OF TRANSPORTATION

VARIOUS MOVABLE BRIDGES  
LOCAL CENTRALIZED CONTROL AND OPERATION  
BRANDON ROAD - CONTROL CIRCUIT - 29

SHEET NO. 62 OF 93 SHEETS

F.A.P. RTE.	SECTION	COUNTY	TOTAL SHEETS	SHEET NO.
0341	2011-045-I	WILL	466	387
CONTRACT NO. 60P55				

ILLINOIS FED. AID PROJECT

BRANDON, Drawing 06-062

Tail Locks Control Circuits (Cont.)

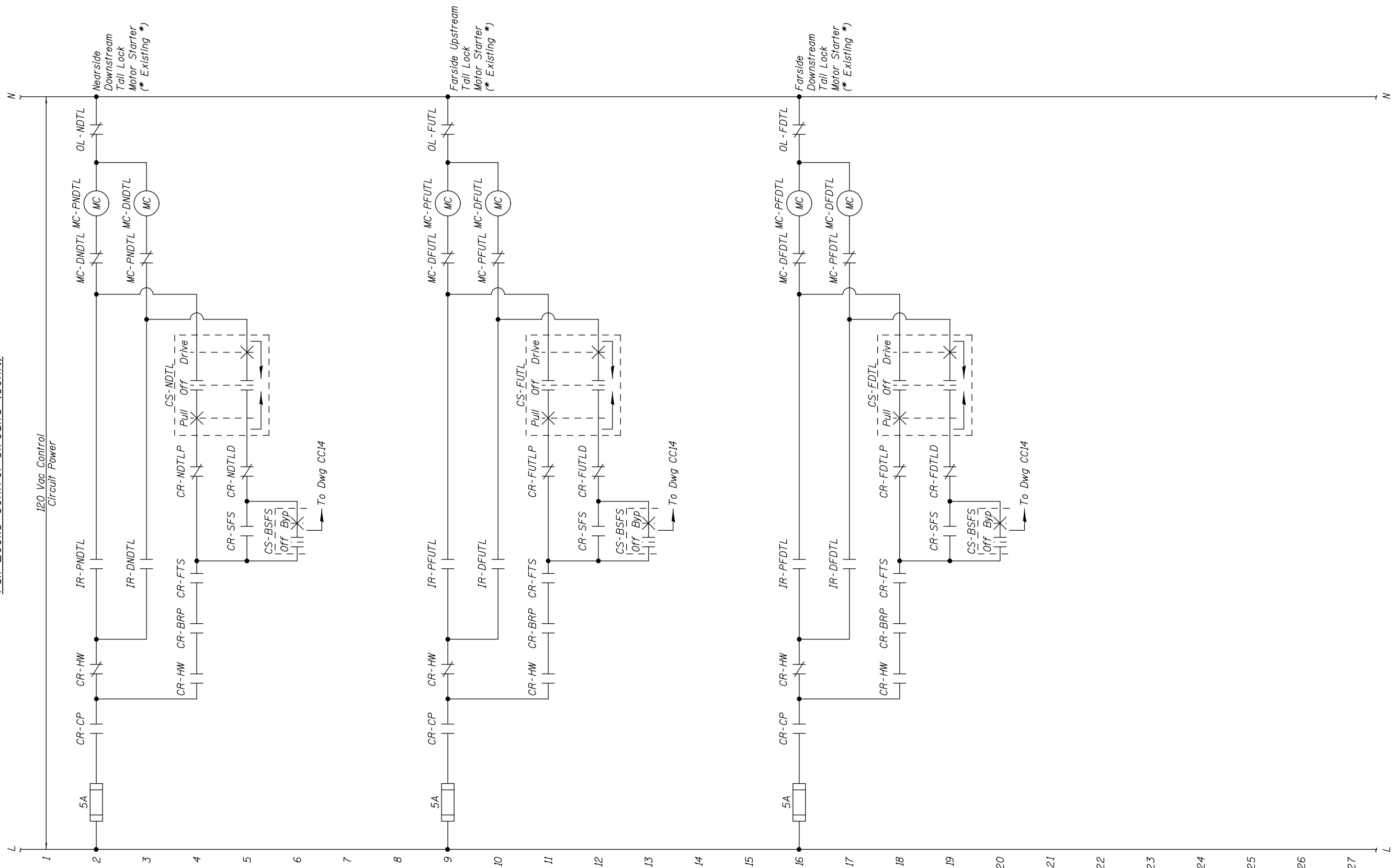

USER NAME =	DESIGNED - R.I. PETERS	REVISED	---
	CHECKED - J.G. STRENKOSKI	REVISED	---
PLOT SCALE =	DRAWN - R.I. PETERS	REVISED	---
PLOT DATE =	CHECKED - J.G. STRENKOSKI	REVISED	---

STATE OF ILLINOIS  
DEPARTMENT OF TRANSPORTATION

VARIOUS MOVABLE BRIDGES  
LOCAL CENTRALIZED CONTROL AND OPERATION  
BRANDON ROAD - CONTROL CIRCUIT - 30

SHEET NO. 63 OF 93 SHEETS

BRANDON, Drawing 06-063			
F.A.P. RTE.	SECTION	COUNTY	TOTAL SHEETS
0341	2011-045-I	WILL	466
			SHEET NO. 388
CONTRACT NO. 60P55			

ILLINOIS FED. AID PROJECT



HARDWIRED OUTPUTS

INTERNAL PLC LOGIC

HARDWIRED INPUTS

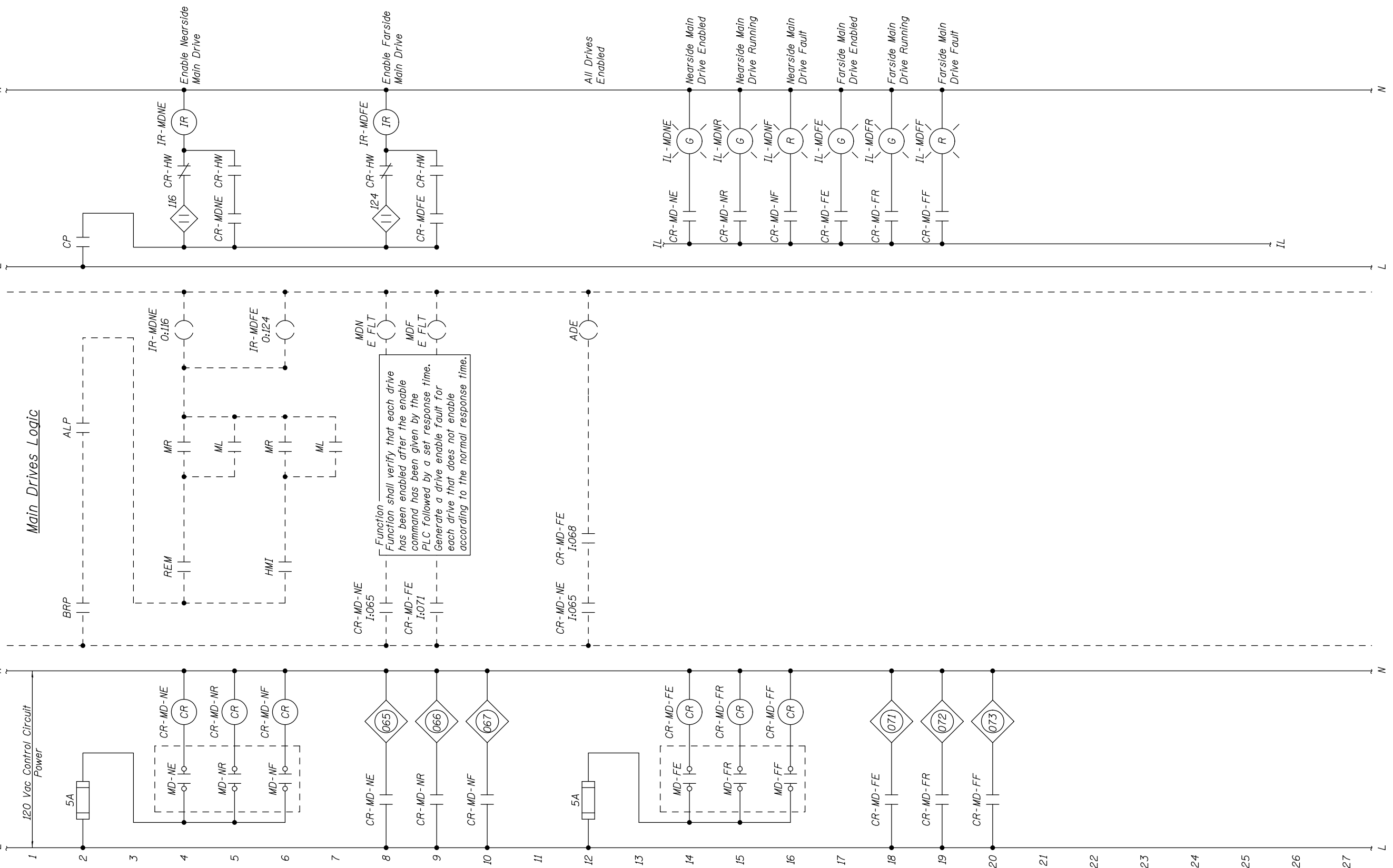

USER NAME =	DESIGNED - R.I. PETERS	REVISED	---
	CHECKED - J.G. STRENKOSKI	REVISED	---
PLOT SCALE =	DRAWN - R.I. PETERS	REVISED	---
PLOT DATE =	CHECKED - J.G. STRENKOSKI	REVISED	---

STATE OF ILLINOIS  
DEPARTMENT OF TRANSPORTATION

VARIOUS MOVABLE BRIDGES  
LOCAL CENTRALIZED CONTROL AND OPERATION  
BRANDON ROAD - CONTROL CIRCUIT - 31

SHEET NO. 64 OF 93 SHEETS

BRANDON, Drawing 06-064			
F.A.P. RTE.	SECTION	COUNTY	TOTAL SHEETS
0341	2011-045-I	WILL	466
			SHEET NO. 389
CONTRACT NO. 60P55			
ILLINOIS FED. AID PROJECT			

HARDWIRED OUTPUTS

INTERNAL PLC LOGIC

HARDWIRED INPUTS

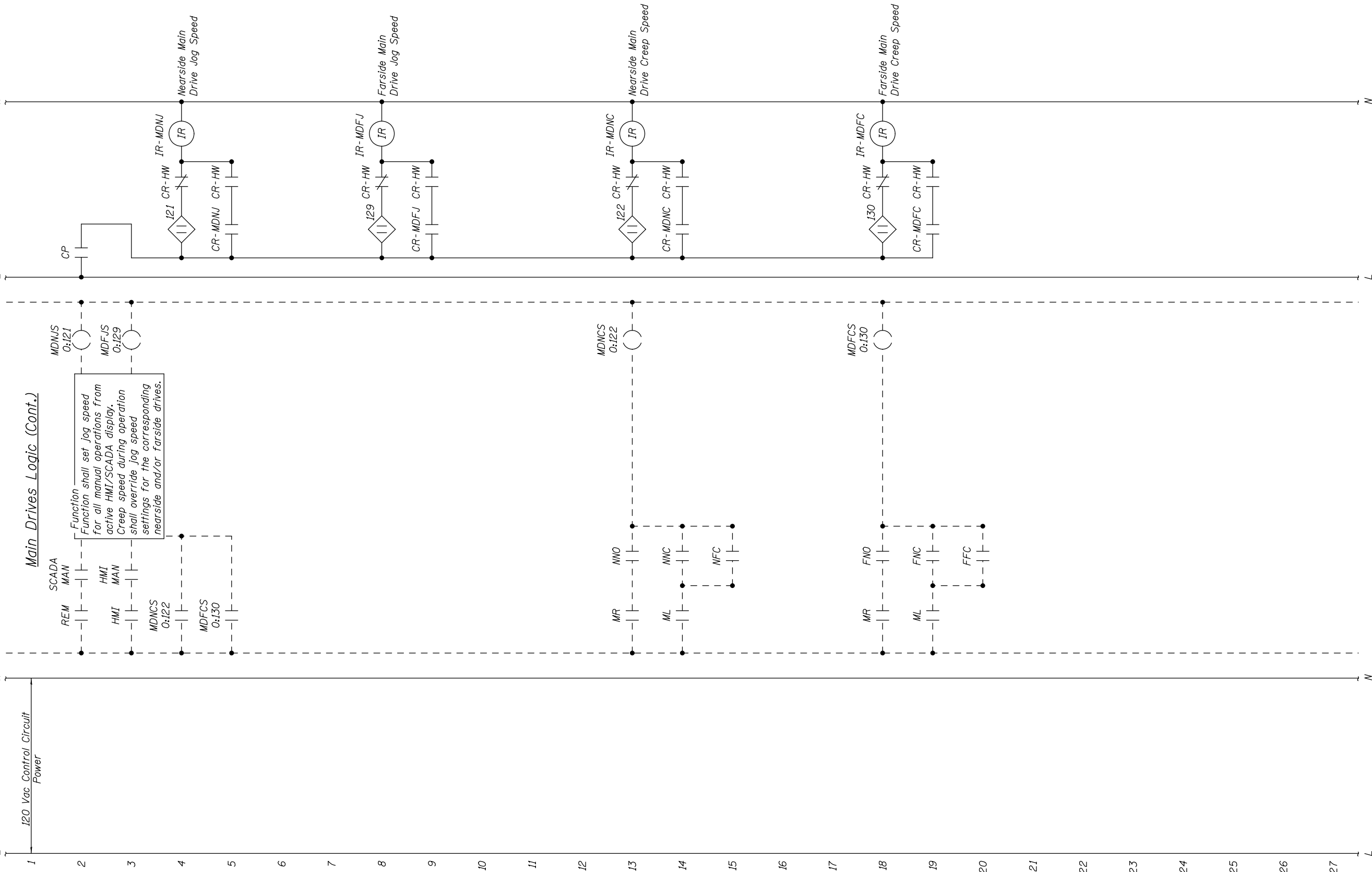

USER NAME =	DESIGNED - R.I. PETERS	REVISED	---
	CHECKED - J.G. STRENKOSKI	REVISED	---
PLOT SCALE =	DRAWN - R.I. PETERS	REVISED	---
PLOT DATE =	CHECKED - J.G. STRENKOSKI	REVISED	---

STATE OF ILLINOIS  
DEPARTMENT OF TRANSPORTATION

VARIOUS MOVABLE BRIDGES  
LOCAL CENTRALIZED CONTROL AND OPERATION  
BRANDON ROAD - CONTROL CIRCUIT - 32

F.A.P. RTE.	SECTION	COUNTY	TOTAL SHEETS	SHEET NO.
0341	2011-045-I	WILL	466	390
CONTRACT NO. 60P55				

SHEET NO. 65 OF 93 SHEETS

ILLINOIS FED. AID PROJECT

BRANDON, Drawing 06-065



HARDWIRED INPUTS

INTERNAL PLC LOGIC

HARDWIRED OUTPUTS

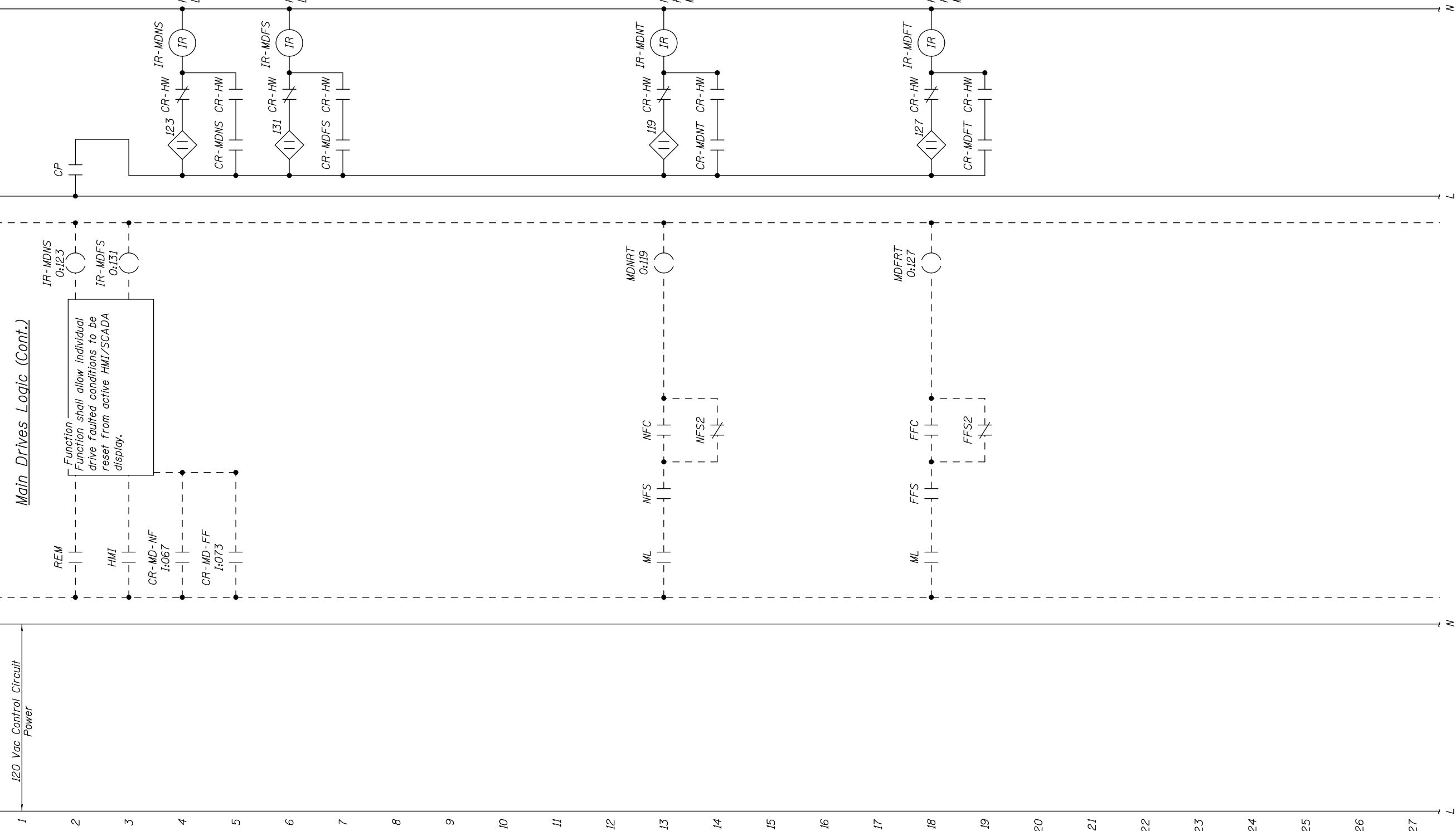

USER NAME =	DESIGNED - R.I. PETERS	REVISED	---
	CHECKED - J.G. STRENKOSKI	REVISED	---
PLOT SCALE =	DRAWN - R.I. PETERS	REVISED	---
PLOT DATE =	CHECKED - J.G. STRENKOSKI	REVISED	---

STATE OF ILLINOIS  
DEPARTMENT OF TRANSPORTATION

VARIOUS MOVABLE BRIDGES  
LOCAL CENTRALIZED CONTROL AND OPERATION  
BRANDON ROAD - CONTROL CIRCUIT - 33

F.A.P. RTE.	SECTION	COUNTY	TOTAL SHEETS	SHEET NO.
0341	2011-045-I	WILL	466	391
CONTRACT NO. 60P55				

SHEET NO. 66 OF 93 SHEETS

ILLINOIS FED. AID PROJECT

BRANDON, Drawing 06-066

HARDWIRED INPUTS

INTERNAL PLC LOGIC

HARDWIRED OUTPUTS

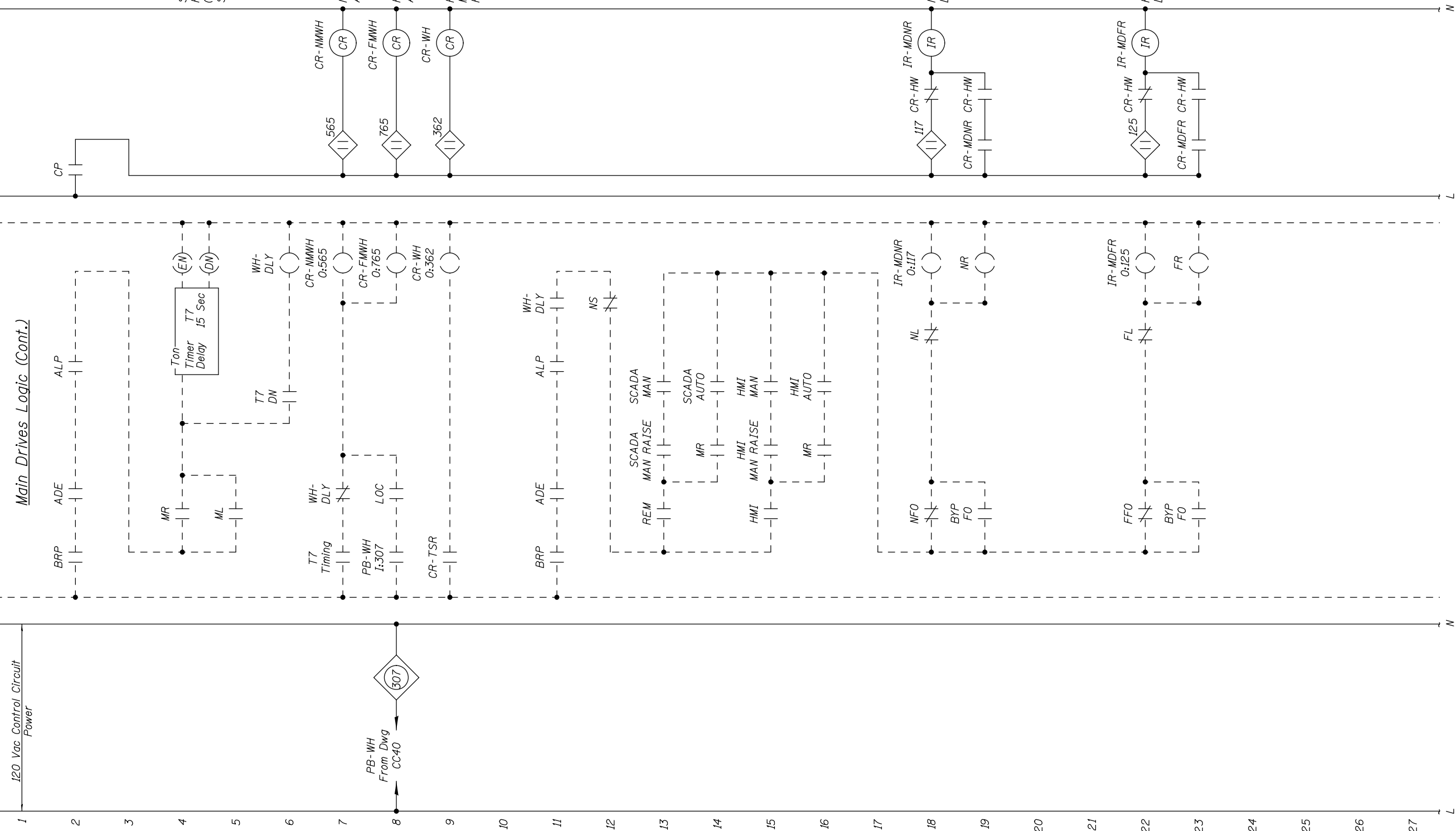

USER NAME =	DESIGNED - R.I. PETERS	REVISED	___
	CHECKED - J.G. STRENKOSKI	REVISED	___
PLOT SCALE =	DRAWN - R.I. PETERS	REVISED	___
PLOT DATE =	CHECKED - J.G. STRENKOSKI	REVISED	___

STATE OF ILLINOIS  
DEPARTMENT OF TRANSPORTATION

VARIOUS MOVABLE BRIDGES  
LOCAL CENTRALIZED CONTROL AND OPERATION  
BRANDON ROAD - CONTROL CIRCUIT - 34

SHEET NO. 67 OF 93 SHEETS

F.A.P. RTE.	SECTION	COUNTY	TOTAL SHEETS	SHEET NO.
0341	2011-045-I	WILL	466	392
CONTRACT NO. 60P55				

ILLINOIS FED. AID PROJECT

BRANDON, Drawing 06-067

HARDWIRED OUTPUTS

INTERNAL PLC LOGIC

HARDWIRED INPUTS

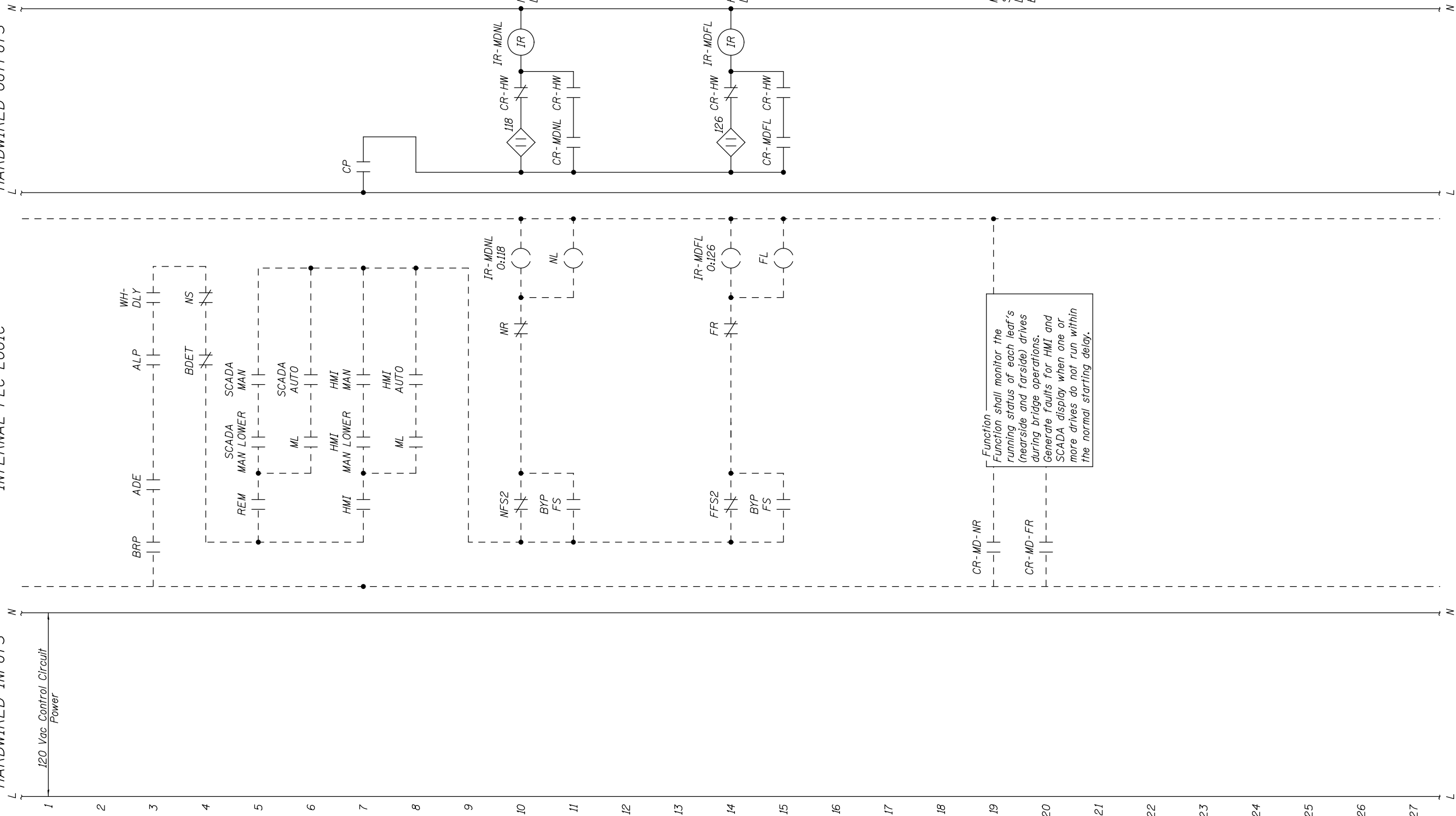

Function shall monitor the running status of each leaf's (nearside and farside) drives during bridge operations. Generate faults for HMI and SCADA display when one or more drives do not run within the normal starting delay.

Monitor Run Status of Drives During Bridge Operation



USER NAME =	DESIGNED - R.I. PETERS	REVISED	---
	CHECKED - J.G. STRENKOSKI	REVISED	---
PLOT SCALE =	DRAWN - R.I. PETERS	REVISED	---
PLOT DATE =	CHECKED - J.G. STRENKOSKI	REVISED	---

STATE OF ILLINOIS  
DEPARTMENT OF TRANSPORTATION

VARIOUS MOVABLE BRIDGES  
LOCAL CENTRALIZED CONTROL AND OPERATION  
BRANDON ROAD - CONTROL CIRCUIT - 35

SHEET NO. 68 OF 93 SHEETS

F.A.P. RTE.	SECTION	COUNTY	TOTAL SHEETS	SHEET NO.
0341	2011-045-I	WILL	466	393
CONTRACT NO. 60P55				

ILLINOIS FED. AID PROJECT

BRANDON, Drawing 06-068

HARDWIRED OUTPUTS

INTERNAL PLC LOGIC

HARDWIRED INPUTS

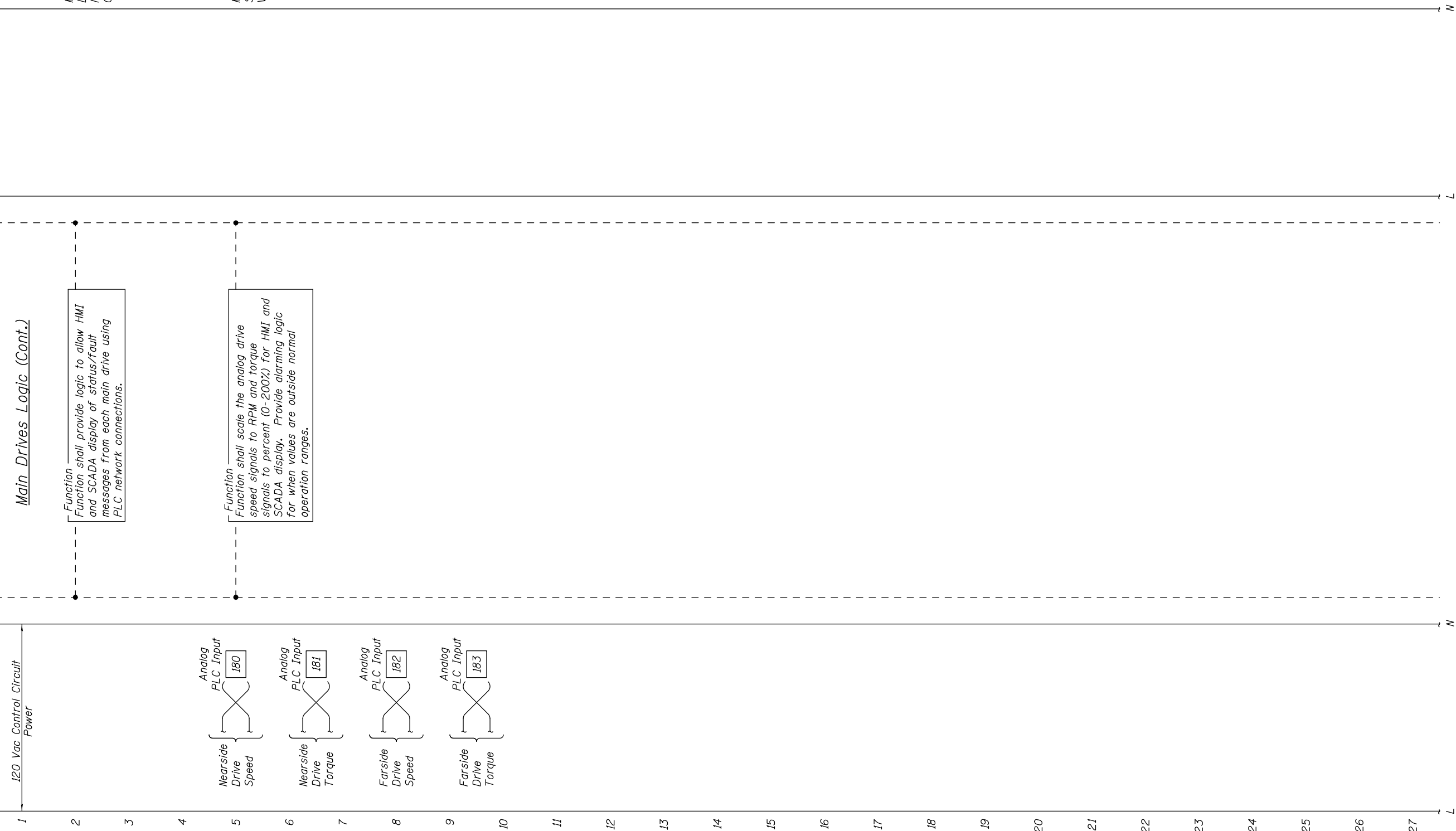

USER NAME =	DESIGNED - R.I. PETERS	REVISED	---
	CHECKED - J.G. STRENKOSKI	REVISED	---
PLOT SCALE =	DRAWN - R.I. PETERS	REVISED	---
PLOT DATE =	CHECKED - J.G. STRENKOSKI	REVISED	---

STATE OF ILLINOIS  
DEPARTMENT OF TRANSPORTATION

VARIOUS MOVABLE BRIDGES  
LOCAL CENTRALIZED CONTROL AND OPERATION  
BRANDON ROAD - CONTROL CIRCUIT - 36

SHEET NO. 69 OF 93 SHEETS

BRANDON, Drawing 06-069			
F.A.P. RTE.	SECTION	COUNTY	TOTAL SHEETS
0341	2011-045-I	WILL	466
		SHEET NO. 394	
CONTRACT NO. 60P55			
ILLINOIS FED. AID PROJECT			



Main Drive Hardwired Control Circuits (Cont.)

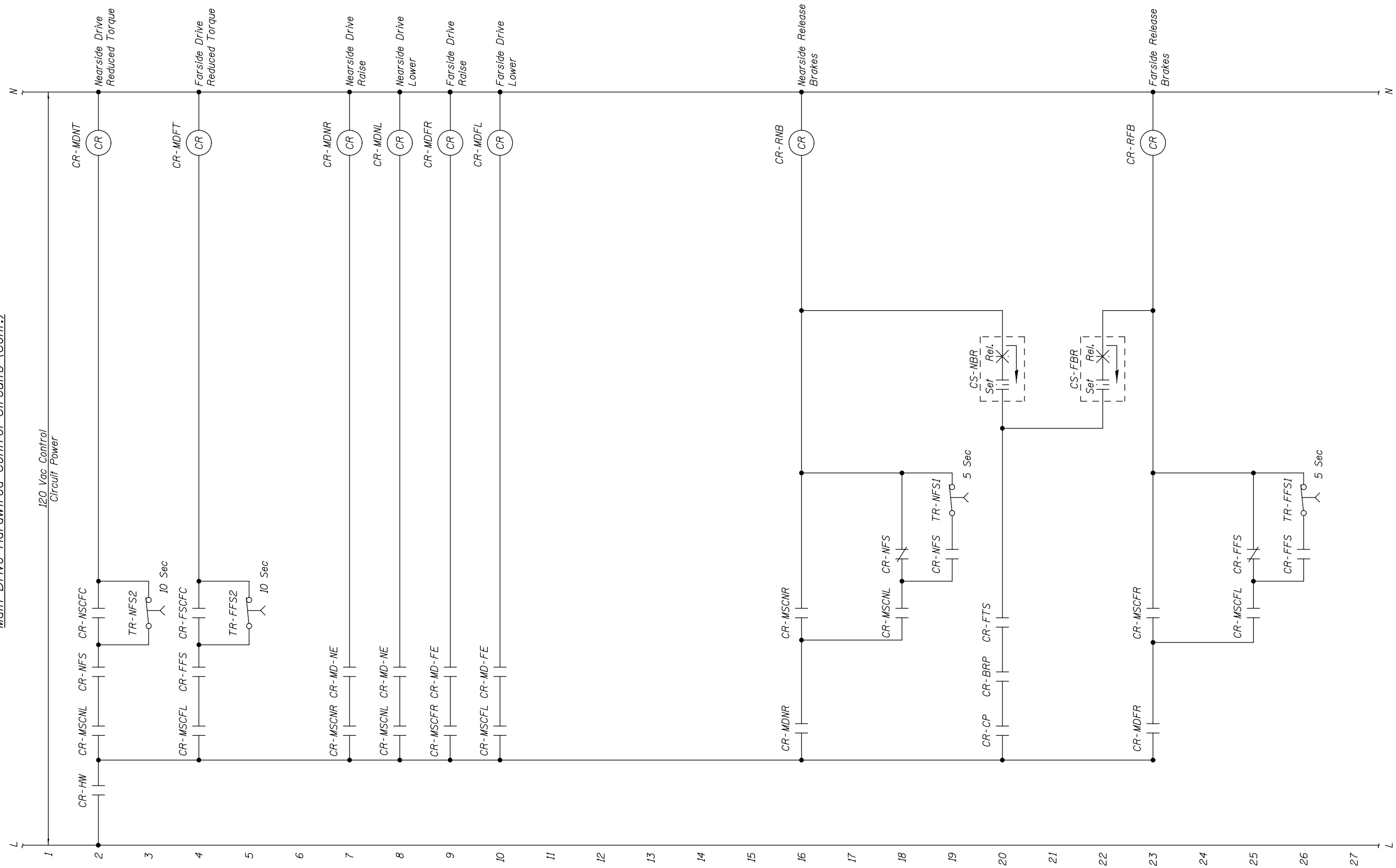

USER NAME =	DESIGNED - R.I. PETERS	REVISED	---
	CHECKED - J.G. STRENKOSKI	REVISED	---
PLOT SCALE =	DRAWN - R.I. PETERS	REVISED	---
PLOT DATE =	CHECKED - J.G. STRENKOSKI	REVISED	---

STATE OF ILLINOIS  
DEPARTMENT OF TRANSPORTATION

VARIOUS MOVABLE BRIDGES  
LOCAL CENTRALIZED CONTROL AND OPERATION  
BRANDON ROAD - CONTROL CIRCUIT - 38

SHEET NO. 71 OF 93 SHEETS

BRANDON, Drawing 06-071		TOTAL SHEETS		SHEET NO.	
F.A.P. RTE.	SECTION	COUNTY	466	396	
0341	2011-045-I	WILL	CONTRACT NO. 60P55		

ILLINOIS FED. AID PROJECT



Main Drive Hardwired Control Circuits (Cont.)



USER NAME =	DESIGNED - R.I. PETERS	REVISED	---
	CHECKED - J.G. STRENKOSKI	REVISED	---
PLOT SCALE =	DRAWN - R.I. PETERS	REVISED	---
PLOT DATE =	CHECKED - J.G. STRENKOSKI	REVISED	---

**STATE OF ILLINOIS  
DEPARTMENT OF TRANSPORTATION**

**VARIOUS MOVABLE BRIDGES  
LOCAL CENTRALIZED CONTROL AND OPERATION  
BRANDON ROAD - CONTROL CIRCUIT - 39**

SHEET NO. 72 OF 93 SHEETS

BRANDON, Drawing 06-072				
F.A.P. RTE.	SECTION	COUNTY	TOTAL SHEETS	SHEET NO.
0341	2011-045-I	WILL	466	397
CONTRACT NO. 60P55				
ILLINOIS FED. AID PROJECT				

Warning Horns Power

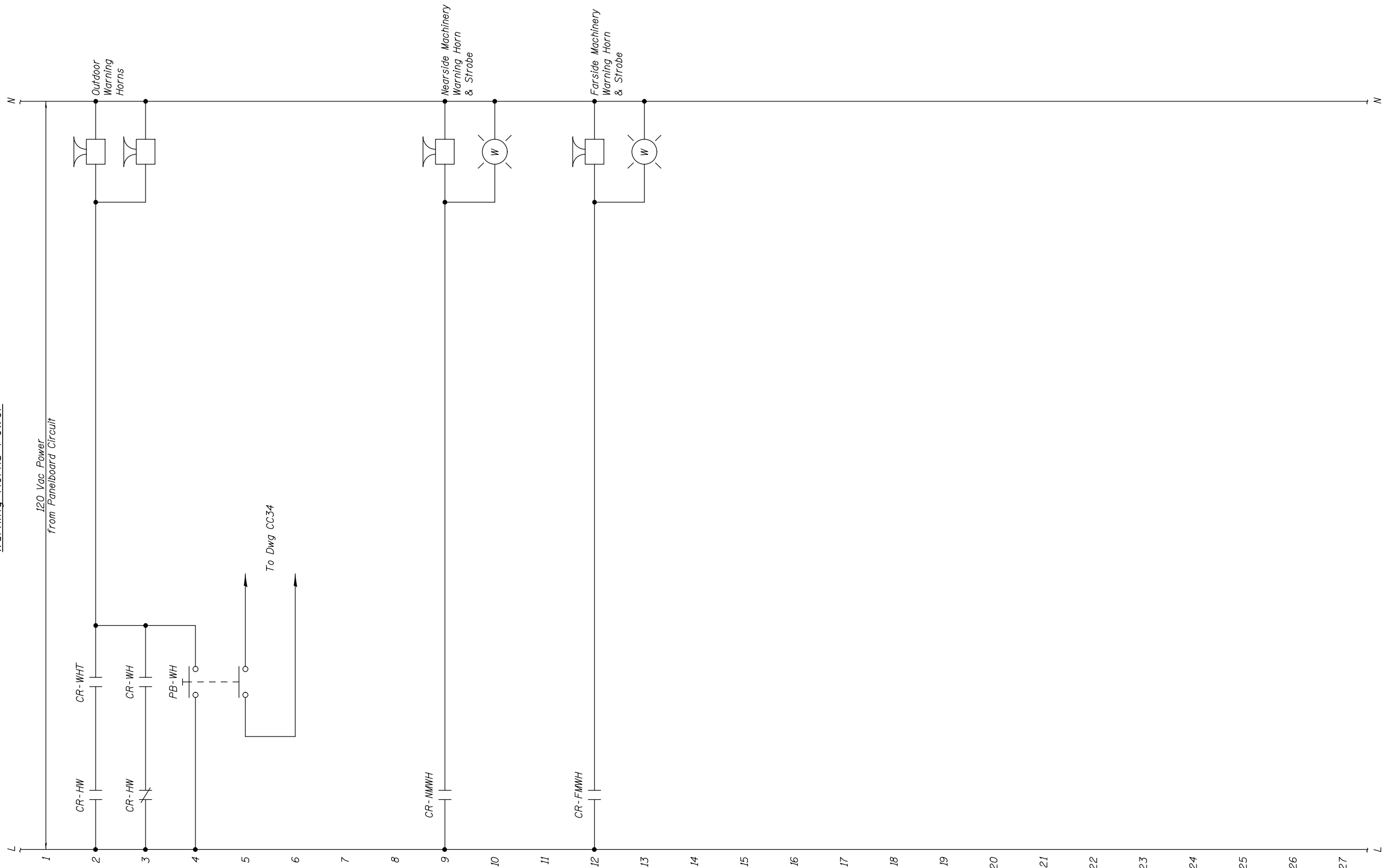

USER NAME =	DESIGNED - R.I. PETERS	REVISED	---
	CHECKED - J.G. STRENKOSKI	REVISED	---
PLOT SCALE =	DRAWN - R.I. PETERS	REVISED	---
PLOT DATE =	CHECKED - J.G. STRENKOSKI	REVISED	---

STATE OF ILLINOIS  
DEPARTMENT OF TRANSPORTATION

VARIOUS MOVABLE BRIDGES  
LOCAL CENTRALIZED CONTROL AND OPERATION  
BRANDON ROAD - CONTROL CIRCUIT - 40

SHEET NO. 73 OF 93 SHEETS

BRANDON, Drawing 06-073			
F.A.P. RTE.	SECTION	COUNTY	TOTAL SHEETS
0341	2011-045-I	WILL	466
			SHEET NO. 398
CONTRACT NO. 60P55			
ILLINOIS FED. AID PROJECT			

HARDWIRED LOGIC

120 Vac from Drive Cabinet Circuit

NEARSIDE MAIN DRIVE - CONTROL CIRCUIT

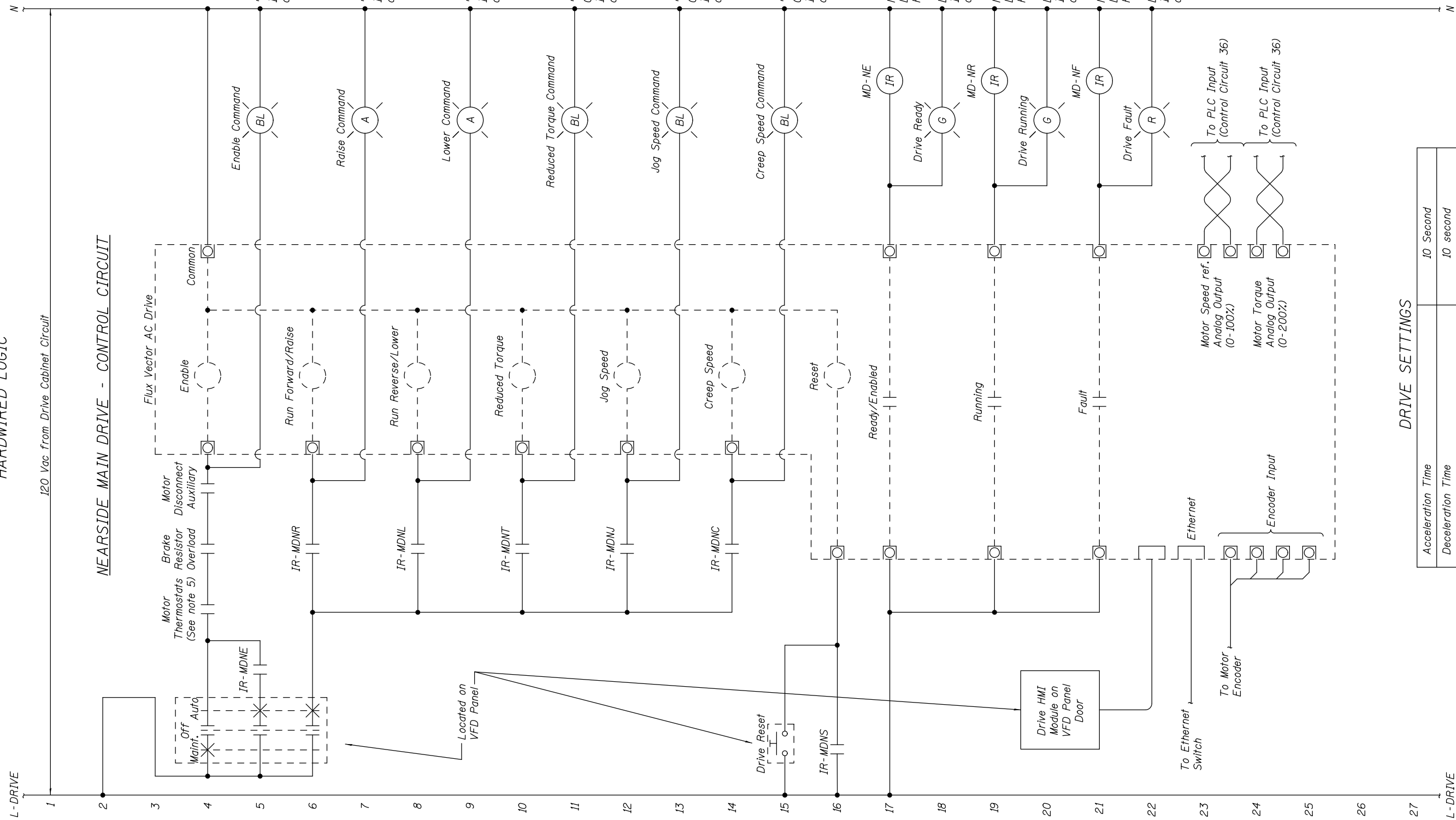

NOTES:

- Indicator Light shall be mounted on the VFD Panel and shall be push-to-test type.
- Maintenance mode is intended to be used for setup and testing with the drive HMI unit.
- The Drive shall be programmed or configured to fault if the the Encoder feedback is lost during operation.
- The Drive Ethernet connection is intended to allow the PLC to access drive fault messages and drive operating conditions. No control operations shall be performed using this connection.
- Use Drive manufacturer's dedicated inputs for Motor Thermostats and Braking Resistor Overloads if available.

DRIVE SETTINGS

Acceleration Time	10 Second
Deceleration Time	10 second
Stop Mode	Coast
Auto Start	False
Auto Restart	False
Motor Stall Time	20 Seconds
Maximum Torque Limit	150% Motor rated

Note: All settings shall be adjusted as required in the field.



USER NAME =	DESIGNED - R.I. PETERS	REVISED	---
	CHECKED - J.G. STRENKOSKI	REVISED	---
PLOT SCALE =	DRAWN - R.I. PETERS	REVISED	---
PLOT DATE =	CHECKED - J.G. STRENKOSKI	REVISED	---

STATE OF ILLINOIS  
DEPARTMENT OF TRANSPORTATION

VARIOUS MOVABLE BRIDGES  
LOCAL CENTRALIZED CONTROL AND OPERATION  
BRANDON ROAD - CONTROL CIRCUIT - 41

SHEET NO. 74 OF 93 SHEETS

BRANDON, Drawing 06-074			
F.A.P. RTE.	SECTION	COUNTY	TOTAL SHEETS
0341	2011-045-I	WILL	466
			SHEET NO. 399
CONTRACT NO. 60P55			
ILLINOIS FED. AID PROJECT			

HARDWIRED LOGIC

120 Vac from Drive Cabinet Circuit

FARSIDE MAIN DRIVE - CONTROL CIRCUIT

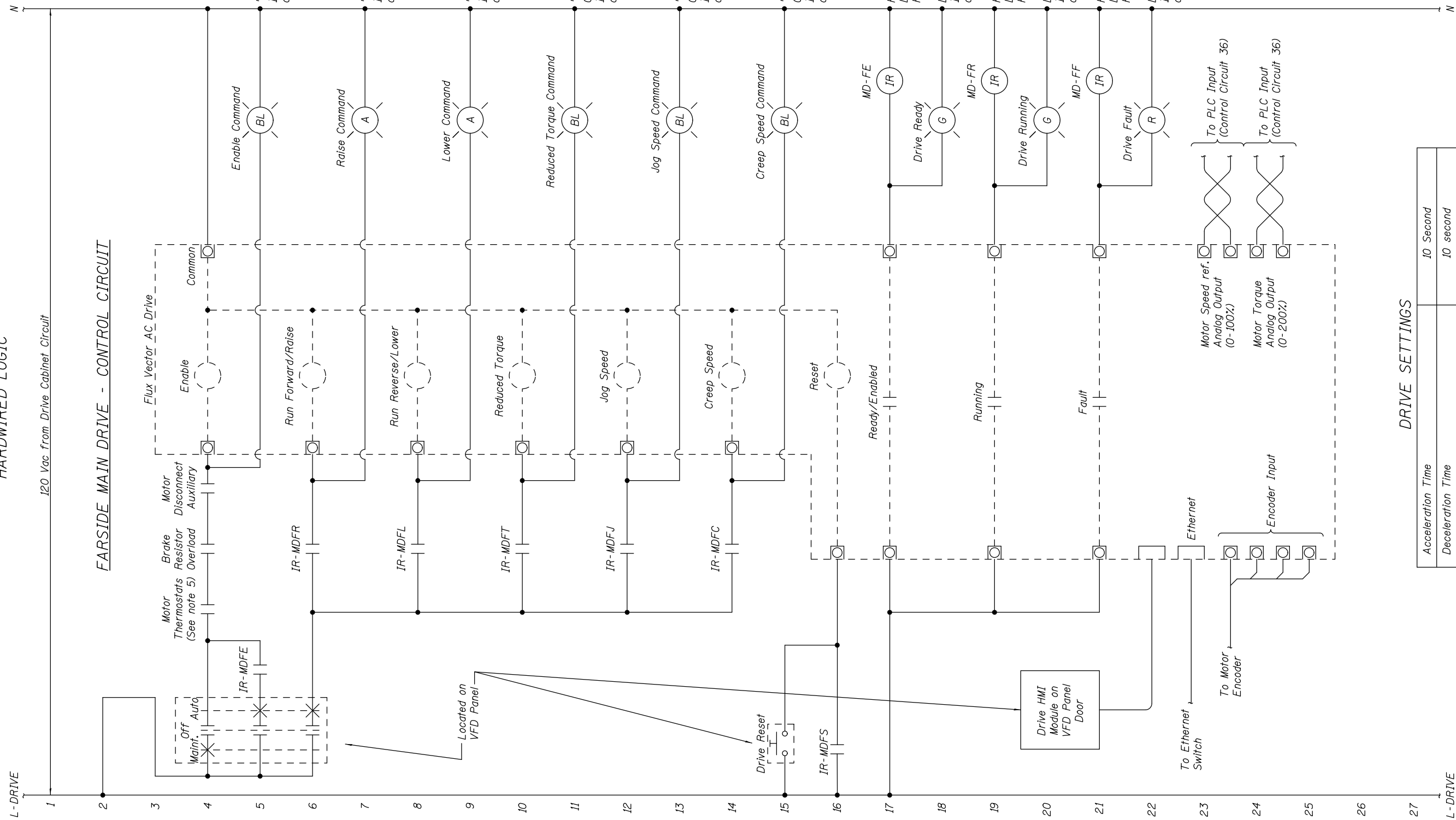

NOTES:

- Indicator Light shall be mounted on the VFD Panel and shall be push-to-test type.
- Maintenance mode is intended to be used for setup and testing with the drive HMI unit.
- The Drive shall be programmed or configured to fault if the the Encoder feedback is lost during operation.
- The Drive Ethernet connection is intended to allow the PLC to access drive fault messages and drive operating conditions. No control operations shall be performed using this connection.
- Use Drive manufacturer's dedicated inputs for Motor Thermostats and Braking Resistor Overloads if available.

DRIVE SETTINGS

Acceleration Time	10 Second
Deceleration Time	10 second
Stop Mode	Coast
Auto Start	False
Auto Restart	False
Motor Stall Time	20 Seconds
Maximum Torque Limit	150% Motor rated

Note: All settings shall be adjusted as required in the field.



USER NAME =	DESIGNED - R.I. PETERS	REVISED	---
	CHECKED - J.G. STRENKOSKI	REVISED	---
PLOT SCALE =	DRAWN - R.I. PETERS	REVISED	---
PLOT DATE =	CHECKED - J.G. STRENKOSKI	REVISED	---

STATE OF ILLINOIS  
DEPARTMENT OF TRANSPORTATION

VARIOUS MOVABLE BRIDGES  
LOCAL CENTRALIZED CONTROL AND OPERATION  
BRANDON ROAD - CONTROL CIRCUIT - 42

SHEET NO. 75 OF 93 SHEETS

F.A.P. RTE.	SECTION	COUNTY	TOTAL SHEETS	SHEET NO.
0341	2011-045-I	WILL	466	400
CONTRACT NO. 60P55				

BRANDON, Drawing 06-075

ILLINOIS FED. AID PROJECT