

CONTRACT NO. 70119

F.A.P. RTE.	SECTION	COUNTY	TOTAL SHEETS	SHEET NO.
332		VERMILION	30	1

• (RX, 48Z-1RS-1 & 147R-1RS)

STATE OF ILLINOIS
DEPARTMENT OF TRANSPORTATION
DIVISION OF HIGHWAYS

PLANS FOR PROPOSED HIGHWAY IMPROVEMENT

FAP ROUTE 332 (IL-1 /US-136)
SECTION (RX,48Z-1)RS-1 & (47R-1)RS
VERMILION COUNTY
PROJECT NHF-0332(081)

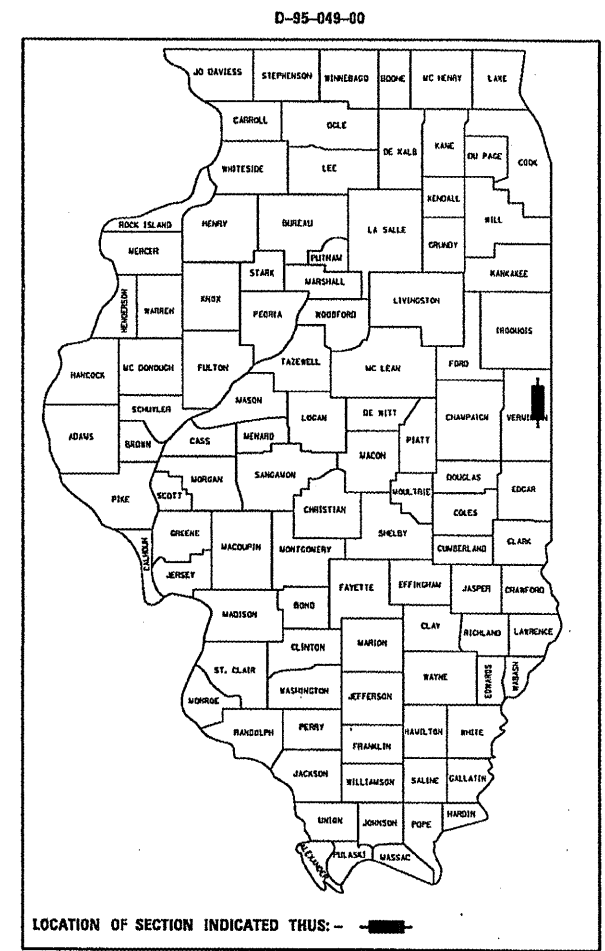

FOR INDEX OF SHEETS, SEE SHEET NO. 2
FOR SUMMARY OF QUANTITIES, SEE SHEET NO. 5-6

C-95-111-00

3P RESURFACING FROM LIBERTY LANE TO WINTER AVENUE

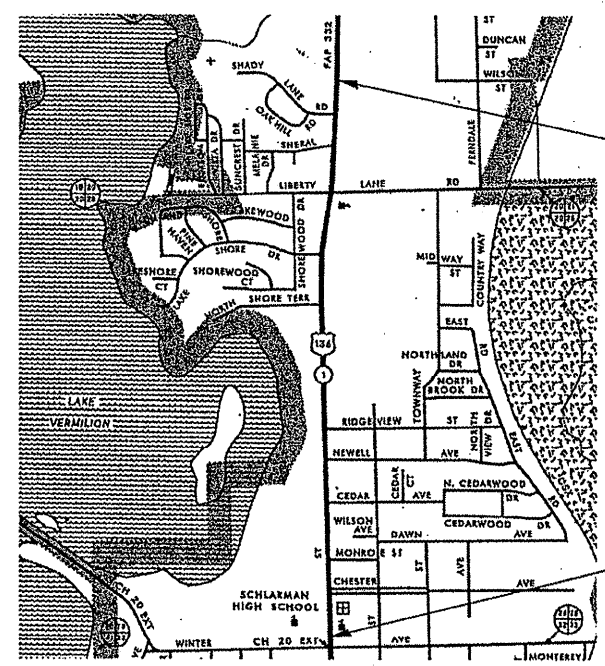

IMPROVEMENT ENDS
STATION 251+25.00

IMPROVEMENT BEGINS
STATION 183+00.00

DESIGN DESIGNATION
O.P.A.

ADT 28,000 (2003)

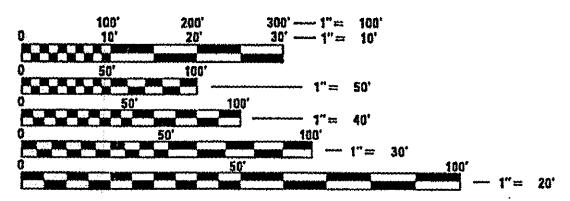

FULL SIZE PLANS HAVE BEEN PREPARED USING STANDARD ENGINEERING SCALES. REDUCED SIZED PLANS WILL NOT CONFORM TO STANDARD SCALES. IN MAKING MEASUREMENTS ON REDUCED PLANS, THE ABOVE SCALES MAY BE USED.

J.U.L.I.E.
JOINT UTILITY LOCATION INFORMATION FOR EXCAVATION
1-800-892-0123

CONTRACT NO. 70119

TOTAL LENGTH OF SECTION & PROJECT = 6,825.0 FEET = 1.293 MILES
NET LENGTH OF SECTION & PROJECT = 6,825.0 FEET = 1.293 MILES

STATE OF ILLINOIS
DEPARTMENT OF TRANSPORTATION
DIVISION OF HIGHWAYS

SUBMITTED 3/28 20 06
Joselyn E. Crowe
DEPUTY DIRECTOR OF HIGHWAYS, REGION 3 ENGINEER

May 12, 20 06
Mike Hene
ENGINEER OF DESIGN AND ENVIRONMENT

May 12, 20 06
Melton R. Sees PE
DIRECTOR OF HIGHWAYS, CHIEF ENGINEER

**PRINTED BY THE AUTHORITY
OF THE STATE OF ILLINOIS**

DESIGNER: RYAN CARROLL (217) 466-7216
PROJECT ENGINEER: KENSIL GARNETT (217) 466-7223
SQUAD LEADER: CORY SHEEHY (217) 466-7214

CONTRACT NO. 70119

F.A.P. RTE.	SECTION	COUNTY	TOTAL SHEETS	SHEET NO.
332	*	VERMILION	30	2
STA.		TO STA.		
FED. ROAD DIST. NO.		ILLINOIS FED. AID PROJECT		

*RX,4BZ-1RS-18&47R-1RS

INDEX OF SHEETS

- 1 COVER SHEET
- 2 INDEX OF SHEETS
- 3-4 GENERAL NOTES
- 5-6 SUMMARY OF QUANTITIES
- 7-8 EXISTING TYPICAL CROSS SECTIONS
- 9-10 PROPOSED TYPICAL CROSS SECTIONS
- 11-12 SCHEDULE OF QUANTITIES
- 13-14 TIE POINT LAYOUT
- 15-26 PAVEMENT MARKING & DETECTOR LOOP PLAN SHEETS
- 27-30 TYPICAL APPLICATION OF PAVEMENT MARKINGS

LIST OF STANDARDS

- 000001-04 STANARD SYMBOLS, ABBREVIATIONS, AND PATTERNS
- 001006 DECIMAL OF AN INCH AND OF A FOOT
- 442201-01 CLASS C & D PATCHES
- 701426-02 TRAFFIC CONTROL AND PROTECTION
- 701602-02 TRAFFIC CONTROL AND PROTECTION
- 701701-04 TRAFFIC CONTROL AND PROTECTION
- 702001-06 TRAFFIC CONTROL AND PROTECTION
- 780001-01 TYPICAL PAVEMENT MARKINGS
- 781001-02 TYPICAL APPLICATIONS RAISED REFLECTIVE PAVEMENT MARKERS
- 886001 DETECTOR LOOP INSTALLATIONS
- 886006 TYPICAL LAYOUT FOR DETECTION LOOPS

PLOT DATE = 2/24/2006
FILE NAME = c:\p2006\70119\15.dgn
USER NAME = eberrollr

F.A.P. RTE.	SECTION	COUNTY	TOTAL SHEETS	SHEET NO.
332	*	VERMILION	30	3
STA.		TO STA.		
FED. ROAD DIST. NO.		ILLINOIS FED. AID PROJECT		

*IRX,48Z-1RS-18147R-1RS

GENERAL NOTES

G. N. -100

ENGLISH UNITS OF MEASUREMENT SHALL GOVERN OVER AND SUPERSEDE ANY METRIC UNITS SHOWN IN THIS CONTRACT. WHERE INCLUDED, METRIC UNITS ARE FOR INFORMATION ONLY.

G. N. -406

THE QUANTITIES INCLUDED IN THE PLANS FOR BITUMINOUS CONCRETE RESURFACING ARE INTENDED TO GIVE THE COVERAGE SHOWN ON THE TYPICAL CROSS SECTIONS. IT IS NOT INTENDED TO INCREASE THE THICKNESS OF THE BITUMINOUS MIXTURE IN ORDER TO USE ALL OF THE QUANTITIES INCLUDED IN THE CONTRACT. DESIGN THICKNESS CAN BE BACK CALCULATED USING THE CONVERSION FACTOR OF 1IN THICKNESS = 112 POUNDS/SQUARE YARD.

G. N. 406D

ALL LEVELING BINDER OR BINDER SHALL BE GIVEN A FOG COAT OF PRIME BEFORE THE SURFACE COURSE IS PLACED WHEN DIRECTED BY THE ENGINEER.

THE FOG COAT WILL BE PAID FOR AT THE CONTRACT UNIT PRICE PER GALLON FOR BITUMINOUS MATERIAL (PRIME COAT) AND NO ADDITIONAL COMPENSATION WILL BE ALLOWED.

G. N. 406E

FOR MULTILANE RESURFACING.

WHEN BEGINNING THE RESURFACING WITH NEW MIXTURES FOR LEVELING BINDER, BINDER COURSE, AND SURFACE COURSE MIXTURES, THE WORK WILL BE CONFINED TO THE INSIDE TRAFFIC LANE (PASSING LANE) FIRST. THE WORK WILL REMAIN ON THE INSIDE LANE UNTIL THE MIX HAS BEEN ADJUSTED AND APPROVED BY THE ENGINEER BEFORE ANY RESURFACING IS ALLOWED ON THE OUTSIDE (DRIVING) TRAFFIC LANE(S).

ANY DELAYS OR INCONVENIENCES CAUSED THE CONTRACTOR IN COMPLYING WITH THIS REQUIREMENT WILL BE CONSIDERED INCIDENTAL TO THE VARIOUS CLASS I PAY ITEMS OR SUPERPAVE PAY ITEMS, AS SHOWN IN THE CONTRACT, AND NO ADDITIONAL COMPENSATION WILL BE ALLOWED.

G. N. 406H

MIXTURE REQUIREMENTS

The following mixture requirements are applicable for this project:

Location(s): Mixture Use(s):	POLYMER BIT CONC. SURF CSE, SUPERPAVE, MIX E, N90	POLYMER L.B. MM SUPERPAVE N90	CLASS D PATCHING
AC/PG:	SBS PG 70-22	SBS PG 70-22	PG 64-22
RAP %: (Max)**	0 %	0 %	10%
Design Air Voids:	4.0% @ 90 GYRATIONS	4.0% @ 90 GYRATIONS	4.0% @ 90 GYRATIONS
Mixture Composition: (Gradation Mixture)	IL 9.5 OR IL 12.5	IL 9.5	IL 19.0
Friction Aggregate:	E	C	N. A.

CONTRACT NO. 70119

F.A.P. RTE.	SECTION	COUNTY	TOTAL SHEETS	SHEET NO.
332	*	VERMILION	30	4
STA.		TO STA.		
FED. ROAD DIST. NO.		ILLINOIS FED. AID PROJECT		

*IRX,482-1RS-1&147R-1RS

GENERAL NOTES

G. N. -442B -- PATCHING SCHEDULES

THE PATCHING SCHEDULES INCLUDED IN THE PLANS REPRESENT THE BEST INFORMATION AVAILABLE AT THE TIME OF COMPLETION OF THE PLANS FOR LETTING. VARIATIONS IN LOCATION AND SIZES OF BOTH FULL-DEPTH AND PARTIAL-DEPTH PATCHES MAY OCCUR.

G. N. -667

THE RESIDENT ENGINEER SHALL CONTACT THE PROGRAM DEVELOPMENT CHIEF OF SURVEYS PRIOR TO THE PRE-CONSTRUCTION CONFERENCE FOR INSTRUCTION AS TO SETTING OF TEMPORARY OR PERMANENT TIES FOR CENTERLINE ALIGNMENT CONTROL SURVEY MARKERS (PC•S, PT•S, AND PI•S). PROJECT IMPLEMENTATION PERSONNEL WILL BE RESPONSIBLE FOR SETTING THESE MARKERS.

G. N. -703A

SHORT TERM PAVEMENT MARKING SHALL BE APPLIED TO THE PAVEMENT AFTER ANY OF THE FOLLOWING: COLD MILLING AND/OR PLACING BITUMINOUS MATERIALS (PRIME COAT), LEVELING BINDER (MACHINE METHOD), BINDER AND SURFACE COURSES. SHORT TERM PAVEMENT MARKING PLACED ON THE SURFACE, SHALL COINCIDE WITH THE FINAL PAVEMENT STRIPING. SHORT TERM PAVEMENT MARKING PLACED PRIOR TO THE SURFACE SHALL COINCIDE WITH THE EXISTING PAVEMENT MARKINGS. USE 4 FEET PER 40 FEET (OR 10% PER STATION).

G. N. -781

RAISED REFLECTIVE PAVEMENT MARKERS SHALL BE PLACED IN ACCORDANCE WITH STANDARD 781001, AND THE DETAILS SHOWN IN THE PLANS. IF THERE IS ANY DISCREPENCY BETWEEN THE STANDARD AND THE DETAILS IN THE PLANS, THE DETAILS IN THE PLANS SHALL GOVERN. THE FINAL PAVEMENT MARKINGS SHALL BE IN PLACE PRIOR TO PLACING THE RAISED REFLECTIVE PAVEMENT MARKERS AND THE RAISED REFLECTIVE PAVEMENT MARKERS SHALL BE PLACED MIDWAY IN THE 9 m (30 FOOT) SPACE BETWEEN THE DASHED CENTERLINE STRIPES (WHEN APPLICABLE).

G. N. • 873

EXISTING DETECTOR LOOPS IN THE AREAS OF PROPOSED SURFACE REMOVAL SHALL BE REPLACED PER THE EXISTING SIZE AND LOCATION EXCEPT AS NOTED IN THE PLANS. EXISTING DETECTOR LOOPS SHALL BE DISCONNECTED AT THE GULFBOX JUNCTION OR HANDHOLE PRIOR TO COLD MILLING AT THAT RESPECTIVE LOCATION. NEW DETECTOR LOOPS SHALL BE CONNECTED TO THE RESPECTIVE EXISTING AMPLIFIER. IN GENERAL, ADVANCED DETECTOR LOOPS FOR DILEMMA ZONE PROTECTION LOCATED AT THE SAME STATION SHALL BE GROUPED TOGETHER ON A COMMON AMPLIFIER. PRESENCE LOOPS SHALL BE GROUPED BY LANE ON A COMMON AMPLIFIER.

WHERE IT IS NECESSARY TO INSTALL MORE THAN ONE LOOP HOMERUN IN A CONDUIT, HOMERUNS SHARING THE SAME CONDUIT SHALL BE ON A COMMON AMPLIFIER.

70119

SUMMARY OF QUANTITIES

CONTRACT NO. 70119

F.A.P. RTE.	SECTION	COUNTY	TOTAL SHEETS	SHEET NO.
332	*	VERMILION	30	5
STA.		TO STA.		
FED. ROAD DIST. NO.	ILLINOIS	FED. AID PROJECT		

*IRX,4BZ-1RS-1&4TR-1RS

LOCATION OF WORK:

FAP 332 (US136/IL1)
STA. 183+00 TO 251+25

URBAN

80% FEDERAL
20% STATE

CONSTRUCTION TYPE CODE:

1000

TOTAL
QUANTITY

CODE NO	ITEM	UNIT	TOTAL QUANTITY
40600100	BITUMINOUS MATERIALS (PRIME COAT)	GALLON	9,066.0
40600300	AGGREGATE (PRIME COAT)	TON	182.0
40600895	CONSTRUCTING TEST STRIP	EACH	1.0
40600990	TEMPORARY RAMP	SQ YD	65.0
44201777	CLASS D PATCH, TYPE II, 11 INCH	SQ YD	26.7
44201781	CLASS D PATCH, TYPE III, 11 INCH	SQ YD	16.0
44201798	CLASS D PATCH, TYPE I, 13 INCH	SQ YD	8.0
44201803	CLASS D PATCH, TYPE II, 13 INCH	SQ YD	10.7
67000400	ENGINEER'S FIELD OFFICE, TYPE A	CAL MO	4.0
67100100	MOBILIZATION	L SUM	1.0
70102632	TRAFFIC CONTROL AND PROTECTION, STANDARD 701602	L SUM	1.0
70102635	TRAFFIC CONTROL AND PROTECTION, STANDARD 701701	L SUM	1.0
70300100	SHORT-TERM PAVEMENT MARKING	FOOT	5,460.0
70300610	TEMPORARY PAINT PAVEMENT MARKING, LETTERS AND SYMBOLS	SQ FT	1,357.0
70300625	TEMPORARY PAINT PAVEMENT MARKING LINE 4"	FOOT	17,423.0
70300635	TEMPORARY PAINT PAVEMENT MARKING LINE 6"	FOOT	1,219.0
70300660	TEMPORARY PAINT PAVEMENT MARKING LINE 24"	FOOT	375.0

70119

SUMMARY OF QUANTITIES

CONTRACT NO. 70119				
F.A.P. RTE.	SECTION	COUNTY	TOTAL SHEETS	SHEET NO.
332	*	VERMILION	30	6
STA.		TO STA.		
FED. ROAD DIST. NO.	ILLINOIS	FED. AID PROJECT		
*RX,482-1RS-18(47R-1)RS				

LOCATION OF WORK:

FAP 332 (US136/IL1)
STA. 183+00 TO 251+25

URBAN
80% FEDERAL
20% STATE

CONSTRUCTION TYPE CODE:

1000
TOTAL
QUANTITY

CODE NO	ITEM	UNIT	QUANTITY
70301000	WORK ZONE PAVEMENT MARKING REMOVAL	SQ FT	1,802.0
* 78000100	THERMOPLASTIC PAVEMENT MARKING - LETTERS AND SYMBOLS	SQ FT	1,357.0
* 78000200	THERMOPLASTIC PAVEMENT MARKING - LINE 4"	FOOT	17,423.0
* 78000400	THERMOPLASTIC PAVEMENT MARKING - LINE 6"	FOOT	1,219.0
* 78000650	THERMOPLASTIC PAVEMENT MARKING - LINE 24"	FOOT	375.0
* 78100100	RAISED REFLECTIVE PAVEMENT MARKER	EACH	563.0
78300200	RAISED REFLECTIVE PAVEMENT MARKER REMOVAL	EACH	563.0
* 88600100	DETECTOR LOOP, TYPE I	FOOT	2,561.0
X4066538	POLYMERIZED BITUMINOUS CONCRETE SURFACE COURSE, SUPERPAVE, MIX "E", N90	TON	3,808.0
X4066915	POLYMERIZED LEVELING BINDER (MACHINE METHOD), SUPERPAVE N90	TON	2,538.0
X4409410	BITUMINOUS SURFACE REMOVAL 2 1/4"	SQ YD	45,329.0
X7015005	CHANGEABLE MESSAGE SIGN	CAL DAY	14.0

* SPECIALTY ITEMS

CONTRACT NO. 70119				
F.A.P. RTE.	SECTION	COUNTY	TOTAL SHEETS	SHEET NO.
332		VERMILION	30	7
STA.		TO STA.		
FED. ROAD DIST. NO.		ILLINOIS FED. AID PROJECT		
•(RX,482-11RS-1&147R-1RS				

① EXISTING TYPICAL CROSS SECTION

① STATION 183+00.00 TO STATION 203+00.00 ②

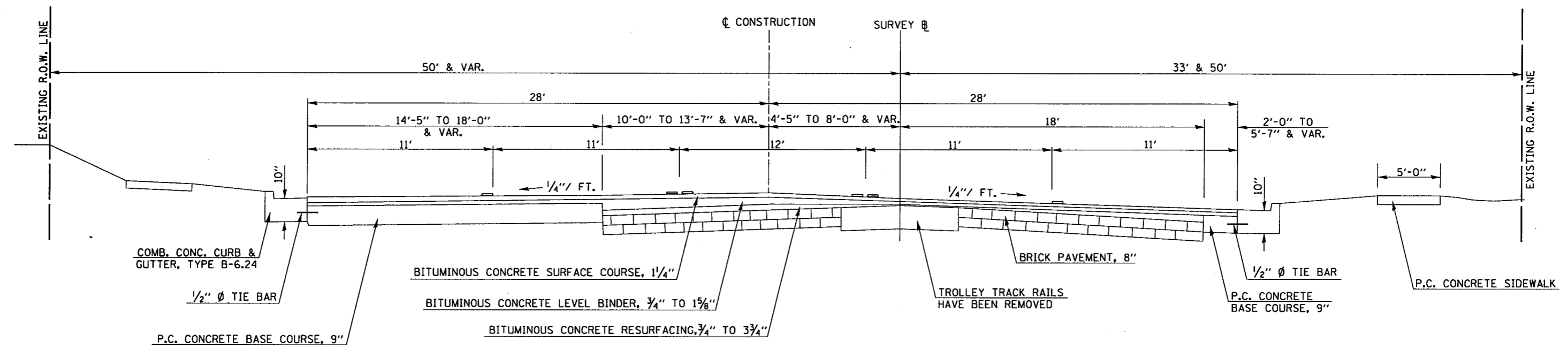

② EXISTING TYPICAL CROSS SECTION

① STATION 203+00.00 TO STATION 211+00.00 ③

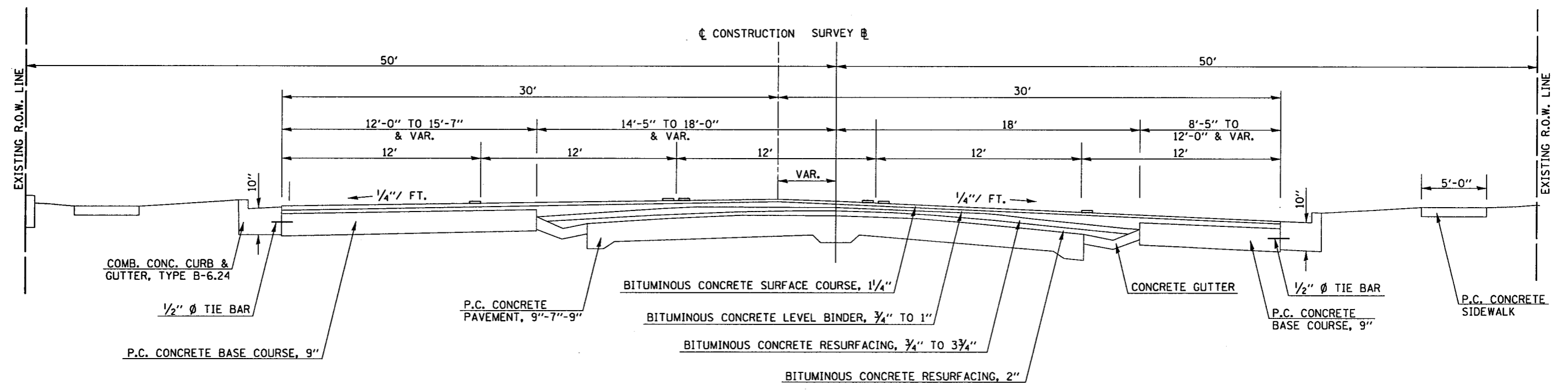

PLOT DATE: 11/15/01
 FILE NAME: 111111.DWG
 USER: JMM

F.A.P. RTE.	SECTION	COUNTY	TOTAL SHEETS	SHEET NO.
332		VERMILION	30	8
STA.	TO STA.			
FED. ROAD DIST. NO.	ILLINOIS FED. AID PROJECT			

(RX,48Z-1RS-1&(47R-1RS

③ EXISTING TYPICAL CROSS SECTION

- ② STATION 211+00.00 TO STATION 216+71.93 ④
- ④ STATION 241+12.11 TO STATION 251+25.00

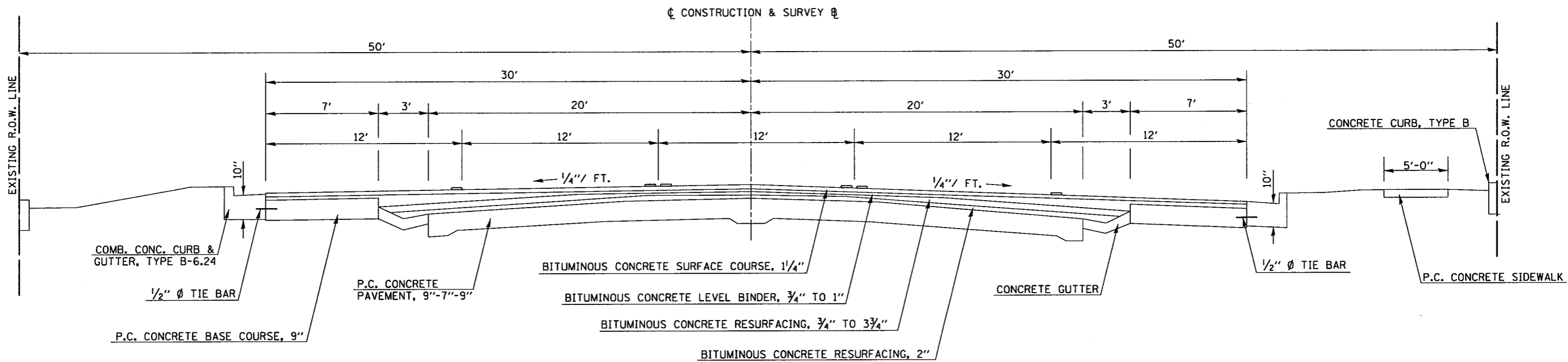

④ EXISTING TYPICAL CROSS SECTION

- ③ STATION 216+71.93 TO STATION 241+12.11 ③

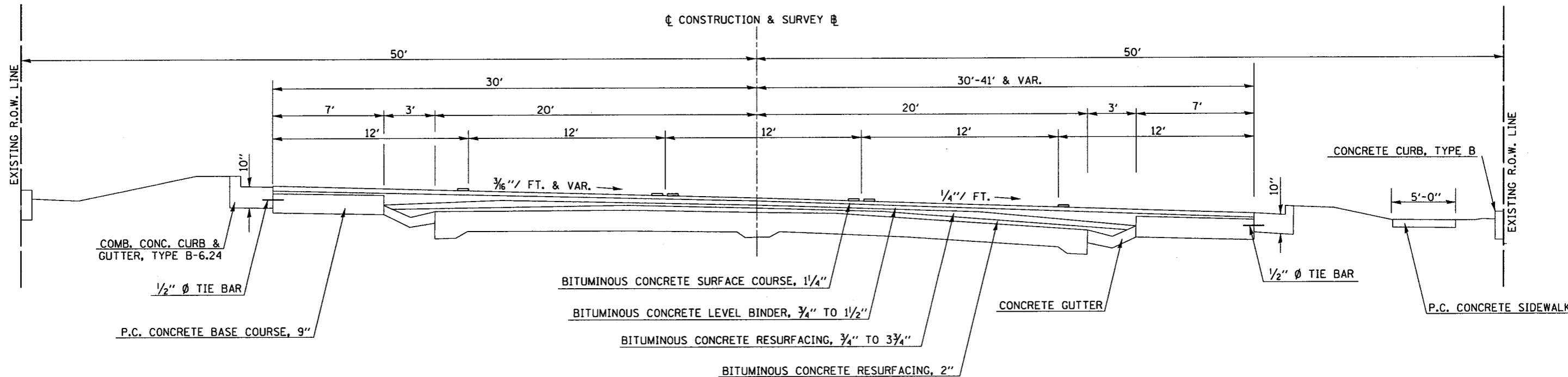

PLOT DATE = 3/24/2006
 FILE NAME = n:\p\m\m\681988 (v81)\g\o\l\l.dgn
 PLOT SCALE = 43.285' / IN.
 USER NAME = carrollr

F.A.P. RTE.	SECTION	COUNTY	TOTAL SHEETS	SHEET NO.
332		VERMILION	30	9
STA.	TO STA.			
FED. ROAD DIST. NO.	ILLINOIS	FED. AID PROJECT		

*RX,482-1RS-1&(47R-1RS

① PROPOSED TYPICAL CROSS SECTION

① STATION 183+00.00 TO STATION 203+00.00 ②

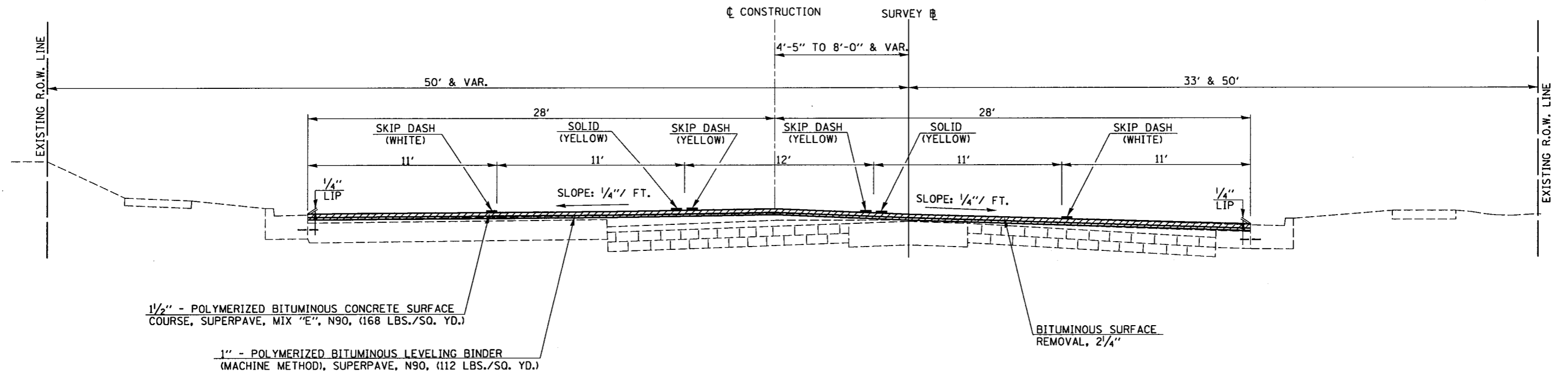

② PROPOSED TYPICAL CROSS SECTION

① STATION 203+00.00 TO STATION 211+00.00 ③

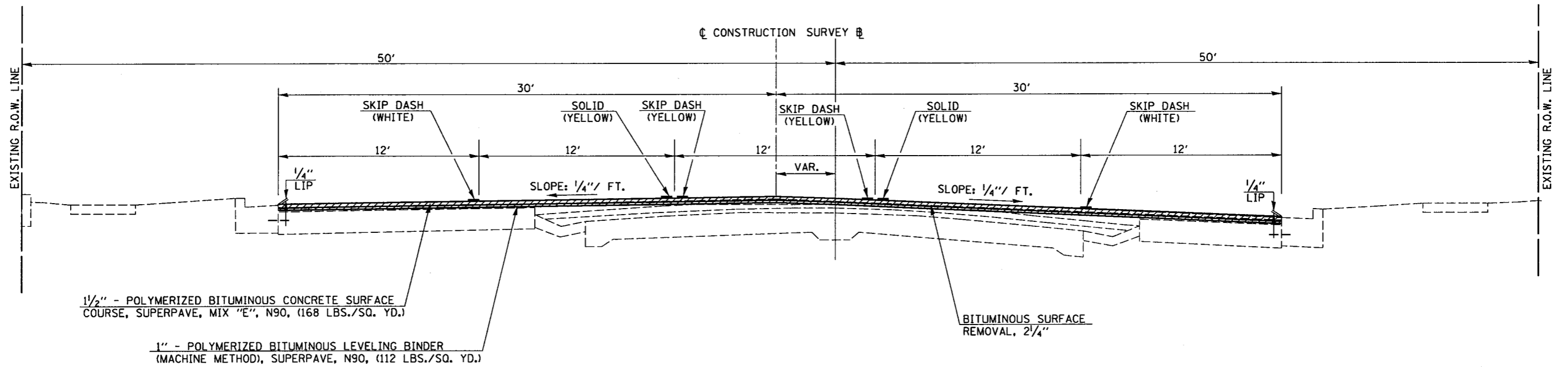

F.A.P. RTE.	SECTION	COUNTY	TOTAL SHEETS	SHEET NO.
332		VERMILION	30	10
STA.		TO STA.		
FED. ROAD DIST. NO.		ILLINOIS FED. AID PROJECT		

•(RX,482-11RS-18(47R-1)RS

③ PROPOSED TYPICAL CROSS SECTION

② STATION 211+00.00 TO STATION 216+71.93 ④

④ STATION 241+12.11 TO STATION 251+25.00

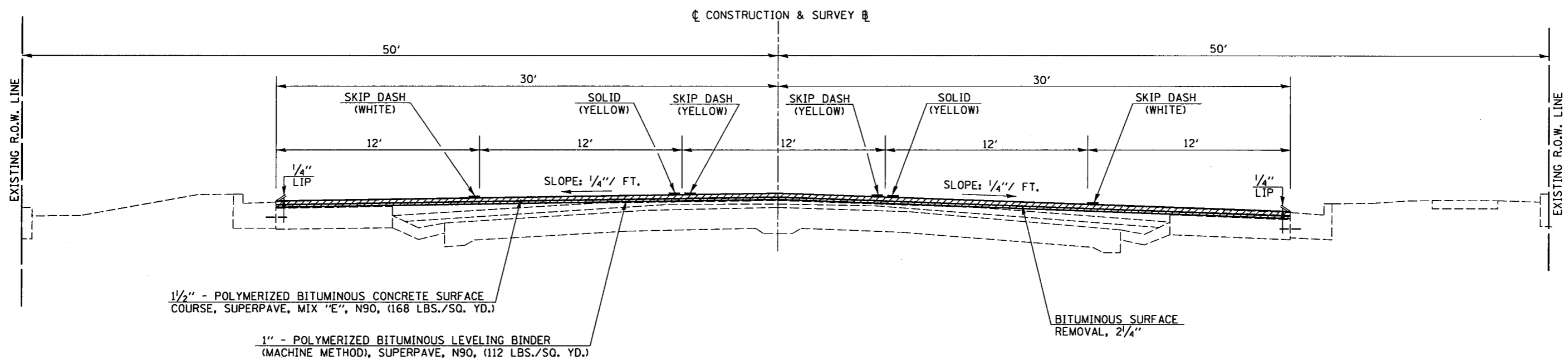

④ PROPOSED TYPICAL CROSS SECTION

③ STATION 216+71.93 TO STATION 241+12.11 ③

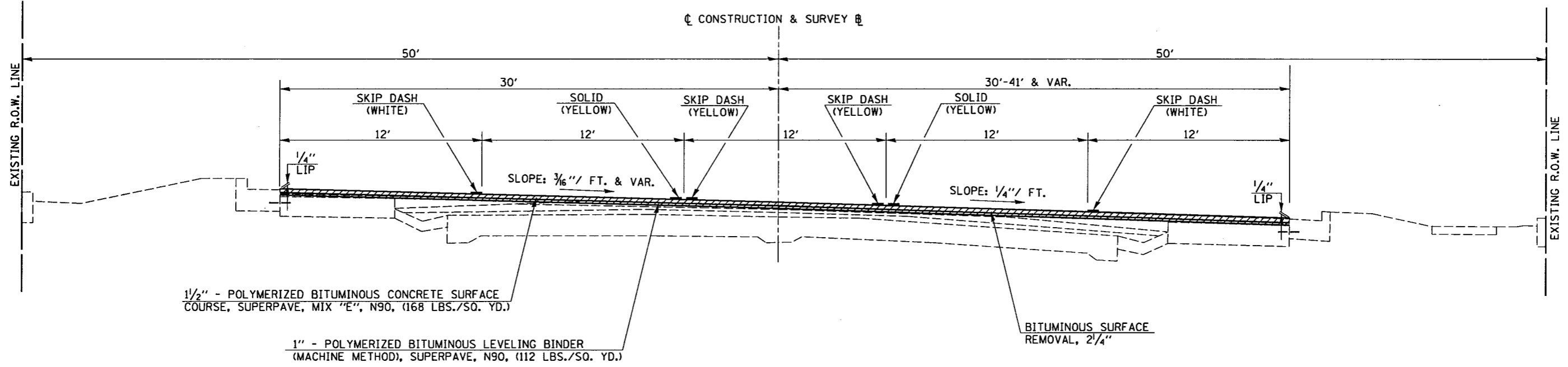

PLOT DATE = 3/24/2006
 FILE NAME = c:\projects\70119\70119.dwg
 PLOT SCALE = 1/8" = 1'-0"
 USER NAME = carrollr

SCHEDULE OF QUANTITIES

F.A.P. RTE.	SECTION	COUNTY	TOTAL SHEETS	SHEET NO.
332	*	VERMILION	30	11
STA.		TO STA.		
FED. ROAD DIST. NO.		ILLINOIS FED. AID PROJECT		

* (RX, 482-1)RS-1&(47R-1)RS

THERMOPLASTIC PAVEMENT MARKING - 4" YELLOW (SKIP-DASH)

STA.	TO	STA.	S.B. O/S	&	N.B. O/S	FOOT
183+00		184+28	5.5' LT*	&	5.5' RT*	60
185+17		187+53	5.5' LT*	&	5.5' RT*	120
188+26		188+61	5.5' LT*	&	5.5' RT*	20
191+26		194+64	5.5' LT*	&	5.5' RT*	180
195+36		199+62	5.5' LT*	&	5.5' RT*	220
200+82		203+31	5.5' LT*	&	5.5' RT*	140
204+29		210+04	5.5' LT*	&	5.5' RT*	300
214+39		218+65	5.5' LT	&	5.5' RT	220
219+32		222+58	5.5' LT	&	5.5' RT	160
226+94		230+43	5.5' LT	&	5.5' RT	180
234+72		238+26	5.5' LT	&	5.5' RT	180
239+23		240+52	5.5' LT	&	5.5' RT	60
244+93		251+25	5.5' LT	&	5.5' RT	320
TOTAL =						2,160

* - O/S TO CONSTRUCTION CENTER LINE

THERMOPLASTIC PAVEMENT MARKING - 4" YELLOW (SOLID)

STA.	TO	STA.	S.B. O/S	&	N.B. O/S	FOOT
183+00		184+28	6' LT*	&	6' RT*	256
185+17		187+53	6' LT*	&	6' RT*	472
188+26		188+61	6' LT*	&	6' RT*	70
191+26		194+64	6' LT*	&	6' RT*	676
195+36		199+62	6' LT*	&	6' RT*	852
200+82		203+31	6' LT*	&	6' RT*	498
204+29		210+04	6' LT*	&	6' RT*	1150
214+39		218+65	6' LT	&	6' RT	852
219+32		222+58	6' LT	&	6' RT	652
226+94		230+43	6' LT	&	6' RT	698
234+72		238+26	6' LT	&	6' RT	708
239+23		240+52	6' LT	&	6' RT	258
244+93		251+25	6' LT	&	6' RT	1264
TOTAL =						8,406

* - O/S TO CONSTRUCTION CENTER LINE

THERMOPLASTIC PAVEMENT MARKING - 4" YELLOW (DOUBLE)

STA.	TO	STA.	O/S	FOOT
188+61		190+19	6' LT*	316
210+04		211+62	6' LT* TO 6' LT	316
212+81		214+39	6' RT	316
222+58		224+16	6' LT	316
225+36		226+94	6' RT	316
230+43		232+01	6' LT	316
233+14		234+72	6' RT	316
240+52		242+10	6' LT	316
243+35		244+93	6' RT	316
TOTAL =				2,844

* - O/S TO CONSTRUCTION CENTER LINE

THERMOPLASTIC PAVEMENT MARKING - 4" WHITE (SKIP-DASH)

STA.	TO	STA.	S.B. O/S	&	N.B. O/S	FOOT
183+00		184+28	17' LT*	&	17' RT*	60
185+17		187+53	17' LT*	&	17' RT*	120
188+26		190+19	17' LT*	&	17' RT*	100
191+26		194+64	17' LT*	&	17' RT*	180
195+36		199+62	17' LT*	&	17' RT*	220
200+82		203+31	17' LT* TO 18' LT*	&	17' RT* TO 18' RT*	140
204+29		211+62	18' LT* TO 18' LT	&	18' RT* TO 18' RT	380
212+81		218+65	18' LT	&	18' RT	300
219+32		224+16	18' LT	&	18' RT	240
225+36		232+01	18' LT	&	18' RT	340
233+14		238+26	18' LT	&	18' RT	260
239+23		242+10	18' LT	&	18' RT	140
243+35		251+25	18' LT	&	18' RT	400
TOTAL =						2,880

* - O/S TO CONSTRUCTION CENTER LINE

THERMOPLASTIC PAVEMENT MARKING - 4" WHITE (SOLID)

STA.	TO	STA.	O/S	FOOT
189+21		190+19	6' RT	98
210+24		211+40	30' RT	115
210+64		211+62	6' RT	98
212+81		213+79	6' LT	98
222+80		224+16	30' RT	136
223+18		224+16	6' RT	98
223+36		224+34	6' LT	98
231+03		232+01	6' RT	98
233+14		234+12	6' LT	98
241+12		242+10	6' RT	98
243+35		244+33	6' LT	98
TOTAL =				1,133
GRAND TOTAL =				17,423

* - O/S TO CONSTRUCTION CENTER LINE

SCHEDULE OF QUANTITIES

F.A.P. RTE.	SECTION	COUNTY	TOTAL SHEETS	SHEET NO.
332	*	VERMILION	30	12
STA.		TO STA.		
FED. ROAD DIST. NO.	ILLINOIS	FED. AID PROJECT		

*RX, 4BZ-1RS-1&(47R-1RS)

THERMOPLASTIC PAVEMENT MARKING LINE - 6" WHITE (CROSS WALK)

STA.	S.B. O/S	N.B. O/S	FOOT
190+25	28' LT*	28' RT*	56
190+31	28' LT*	28' RT*	56
211+68	30' LT	42' RT	72
211+74	30' LT	45' RT	75
212+69	30' LT	45' RT	75
212+75	30' LT	42' RT	72
224+22	30' LT	43' RT	73
224+28	32' LT	44' RT	76
225+24	32' LT	42' RT	74
225+30	30' LT	40' RT	70
232+07	32' LT	32' RT	64
232+13	34' LT	34' RT	68
233+02	34' LT	34' RT	68
233+08	32' LT	32' RT	64
242+16	32' LT	32' RT	64
242+22	32' LT	32' RT	64
243+13	32' LT	32' RT	64
243+19	32' LT	32' RT	64
TOTAL =			1219

* - O/S TO CONSTRUCTION CENTER LINE

THERMOPLASTIC PAVEMENT MARKING LINE - 24" WHITE (STOP BAR)

STA.	O/S	TO	O/S	FOOT
190+21	6' LT*	28' RT*		34
191+24	6' RT*	28' LT*		34
224+18	6' LT	42' RT		48
225+34	30' LT	6' RT		36
232+03	6' LT	31' RT		37
233+12	31' LT	6' RT		37
211+64	6' LT	35' RT		41
212+79	30' LT	6' RT		36
242+12	6' LT	30' RT		36
243+33	6' RT	30' LT		36
TOTAL =				375

* - O/S TO CONSTRUCTION CENTER LINE

THERMOPLASTIC PAVEMENT MARKINGS - LETTERS & SYMBOLS

LEFT TURN ARROWS

STA.	SQ. FT.	O/S
189+21	15.6	0*
190+01	15.6	0*
210+64	15.6	0*
211+44	15.6	0'
212+99	15.6	0'
213+79	15.6	0'
223+18	15.6	0'
223+98	15.6	0'
225+54	15.6	0'
226+34	15.6	0'
231+03	15.6	0'
231+83	15.6	0'
233+32	15.6	0'
234+12	15.6	0'
241+12	15.6	0'
241+92	15.6	0'
243+53	15.6	0'
244+33	15.6	0'
TOTAL =		280.8

* - O/S TO CONSTRUCTION CENTER LINE

RIGHT TURN ARROWS

STA.	SQ. FT.	O/S
210+24	15.6	0*
210+74	15.6	0*
222+80	15.6	0'
223+39	15.6	0'
223+98	15.6	0'
TOTAL =		78.0

* - O/S TO CONSTRUCTION CENTER LINE

DUAL LEFT TURN ARROWS

STA.	SQ. FT.	O/S
183+98	31.2	0*
185+47	31.2	0*
187+23	31.2	0*
191+56	31.2	0*
192+95	31.2	0*
194+34	31.2	0*
195+66	31.2	0*
197+49	31.2	0*
199+32	31.2	0*
201+12	31.2	0*
203+01	31.2	0*
204+59	31.2	0*
206+31	31.2	0*
208+03	31.2	0*
209+75	31.2	0*
214+69	31.2	0'
216+52	31.2	0'
218+35	31.2	0'
219+62	31.2	0'
220+95	31.2	0'
222+28	31.2	0'
227+24	31.2	0'
228+69	31.2	0'
230+13	31.2	0'
235+02	31.2	0'
236+49	31.2	0'
237+96	31.2	0'
239+53	31.2	0'
245+23	31.2	0'
247+14	31.2	0'
249+05	31.2	0'
250+95	31.2	0'
TOTAL =		998.4

GRAND TOTAL = 1,357

* - O/S TO CONSTRUCTION CENTER LINE

DETECTOR LOOP, TYPE 1

LOCATION	FOOT	
CARLE CLINIC ENTRANCE**	366	
K-MART PLAZA ENTRANCE**	454	
LAKE SHORE & VILLAGE MALL ENTRANCE**	507	
LIBERTY LANE**	633	
SHADY LANE ROAD**	601	
TOTAL =		2,561

**SEE PLAN SHEETS FOR MORE DETAIL

CLASS D PATCHING SCHEDULE

STATION	DIRECTION	LANE	LENGTH	WIDTH	DEPTH	PATCH AREA		
						TYPE I	TYPE II	TYPE III
			(FT)	(FT)	(FT)	(SQ YD)	(SQ YD)	(SQ YD)
191+99	SB	DL	8	12	11	0.0	10.7	0.0
191+99	SB	PL	8	12	13	0.0	10.7	0.0
197+65	SB	DL	6	12	11	0.0	8.0	0.0
197+65	SB	PL	6	6	13	4.0	0.0	0.0
197+87	SB	DL	6	12	11	0.0	8.0	0.0
197+87	SB	PL	6	6	13	4.0	0.0	0.0
223+47	SB	DL	12	12	11	0.0	0.0	16.0
TOTALS =						8.0	37.3	16.0
						(SQ YD)	(SQ YD)	(SQ YD)

TIE POINT LAYOUT

CONTRACT NO. 70119

F.A.P. RTE.	SECTION	COUNTY	TOTAL SHEETS	SHEET NO.
332		VERMILION	30	13
STA.		TO STA.		
FED. ROAD DIST. NO.		ILLINOIS FED. AID PROJECT		

(RX,48Z-1)RS-1 & (47R-1)RS
FIRST MIDWEST BANK

P.O.T. #7 195+38.15

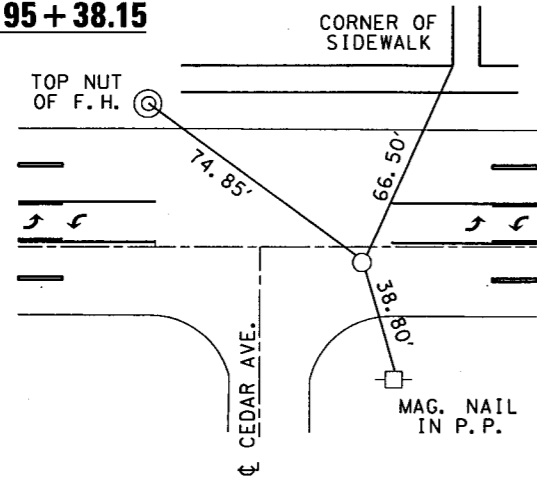

P.O.T. #8 208+26.62

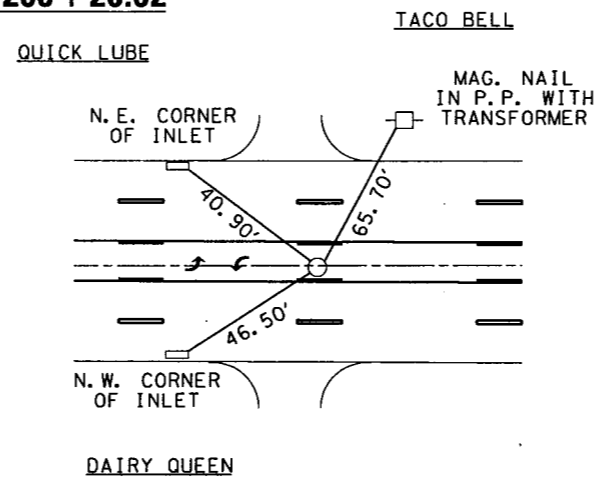

P.O.T. #20 215+41.76

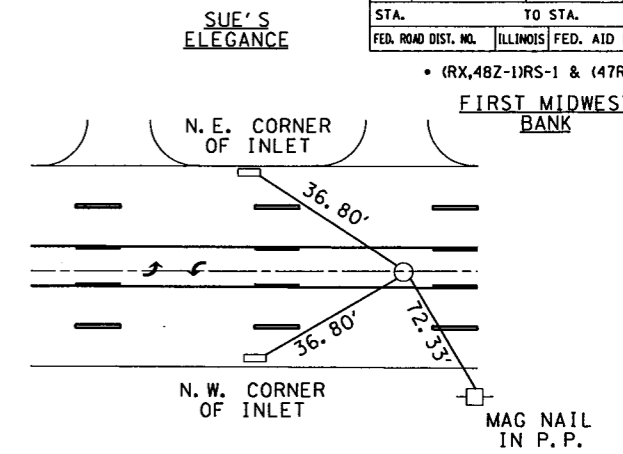

P.C. 218+21.96

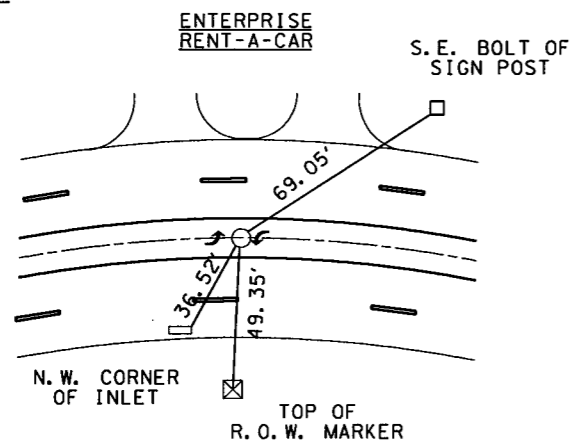

P.I. #50 223+61.96, -24.29
P.I. IS 0.78' S. OF VAULT

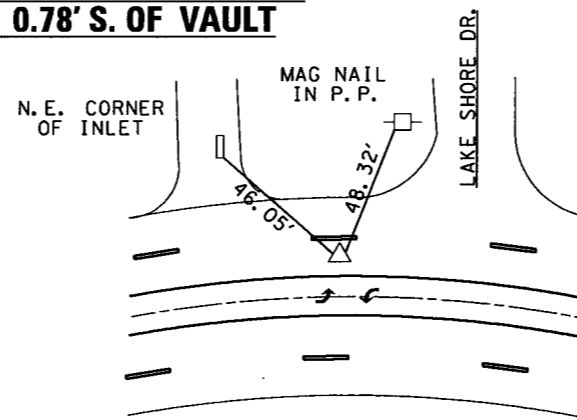

P.T. 228+99.05

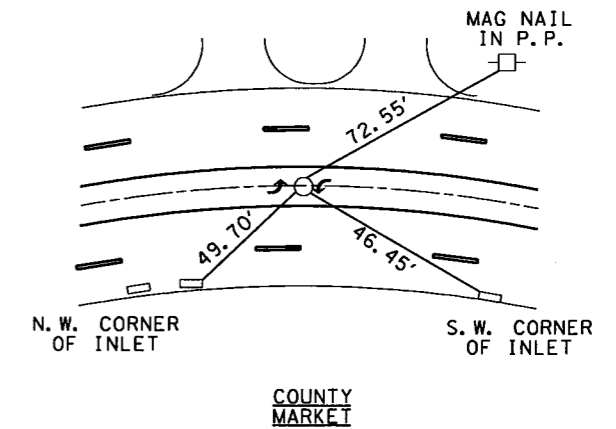

P.C. 231+63.22

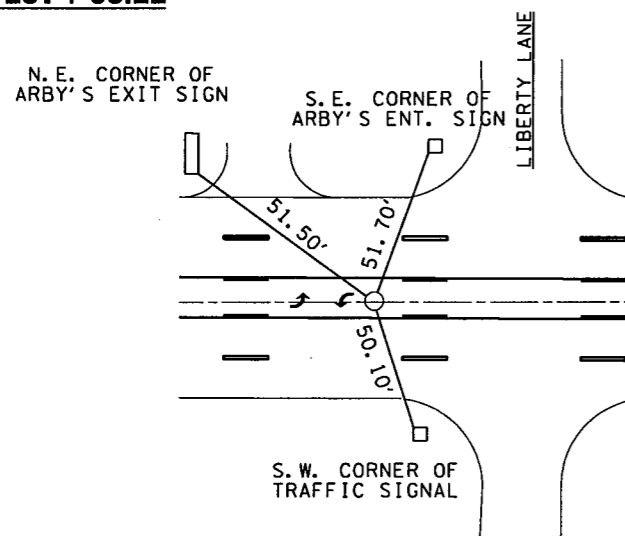

P.I. #25 235+63.22, 13.32 RT

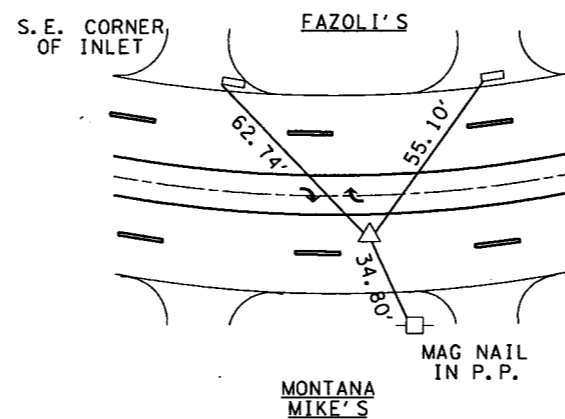

P.T. 239+62.04

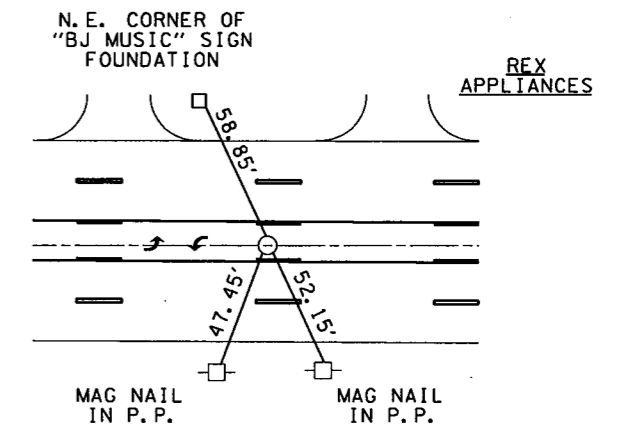

TIE POINT LAYOUT

CONTRACT NO. 70119

F.A.P. RTE.	SECTION	COUNTY	TOTAL SHEETS	SHEET NO.
332	.	VERMILION	30	14
STA.		TO STA.		
FED. ROAD DIST. NO.		ILLINOIS FED. AID PROJECT		

• (RX,48Z-1)RS-1 & (47R-1)RS

P.O.T. #27 246+07.62

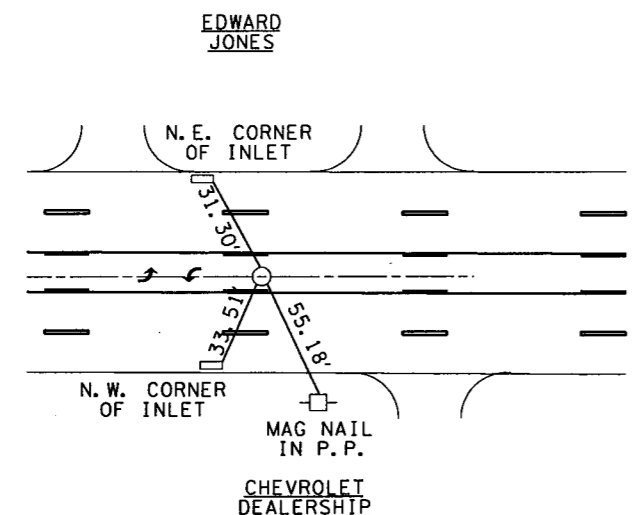

P.C. 247+93.12

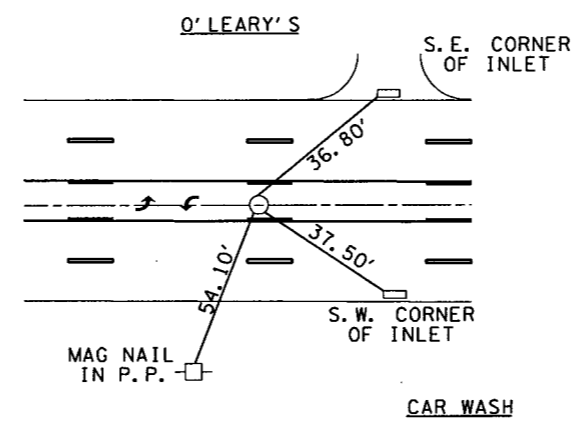

P.I. # 29 252+93.12, 0.73' LT

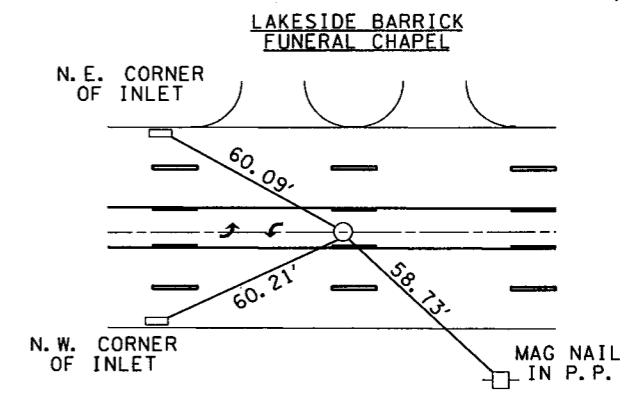

P.T. 257+93.12

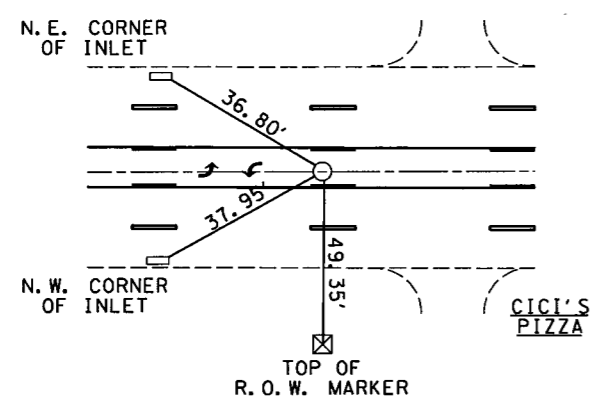

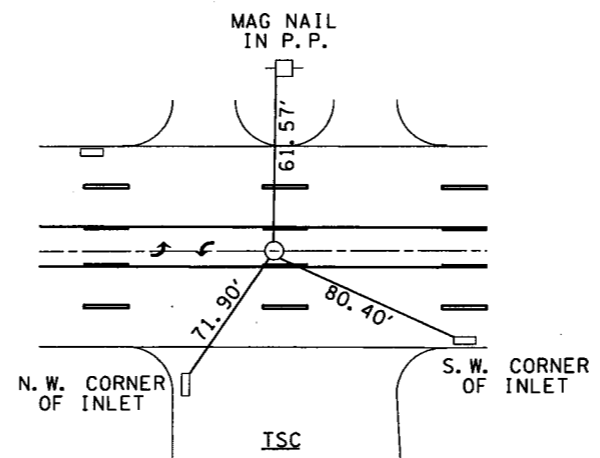

P.I. #31 277+01.41



PLOT DATE = 3/24/2006
 FILE NAME = c:\projects\2004\900\td\tdetail.dgn
 PLOT SCALE = 43.295' / IN.
 USER NAME = carrollt

F.A.P. RTE.	SECTION	COUNTY	TOTAL SHEETS	SHEET NO.
332	*	VERMILION	30	15
STA. 183+00		TO STA. 188+00		
FED. ROAD DIST. NO.		ILLINOIS FED. AID PROJECT		
*(RX,48Z-1)RS-1 & (47R-1)RS				

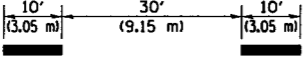
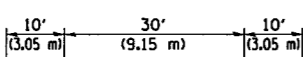
TYPICAL PAVEMENT MARKING LEGEND

- 1 4" (100) SKIP-DASH (YELLOW) 
- 2 4" (100) SOLID (YELLOW) 
- 7 4" (100) SKIP-DASH (WHITE) 



STA. 184+72.50 (US 136) =
STA. 10+00.00 (CHESTER AVE.)

STA. 187+88.19 (US 136) =
STA. 400+00.00 (MONROE ST.)

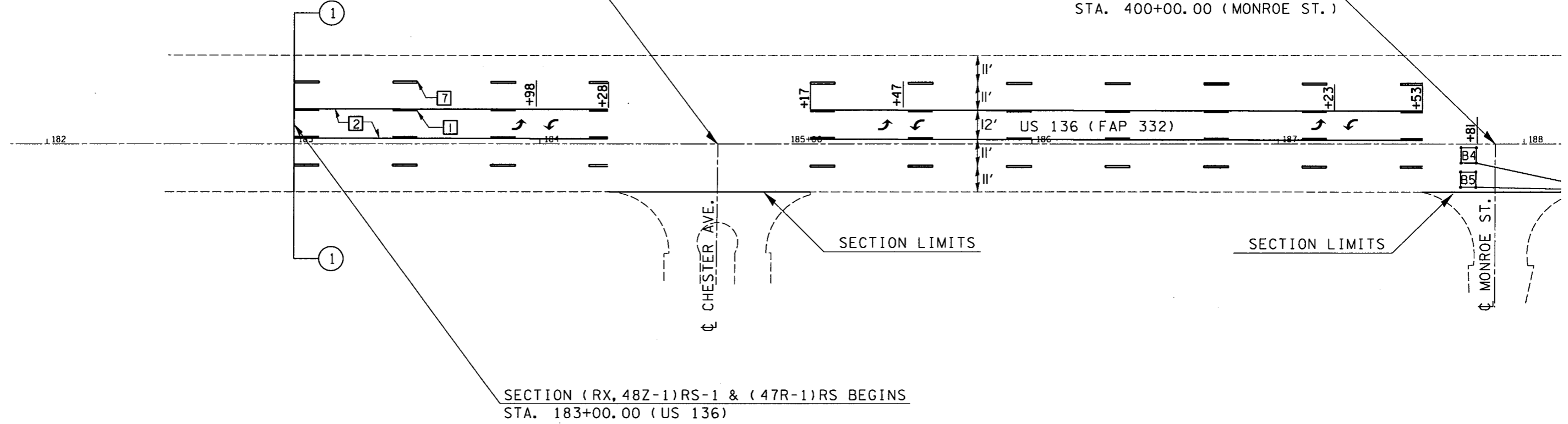

SECTION (RX, 48Z-1)RS-1 & (47R-1)RS BEGINS
STA. 183+00.00 (US 136)

PLOT DATE = 3/25/2006
 PLOT SCALE = 43.2000" / ft.
 USER NAME = carrollt

REVISIONS	
NAME	DATE

ILLINOIS DEPARTMENT OF TRANSPORTATION

PAVEMENT MARKING &
DETECTOR LOOP PLANS

SCALE: VERT. _____
HORIZ. _____

DATE _____ DRAWN BY _____
CHECKED BY _____

F.A.P. RTE.	SECTION	COUNTY	TOTAL SHEETS	SHEET NO.
332	*	VERMILION	30	16
STA. 188+00		TO STA. 193+00		
FED. ROAD DIST. NO.		ILLINOIS FED. AID PROJECT		

(RX,482-1)RS-1 & (47R-1)RS

TYPICAL PAVEMENT MARKING LEGEND

- 1 4" (100) SKIP-DASH (YELLOW)
- 2 4" (100) SOLID (YELLOW)
- 4 4" (100) DOUBLE YELLOW (NARROW)
- 7 4" (100) SKIP-DASH (WHITE)
- 8 4" (100) SOLID (WHITE)
- 10 6" (150) CROSS WALK (WHITE)
- 11 24" (600) STOP BAR (WHITE)

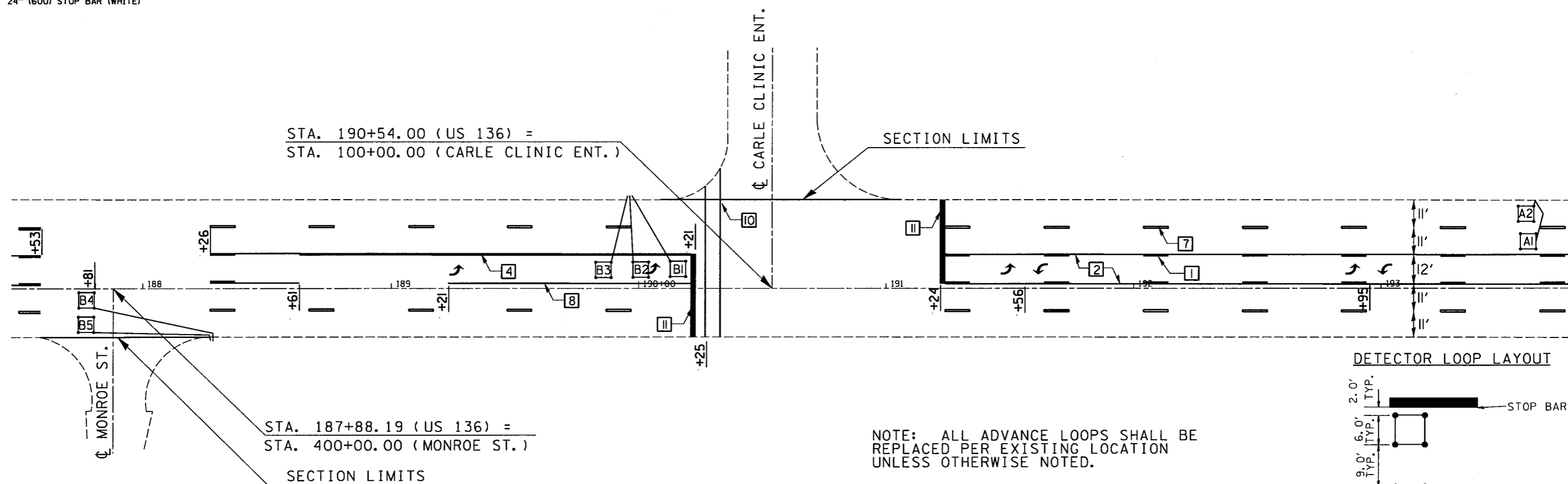

DETECTOR LOOP LAYOUT

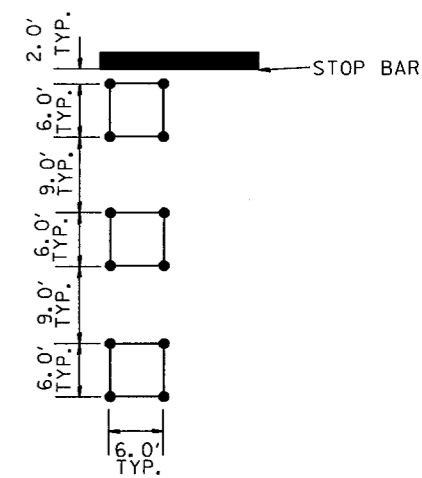

NOTE: ALL ADVANCE LOOPS SHALL BE REPLACED PER EXISTING LOCATION UNLESS OTHERWISE NOTED.

DETECTOR LOOP DATA

IL. RTE. 1 & CARLE CLINIC ENT.

LOOP	SIZE	TURNS
A1-2	6' X 6'	4
B1-3	6' X 6'	4
B4-5	6' X 6'	6

DETAIL OF DETECTOR LOOP WIRING

WIRED IN SERIES WITH MULTI-PAIR CABLE

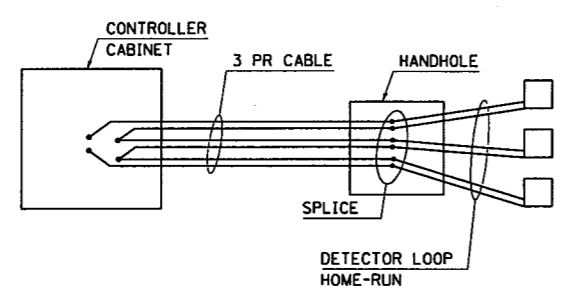

The existing detector loop lead-in cable is:

No. 18, 3pr., Lead-In

REVISIONS	
NAME	DATE

ILLINOIS DEPARTMENT OF TRANSPORTATION

PAVEMENT MARKING & DETECTOR LOOP PLANS

SCALE: VERT. HORIZ. DATE

DRAWN BY CHECKED BY

PLOT DATE = 3/28/2006
 FILE NAME = c:\pavement\70119\16.dwg
 USER NAME = c:\pavement\70119\16.dwg

F.A.P. RTE.	SECTION	COUNTY	TOTAL SHEETS	SHEET NO.
332	*	VERMILION	30	17
STA. 193+00		TO STA. 199+00		
FED. ROAD DIST. NO.		ILLINOIS FED. AID PROJECT		
*RX, 48Z-1RS-1 & (47R-1)RS				

TYPICAL PAVEMENT MARKING LEGEND

- 1 4" (100) SKIP-DASH (YELLOW) 10' (3.05 m) 30' (9.15 m) 10' (3.05 m)
- 2 4" (100) SOLID (YELLOW)
- 7 4" (100) SKIP-DASH (WHITE)

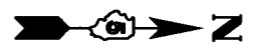

STA. 194+95.28 (US 136) =
STA. 500+00.00 (CEDAR AVE.)

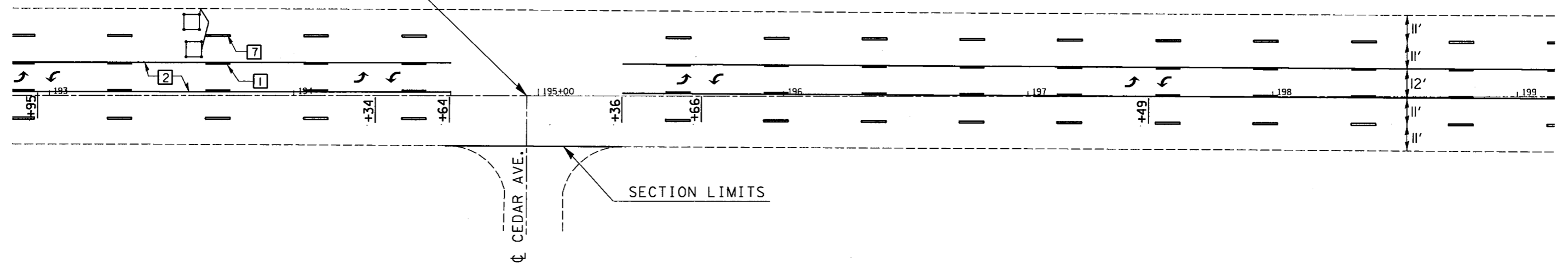

PLOT DATE = 3/28/2006
 FILE NAME = c:\pavement\48z198\pavement\pavement.dgn
 USER NAME = c:\pavement\48z198\pavement\c:\pavement\48z198\pavement.dgn

REVISIONS		ILLINOIS DEPARTMENT OF TRANSPORTATION
NAME	DATE	
		PAVEMENT MARKING & DETECTOR LOOP PLANS

SCALE: VERT. _____
 HORIZ. _____
 DATE _____

DRAWN BY _____
 CHECKED BY _____

F.A.P. RTE.	SECTION	COUNTY	TOTAL SHEETS	SHEET NO.
332	*	VERMILION	30	18
STA. 199+00		TO STA. 205+00		
FED. ROAD DIST. NO.		ILLINOIS FED. AID PROJECT		
*(RX,48Z-1)RS-1 & (47R-1)RS				

TYPICAL PAVEMENT MARKING LEGEND

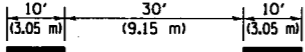
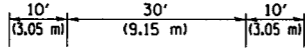
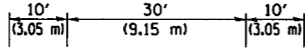
- 1 4" (100) SKIP-DASH (YELLOW) 
- 2 4" (100) SOLID (YELLOW) 
- 7 4" (100) SKIP-DASH (WHITE) 

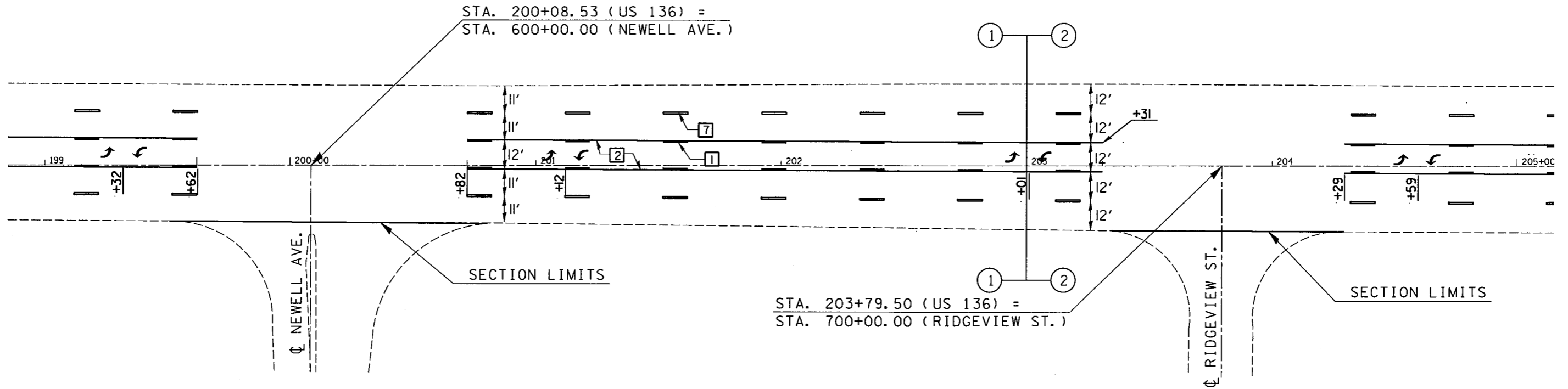

PLOT DATE * 3/25/2006
 FILE NAME * d:\projects\2004\199\18\18\striping_sheets.dgn
 USER NAME * ccrvllt

REVISIONS	
NAME	DATE

ILLINOIS DEPARTMENT OF TRANSPORTATION

PAVEMENT MARKING &
DETECTOR LOOP PLANS

SCALE: VERT. DRAWN BY
 HORIZ. CHECKED BY
 DATE

F.A.P. RTE.	SECTION	COUNTY	TOTAL SHEETS	SHEET NO.
332	*	VERMILION	30	19
STA. 205+00		TO STA. 211+00		
FED. ROAD DIST. NO.		ILLINOIS FED. AID PROJECT		
*(RX,48Z-1)RS-1 & (47R-1)RS				

TYPICAL PAVEMENT MARKING LEGEND

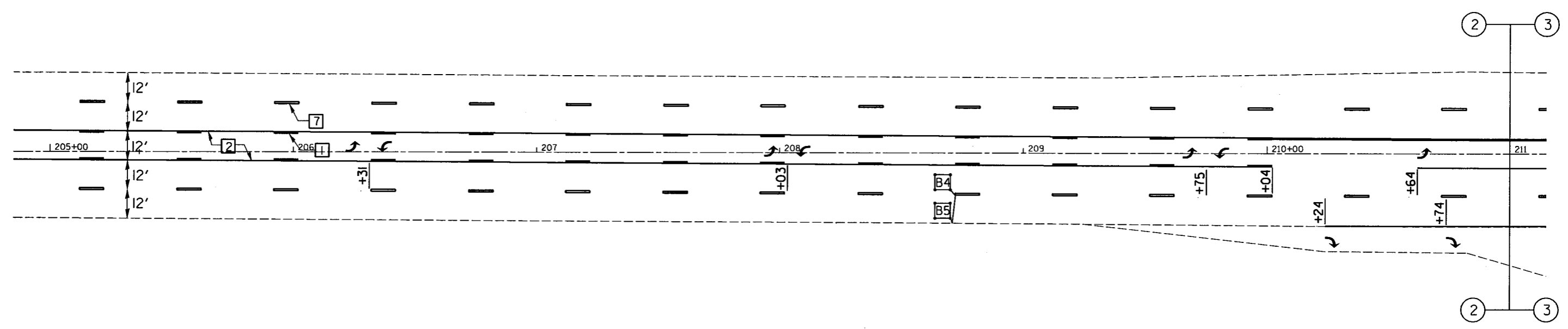
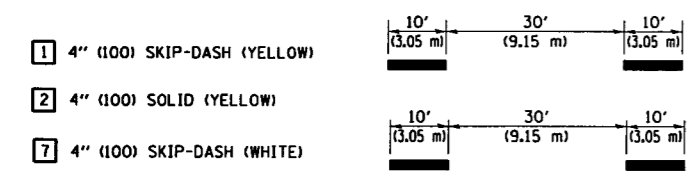

DETAIL OF DETECTOR LOOP WIRING
WIRED IN SERIES WITH SINGLE PAIR CABLE

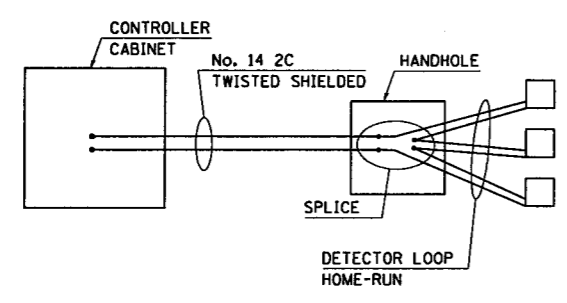

DETECTOR LOOP DATA
IL. RTE. 1 & K-MART PLAZA ENT / HARDEE'S ENT.

LOOP	SIZE	TURNS
A1-3	6' X 6'	3
A4-5	6' X 6'	4
B1-3	6' X 6'	3
B4-5	6' X 6'	4

NOTE: ALL ADVANCE LOOPS SHALL BE REPLACED PER EXISTING LOCATION UNLESS OTHERWISE NOTED.

The existing detector loop lead-in cable is:
No. 14 2/C, Twisted Shielded

REVISIONS	
NAME	DATE

ILLINOIS DEPARTMENT OF TRANSPORTATION
PAVEMENT MARKING & DETECTOR LOOP PLANS
SCALE: VERT. _____ HORIZ. _____
DATE _____ DRAWN BY _____ CHECKED BY _____

PLOT DATE = 2/28/2006
 FILE NAME = c:\pavement\70119\pavement\pavement.dgn
 PLOT SCALE = 1/8" = 1'-0"
 PLOT NAME = pavement

F.A.P. RTE.	SECTION	COUNTY	TOTAL SHEETS	SHEET NO.
332		VERMILION	30	20
STA. 211+00		TO STA. 217+00		
FED. ROAD DIST. NO.		ILLINOIS FED. AID PROJECT		
*IRX,48Z-1RS-1 & 147R-1RS				

TYPICAL PAVEMENT MARKING LEGEND

- 1 4" (100) SKIP-DASH (YELLOW)
- 2 4" (100) SOLID (YELLOW)
- 4 4" (100) DOUBLE YELLOW (NARROW)
- 7 4" (100) SKIP-DASH (WHITE)
- 8 4" (100) SOLID (WHITE)
- 10 6" (150) CROSS WALK (WHITE)
- 11 24" (600) STOP BAR (WHITE)



DETECTOR LOOP LAYOUT

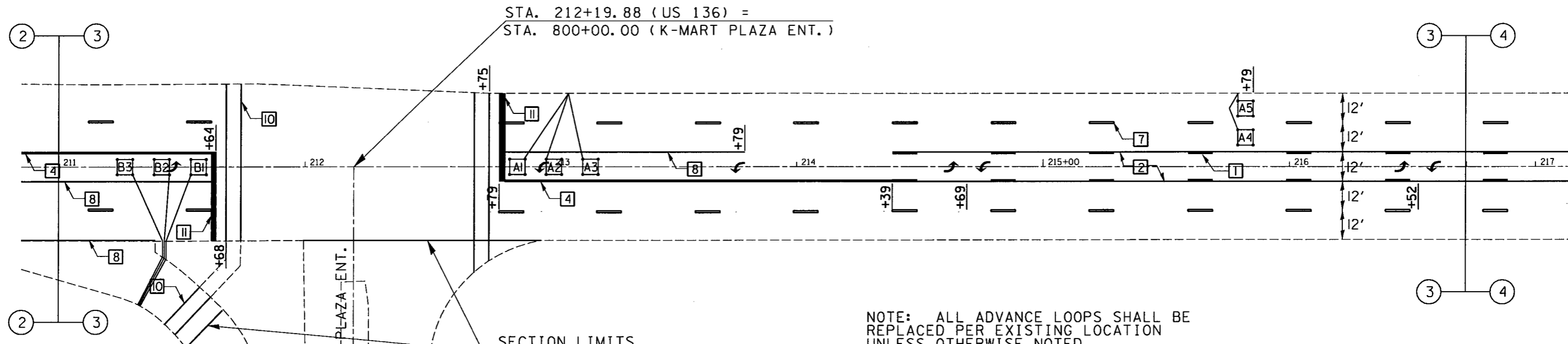
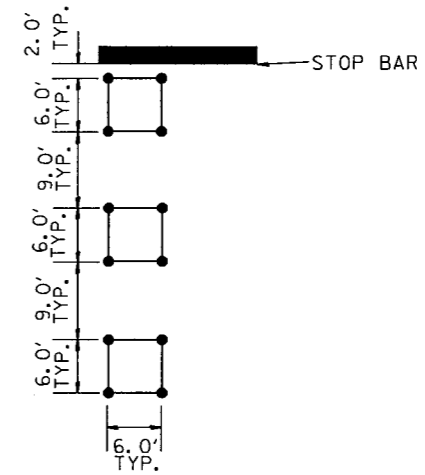

NOTE: ALL ADVANCE LOOPS SHALL BE REPLACED PER EXISTING LOCATION UNLESS OTHERWISE NOTED.

DETECTOR LOOP DATA

IL. RTE. 1 & K-MART PLAZA ENT / HARDEE'S ENT.

LOOP	SIZE	TURNS
A1-3	6' X 6'	3
A4-5	6' X 6'	4
B1-3	6' X 6'	3
B4-5	6' X 6'	4

DETAIL OF DETECTOR LOOP WIRING

WIRED IN SERIES WITH SINGLE PAIR CABLE

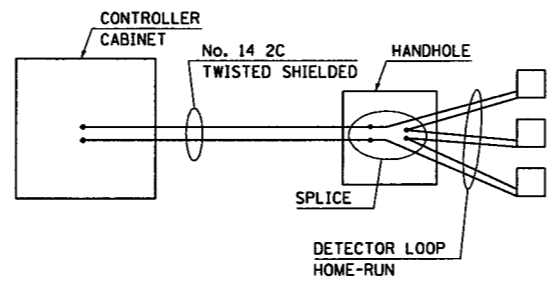

The existing detector loop lead-in cable is:

No. 14 2/C, Twisted Shielded

REVISIONS	
NAME	DATE

ILLINOIS DEPARTMENT OF TRANSPORTATION

PAVEMENT MARKING & DETECTOR LOOP PLANS

SCALE: VERT. HORIZ. DATE

DRAWN BY CHECKED BY

PLOT DATE: 3/28/2006
 FILE NAME: c:\projects\70119\pavement\striping\sheets.dgn
 USER: NAME: c:\users\j...
 USER: NAME: c:\users\j...

F.A.P. RTE.	SECTION	COUNTY	TOTAL SHEETS	SHEET NO.
332		VERMILION	30	21

STA. 217+00	TO STA. 223+00
FED. ROAD DIST. NO.	ILLINOIS FED. AID PROJECT
•(RX,46Z-1RS-1 & 147R-1RS)	

CURVE 50
 P.I. STA = 223+61.96
 $\Delta = 10^\circ 18' 02.05''$
 $D = 0^\circ 57' 22.80''$
 $R = 5,991.19$
 $T = 540.00$
 $L = 1,077.99$
 $E = 24.29$
 $e =$
 $T.R. =$
 $S.E. RUN =$
 $P.C. STA = 218+21.96$
 $P.T. STA = 228+99.05$

TYPICAL PAVEMENT MARKING LEGEND

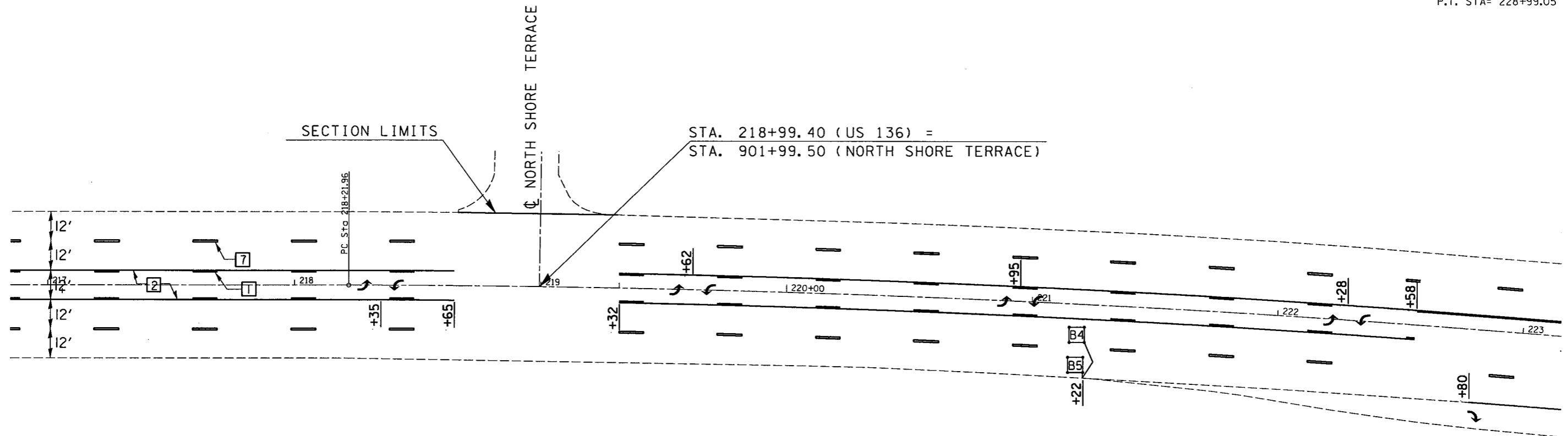
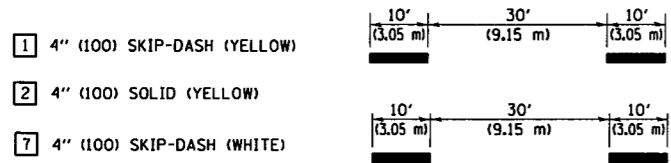

DETAIL OF DETECTOR LOOP WIRING
 WIRED IN SERIES WITH SINGLE PAIR CABLE

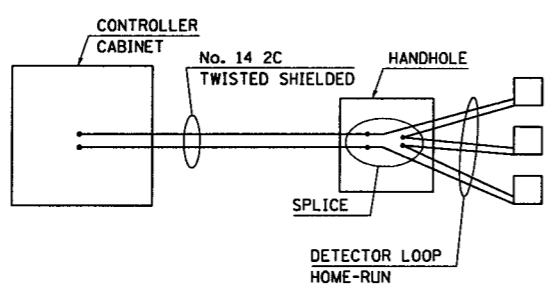

DETECTOR LOOP DATA

IL. RTE. 1 & LAKE SHORE DR / VILLAGE MALL ENT

LOOP	SIZE	TURNS
A1-3	6' X 6'	3
A4-5	6' X 6'	4
B1-3	6' X 6'	3
B4-5	6' X 6'	4

The existing detector loop lead-in cable is:

No. 14 2/C, Twisted Shielded

NOTE: ALL ADVANCE LOOPS SHALL BE REPLACED PER EXISTING LOCATION UNLESS OTHERWISE NOTED.

REVISIONS	
NAME	DATE

ILLINOIS DEPARTMENT OF TRANSPORTATION
 PAVEMENT MARKING &
 DETECTOR LOOP PLANS
 SCALE: VERT. DRAWN BY
 HORIZ. CHECKED BY
 DATE

PLOT DATE: 5/28/2006
 PLOT SCALE: 1/8" = 1'-0"
 USER NAME: carroll-t

F.A.P. RTE.	SECTION	COUNTY	TOTAL SHEETS	SHEET NO.
332		VERMILION	30	22
STA. 223+00		TO STA. 229+00		
ILLINOIS FED. AID PROJECT		*RX,48Z-1RS-1 & (47R-1RS		

TYPICAL PAVEMENT MARKING LEGEND

- 1 4" (100) SKIP-DASH (YELLOW)
- 2 4" (100) SOLID (YELLOW)
- 4 4" (100) DOUBLE YELLOW (NARROW)
- 7 4" (100) SKIP-DASH (WHITE)
- 8 4" (100) SOLID (WHITE)
- 10 6" (150) CROSS WALK (WHITE)
- 11 24" (600) STOP BAR (WHITE)

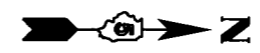

DETECTOR LOOP LAYOUT

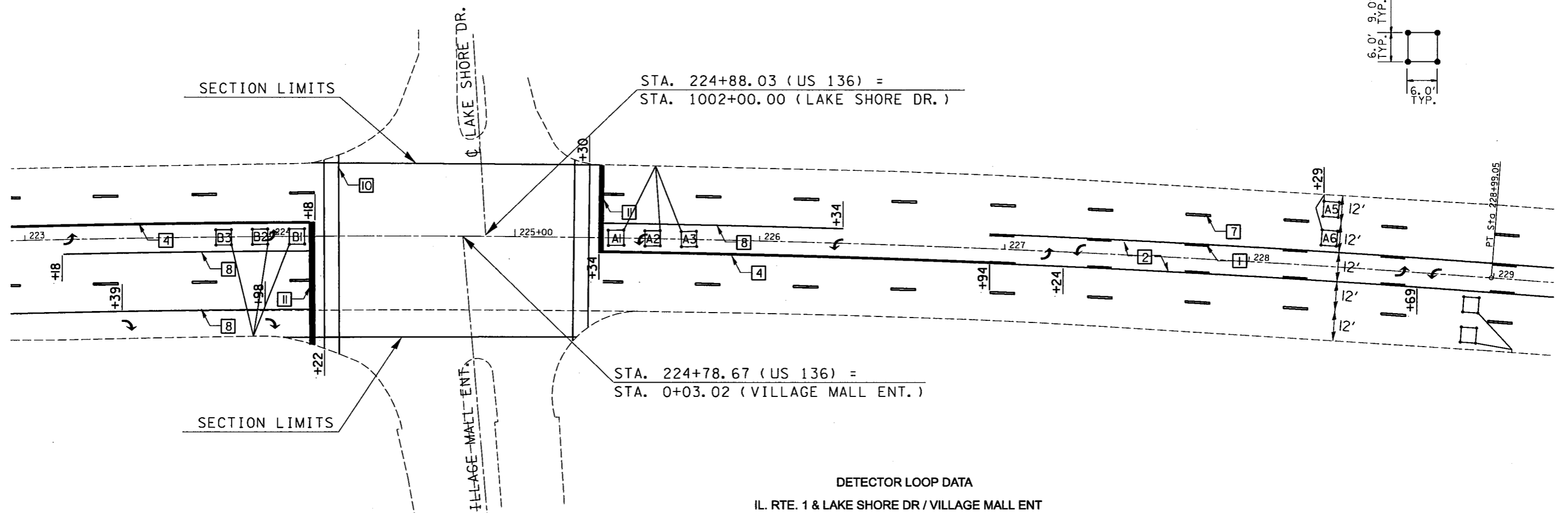
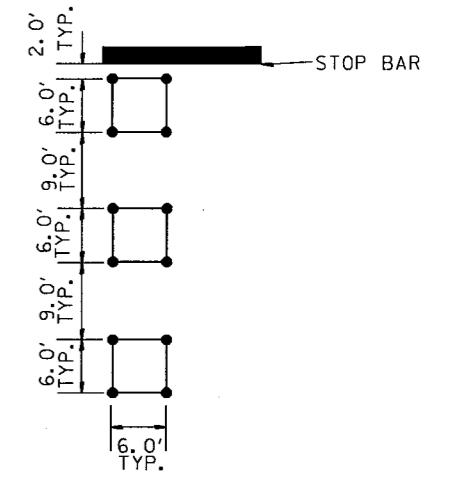

DETAIL OF DETECTOR LOOP WIRING

WIRED IN SERIES WITH SINGLE PAIR CABLE

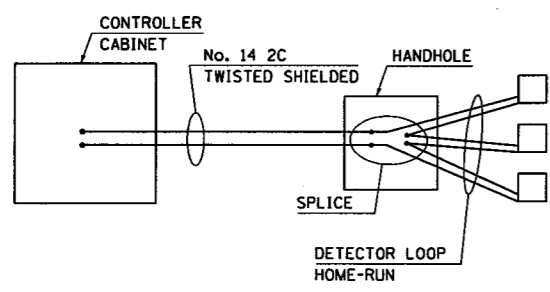

DETECTOR LOOP DATA

IL. RTE. 1 & LAKE SHORE DR / VILLAGE MALL ENT

LOOP	SIZE	TURNS
A1-3	6' X 6'	3
A4-5	6' X 6'	4
B1-3	6' X 6'	3
B4-5	6' X 6'	4

NOTE: ALL ADVANCE LOOPS SHALL BE REPLACED PER EXISTING LOCATION UNLESS OTHERWISE NOTED.

The existing detector loop lead-in cable is:
No. 14 2/C, Twisted Shielded

REVISIONS		ILLINOIS DEPARTMENT OF TRANSPORTATION
NAME	DATE	
		PAVEMENT MARKING & DETECTOR LOOP PLANS
SCALE:	VERT. HORIZ.	DRAWN BY CHECKED BY
DATE		

PLOT DATE = 3/25/2005
 PLOT SCALE = 1/8" = 1'-0"
 USER NAME = gbrroll1

F.A.P. RTE.	SECTION	COUNTY	TOTAL SHEETS	SHEET NO.
332	*	VERMILION	30	23
STA. 229+00		TO STA. 235+00		
FED. ROAD DIST. NO.		ILLINOIS FED. AID PROJECT		
*IRX,48Z-1RS-1 & 147R-1RS				

TYPICAL PAVEMENT MARKING LEGEND

- 1 4" (100) SKIP-DASH (YELLOW)
- 2 4" (100) SOLID (YELLOW)
- 4 4" (100) DOUBLE YELLOW (NARROW)
- 7 4" (100) SKIP-DASH (WHITE)
- 8 4" (100) SOLID (WHITE)
- 10 6" (150) CROSS WALK (WHITE)
- 11 24" (600) STOP BAR (WHITE)



DETECTOR LOOP LAYOUT

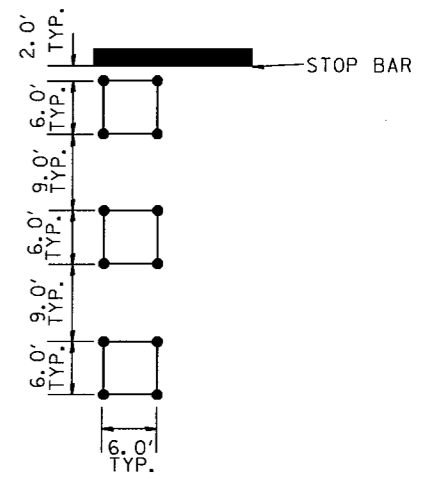

STA. 232+61.97 (US 136) =
STA. 1102+00.00 (LIBERTY LANE)

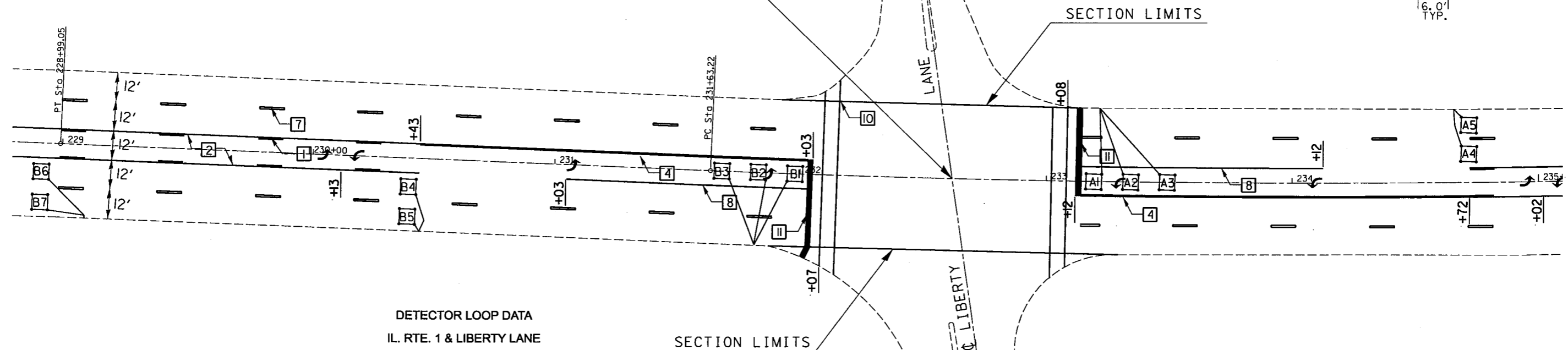

DETECTOR LOOP DATA
IL. RTE. 1 & LIBERTY LANE

LOOP	SIZE	TURNS
A1-3	6' X 6'	4
A4-5	6' X 6'	5
A6-7	6' X 6'	6
B1-3	6' X 6'	4
B4-5	6' X 6'	4
B6-7	6' X 6'	5

DETAIL OF DETECTOR LOOP WIRING

WIRED IN SERIES WITH MULTI-PAIR CABLE

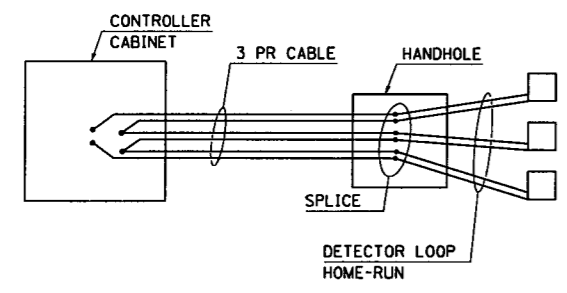

The existing detector loop lead-in cable is:
No. 18, 3pr., Lead-In

NOTE: ALL ADVANCE LOOPS SHALL BE REPLACED PER EXISTING LOCATION UNLESS OTHERWISE NOTED.

REVISIONS		ILLINOIS DEPARTMENT OF TRANSPORTATION
NAME	DATE	
		PAVEMENT MARKING & DETECTOR LOOP PLANS
SCALE:	VERT. HORIZ.	DRAWN BY
DATE		CHECKED BY

PLOT DATE = 3/25/2008
FILE NAME = c:\projects\70119\70119pavement\70119pavement.dwg
USER NAME = carrolljt

F.A.P. RTE.	SECTION	COUNTY	TOTAL SHEETS	SHEET NO.
332	*	VERMILION	30	24
STA. 235+00		TO STA. 241+00		
FED. ROAD DIST. NO.		ILLINOIS FED. AID PROJECT		
*(RX,482-1)RS-1 & (47R-1)RS				

CURVE 25
 P.I. STA= 235+63.22
 Δ = 7° 37' 47.38"
 D= 0° 57' 18.50"
 R= 5,998.68
 T= 400.00
 L= 798.82
 E= 13.32
 θ =
 T.R.=
 S.E. RUN=
 P.C. STA= 231+63.22
 P.T. STA= 239+62.04

TYPICAL PAVEMENT MARKING LEGEND

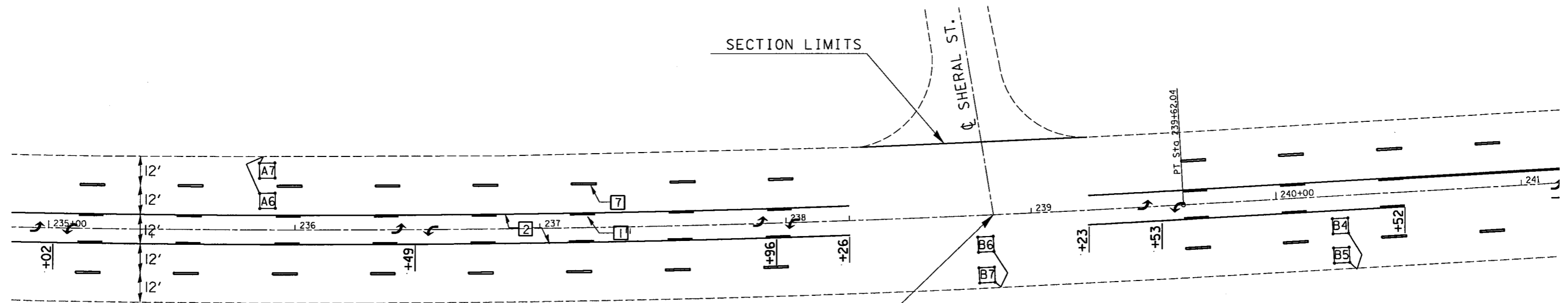
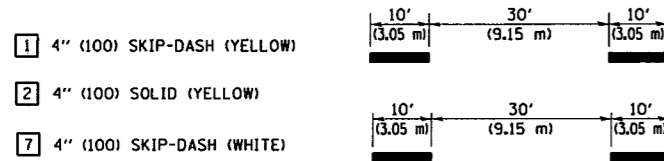

NOTE: ALL ADVANCE LOOPS SHALL BE REPLACED PER EXISTING LOCATION UNLESS OTHERWISE NOTED.

STA. 238+84.66 (US 136) =
 STA. 1202+00.00 (SHERAL ST.)

DETECTOR LOOP DATA
 IL. RTE. 1 & LIBERTY LANE

LOOP	SIZE	TURNS
A1-3	6' X 6'	4
A4-5	6' X 6'	5
A6-7	6' X 6'	6
B1-3	6' X 6'	4
B4-5	6' X 6'	4
B6-7	6' X 6'	5

The existing detector loop lead-in cable is:

No. 18, 3pr., Lead-In

DETECTOR LOOP DATA
 IL. RTE. 1 & SHADY LANE

LOOP	SIZE	TURNS
A1-3	6' X 6'	3
A4-5	6' X 6'	4
A6-7	6' X 6'	5
B1-3	6' X 6'	3
B4-5	6' X 6'	3
B6-7	6' X 6'	4

The existing detector loop lead-in cable is:

No. 14 2/C, Twisted Shielded

DETAIL OF DETECTOR LOOP WIRING

WIRED IN SERIES WITH MULTI-PAIR CABLE

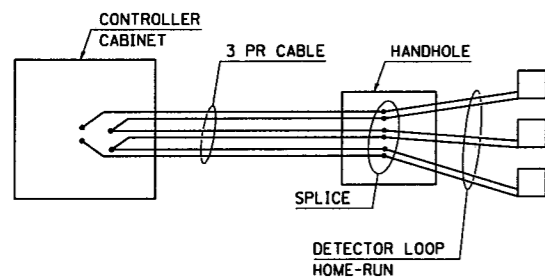

DETAIL OF DETECTOR LOOP WIRING

WIRED IN SERIES WITH SINGLE PAIR CABLE

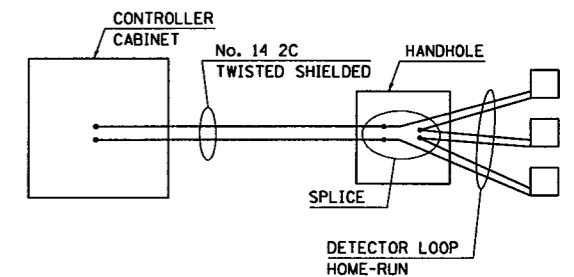

REVISIONS	
NAME	DATE

ILLINOIS DEPARTMENT OF TRANSPORTATION

PAVEMENT MARKING &
 DETECTOR LOOP PLANS

SCALE: VERT.
 HORIZ.
 DATE

DRAWN BY
 CHECKED BY

F.A.P. RTE.	SECTION	COUNTY	TOTAL SHEETS	SHEET NO.
332	*	VERMILION	30	25
STA. 241+00		TO STA. 247+00		
FED. ROAD DIST. NO.		ILLINOIS FED. AID PROJECT		
*(RX, 482-11RS-1 & 47R-11RS)				

TYPICAL PAVEMENT MARKING LEGEND

- 1 4" (100) SKIP-DASH (YELLOW)
- 2 4" (100) SOLID (YELLOW)
- 4 4" (100) DOUBLE YELLOW (NARROW)
- 7 4" (100) SKIP-DASH (WHITE)
- 8 4" (100) SOLID (WHITE)
- 10 6" (150) CROSS WALK (WHITE)
- 11 24" (600) STOP BAR (WHITE)



STA. 242+81.87 (US 136) =
STA. 0+03.02 (SHADY LANE RD.)

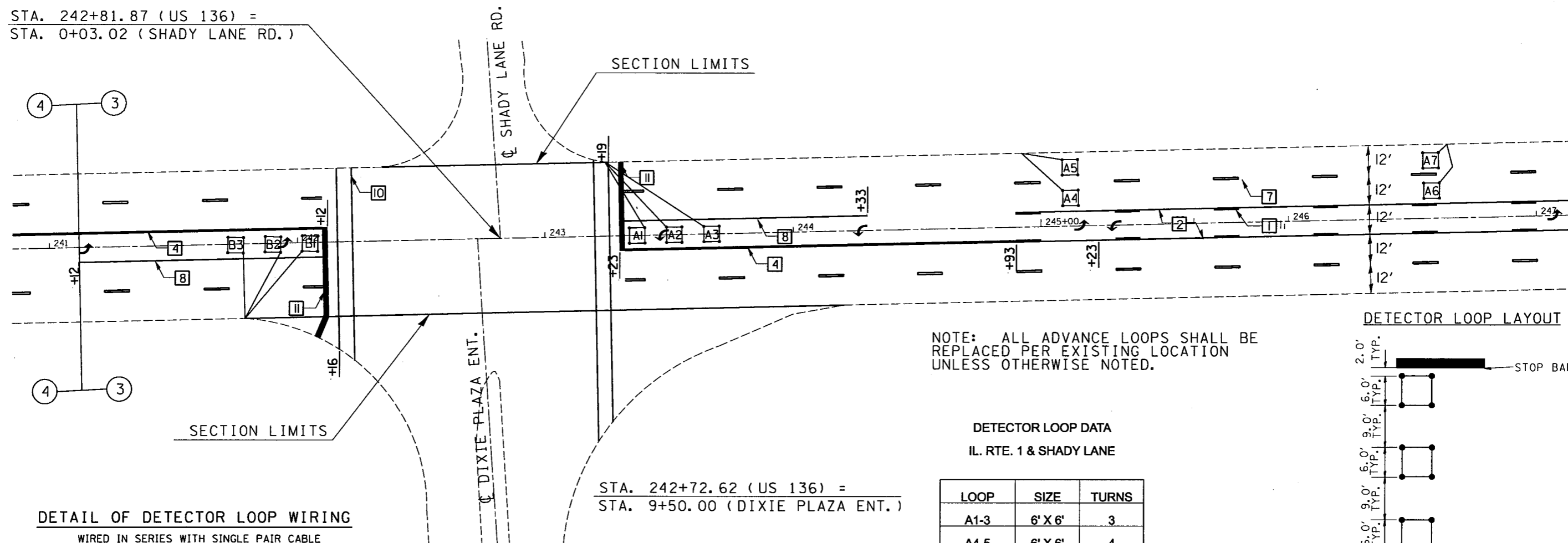

NOTE: ALL ADVANCE LOOPS SHALL BE REPLACED PER EXISTING LOCATION UNLESS OTHERWISE NOTED.

DETECTOR LOOP LAYOUT



**DETECTOR LOOP DATA
IL. RTE. 1 & SHADY LANE**

LOOP	SIZE	TURNS
A1-3	6' X 6'	3
A4-5	6' X 6'	4
A6-7	6' X 6'	5
B1-3	6' X 6'	3
B4-5	6' X 6'	3
B6-7	6' X 6'	4

STA. 242+72.62 (US 136) =
STA. 9+50.00 (DIXIE PLAZA ENT.)

**DETAIL OF DETECTOR LOOP WIRING
WIRED IN SERIES WITH SINGLE PAIR CABLE**

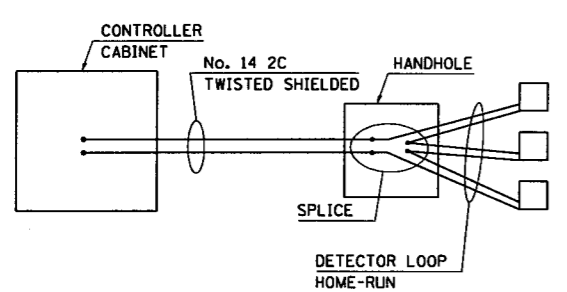

REVISIONS		ILLINOIS DEPARTMENT OF TRANSPORTATION
NAME	DATE	
		PAVEMENT MARKING & DETECTOR LOOP PLANS

The existing detector loop lead-in cable is:

No. 14 2/C, Twisted Shielded

SCALE: VERT. _____
HORIZ. _____
DATE _____ DRAWN BY _____
CHECKED BY _____

PLOT DATE * 3/28/2006
 FILE NAME * c:\pavement\2006\1198\1198pavement.dgn
 USER NAME * dcrabtree

F.A.P. RTE.	SECTION	COUNTY	TOTAL SHEETS	SHEET NO.
332	*	VERMILION	30	26
STA. 247+00		TO STA. 251+25		
FED. ROAD DIST. NO.		ILLINOIS FED. AID PROJECT		

*(RX,48Z-1RS-1 & (47R-1RS

TYPICAL PAVEMENT MARKING LEGEND

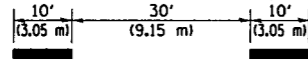
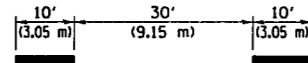
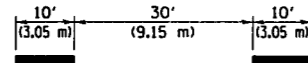
- 1 4" (100) SKIP-DASH (YELLOW) 
- 2 4" (100) SOLID (YELLOW) 
- 7 4" (100) SKIP-DASH (WHITE) 



CURVE 29
 P.I. STA= 252+93.12
 $\Delta = 0^\circ 19' 59.80''$
 $D = 0^\circ 01' 59.98''$
 $R = 171,916.04$
 $T = 500.00$
 $L = 1,000.00$
 $E = 0.73$
 $e =$
 $T.R. =$
 S.E. RUN=
 P.C. STA= 247+93.12
 P.T. STA= 257+93.12

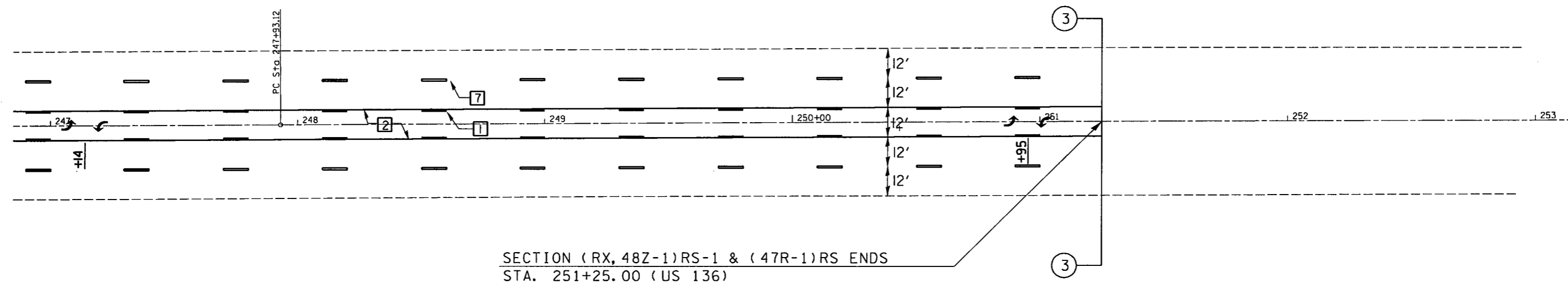

PLOT DATE = 3/28/2006
 FILE NAME = c:\pavement\70119\pavement\pavement.dwg
 PLOT SCALE = 43200 / IN.
 USER NAME = gbarclay

REVISIONS	
NAME	DATE

ILLINOIS DEPARTMENT OF TRANSPORTATION

PAVEMENT MARKING &
 DETECTOR LOOP PLANS

SCALE: VERT. _____
 HORIZ. _____

DATE _____ DRAWN BY _____
 CHECKED BY _____

F.A.P. RTE.	SECTION	COUNTY	TOTAL SHEETS	SHEET NO.
332		VERMILION	30	27

• (RX,48Z-1)RS-1 & (47R-1)RS

TYPICAL APPLICATIONS OF PAVEMENT MARKINGS AND MARKERS

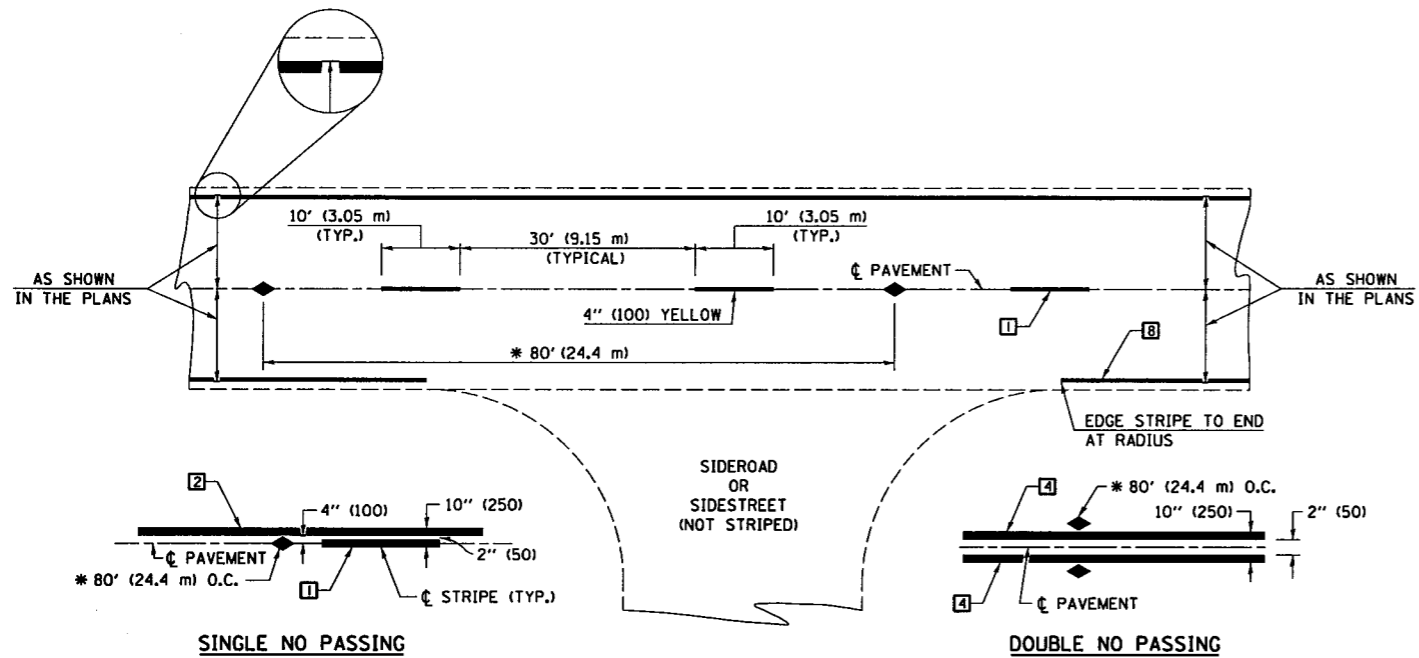

* REDUCE TO 40' (12.2 m) O.C. ON CURVES WITH POSTED OR ADVISORY SPEEDS OF 45 mph (70 km/h) OR LESS.

TYPICAL PAVEMENT MARKING LEGEND

- 1 4" (100) SKIP-DASH (YELLOW)
- 2 4" (100) SOLID (YELLOW)
- 3 12" (300) DIAGONAL (YELLOW)
- 4 4" (100) DOUBLE YELLOW (NARROW)
- 5 RESERVED
- 6 RESERVED
- 7 4" (100) SKIP-DASH (WHITE)
- 8 4" (100) SOLID (WHITE)
- 9 12" (300) DIAGONAL (WHITE)
- 10 6" (150) CROSS WALK (WHITE)
- 11 24" (600) STOP BAR (WHITE)
- 12 8" (200) SOLID (WHITE)
- 13 4" (100) LANE LINE EXTENSIONS (WHITE)
- 14 4" (100) PARKING WHITE

TYPICAL PAVEMENT MARKERS LEGEND

- ◆ TWO-WAY AMBER MARKER
- ▶ ONE-WAY AMBER MARKER
- ▷ ONE-WAY CRYSTAL MARKER

DETAIL OF RURAL LEFT TURN LANE

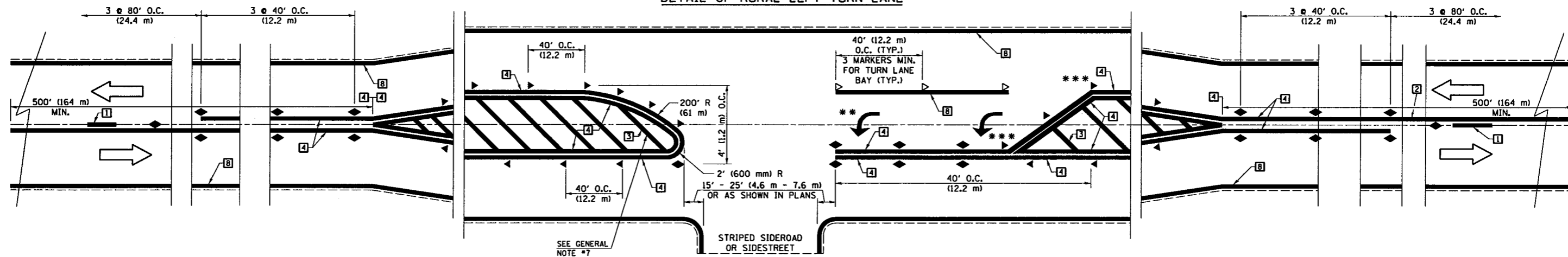

*** REDUCE SPACING IF NECESSARY TO ASSURE MARKERS AT CORNER POINTS.
 ** TURN ARROWS SHALL BE PLACED AS SHOWN ON SHEET #2.

SHEET 1 OF 4

DESIGNED	NAME	DATE	REVISIONS	NAME	DATE
J.M.H.	J.M.H.	5/85			
FMS	FMS	6/85		GEOMETRICS/K.A.G.	07/02
CDD NO.	F-5.25	5/88		K.A.G.	09/05

ALL DIMENSIONS ARE IN INCHES (MILLIMETERS) UNLESS OTHERWISE SHOWN.

F.A.P. RTE.	SECTION	COUNTY	TOTAL SHEETS	SHEET NO.
332		VERMILION	30	28

• (RX,48Z-1)RS-1 & (47R-1)RS

TYPICAL APPLICATIONS OF PAVEMENT MARKINGS AND MARKERS

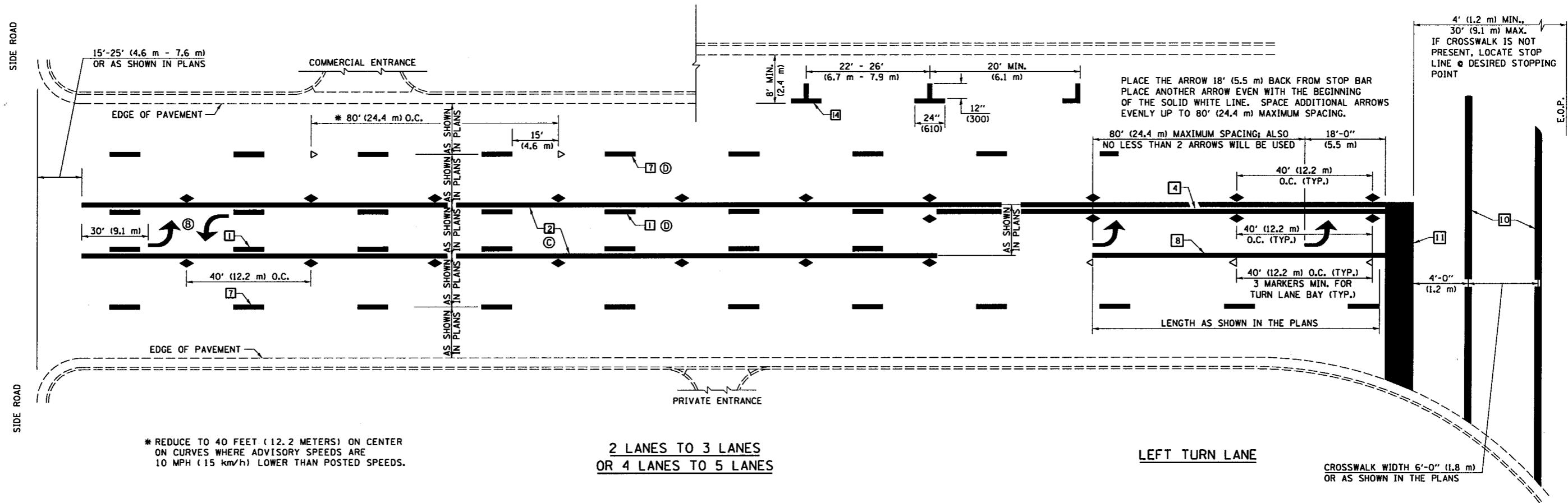

SHEET 2 OF 4

	NAME	DATE	REVISIONS
DESIGNED	J.M.H.	5/85	
CHECKED	FMS	6/85	
CADD NO.	F-5.25		

NAME	DATE
GEOMETRICS/K.A.G.	07/02
K.A.G.	09/05

ALL DIMENSIONS ARE IN INCHES (MILLIMETERS) UNLESS OTHERWISE SHOWN.

F.A.P. RTE.	SECTION	COUNTY	TOTAL SHEETS	SHEET NO.
332	*	VERMILION	30	29

(RX,48Z-1)RS-1 & (47R-1)RS

TYPICAL APPLICATIONS OF PAVEMENT MARKINGS AND MARKERS

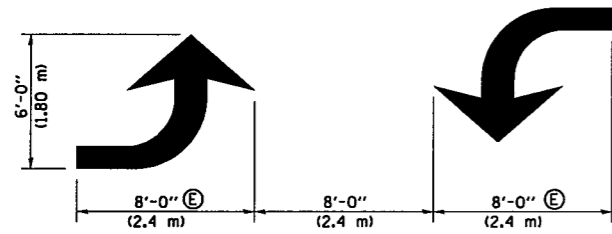

TYPICAL DOUBLE TURN ARROWS (WHITE)

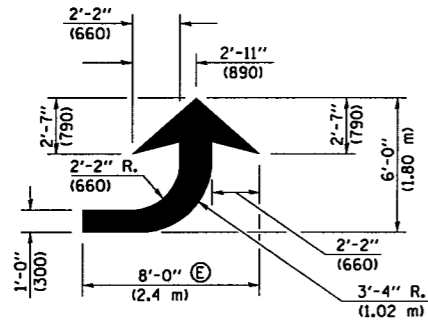

LEFT ARROW
REVERSE FOR RIGHT ARROW
AREA = 15.6 SQ. FT. (1.47 m²)
(WHITE)

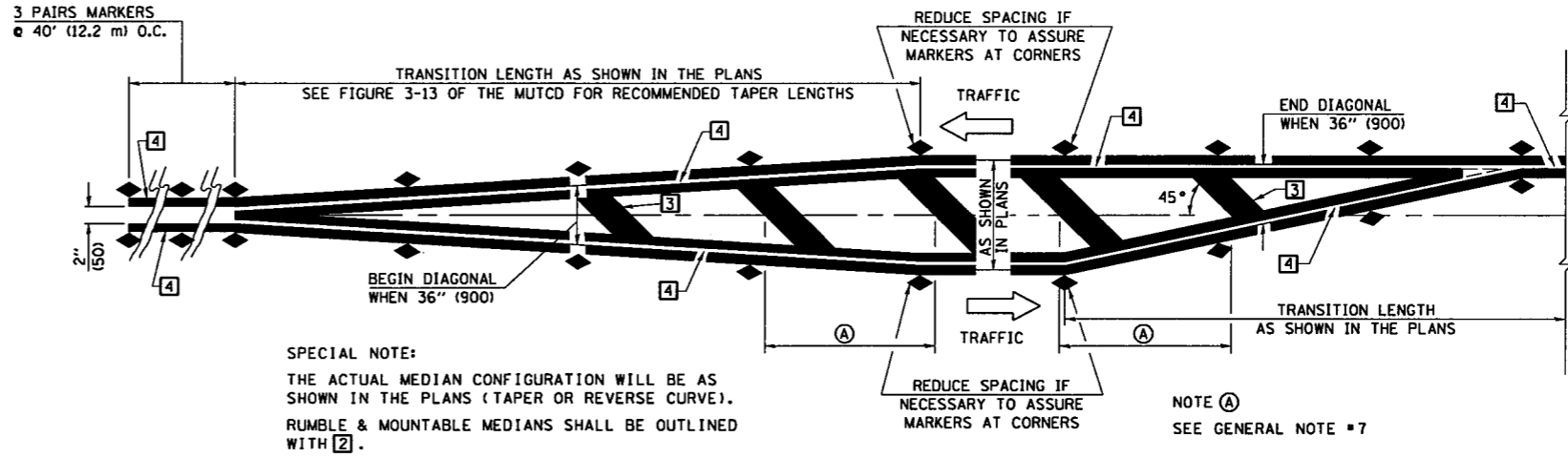

SPECIAL NOTE:
THE ACTUAL MEDIAN CONFIGURATION WILL BE AS SHOWN IN THE PLANS (TAPER OR REVERSE CURVE).
RUMBLE & MOUNTABLE MEDIANS SHALL BE OUTLINED WITH [2].

NOTE (A)
SEE GENERAL NOTE # 7

TYPICAL MEDIAN TRANSITIONS

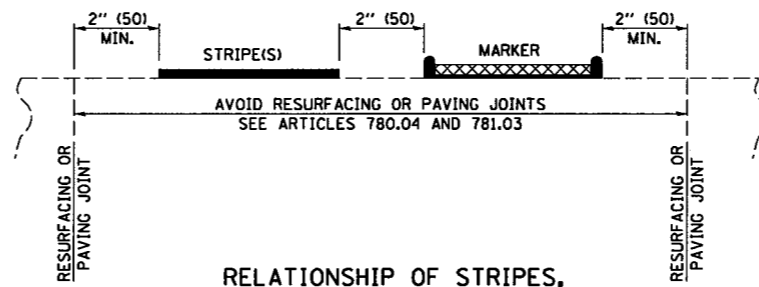

RELATIONSHIP OF STRIPES, MARKERS AND JOINTS

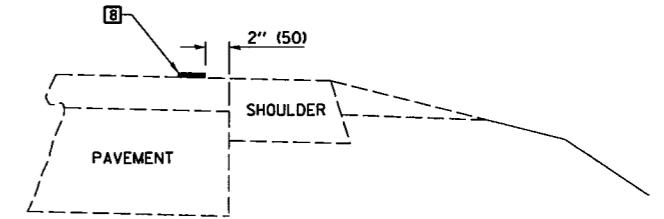

RELATIONSHIP OF EDGE STRIPE TO SAFETY SHOULDER OR PAVED SURFACE

SPECIAL NOTES:

- (B) TURN ARROW PAIRS SHALL BE PLACED AT 250' (75 m) INTERVALS AND SHALL BE EVENLY SPACED BETWEEN BOTH ENDS OF THE BIDIRECTIONAL LEFT TURN LANE.
- (C) THE SOLID YELLOW PAVEMENT MARKINGS [2] SHOULD GENERALLY START OR END NEAR THE RADIUS POINT OF EACH STREET RETURN EXCEPT WHERE ONE OR BOTH ENDS WOULD INCLUDE STOP BARS.
- (D) THE SKIP-DASH PAVEMENT MARKINGS [1] OR [7] SHOULD BE CENTERED BETWEEN BOTH ENDS OF EACH CITY BLOCK AND SHALL BE PLACED SO THEY LINE UP ACROSS FROM EACH OTHER. SEE EXAMPLE ON SHEET 2 OF 3.
- (E) TURN ARROW SIZE DEPENDS ON THE LOCATION.
RURAL LOCATION - LARGE ARROW SIZE
URBAN LOCATION - SMALL ARROW SIZE

GENERAL NOTES

- 1. WHEN MEDIANS ARE PRESENT, PAVEMENT MARKINGS ARE TO BE PLACED ADJACENT TO MEDIANS.
- 2. SCALE: NONE
- 3. SOME OF THE INFORMATION INCLUDED WITH THIS DETAIL MAY NOT BE APPLICABLE TO THIS IMPROVEMENT.
- 4. PAVEMENT MARKINGS ARE TO BE EXTENDED THROUGH OMISSIONS WHEN APPLICABLE.
- 5. A STRIPING KEY IS AVAILABLE ELSEWHERE AND SHALL BE SHOWN WHERE THE QUANTITIES ARE LISTED.
- 6. FINAL PAVEMENT MARKINGS SHALL BE IN PLACE PRIOR TO PLACING ANY RAISED REFLECTIVE PAVEMENT MARKERS.
- 7. THE FOLLOWING CRITERIA SHALL BE USED FOR SELECTING THE DIAGONAL PAVEMENT MARKING SPACING.
<30 MPH USE 15' (<50 km/h USE 4.5 m)
30-45 MPH USE 20' (50-75 km/h USE 6.0 m)
>45 MPH USE 30' (>75 km/h USE 9.0 m)

SHEET 3 OF 4

NAME	DATE	REVISIONS
J.M.H.	5/85	
FMS	6/85	
C.T.D.	6/88	
F-5.25		

ALL DIMENSIONS ARE IN INCHES (MILLIMETERS) UNLESS OTHERWISE SHOWN.

F.A.P. RTE.	SECTION	COUNTY	TOTAL SHEETS	SHEET NO.
332	*	VERMILION	30	30

• (RX,48Z-1)RS-1 & (47R-1)RS

TYPICAL APPLICATIONS OF PAVEMENT MARKINGS AND MARKERS

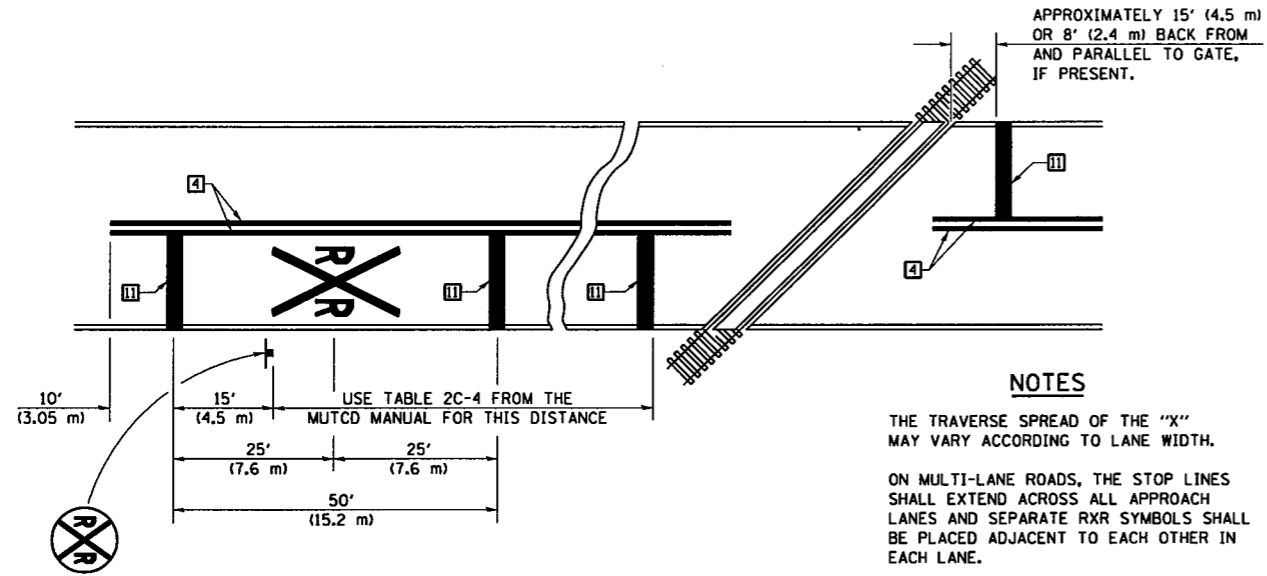

NOTES

THE TRAVERSE SPREAD OF THE "X" MAY VARY ACCORDING TO LANE WIDTH.

ON MULTI-LANE ROADS, THE STOP LINES SHALL EXTEND ACROSS ALL APPROACH LANES AND SEPARATE RXR SYMBOLS SHALL BE PLACED ADJACENT TO EACH OTHER IN EACH LANE.

WHEN THE PAVEMENT MARKING SYMBOL IS USED, A PORTION OF THE SYMBOL SHOULD BE LOCATED DIRECTLY ADJACENT TO THE ADVANCE WARNING SIGN (W10-1) AS PLACED BY TABLE II-1, CONDITION B OF THE MUTCD.

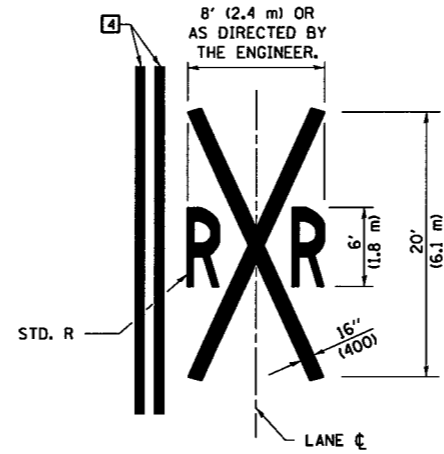

PAVEMENT MARKINGS AT RAILROAD-HIGHWAY GRADE CROSSING

SHEET 4 OF 4

	NAME	DATE	REVISIONS
DESIGNED	J.M.H.	5/85	NAME
CHECKED	FMS	6/85	GEOMETRICS/K.A.G.
CADD NO.	F-5.25		K.A.G.

ALL DIMENSIONS ARE IN INCHES (MILLIMETERS) UNLESS OTHERWISE SHOWN.