

F.A.P. RTE.	SECTION	COUNTY	TOTAL SHEETS	SHEET NO.
774	107 WRS-2, L	EFFINGHAM	127	72
FED. ROAD DIST. NO.	ILLINOIS	FED. AID PROJECT		

CONTRACT NO. 74130

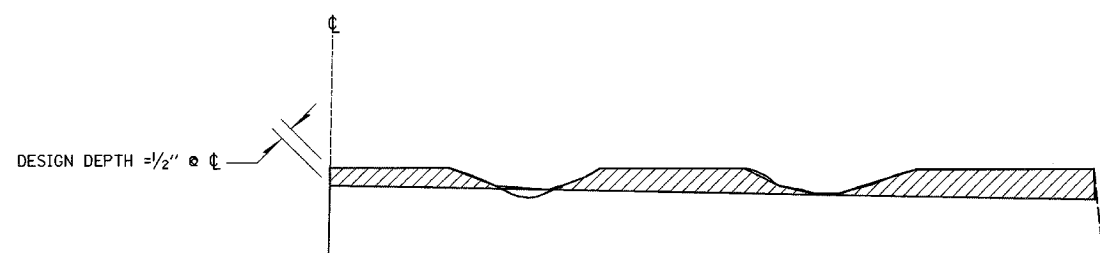

NOTES:

1. MILLING SHALL BE DONE TO ATTAIN REQUIRED SLOPE IN CROWN SECTIONS
2. EXISTING S.E. AND S.E. TRANSITIONS SHALL BE MAINTAINED UNLESS OTHERWISE SHOWN ON THE PLANS.
3. MILLING TO THE BOTTOM OF WHEEL RUTS SHALL NOT BE NECESSARY UNLESS REQUIRED TO OBTAIN SLOPE OR THE DESIGN DEPTH AT CENTERLINE.
4. THE AVERAGE DEPTH OF MILLING IS ESTIMATED TO BE 1/2" BUT MAY VARY IN ISOLATED LOCATIONS.

BITUMINOUS SURFACE REMOVAL (VARIABLE DEPTH) DETAIL

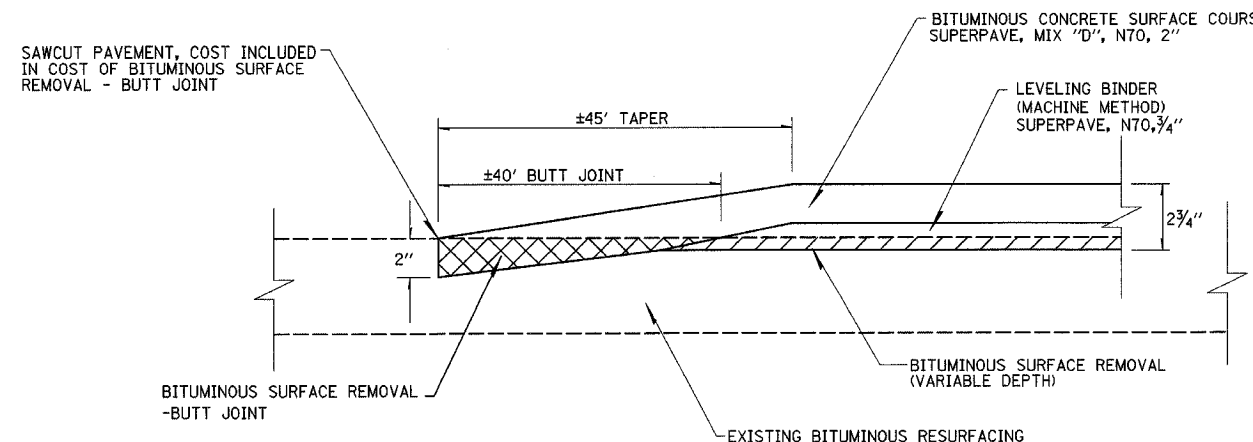

- BITUMINOUS SURFACE REMOVAL - BUTT JOINT
- BITUMINOUS SURFACE REMOVAL (VARIABLE DEPTH)

BITUMINOUS SURFACE REMOVAL-BUTT JOINT DETAIL

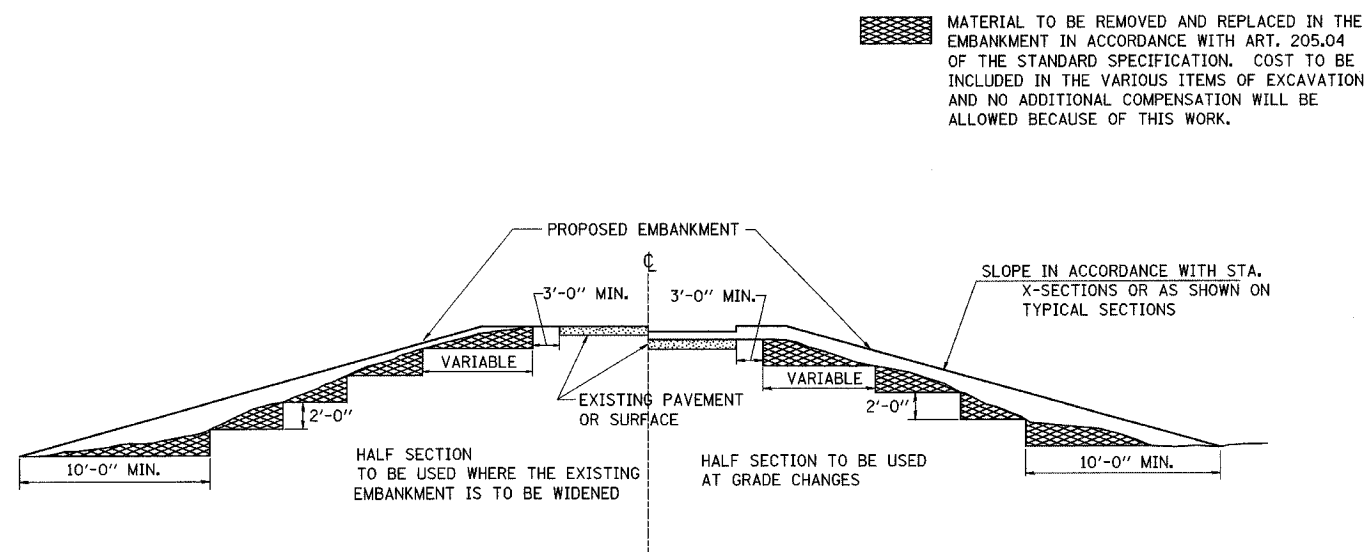

TYPICAL CROSS SECTION SHOWING STEP CONSTRUCTION ON EXISTING FILL

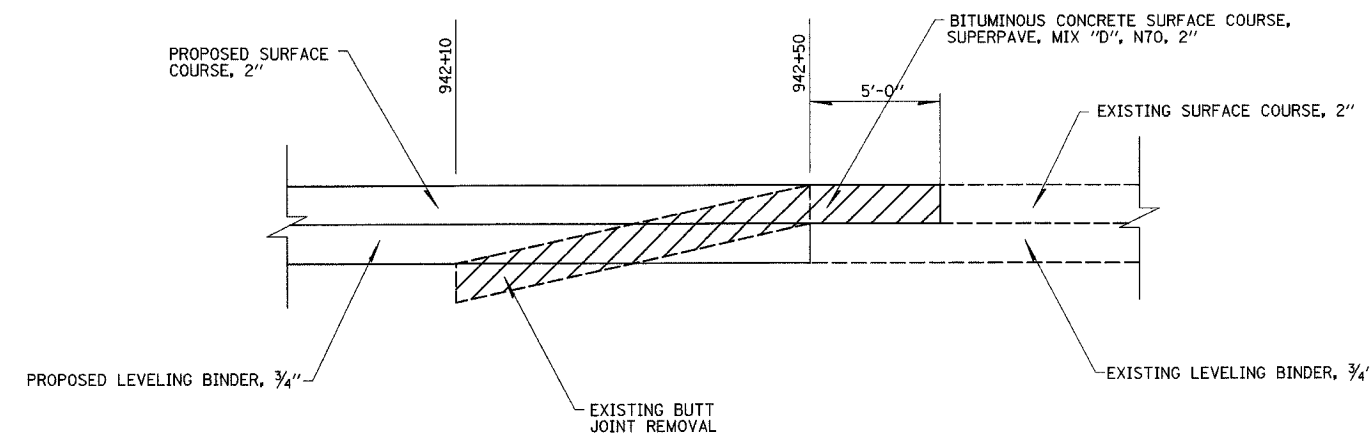

BUTT JOINT REMOVAL DETAIL

NOTE: THIS WORK WILL BE PAID FOR AT THE CONTRACT UNIT PRICE FOR BITUMINOUS SURFACE REMOVAL - BUTT JOINT.

REVISIONS		ILLINOIS DEPARTMENT OF TRANSPORTATION
NAME	DATE	
		MISCELLANEOUS ROADWAY DETAILS

DATE 8/02

DRAWN BY DIST. 7
CHECKED BY BWC