

RAMP TYPICAL SECTION
NOT TO SCALE

LEGEND FOR RAMP TYPICAL SECTION

- ① PROPOSED BITUMINOUS SURFACE CSE. (1.5" DEPTH)
- ② PROPOSED BITUMINOUS LEVELING CSE. (VARIABLE DEPTH)
- ③ PROPOSED POROUS FRICTION CSE. (0.1' DEPTH)
- ④ EXISTING BITUMINOUS SURFACE CSE. (2" DEPTH)
- ⑤ EXISTING BITUMINOUS BASE CSE. (2" MAX. DEPTH)
- ⑥ EXISTING BITUMINOUS SURFACE CSE. (2" DEPTH)
- ⑦ EXISTING CRUSHED AGG. BASE CSE. (7" DEPTH)
- ⑧ PROPOSED TOPSOILING (FROM OFF SITE)
- ⑨ EXISTING RAMP PAVEMENT - MATCH GRADE

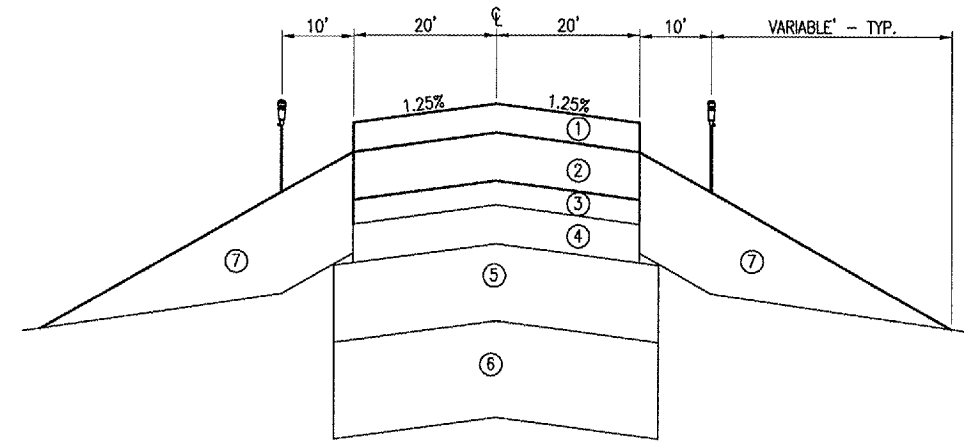

TAXIWAY B & C TYPICAL SECTION
NOT TO SCALE

LEGEND FOR TYPICAL SECTION "B-B"

- ① PROPOSED BITUMINOUS SURFACE CSE. (1.5" DEPTH)
- ② PROPOSED BITUMINOUS LEVELING CSE. (VARIABLE DEPTH)
- ③ PROPOSED POROUS FRICTION CSE. (0.1' DEPTH)
- ④ EXISTING BITUMINOUS SURFACE CSE. (2" DEPTH)
- ⑤ EXISTING BITUMINOUS BASE CSE. (6" DEPTH)
- ⑥ EXISTING COMPACTED EARTH SUBGRADE (12" MIN.)
- ⑦ PROPOSED TOPSOILING (FROM OFF SITE)

DATE	REVISION	BY

KEWANEE MUNICIPAL AIRPORT
KEWANEE, HENRY COUNTY, ILLINOIS

IL PROJ.: E21-3533 A.I.P. PROJ.: 3-17-0058-B10

FILE Project No. 810-06TXD_0800	LAYOUT	R.A.W.	12/28/05
Drawn R-521CON.DWG	DRAWN	R.A.W.	12/28/05
Scale NOT TO SCALE	REVIEWED	C.A.H.	04/27/09
Date 12/28/05			

Hanson Professional Services Inc.
3125 Dandy Trail, Suite 100
Indianapolis, Indiana 46214
Offices Nationwide

OVERLAY TAXIWAYS AND APRON
PROPOSED TYPICAL SECTIONS

F:\AIRPORT\STATIONING\810-06\TXD\AIRPORT\SHHEE\IS-SPLIT\R-521CON.DWG - TYPICALS