

F.A.I.D. RTE.	SECTION	COUNTY	TOTAL SHEETS	SHEET NO.
1487	66R	DUPAGE	412	191
STA. 23+00.00		TO STA. 144+00.00		
FED. ROAD DIST. NO.		ILLINOIS	FED. AID PROJECT	
CONTRACT NO. 62376				

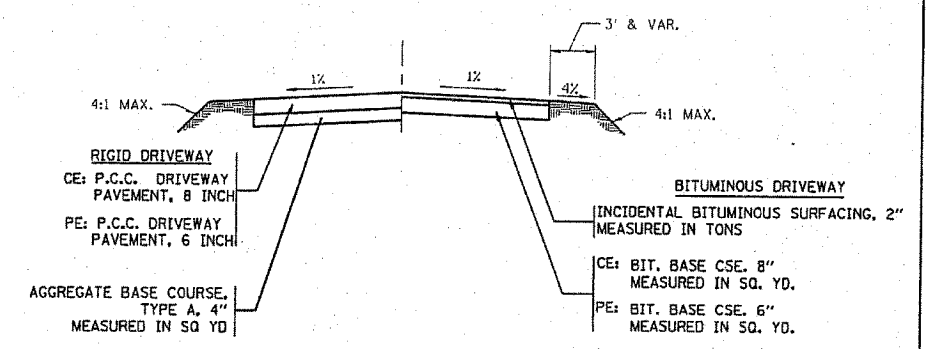

NOTES:

1. DRIVEWAY SLOPES, LOCATIONS, & GEOMETRIC LAYOUT SHALL BE IN ACCORDANCE WITH THE LATEST EDITION OF THE "HANDBOOK FOR POLICY ON PERMITS FOR ACCESS DRIVEWAYS TO STATE HIGHWAYS". FOR FURTHER LAYOUT REQUIREMENTS, REFER TO ILLUSTRATIONS IN THE PERMIT HANDBOOK. DRIVEWAYS SHALL BE REPLACED IN KIND, UNLESS OTHERWISE NOTED ON THE PLANS.
2. COMMERCIAL DRIVEWAYS SHALL BE CONSTRUCTED WITH CONCRETE CURB, TYPE B RETURNS EXCEPT WHEN THE SIDEWALK EDGE IS 4 FEET OR LESS FROM THE BACK OF CURB, CONSTRUCT A FLARE DRIVEWAY WITHOUT CURB.
3. COMBINATION CONCRETE CURB & GUTTER SHALL BE MEASURED STRAIGHT ACROSS THE DRIVEWAY. NO ADDITIONAL COMPENSATION WILL BE ALLOWED FOR THE CURB & GUTTER TRANSITION.
4. 1" PREFORMED EXPANSION JOINT FILLER WILL NOT BE PAID SEPARATELY, BUT SHALL BE CONSIDERED INCLUDED IN THE COST OF THE P.C.C. DRIVEWAY PAVEMENT OR P.C.C. SIDEWALK.
5. WHEN THE P.C.C. SIDEWALK EXTENDS THROUGH THE DRIVEWAY, THE THICKNESS OF THE SIDEWALK IN THE DRIVEWAY AREA SHALL BE THE SAME AS THE DRIVEWAY THICKNESS. SIDEWALK WILL BE PAID FOR AS P.C.C. SIDEWALK OF THE THICKNESS SPECIFIED. SIDEWALK CROSS SLOPE THRU DRIVEWAY AREA TO BE A MAXIMUM OF 1:50.
6. ALL DRIVEWAY CONSTRUCTION WITHIN THE EXISTING OR PROPOSED RIGHT-OF-WAY SHALL BE PORTLAND CEMENT CONCRETE DRIVEWAY PAVEMENT. CONSTRUCTION BEYOND THIS LIMIT SHALL BE CONCRETE FOR EXISTING CONCRETE DRIVEWAYS AND BITUMINOUS FOR EXISTING AGGREGATE OR BITUMINOUS DRIVEWAYS.

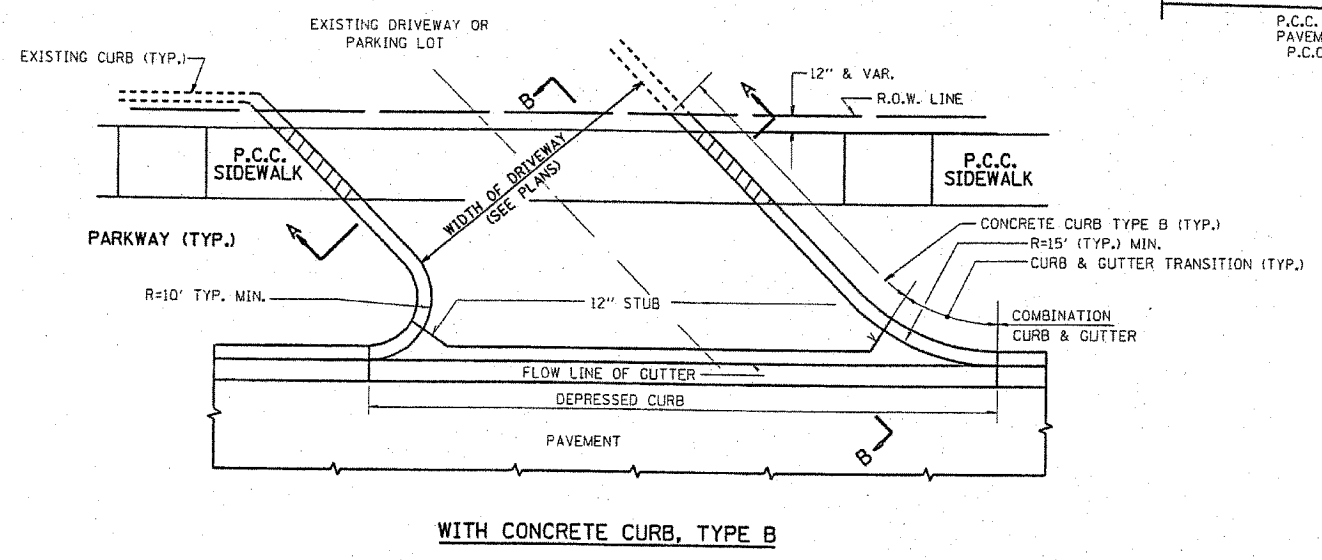
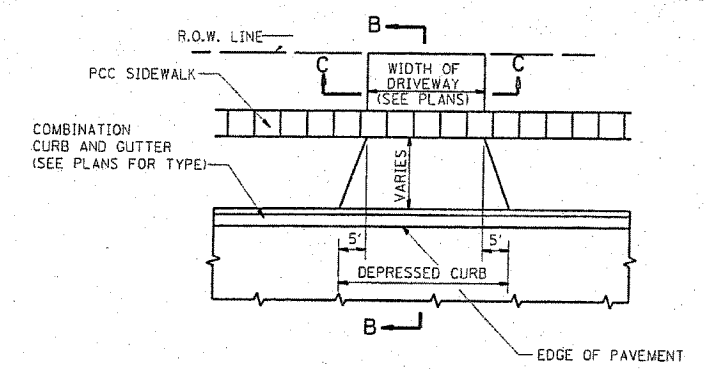
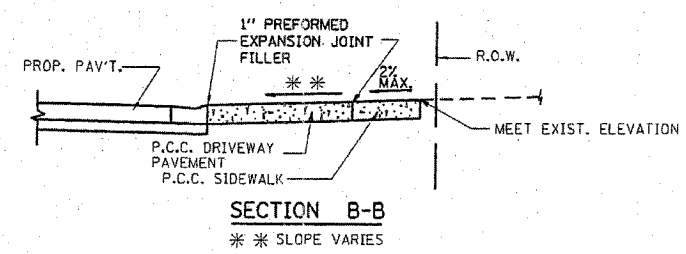
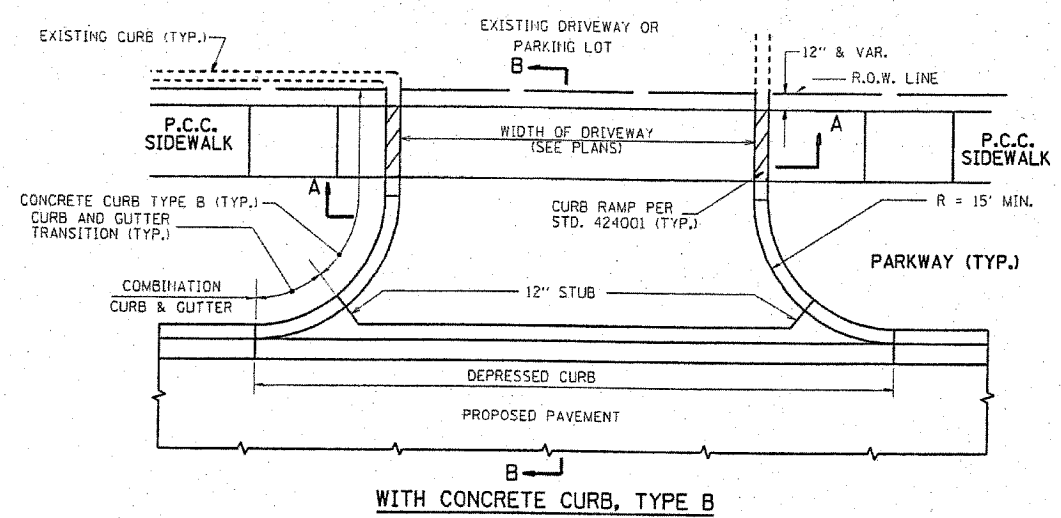
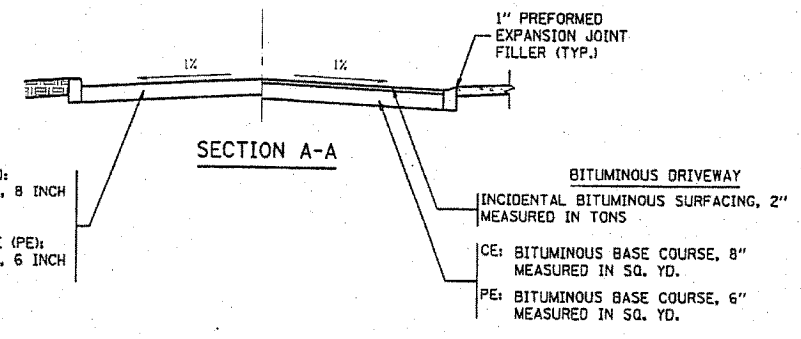

RIGID DRIVEWAY
 COMMERCIAL ENTRANCE (CE):
 P.C.C. DRIVEWAY PAVEMENT, 8 INCH
 MEASURED IN SQ. YD.
 NON-COMMERCIAL ENTRANCE (PE):
 P.C.C. DRIVEWAY PAVEMENT, 6 INCH
 MEASURED IN SQ. YD.

BITUMINOUS DRIVEWAY
 INCIDENTAL BITUMINOUS SURFACING, 2"
 MEASURED IN TONS
 CE: BITUMINOUS BASE COURSE, 8"
 MEASURED IN SQ. YD.
 PE: BITUMINOUS BASE COURSE, 6"
 MEASURED IN SQ. YD.

ALL DIMENSIONS ARE IN INCHES
 UNLESS OTHERWISE NOTED

REVISIONS	
NAME	DATE

ILLINOIS DEPARTMENT OF TRANSPORTATION

DRIVEWAY DETAILS
 VILLAGE OF CLERENDON HILLS

SCALE: NONE
 DATE: 27-APR-2005
 DRAWN BY: E.D.
 CHECKED BY: D.G.

