

P.A. NO.	SECTION	COUNTY	TOTAL SHEETS	SHEET NO.
350	3321-18s	Cook	24	17
STA.	TO STA.			
FED. ROAD DIST. NO.	ILLINOIS	FED. AID PROJECT		

62430

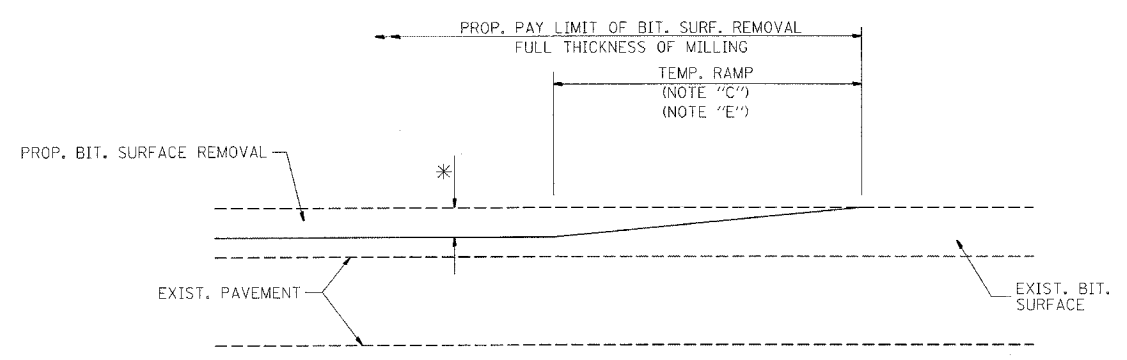

MILLED TEMPORARY RAMP
(FOR BUTT JOINT AND BIT. TAPER SEE DETAIL BELOW)

OPTION 1

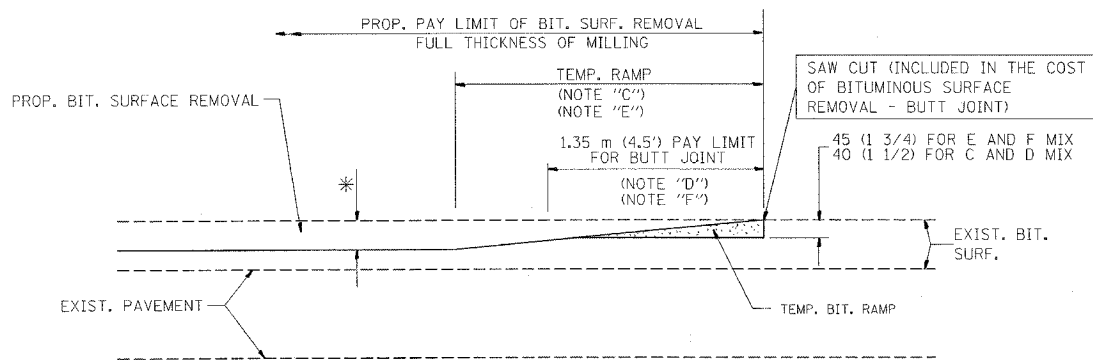

BITUMINOUS CONSTRUCTED TEMPORARY RAMP
(FOR BUTT JOINT AND BIT. TAPER SEE DETAIL BELOW)

OPTION 2
TYPICAL TEMPORARY RAMP

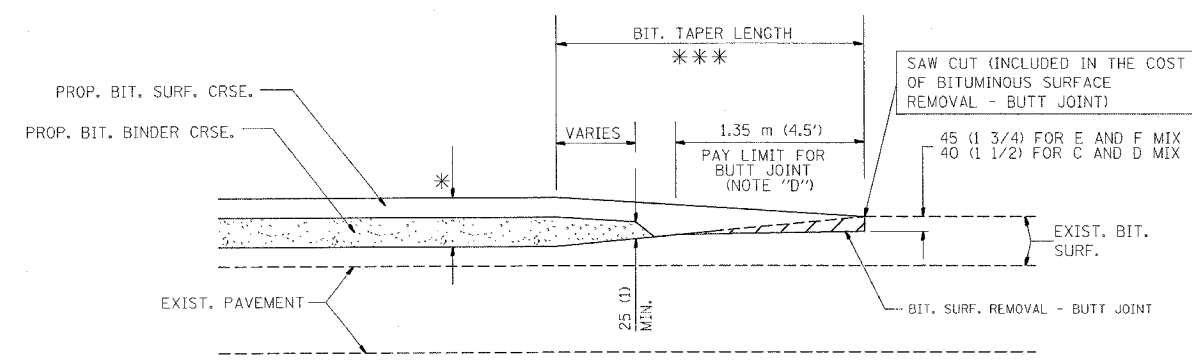

BUTT JOINT AND BITUMINOUS TAPER

TYPICAL BUTT JOINT AND BITUMINOUS TAPER FOR MILLING AND RESURFACING

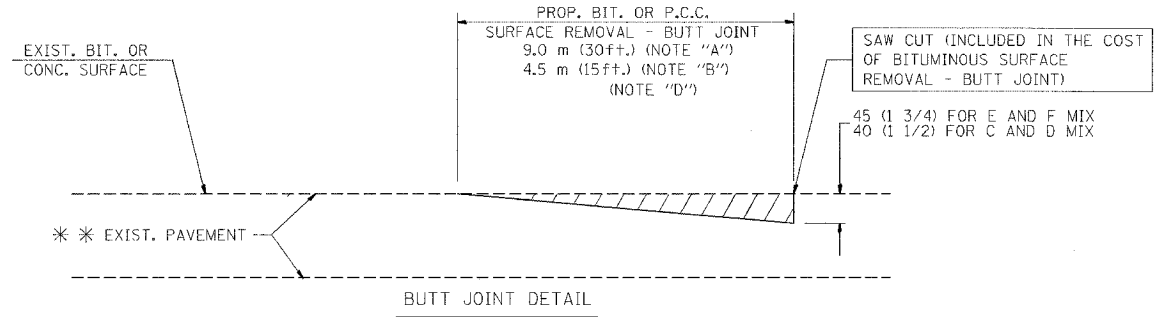

BUTT JOINT DETAIL

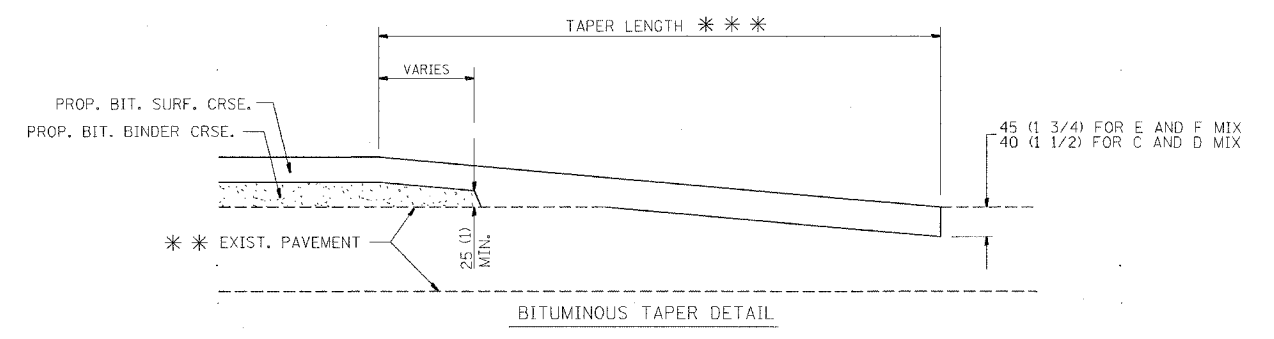

BITUMINOUS TAPER DETAIL

TYPICAL BUTT JOINT AND BITUMINOUS TAPER FOR RESURFACING ONLY

*** PC CONCRETE, BITUMINOUS OR BITUMINOUS RESURFACED PAVEMENT.

NOTES

- A: MAINLINE ROADWAYS AND MAJOR SIDE ROADS.
 - B: MINOR SIDE ROADS.
 - C: THE TEMP. RAMP SHALL BE CONSTRUCTED IMMEDIATELY UPON REMOVAL OF THE EXISTING BITUMINOUS SURFACE.
 - D: THE BUTT JOINT SHALL BE CONSTRUCTED IMMEDIATELY PRIOR TO PLACING THE PROPOSED BITUMINOUS COURSES.
 - E: TAPER THE TEMP. RAMP AT A RATE OF 900 (3 ft.) PER INCH OF MILLING THICKNESS.
 - F: INSTALLATION AND REMOVAL OF THE 1.35 m (4.5') TEMP. BIT. RAMP WILL BE PAID AS "BITUMINOUS SURFACE REMOVAL - BUTT JOINT".
 - G: SEE ARTICLE 406.18 AND 406.24 OF THE STANDARD SPECIFICATIONS FOR "BITUMINOUS AND PCC SURFACE REMOVAL, BUTT JOINT".
- *** SEE TYPICAL SECTIONS FOR MILLING THICKNESS.
- *** 6.1 m (20') PER 25 (1) RESURFACING (NOTE "A")
3.0 m (10') PER 25 (1) RESURFACING (NOTE "B")

ALL DIMENSIONS ARE IN MILLIMETERS (INCHES) UNLESS OTHERWISE SHOWN.

BASIS OF PAYMENT:

THE BUTT JOINT WILL BE PAID FOR PER SQUARE METER (SQUARE YARD.) AS "BITUMINOUS SURFACE REMOVAL - BUTT JOINT" OR AS "PORTLAND CEMENT CONCRETE SURFACE REMOVAL - BUTT JOINT".

REVISIONS	
NAME	DATE
M. DE YONG	6-13-90
M. DE YONG	7-3-90
M. DE YONG	3-27-92
R. SHAH	09/09/94
R. SHAH	10/25/94
A. ABBAS	03/21/97
M. GOMEZ	04/06/01

ILLINOIS DEPARTMENT OF TRANSPORTATION

BUTT JOINT AND BITUMINOUS TAPER DETAILS

SCALE: NONE
DATE PLOTTED: 11/12/2005

DRAWN BY
CHECKED BY

BD400-05 (V1-BD32)

REVISION DATE: 04/06/01