

F.A.I. RTE.	SECTION	COUNTY	TOTAL SHEETS	SHEET NO.
90	*	COOK	82	7
STA. TO STA.				
FED. ROAD DIST. NO. 1	ILLINOIS	FED. AID PROJECT		
* (1012, 1214, 1415, & 1517) RS-3				

62746

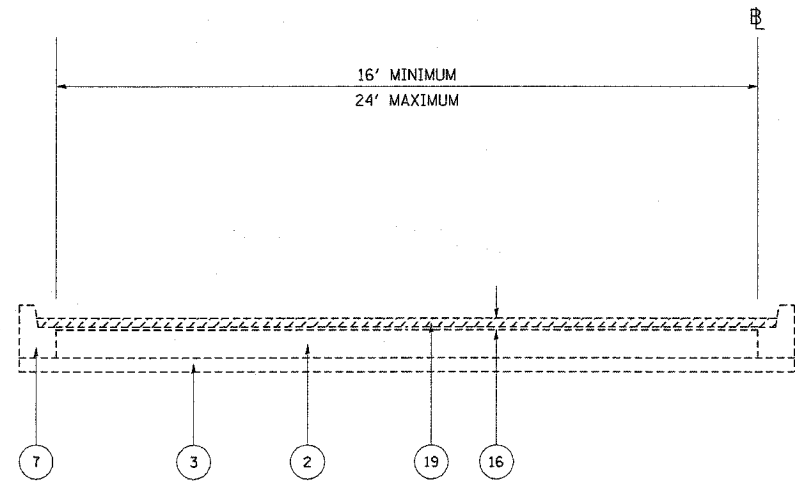

**KENNEDY EXPRESSWAY
EXISTING TYPICAL SECTION
RAMPS**

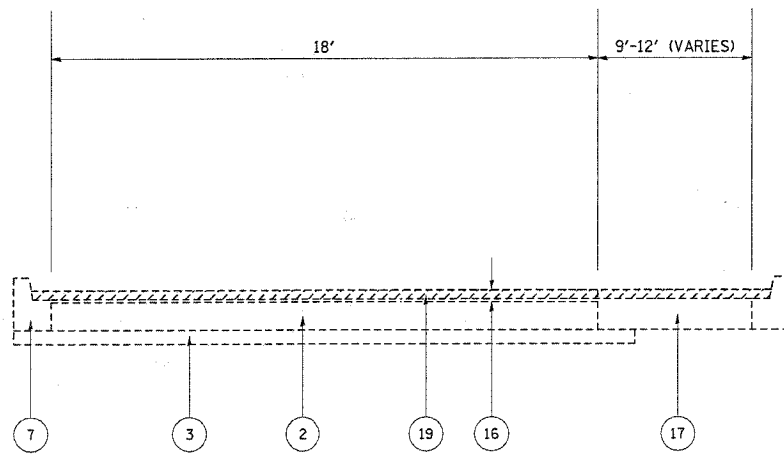

**KENNEDY EXPRESSWAY
EXISTING TYPICAL SECTION
CUMBERLAND ENTRANCE RAMP #4**

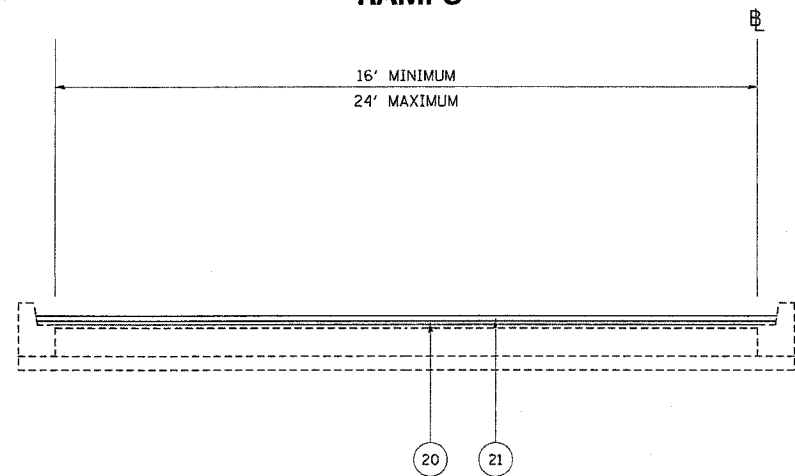

**KENNEDY EXPRESSWAY
PROPOSED TYPICAL SECTION
RAMPS**

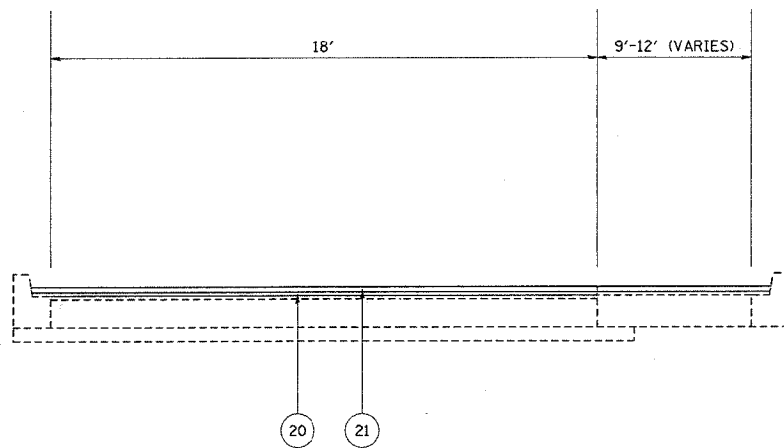

**KENNEDY EXPRESSWAY
PROPOSED TYPICAL SECTION
CUMBERLAND ENTRANCE RAMP #4**

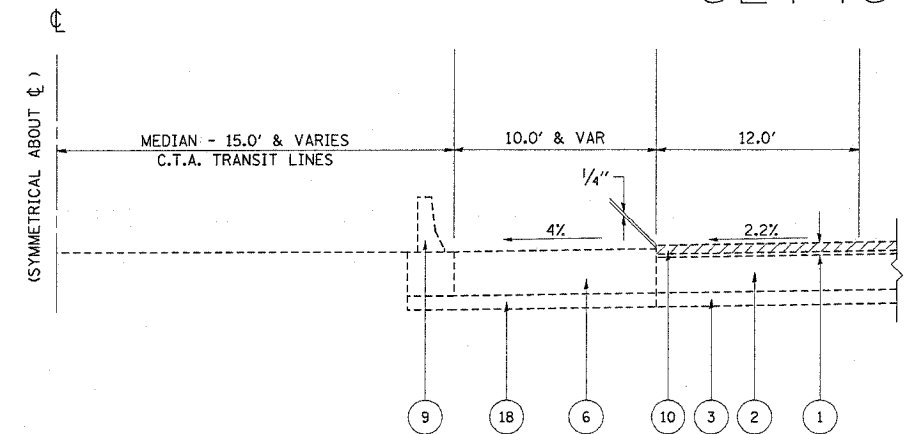

**KENNEDY EXPRESSWAY
STA. 3610+38.00 TO STA. 3646+77.10
EXISTING TYPICAL SECTION**

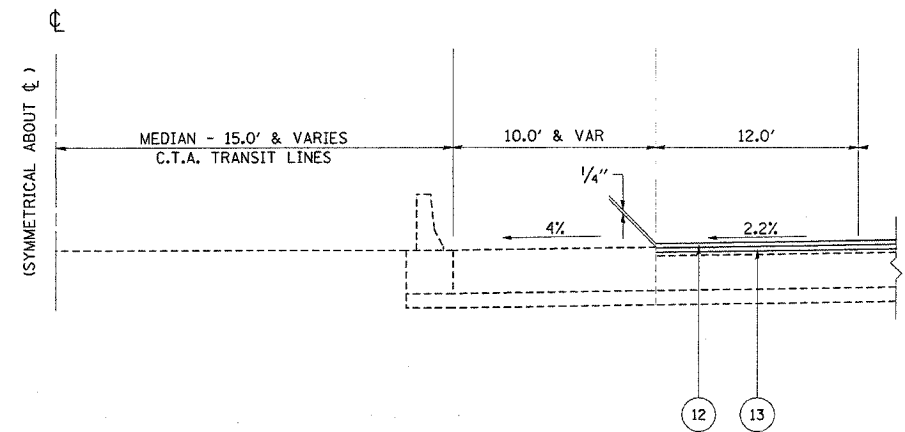

**KENNEDY EXPRESSWAY
STA. 3610+38.00 TO STA. 3646+77.10
PROPOSED TYPICAL SECTION**

2006

LEGEND

- | | | | |
|----|---|----|--|
| 1 | EXISTING BITUMINOUS CONCRETE COURSE, ± 4¾" | 13 | PROPOSED STONE MATRIX ASPHALT, BINDER COURSE, 2" |
| 2 | EXISTING PORTLAND CEMENT CONCRETE PAVEMENT, 10" (STD. REINFORCED) | 14 | PROPOSED BITUMINOUS CONCRETE SURFACE COURSE, SUPERPAVE, MIX"D", N70, 2" |
| 3 | EXISTING AGGREGATE SUB-BASE, 6" | 16 | EXISTING BITUMINOUS CONCRETE COURSE, ± 2½" |
| 6 | EXISTING P.C.C. SHOULDER, 13" | 17 | EXISTING BITUMINOUS SHOULDER, 10" |
| 7 | EXISTING COMBINATION CONCRETE CURB AND GUTTER, TYPE VARIES (SEE NOTE 2) | 18 | EXISTING SUB-BASE GRANULAR MATERIAL, TYPE B, 6" |
| 9 | EXISTING BARRIER WALL | 19 | PROPOSED BITUMINOUS SURFACE REMOVAL, 2¼" |
| 10 | PROPOSED BITUMINOUS SURFACE REMOVAL, 4" | 20 | PROPOSED POLYMERIZED LEVELING BINDER (MACHINE METHOD), SUPERPAVE, 1L-4.75, N50, ¾" |
| 12 | PROPOSED STONE MATRIX ASPHALT, SURFACE COURSE, 2" | 21 | PROPOSED BITUMINOUS CONCRETE SURFACE COURSE, SUPERPAVE, MIX"D", N70, 1½" |

NOTES

1. MATCH EXISTING ELEVATIONS AT EDGE OF SHOULDER.
2. SOME LOCATIONS DO NOT HAVE CURB AND GUTTER. ALSO SHOULDER WIDTH VARIES FROM 10.0' MAXIMUM TO 4.0' MINIMUM.
3. MATCH EXISTING ELEVATIONS AT EDGE OF PAVEMENT.

REVISIONS		ILLINOIS DEPARTMENT OF TRANSPORTATION
NAME	DATE	
		KENNEDY EXPRESSWAY TYPICAL SECTIONS
SCALE: VERT. NONE	DRAWN BY EWK	CHECKED BY
DATE 4/28/2005		