

62746

F.A.I. RTE.	SECTION	COUNTY	TOTAL SHEETS	SHEET NO.
90	*	COOK	82	58
STA. _____		TO STA. _____		
FED. ROAD DIST. NO. - ILLINOIS FED. AID PROJECT				
*(1012, 1214, 1415, & 1517) R5-3				

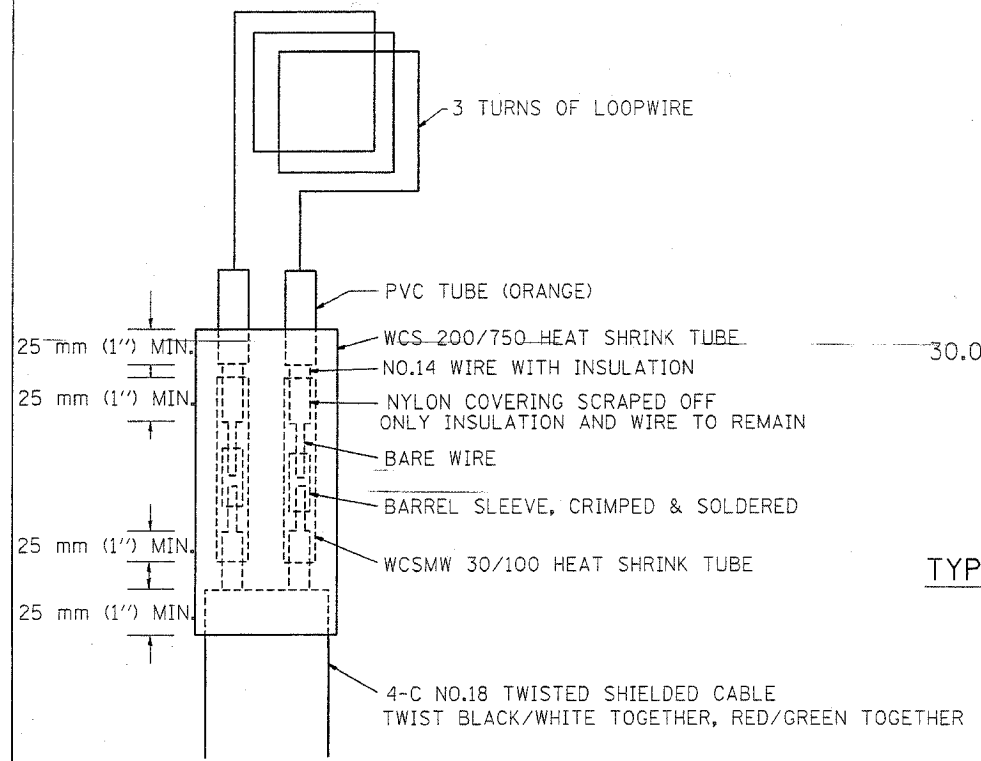

MINIMUM 25 mm (1") HEAT SHRINK TUBING OVERLAP ON WIRE, PVC & SHIELDED CABLE TO FORM WATER TIGHT SEAL

LOOP-SPLICING REQUIREMENTS

WIDTH (W)	WIDTH (S)
3.7 m (12')	2.5 m (8')
4.0 m (13')	2.8 m (9')
4.3 m (14')	3.1 m (10')
4.6 m (15')	3.4 m (11')
4.9 m (16')	3.7 m (12')
5.2 m (17')	4.0 m (13')
5.5 m (18')	4.3 m (14')
5.8 m (19')	4.6 m (15')
6.1 m (20')	4.9 m (16')
6.4 m (21')	5.2 m (17')
6.7 m (22')	5.5 m (18')
7.0 m (23')	5.8 m (19')
7.3 m (24')	6.1 m (20')
7.6 m (25')	6.4 m (21')

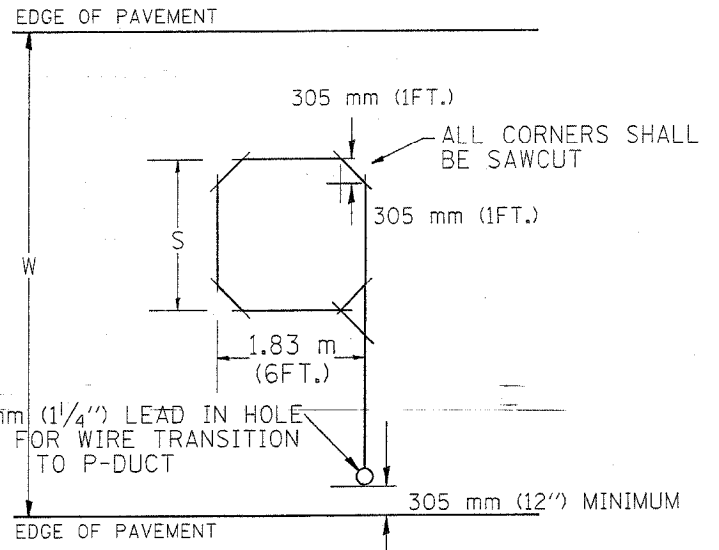

TYPICAL "S" FT. BY 1.83 m (6FT.) INDUCTION LOOP SAWCUT LAYOUT FOR RAMPS

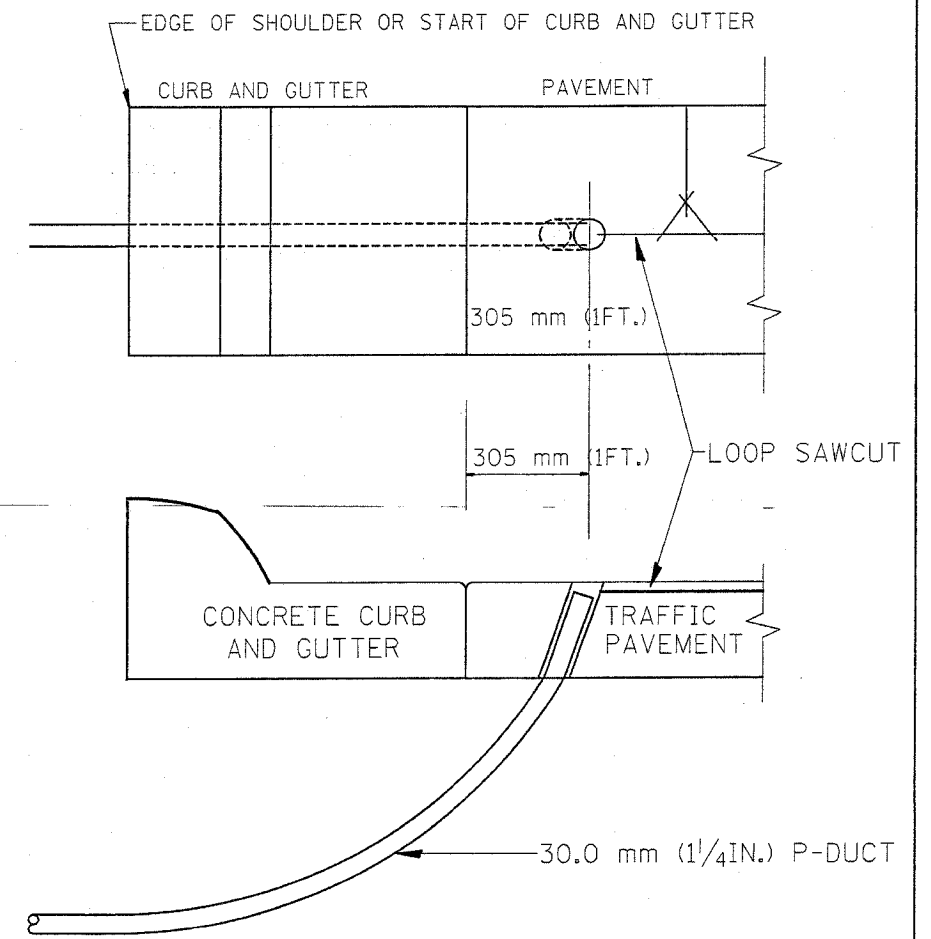

CURB AND GUTTER LOOP LEAD-IN TRANSITION DETAIL

NOTES

1. EACH LOOP SHALL BE SPLICED TO A 4-C NO.18 TWISTED SHIELDED LEAD IN WHEN 45 m (150FT.) OR MORE FROM CABINET.
2. LOOPS SHALL BE SPLICED IN HANDHOLES ONLY, OTHERWISE WRITTEN PERMISSION SHALL BE OBTAINED FROM TSC ENGINEER.
3. LOOPS SHALL NOT BE SPLICED IN SERIES.
4. EACH LOOP LEAD IN SHALL BE IDENTIFIED AND PERMANENTLY COLOR CODED IN THE COREHOLE, HANDHOLE & CABINETS THRU WHICH THEY ENTER OR PASS AND TAGGED WITH THE CORRECT NOMENCLATURES.

REVISIONS	
NAME	DATE
R.L.	6/94
T.C.	11/95
R.L.	05/96
T.C.	10/96

ILLINOIS DEPARTMENT OF TRANSPORTATION
TRAFFIC SYSTEMS CENTER
**RECTANGULAR INDUCTION LOOP
TYPICAL**

SCALE: VERT. NONE
HORIZ. _____
DATE 6-22-94
DRAWN BY G.M.
CHECKED BY R.L.