

F.A. RTE.	SECTION	COUNTY	TOTAL SHEETS	SHEET NO.
			1360	860A
STA.		TO STA.		
FED. ROAD DIST. NO.	ILLINOIS	FED. AID PROJECT		

\* THE BAR SPLICER SHALL BE CAPABLE OF DEVELOPING A MINIMUM OF 125% OF THE YIELD STRENGTH OF A #20 BAR

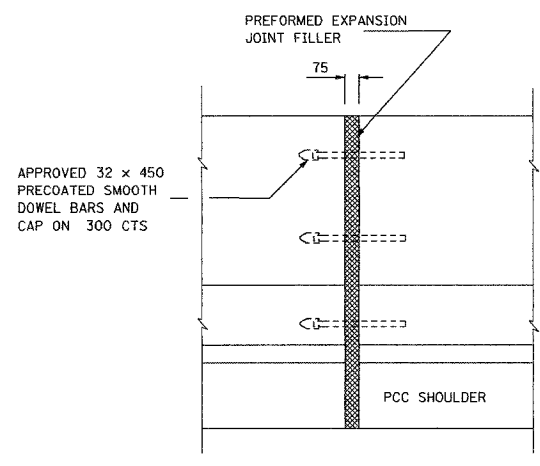

EXPANSION JOINT

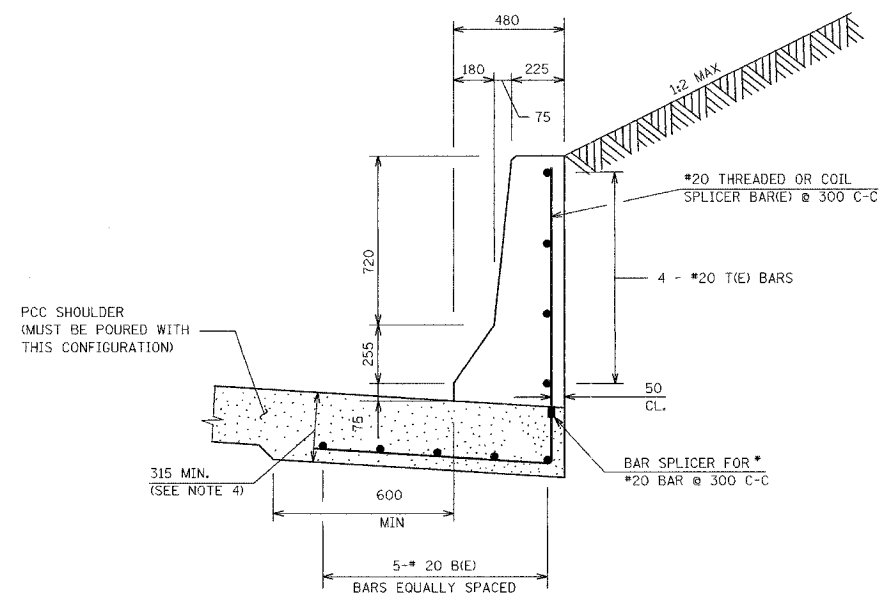

CONCRETE BARRIER, SINGLE FACE (MODIFIED)  
CUT SECTION

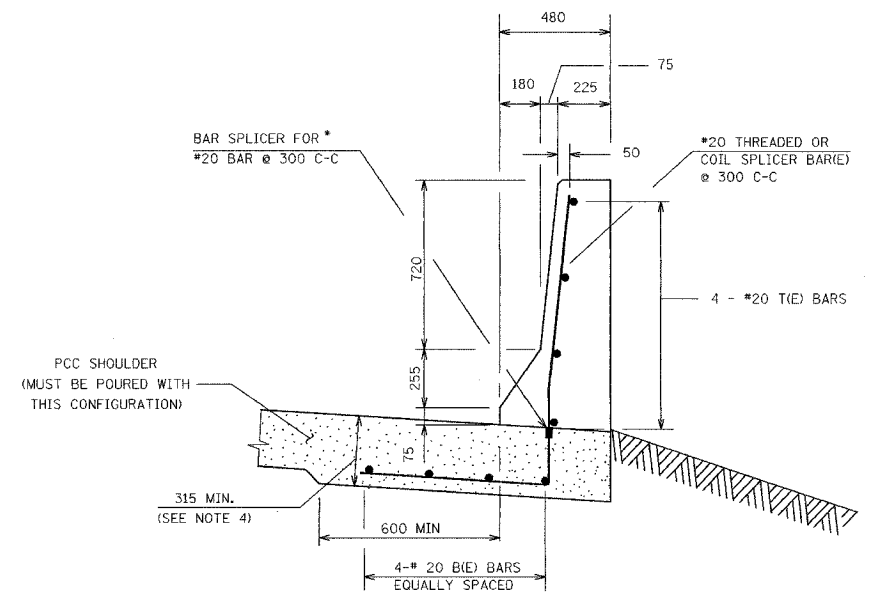

CONCRETE BARRIER, SINGLE FACE (MODIFIED)  
FILL SECTION

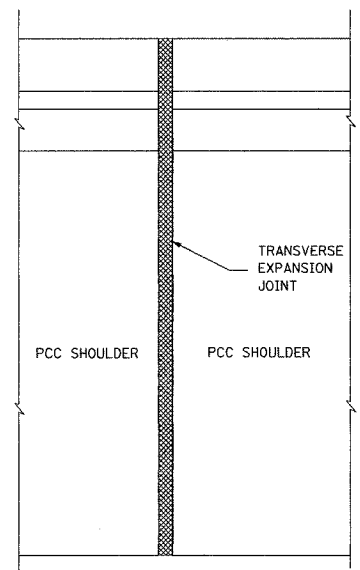

PLAN

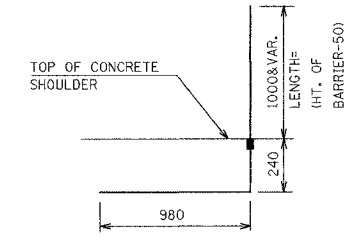

BAR SPLICER DETAIL  
CUT SECTION

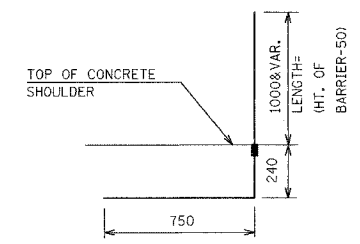

BAR SPLICER DETAIL  
FILL SECTION

CUT SECTION

REINFORCING BARS 6.1 m SECTION				
BAR	NO.	SIZE	LENGTH	SHAPE
B(E)	5	#20	6.00 m	—
T(E)	4	#20	6.00 m	—
REINFORCING BARS (EPOXY COATED)			Kg	128
BAR SPLICERS			EACH	21

\*\* LONGITUDINAL BARS SHOULD NOT EXTEND THROUGH JOINTS.

FILL SECTION

REINFORCING BARS 6.1 m SECTION				
BAR	NO.	SIZE	LENGTH	SHAPE
B(E)	4	#20	6.00 m	—
T(E)	4	#20	6.00 m	—
REINFORCING BARS (EPOXY COATED)			Kg	114
BAR SPLICERS			EACH	21

\*\* LONGITUDINAL BARS SHOULD NOT EXTEND THROUGH JOINTS.

NOTES:

- FOR ADDITIONAL SHOULDER DETAILS SEE I-74 PROJECT STDS 483001-I74 AND 601001-I74
- A 25 RADIUS CAN BE SUBSTITUTED FOR THE 13 CHAMFER AT THE TOP OF THE BARRIER WALL.
- THE FURNISHING AND PLACING OF REINFORCING BARS AND BAR SPLICERS AND THE THICKENED PCC SHOULDER WHEN REQUIRED SHALL BE INCLUDED IN THE COST OF THE CONCRETE BARRIER OF THE TYPE SPECIFIED.
- ALL REINFORCING BARS, BAR SPLICERS, TIE BARS AND DOWEL BARS SHALL BE SEATED IN THE FINAL POSITION PRIOR TO THE CONCRETE OPERATIONS. BARS CANNOT BE MUCKED INTO PLACE.
- TRANSVERSE EXPANSION JOINT THRU THE PAVEMENT AND THE SHOULDER SHALL BE EXTENDED THRU THE CONCRETE BARRIER.

ALL DIMENSIONS ARE IN MILLIMETER UNLESS OTHERWISE SHOWN

REVISIONS	
NAME	DATE
EXPANSION JOINT	10/7/03
REVISED SHEET	MAY 27 2005

ILLINOIS DEPARTMENT OF TRANSPORTATION  
I-74 PROJECT STANDARD 637002-I74  
CONCRETE BARRIER,  
SINGLE FACE (MODIFIED)

DRAWN BY  
DATE 08/15/02  
CHECKED BY