

SCHEDULE OF TRAFFIC SIGNAL ITEMS

UNIT	ITEM	UNIT	WB RAMP	EB RAMP	BLACK JACK	TEMP TRAFFIC SIGNALS	INTER CONNECT	TOTAL QTY.
• 80500205	SERVICE INSTALLATION, TYPE B (MODIFIED)	EACH	1.0	0.0	1.0	0.0	0.0	2.0
• 81400400	CONCRETE HANDHOLE	EACH	3.0	0.0	4.0	0.0	13.0	20.0
• 81400600	CONCRETE DOUBLE HANDHOLE	EACH	1.0	0.0	1.0	0.0	0.0	2.0
• 82102400	LUMINAIRE, SODIUM VAPOR, HORIZONTAL MOUNT, 400 WATT	EACH	3.0	0.0	4.0	0.0	0.0	7.0
• 85700200	FULL-ACTUATED CONTROLLER AND TYPE IV CABINET	EACH	1.0	0.0	1.0	0.0	0.0	2.0
• 86400100	TRANSCIEVER - FIBER OPTIC	EACH	1.0	0.0	1.0	0.0	0.0	2.0
• 88200110	TRAFFIC SIGNAL BACKPLATE LOUVERED	EACH	8.0	0.0	11.0	0.0	0.0	19.0
• 88800100	PEDESTRIAN PUSH-BUTTON	EACH	0.0	0.0	2.0	0.0	0.0	2.0
• 89000200	TEMPORARY TRAFFIC SIGNAL INSTALLATION	EACH	0.0	0.0	0.0	2.0	0.0	2.0
• 89502375	REMOVE EXISTING TRAFFIC SIGNAL EQUIPMENT	EACH	0.0	0.0	0.0	1.0	0.0	1.0
• 89502380	REMOVE EXISTING HANDHOLE	EACH	0.0	0.0	0.0	5.0	0.0	5.0
• 89502385	REMOVE EXISTING CONCRETE FOUNDATION	EACH	0.0	0.0	0.0	5.0	0.0	5.0
• M8100260	CONDUIT IN TRENCH, 50 MM DIA, PVC	METER	23.0	0.0	70.0	0.0	2719.0	2812.0
• M8100280	CONDUIT IN TRENCH, 75 MM DIA, PVC	METER	25.0	0.0	11.0	0.0	0.0	36.0
• M8100290	CONDUIT IN TRENCH, 90 MM DIA, PVC	METER	22.0	0.0	42.0	0.0	0.0	64.0
• M8101450	CONDUIT PUSHED, 50 MM DIA, PVC	METER	43.0	0.0	64.0	0.0	0.0	107.0
• M8101480	CONDUIT PUSHED, 90 MM DIA, PVC	METER	43.0	0.0	64.0	0.0	0.0	107.0
• M8110190	CONDUIT ATTACHED TO STRUCTURE, 90MM DIA., GALVANIZED STEEL	METER	0.0	0.0	6.1	0.0	0.0	6.1
• M8150200	TRENCH AND BACKFILL FOR ELECTRICAL WORK	METER	70.0	0.0	80.0	0.0	1751.0	1901.0
• M8170040	ELECTRIC CABLE IN CONDUIT, 600 V (XLP-TYPE USE) 1/C NO. 6	METER	24.0	0.0	27.0	0.0	0.0	51.0
• M8731220	LIGHT POLE, GALVANIZED STEEL, 13.5M M.H., 4.5 M DAVIT ARM	EACH	1.0	0.0	0.0	0.0	0.0	1.0
• M8731240	ELECTRIC CABLE IN CONDUIT, SIGNAL NO. 14 3C	METER	0.0	0.0	63.0	0.0	0.0	63.0
• M8731240	ELECTRIC CABLE IN CONDUIT, SIGNAL NO. 14 5C	METER	260.0	0.0	593.0	0.0	0.0	853.0
• M8731250	ELECTRIC CABLE IN CONDUIT, SIGNAL NO. 14 7C	METER	191.0	0.0	53.0	0.0	0.0	244.0
• M8750510	TRAFFIC SIGNAL POST, GALVANIZED STEEL 4.85 METER	EACH	3.0	0.0	0.0	0.0	0.0	3.0
• M8770760	STEEL COMBINATION MAST ARM ASSEMBLY AND POLE, 11.58 METER	EACH	0.0	0.0	2.0	0.0	0.0	2.0
• M8780100	CONCRETE FOUNDATION, TYPE A	METER	2.7	0.0	0.0	0.0	0.0	2.7
• M8780200	CONCRETE FOUNDATION, TYPE D	METER	1.1	0.0	1.1	0.0	0.0	2.2
• M8780400	CONCRETE FOUNDATION, TYPE E, 750 MM DIAMETER	METER	3.0	0.0	0.0	0.0	0.0	3.0
• MX871055	FIBER OPTIC CABLE IN CONDUIT, NO. 62.5/125, MM12F SM12F	METER	0.0	0.0	0.0	0.0	1516.0	1516.0
• MX877017	STEEL COMBINATION MAST ARM ASSEMBLY AND POLE, 15.850 METER	EACH	0.0	0.0	1.0	0.0	0.0	1.0
• MX877020	STEEL COMBINATION MAST ARM ASSEMBLY AND POLE, 16.76 METER	EACH	2.0	0.0	1.0	0.0	0.0	3.0
• MX878030	CONCRETE FOUNDATION, TYPE E, 900 MM DIAMETER	METER	9.2	0.0	16.0	0.0	0.0	25.2
• X0323481	VIDEO VEHICLE DETECTION, 4 CAMERAS	EACH	1.0	0.0	1.0	0.0	0.0	2.0
• X0324134	BATTERY BACKUP SYSTEM WITH CABINET	EACH	1.0	1.0	1.0	0.0	0.0	3.0
• X8800020	SIGNAL HEAD, LED, 1-FACE, 3-SECTION, MAST ARM MOUNTED	EACH	7.0	0.0	11.0	0.0	0.0	18.0
• X8800035	SIGNAL HEAD, LED, 1-FACE, 3-SECTION, BRACKET MOUNTED	EACH	4.0	0.0	3.0	0.0	0.0	7.0
• X8800038	SIGNAL HEAD, LED, 1-FACE, 4-SECTION, MAST ARM MOUNTED	EACH	1.0	0.0	0.0	0.0	0.0	1.0
• X8800040	SIGNAL HEAD, LED, 1-FACE, 5-SECTION, BRACKET MOUNTED	EACH	3.0	0.0	1.0	0.0	0.0	4.0
• X8810610	PEDESTRIAN SIGNAL HEAD, LED, 1-FACE, BRACKET MOUNTED	EACH	0.0	0.0	2.0	0.0	0.0	2.0

• SEE SPECIAL PROVISIONS

CONTRACT 11 TRAFFIC SIGNAL CONSTRUCTION NOTES

- THE RED SECTIONS OF THE SIGNAL HEADS SHARING THE SAME MAST ARM SHALL BE LEVEL WITH ONE ANOTHER AND MAINTAIN A 4.88 METER (16') MINIMUM CLEARANCE.
- THE PROPOSED MAST ARM MOUNTED TRAFFIC SIGNAL HEADS SHALL BE MOUNTED DIRECTLY OVER THE CENTER OF THEIR RESPECTIVE LANES, UNLESS INDICATED OTHERWISE ON THE PLANS.
- ALL TRAFFIC SIGNAL POSTS ARE TO BE GALVANIZED STEEL, SCHEDULE 40.
- ALL BRACKET MOUNTS AND ASSOCIATED PIPES ARE TO BE UNPAINTED ALUMINUM, SCHEDULE 80.
- ALL SIGNAL CABINETS SHALL BE UNPAINTED ALUMINUM
- ALL TRAFFIC SIGNAL HEADS AND PEDESTRIAN SECTIONS SHALL BE 300-MILLIMETER (12") WITH LED LENSES.
- BACKPLATES SHALL BE POLYCARBONATE WITH A DEEP BACK FLANGE.
- PROPOSED HANDHOLES SHALL BE CAST IN PLACE CONCRETE HANDHOLES. THIS WORK SHALL BE PAID FOR AS CONCRETE HANDHOLES.
- THE HANDHOLE SHALL BE CONSTRUCTED SO THAT THE TOP OF THE FRAME WILL BE FLUSH WITH THE SURFACE OF THE MEDIAN OR GROUND LINE.
- THE DOUBLE HANDHOLE SHALL NOT BE USED IN LIEU OF THE CONTROLLER FOUNDATION PAD.
- THE TRAFFIC SIGNAL CONTROLLER SHALL BE ORIENTED SO THAT THE DOOR IS FACING AWAY FROM TRAFFIC.
- THE CONTRACTOR MAY ELECT TO PUSH A CONDUIT THAT IS SHOWN TO BE TRENCHED ON THE PLANS. THIS WORK WILL BE MEASURED FOR PAYMENT AND PAID FOR AS CONDUIT IN TRENCH OF THE TYPE AND SIZE SPECIFIED AND TRENCH AND BACKFILL FOR ELECTRICAL WORK.
- COILABLE POLYETHYLENE DUCT MAY BE SUBSTITUTED FOR PVC CONDUIT PUSHED OR TRENCHED.
- A 12GA, STRANDED THHN, INSULATED ORANGE TRACER WIRE IS TO BE PULLED INTO ALL CONDUITS THAT CONTAIN FIBER OPTIC CABLE. THIS WORK SHALL BE DONE AT THE SAME TIME THE FIBER OPTIC CABLE IS PULLED. THERE SHALL BE NO ADDITIONAL COMPENSATION FOR THIS WORK.
- THE LOCATIONS FOR HANDHOLES AND MAST ARM FOUNDATIONS ARE PROVIDED FOR REFERENCE ONLY. THE ENGINEER OF TRAFFIC SHALL BE NOTIFIED FOR LOCATION VERIFICATION BEFORE INSTALLATION.
- ALL REMOVAL AND SURPLUS ITEMS SHALL BE DISPOSED OF IN ACCORDANCE WITH ARTICLE 202.03 OF THE STANDARD SPECIFICATIONS.
- ANY MAINTENANCE OF EXISTING TRAFFIC SIGNALS SHALL BE CONSIDERED AS EXTRA WORK AND SHALL BE PAID FOR ACCORDING TO ARTICLE 109.04.
- ALL MAST ARMS, SIGNAL HEADS, POSTS AND LUMINAIRES REMOVED BE DELIVERED TO 6500 W RT 150, EDWARDS, IL. ALL CONTROLLER CABINETS AND OTHER REMOVAL ITEMS SHALL BE RETURNED TO 5826 N KNOXVILLE, PEORIA, IL 61614.
- THE CONTRACTOR SHALL VERIFY THE EXACT LOCATION OF ALL UNDERGROUND UTILITIES PRIOR TO BEGINNING CONSTRUCTION. CALL J.U.L.I.E. AT 800-892-0123.
- TRAFFIC SIGNAL HEADS SHALL BE PROPERLY COVERED WITH A SOLID BLACK COVER PRIOR TO INTERSECTION TURN-ON OR AS DIRECTED BY THE ENGINEER. THIS COST SHALL BE INCLUDED WITH THE COST OF THE ASSOCIATED SIGNAL PAY ITEMS.
- NO ADDITIONAL COMPENSATION WILL BE ALLOWED FOR PLACING CONDUIT AT GREATER THAN 600-MILLIMETER MINIMUM DEPTH TO AVOID OBSTACLES SUCH AS UNDERGROUND UTILITIES.
- THE ELECTRICAL CONDUCTORS FOR ALL TRAFFIC SIGNAL HEAD SHALL BE SOLID, SOFT COPPER.
- THE CONTRACTOR IS RESPONSIBLE FOR UNCOVERING OR HAND DIGGING AROUND UTILITIES AS NECESSARY. THE COST OF THIS WORK IS TO BE INCLUDED WITH THE TRENCH AND BACKFILL FOR ELECTRICAL WORK PAY ITEM.
- ALL HARDWARE SHALL BE TIGHTENED AND WELL SECURED. CABLES SHALL BE NEATLY WOUND IN HANDHOLES. CABLES SHALL BE NEATLY TRAINED IN THE CONTROLLER CABINET.
- ALL SIGNAL BASES SHALL BE LOCATED A MINIMUM OF 1.8 METERS FROM THE FACE OF CURB UNLESS OTHERWISE DIRECTED BY AN ENGINEER.
- ALL NEW TRAFFIC AND PEDESTRIAN SIGNAL WIRING SHALL EXTEND FROM CONTROLLER TO SIGNAL. SPLICES IN HANDHOLES WILL NOT BE ALLOWED.
- GROUND RODS SHALL BE SOLID COPPER ALLOY OR COPPER CLAD STEEL.
- ALL MAST ARM POLE BASES SHALL BE PROTECTED BY A STAINLESS STEEL MESH SCREENING AROUND THE BASE BOLTS TO PREVENT RODENT ENTRY. THE MESH SHALL BE SECURED TO THE BASE BY STAINLESS STEEL BANDING AS INCIDENTAL TO THE INDIVIDUAL MAST ARM ASSEMBLY PAY ITEM.
- THE CONTRACTOR SHALL CONTACT THE AMEREN CILCO PRIOR TO BEGINNING WORK TO OBTAIN THE UTILITY COMPANY REQUIREMENTS FOR THE SERVICE INSTALLATION.
- ALL HANDHOLE FRAMES AND RINGS SHALL BE GROUNDED AND BOUNDED TO THE TRAFFIC SIGNAL EQUIPMENT GROUNDING CONDUCTOR.
- MAST ARMS SHALL BE LOCATED INSIDE OF ISLANDS WITH A MINIMUM 5 FOOT CLEARANCE FROM THE MASS ARM TO THE FACE OF CURB.

F.A.I. RTE.	SECTION	COUNTY	TOTAL SHEETS	SHEET NO.
74	*	TAZEWELL	1366	315
STA.		TO STA.		
FED. ROAD DIST. NO. 4		ILLINOIS	FED. AID PROJECT	

• (90-11R-2)90(13,14,14-1)R-1

PEDESTRIAN CROSSING SIGN DETAIL

R10 - 4b

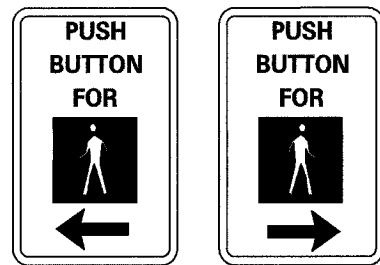

DIMENSIONS: 225 mm (9" TYP.) x 300 mm (12" TYP.)
 LENGEND AND BORDER: NON-REFLECTORIZED BLACK
 BACKGROUND: NON-REFLECTORIZED WHITE

ONE SIGN SHALL BE PROVIDED FOR EACH PUSH-BUTTON.
 ORIENTATION OF DIRECTIONAL ARROWS TO BE DETERMINED BY PUSH-BUTTON LOCATION

ALL MOUNTING HARDWARE SHALL BE STAINLESS STEEL CONSTRUCTION. ALL MOUNTING BOLTS SHALL BE HEX HEAD.

MATERIALS AND INSTALLATION OF THIS SIGN SHALL BE INCLUDED IN THE COST OF PEDESTRIAN PUSHBUTTON.

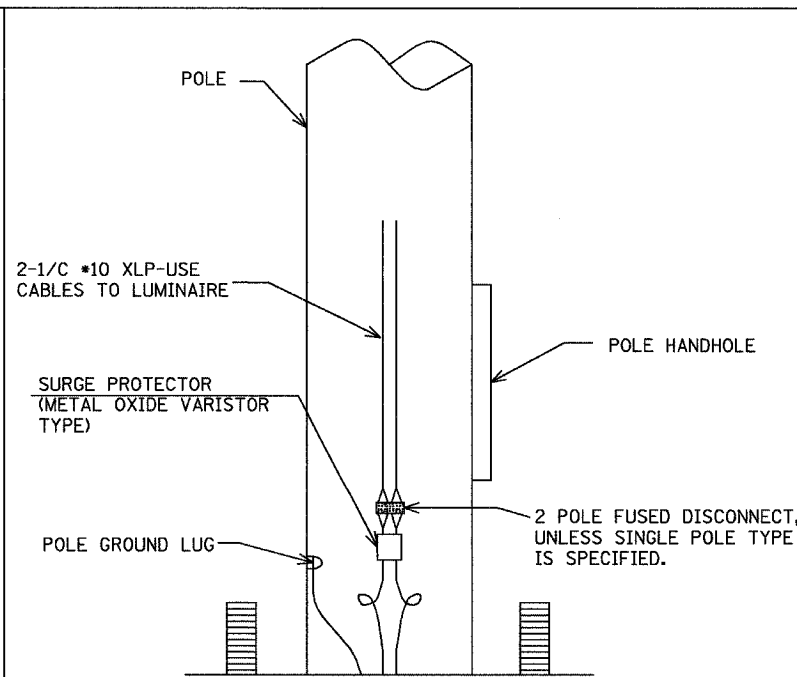

OVERHEAD LIGHTING ELECTRIC CABLE SHALL BE 2-1/2 *6 XLP/USE AND 1-1/2 *6 XLP/USE GREEN INSULATION (FOR GROUND) PER STANDARD 1076.01 (A).

UPDATED SCHEDULE

REVISIONS	
NAME	DATE
Δ	MAY 27 2005

ILLINOIS DEPARTMENT OF TRANSPORTATION

SUMMARY OF QUANTITIES AND CONSTRUCTION NOTES

SHEET 1 OF 13

DRAWN BY SAM

CHECKED BY CTH

DATE 12/20/04

