

F.A. RTE.	SECTION	COUNTY	TOTAL SHEETS	SHEET NO.
789	1T	MADISON	15	12
STA.	TO STA.			
FED. ROAD DIST. NO.	ILLINOIS	FED. AID PROJECT		
<b>CONTRACT NO.: 76648</b>				

60 50 40 30 20 10 0 10 20 30 40 50 60 70 80 90 100 110 120 130 140 150 160 170 180 190 200 210 220 230 240

525 520 515 510

219+00.00

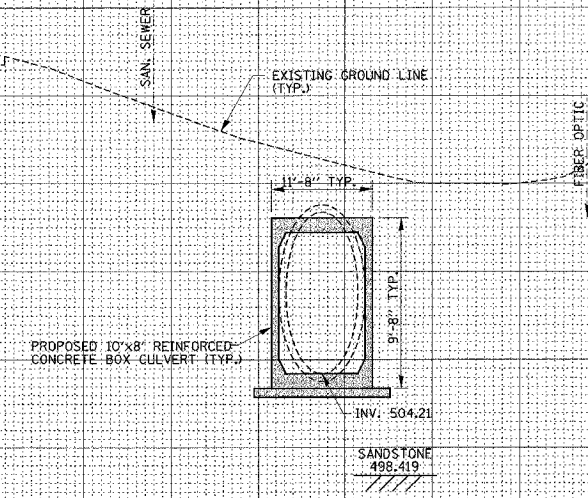

520 515

218+50.00

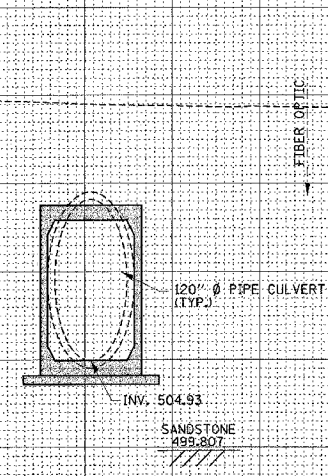

520 515

217+50.00

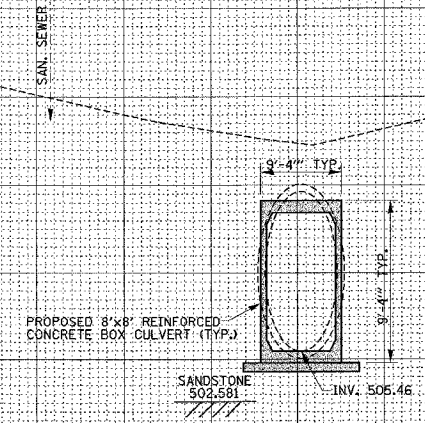

60 50 40 30 20 10 0 10 20 30 40 50 60 70 80 90 100 110 120 130 140 150 160 170 180 190 200 210 220 230 240

DATE \_\_\_\_\_  
BY \_\_\_\_\_  
SURVEYED \_\_\_\_\_  
PLOTTED \_\_\_\_\_  
NOTE BOOK \_\_\_\_\_  
AREAS CHECKED \_\_\_\_\_  
NO. \_\_\_\_\_

DATE \_\_\_\_\_  
BY \_\_\_\_\_  
SURVEYED \_\_\_\_\_  
PLOTTED \_\_\_\_\_  
NOTE BOOK \_\_\_\_\_  
AREAS CHECKED \_\_\_\_\_  
NO. \_\_\_\_\_