

F. & S. SHE.	SECTION	COUNTY	TOTAL SHEETS	SHEET NO.
2670	03-00095-00-RS	LAKE	67	40
STA.		TO STA.		
FED. ROAD DIST. NO. 7		ILLINOIS		FED. AID PROJECT

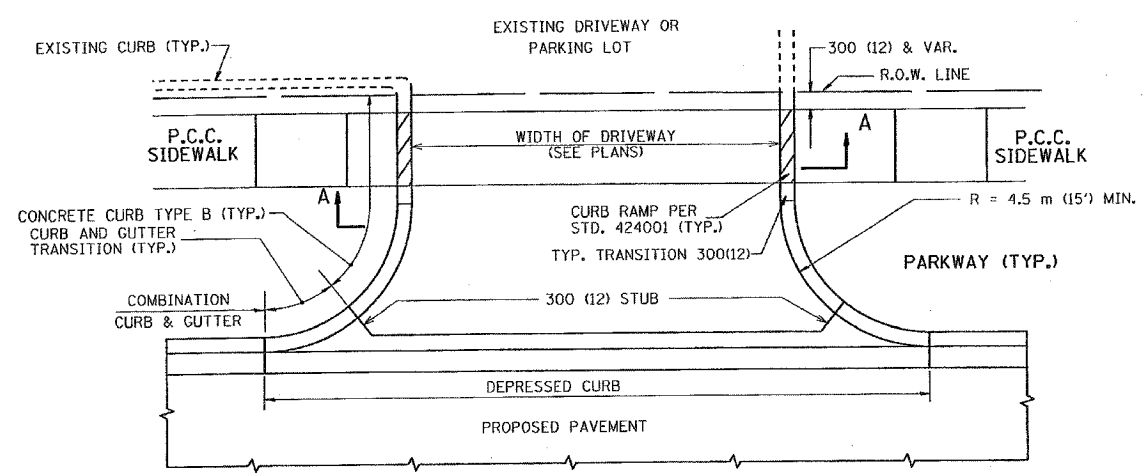

WITH CONCRETE CURB, TYPE B

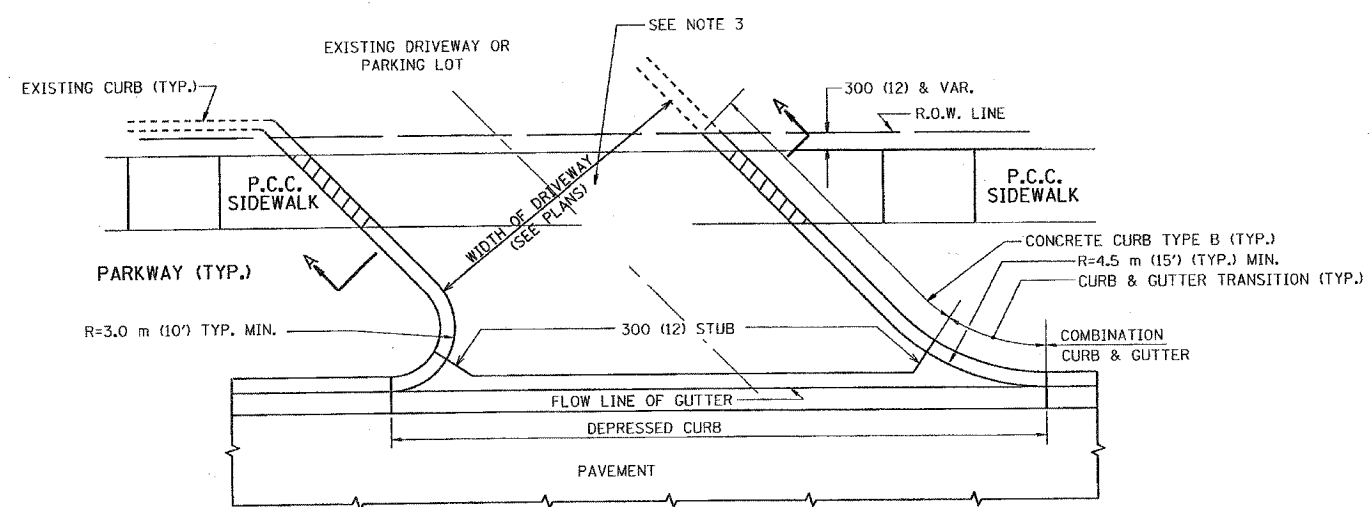

WITH CONCRETE CURB, TYPE B

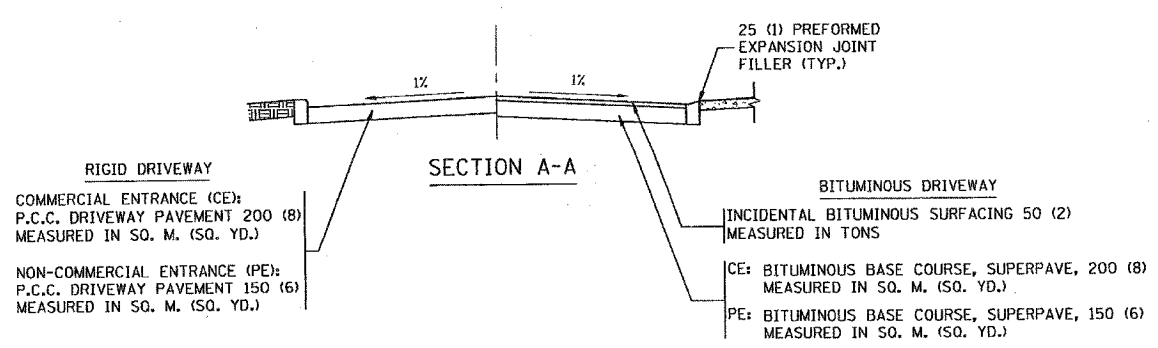

RIGID DRIVEWAY
 COMMERCIAL ENTRANCE (CE):
 P.C.C. DRIVEWAY PAVEMENT 200 (8)
 MEASURED IN SQ. M. (SQ. YD.)
 NON-COMMERCIAL ENTRANCE (PE):
 P.C.C. DRIVEWAY PAVEMENT 150 (6)
 MEASURED IN SQ. M. (SQ. YD.)

BITUMINOUS DRIVEWAY
 INCIDENTAL BITUMINOUS SURFACING 50 (2)
 MEASURED IN TONS
 CE: BITUMINOUS BASE COURSE, SUPERPAVE, 200 (8)
 MEASURED IN SQ. M. (SQ. YD.)
 PE: BITUMINOUS BASE COURSE, SUPERPAVE, 150 (6)
 MEASURED IN SQ. M. (SQ. YD.)

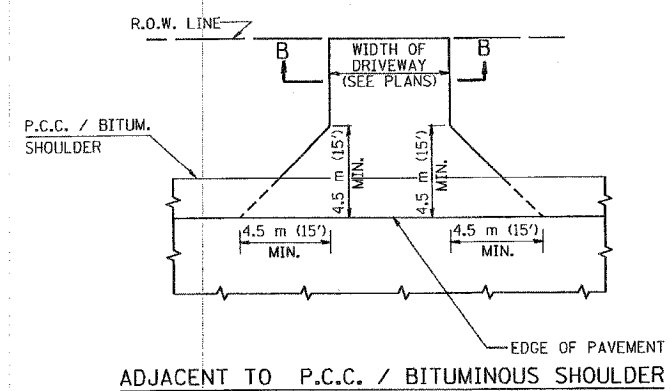

ADJACENT TO P.C.C. / BITUMINOUS SHOULDER

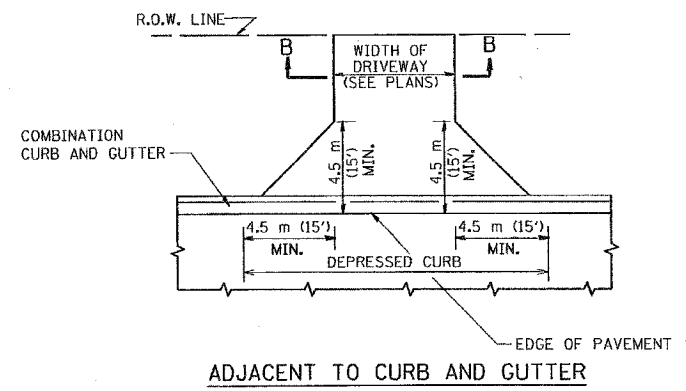

ADJACENT TO CURB AND GUTTER

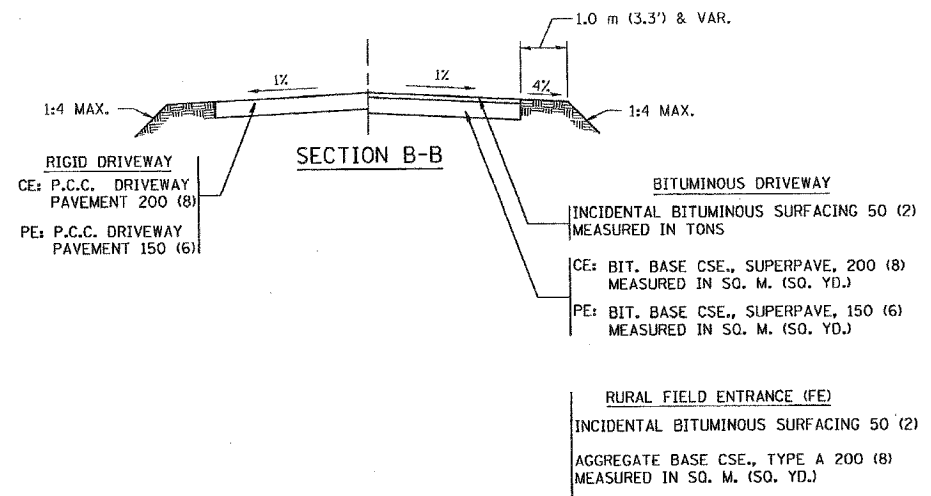

RIGID DRIVEWAY
 CE: P.C.C. DRIVEWAY PAVEMENT 200 (8)
 PE: P.C.C. DRIVEWAY PAVEMENT 150 (6)

BITUMINOUS DRIVEWAY
 INCIDENTAL BITUMINOUS SURFACING 50 (2)
 MEASURED IN TONS
 CE: BIT. BASE CSE., SUPERPAVE, 200 (8)
 MEASURED IN SQ. M. (SQ. YD.)
 PE: BIT. BASE CSE., SUPERPAVE, 150 (6)
 MEASURED IN SQ. M. (SQ. YD.)

RURAL FIELD ENTRANCE (FE)
 INCIDENTAL BITUMINOUS SURFACING 50 (2)
 MEASURED IN TONS
 AGGREGATE BASE CSE., TYPE A 200 (8)
 MEASURED IN SQ. M. (SQ. YD.)

GENERAL NOTES:

DRIVEWAY SLOPES, LOCATIONS, & GEOMETRIC LAYOUT SHALL BE IN ACCORDANCE WITH THE LATEST EDITION OF THE "HANDBOOK FOR POLICY ON PERMITS FOR ACCESS DRIVEWAYS TO STATE HIGHWAYS". FOR FURTHER LAYOUT REQUIREMENTS, REFER TO ILLUSTRATIONS IN THE PERMIT HANDBOOK. DRIVEWAYS SHALL BE REPLACED IN KIND, UNLESS OTHERWISE NOTED ON THE PLANS.

COMMERCIAL DRIVEWAYS SHALL BE CONSTRUCTED WITH CONCRETE CURB, TYPE B RETURNS EXCEPT WHEN THE SIDEWALK EDGE IS 1.2 METERS (4 FEET) OR LESS FROM THE BACK OF CURB, CONSTRUCT A FLARE DRIVEWAY WITHOUT CURB.

THE RESIDENT ENGINEER SHALL CONTACT THE TRAFFIC PERMIT OFFICE AT 847/ 705-4131 FOR ANY QUESTIONS ON DRIVEWAYS SHOWN IN THE PLANS, SPECIFICALLY IN REFERENCE TO ADDITIONAL AND/OR RELOCATION/REMOVAL OF A DRIVEWAY.

COMBINATION CONCRETE CURB & GUTTER SHALL BE MEASURED STRAIGHT ACROSS THE DRIVEWAY. NO ADDITIONAL COMPENSATION WILL BE ALLOWED FOR THE CURB & GUTTER TRANSITION.

25 (1) PREFORMED EXPANSION JOINT FILLER WILL NOT BE PAID SEPARATELY, BUT SHALL BE CONSIDERED INCLUDED IN THE COST OF THE P.C.C. DRIVEWAY PAVEMENT OR P.C.C. SIDEWALK.

WHEN THE P.C.C. SIDEWALK EXTENDS THROUGH THE DRIVEWAY, THE THICKNESS OF THE SIDEWALK IN THE DRIVEWAY AREA SHALL BE THE SAME AS THE DRIVEWAY THICKNESS. SIDEWALK WILL BE PAID FOR AS P.C.C. SIDEWALK OF THE THICKNESS SPECIFIED. SIDEWALK CROSS SLOPE THRU DRIVEWAY AREA TO BE A MAXIMUM OF 1:50.

ALL DIMENSIONS ARE IN MILLIMETERS (INCHES) UNLESS OTHERWISE NOTED

ILLINOIS DEPARTMENT OF TRANSPORTATION

DRIVEWAY DETAILS
 DISTANCE BETWEEN R.O.W. AND FACE OF CURB / EDGE OF SHOULDER >= 4.5 m (15')

REVISIONS	
NAME	DATE
R. SHAH	08-05-95
R. SHAH	11-04-95
J. POLLASTRINI	08-12-96
J. POLLASTRINI	12-14-96
A. ABBAS	03-21-97
T. HOLTZ	04-08-97
M. GOMEZ	04-06-01

SCALE: NONE
 DATE PLOTTED: 12/13/01
 DRAWN BY: SG
 CHECKED BY: JFP