

STATE OF ILLINOIS
DEPARTMENT OF TRANSPORTATION

ROUTE NO.	SECTION	COUNTY	TOWNSHIP	SHEET NO.	SHEET NO. -9 30 - SHEETS CONTRACT 83790
2758	*	LAKE	40	19	
FED. ROAD DIST. NO.	ILLINOIS	FED. AID PROJECT	• 02-00025-00-BR		

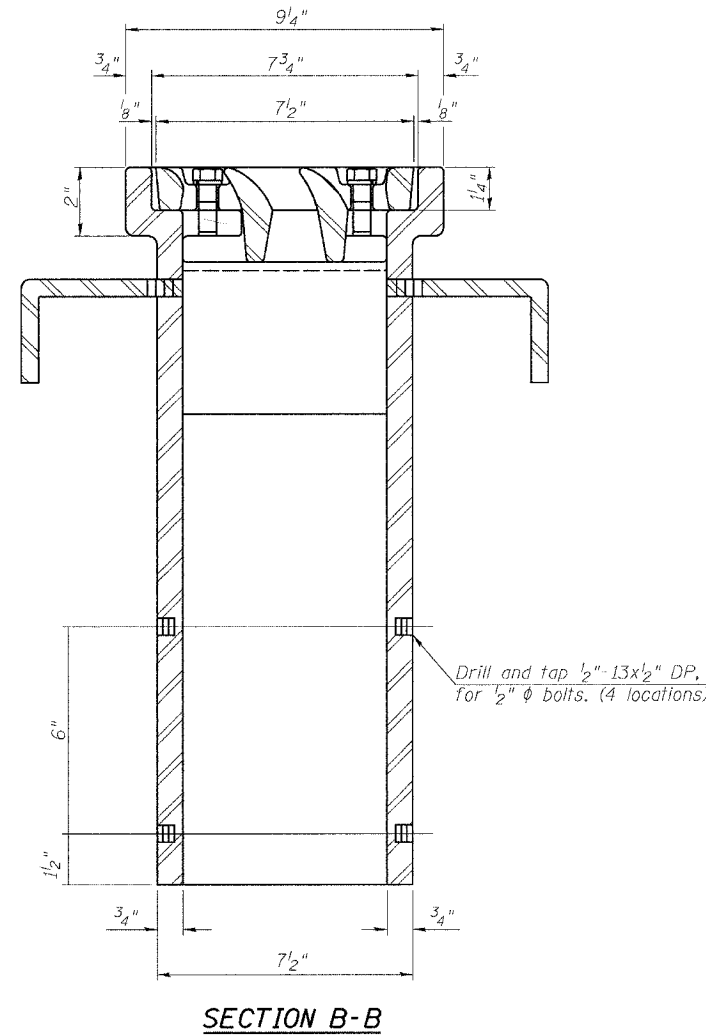
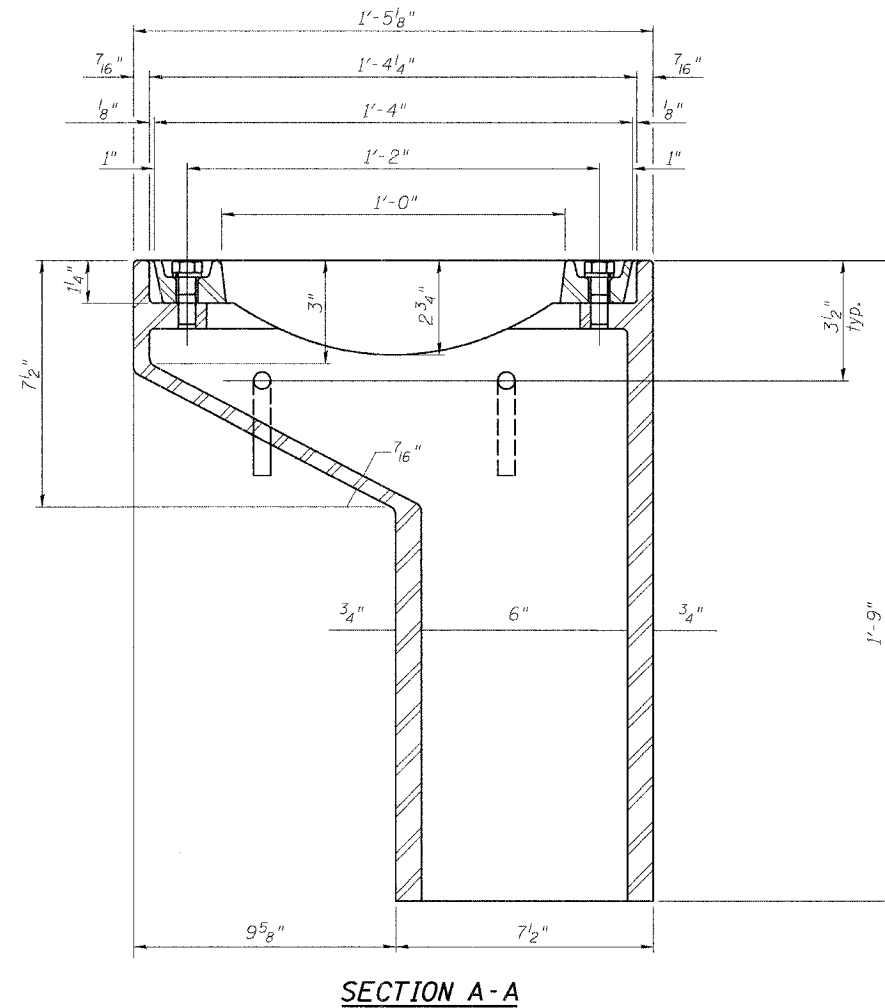
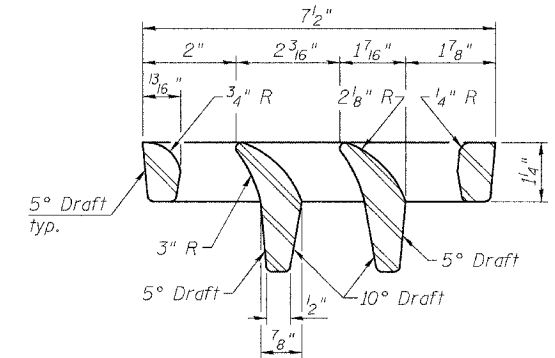
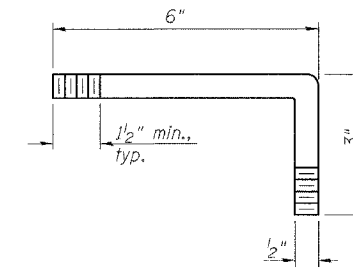
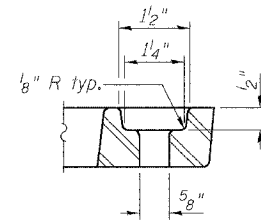
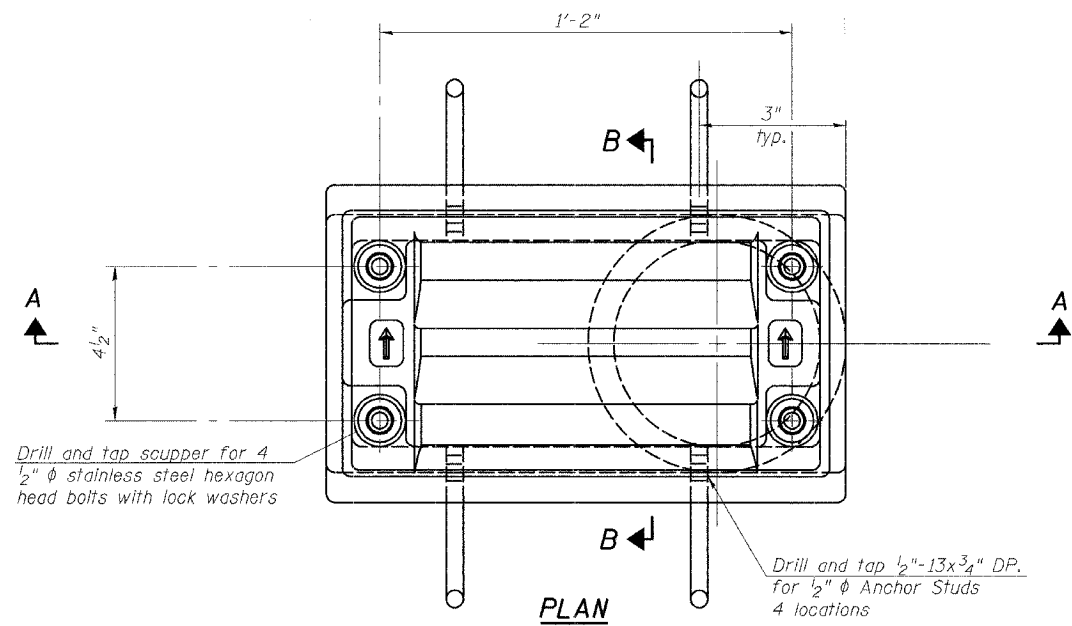

Notes: All cast iron parts shall be gray iron conforming to the requirements of AASHTO M 105, Class 35B.
Bolts, anchor studs, washers and nuts shall conform to the requirements of ASTM A 307 and shall be galvanized according to AASHTO M 232.
The grate, frame and downspout shall be galvanized according to AASHTO M 111 and ASTM A 385. Downspouts located on the exterior side of a painted steel fascia beam shall be painted with the finish coat specified for the exterior side of the fascia beam.
As an alternate, bolts, anchor studs, washers and nuts may be stainless steel according to Article 1006.29(d) of the Standard Specifications.
Structural steel weldments of equal sections and of the same configuration may be substituted for cast iron. Fillet or full penetration welds shall be used for the weldments. Details shall be submitted to the Engineer for approval.
The Contractor shall take appropriate measures to assure that Protective Coat is not applied to the scupper.
Cost of the Grate, Frame, Downspout, Anchor Studs, Bolts, Washers and Nuts including complete installation of the scupper shall be paid for at the contract unit price each for Drainage Scupper, DS-11.

BILL OF MATERIAL

ITEM	UNIT	QUANTITY
Drainage Scupper, DS-11	Each	4

STEEL DRAINAGE SCUPPER

MOFFETT ROAD OVER
DRAINAGE RAVINE
FAU 2758
LAKE COUNTY
S.N. 049-6803

TYLIN INTERNATIONAL

DESIGNED	- SP
CHECKED	- SP
DRAWN	- SP
CHECKED	-

DATE: 02-23-2005