

**EXISTING TYPICAL CROSS SECTION**  
**MAPLE AVENUE**  
**STATION 55+98 TO STATION 80+78**

**LEGEND OF SYMBOLS**

| SYMBOL | DESCRIPTION  |
|--------|--|
| A      | INTERMITTENT COMBINATION CONCRETE CURB & GUTTER, TYPE B-6.18                                 |
| B      | INTERMITTENT PORTLAND CEMENT CONCRETE SIDEWALK, 5"   |
| C      | EXISTING SUB-BASE GRANULAR MATERIAL, 4"  |
| D      | EXISTING BITUMINOUS CONCRETE SURFACE COURSE, 2"  |
| E      | EXISTING BITUMINOUS CONCRETE BINDER COURSE, 2"   |
| F      | EXISTING BITUMINOUS BASE COURSE, 10"   |
| G      | PROPOSED BITUMINOUS SURFACE REMOVAL, 2-1/2"  |
| H      | PROPOSED POLYMERIZED LEVELING BINDER (MACHINE METHOD), SUPERPAVE, IL-4.75, N50, MINIMUM 3/4" |
| I      | PROPOSED BITUMINOUS CONCRETE SURFACE COURSE, SUPERPAVE, MIX D, N50, 1-3/4"                   |

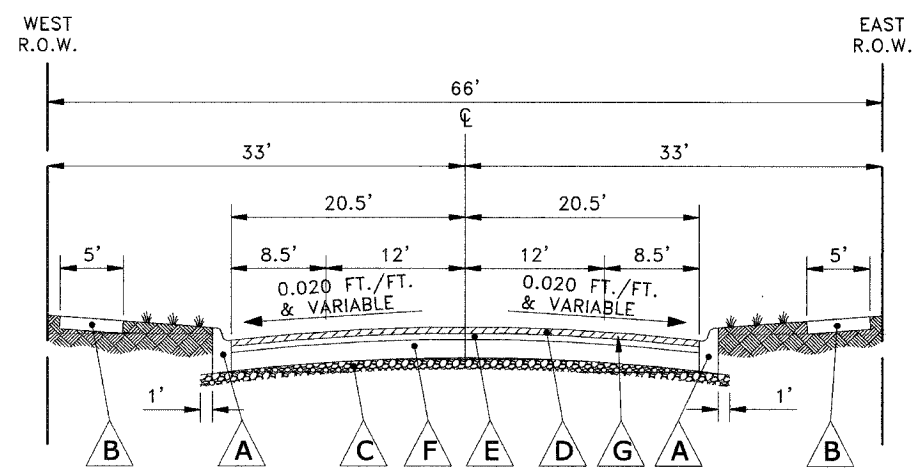

**EXISTING TYPICAL CROSS SECTION**  
**MAPLE AVENUE**  
**STATION 82+87 TO STATION 108+25**