



**GENERAL NOTES**

**STRUCTURAL REMOVAL**

Deck and structural concrete shall be removed as required by Article 501.03 of Standard Specifications (Ref. 2.)

The Contractor shall take care not to damage reinforcement bars and PPC Beams which are to remain in place. Any damage to the reinforcement bars or PPC Beams to remain in place shall be repaired or replaced to the satisfaction of the Engineer at the Contractor's expense.

Tying of loose bars will be required.

Reinforcing bars which have been cut or have lost 25 percent or more of their original cross sectional area shall be supplemented by new in kind reinforcement bars. New bars shall be lapped a minimum of 32 bar diameters to existing bars. An approved "squeeze type" mechanical bar splice capable of developing in tension at least 125 percent of the yield strength of the existing bar shall be used when it is not feasible to provide the minimum bar lap. Alternatively, in kind replacement bars shall be drilled and epoxy grouted into concrete within the closest vicinity of the existing bar to the satisfaction of the Engineer.

Drilling and epoxy grouting of anchor rods, reinforcement bars, and bar splices shall be performed per Article 584 of Standard Specifications (Ref.2).

No welding of bars will be permitted.

Immediately after completion of the concrete removal and reinforcement repairs, the repair areas shall be cleaned of dust and debris. Once the initial cleaning is completed, the repair areas shall be thoroughly blast cleaned to a roughened appearance free from all foreign matter. Particular attention shall be given to removal of concrete fines.

Any method of cleaning which does not consistently produce satisfactory results shall be discontinued and replaced by an acceptable method.

All debris, including water, resulting from the blast cleaning shall be confined and shall be immediately and thoroughly removed from all areas of accumulation. If concrete placement does not follow immediately after the final cleaning, the area shall be carefully protected by a well-anchored polyethylene sheeting.

Exposed reinforcement bars shall be free of dirt, detrimental scale, paint, oil, or other foreign substances which may reduce bond with the concrete. A tight non-scaling coating of rust is not considered objectionable. Loose, scaling rust shall be removed by rubbing with burlap, wire brushing, blast cleaning or other methods approved by the Engineer.

Protective Shielding shall be in place prior to performing any work on the Bridge Superstructure.

Contractor is responsible to obtain Tollway Permitting for all lane closures with regard to installing and removing of the Protective Shield. Cost incidental to Protective Shield.

**BILL OF MATERIAL**

Bar	No.	Size	Length	Shape
d(E)	132	#5	3'-3"	
d <sub>1</sub> (E)	132	#5	2'-8"	
e <sub>2</sub> (E)	12	#4	29'-9"	
e <sub>3</sub> (E)	4	#8	29'-9"	
e <sub>4</sub> (E)	4	#5	29'-9"	
k(E)	120	#5	5'-9"	
w(E)	24	#5	29'-9"	
Reinforcement Bars, Epoxy Coated		Lbs.	2959	
Concrete Superstructure		Cu. Yd.	9.7	
Concrete Structures		Cu. Yd.	16.7	

\*\*\* For Bar Bending Diagrams, See Sheet S-10.

**CONSTRUCTION**

Plan dimensions and details relative to existing structure have been taken from existing plans and are subject to nominal construction variations. It shall be the Contractor's responsibility to verify such dimensions and details in the field and make necessary approved adjustments prior to construction or ordering of materials. Such variations shall not be cause for additional compensation for a change in the scope of the work, however, the Contractor will be paid for the quantity actually furnished at the unit price bid for the work.

All construction joints shall be bonded.

Prior to pouring the new concrete for the deck, all loose rust, loose mill scale and all other loose, potentially detrimental foreign material shall be removed from the top surfaces of diaphragms and beams in contact with new concrete. The cost of this work will included in the pay item covering removal of the existing concrete.

Sliding plate bearing under Beam 2 on South Abutment shall be repositioned as required by the special provision "Bearing Repositioning".

All new structural steel shall be shop painted with an inorganic zinc rich primer per Article 1008.22 of Standard Specifications (Ref. 2.) except where noted.

The existing Aluminum Handrails shall be removed and delivered to the ISTHA Maintenance Yard M-5.

**REINFORCEMENT BARS**

All new reinforcement bars shall conform to the requirements of AASHTO M31 or M322, Grade 60.

Cover from the concrete to face of reinforcement bars shall be 2" unless otherwise shown.

Reinforcement bar bending dimensions are out to out.

Reinforcement bars designated "(E)" shall be epoxy coated.

Reinforcement bar splices shall be in accordance with Bridge Manual (Ref.1).

**REFERENCES**

1. Bridge Manual, Illinois Department of Transportation, 2004.
2. Standard Specifications for Road and Bridge Construction, Illinois Department of Transportation, Adopted January 1, 2002.

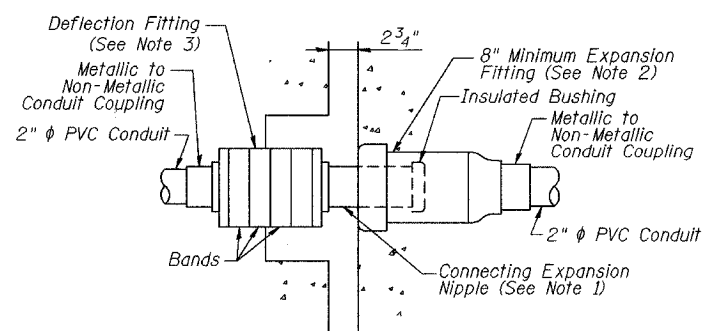

**DETAIL "A"**  
**CONDUIT EXPANSION/DEFLECTION COUPLING**

**STATE OF ILLINOIS**  
**DEPARTMENT OF TRANSPORTATION**

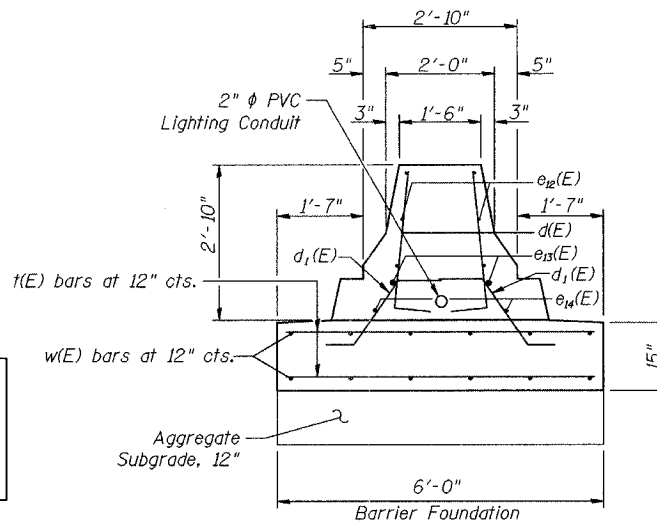

**SECTION A-A**

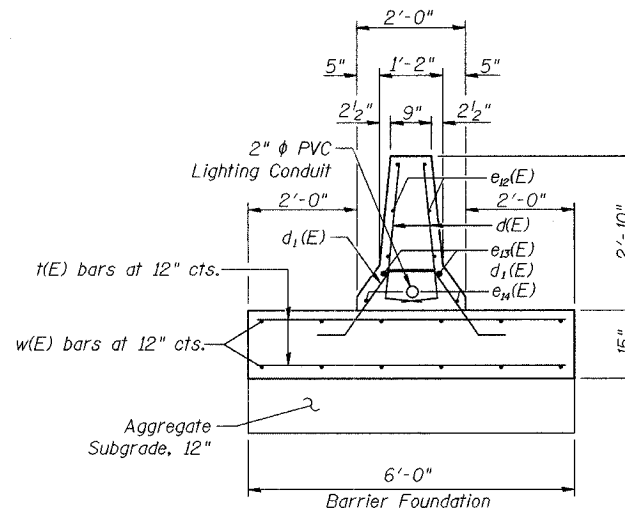

**SECTION B-B**

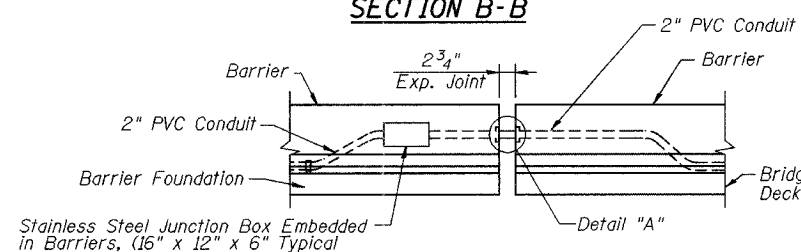

**JUNCTION BOX, EMBEDDED IN BARRIERS**

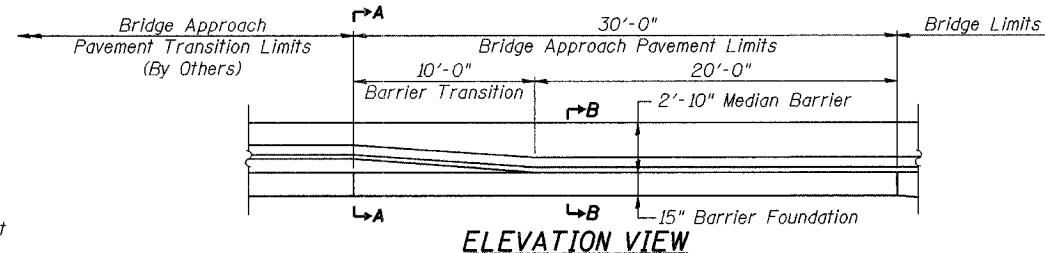

**ELEVATION VIEW**

- Notes For Conduit Expansion/Deflection Coupling:
1. Provide required length of connecting Expansion Nipple. See Sheets S-11 & S-12 for the expansion joint characteristics.
  2. The Barrel of the fitting shall be fully embedded in the concrete of one side of the Expansion Joint.
  3. A cavity opening, if required, shall be 3" larger dia. and a max. depth of half of the Deflection Sleeve length. The Deflection Fitting shall be centered in the opening and embedded in the concrete only up to the Deflection Fitting center.

Concrete Median Removal Added 5-27-05

ROUTE NO.	SECTION	COUNTY	TOTAL SHEETS	SHEET NO.
2585	**	COOK	30	11

SHEET NO. S-2  
OF  
S-21 SHEETS

FEL. ROAD DIST. NO. 1  
ILLINOIS  
FEL. AID PROJECT  
CONTRACT NUMBER 83800

**TOTAL BILL OF MATERIAL**

ITEM	UNIT	SUPER	SUB	TOTAL
Concrete Superstructure	Cu. Yd.	365.0		365.0
Protective Coat	Sq. Yd.	2917	13	2930
Bridge Deck Grooving	Sq. Yd.	1682		1682
Concrete Bridge Deck Scarification, (1/4")	Sq. Yd.	861.3		861.3
Bituminous Concrete Surface Removal	Sq. Yd.	(861)		(861)
Reinforcement Bars, Epoxy Coated	Pound	70870	3940	74810
Bridge Deck Latex Concrete Overlay, (2 1/4")	Sq. Yd.	861.3		861.3
Name Plates	Each	1		1
Concrete Structures	Cu. Yd.		24.0	24.0
Epoxy Crack Sealing	Foot	13		13
Protective Shield	Sq. Yd.	1257		1257
Bar Splicers	Each		152	152
Preformed Joint Seal, 2 1/2"	Foot	170.0		170.0
Bridge Rail Removal	Foot	251		251
Removal Of Existing Concrete Deck	Each	1		1
* Bearing Repositioning	Each		1	1
Form Conc. Rep. < 5"	Sq. Ft.	17.5		17.5
Form Conc. Rep. > 5"	Sq. Ft.		11.4	11.4
Concrete Removal	Cu. Yd.	(53.0)	37.3	(90.3)
Deck Slab Repair (Full Depth), Type II	Sq. Yd.	49		49
Deck Slab Repair (Partial Depth)	Sq. Yd.	151		151
Drainage Scuppers, DS-33	Each		2	2
* Pedestrian Railing Special	Foot	251		251
* Junction Box, Special	Each	4		4
Bridge Approach Pavement	Sq. Yd.	482		482
Temporary Concrete Barrier	Foot	460		460
* Aggregate Subgrade, 12"	Sq. Yd.		40	40
* Approach Slab Removal	Sq. Yd.	413		413
Bituminous Materials (Prime Coat)	Gallon	20		20
Bituminous Concrete Binder Course, Mix. B, Typ. 2	Ton	17		17

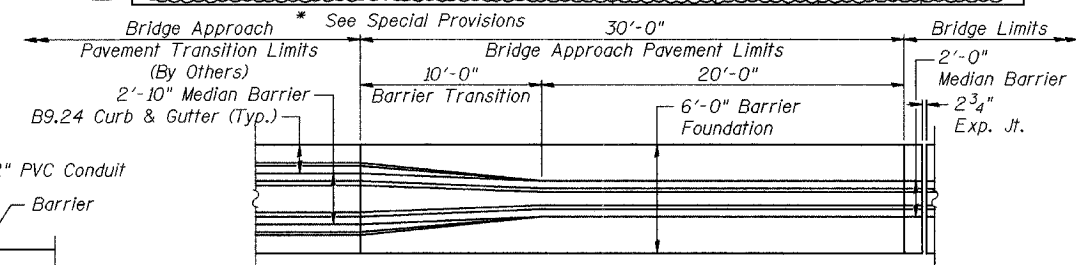

**MEDIAN BARRIER TRANSITION**

STATION 285+04.18  
REBUILT 2005 BY  
VILLAGE OF SCHAUMBURG  
STATE OF ILLINOIS

LOADING HS20  
STR. NO. 016-0676

**NAME PLATE**

See Std. 515001

**GENERAL NOTES AND BILL OF MATERIALS**  
**MEACHAM ROAD OVER NORTHWEST TOLLWAY**  
**F.A.U. ROUTE 2585 SECTION 05-00068-02-BR**  
**COOK COUNTY**

**STA. 285 + 04.18**

**STRUCTURE NO. 016-0676**



DESIGNED: SCHELBIAN/AYARGICOGLU  
DRAWN: SCHELBIAN/AYARGICOGLU  
CHECKED: RALEE

STATE OF ILLINOIS  
DEPARTMENT OF TRANSPORTATION

ROUTE NO.	SECTION	COUNTY	TOTAL SHEETS	SHEET NO.
F.A.U. RTE. 2585	**	COOK	30	12
FED. ROAD DIST. NO. 7		ILLINOIS	FED. AID PROJECT	
** 05-00068-02-BR			CONTRACT NUMBER 83800	

SHEET NO. S-3  
OF  
S-21 SHEETS

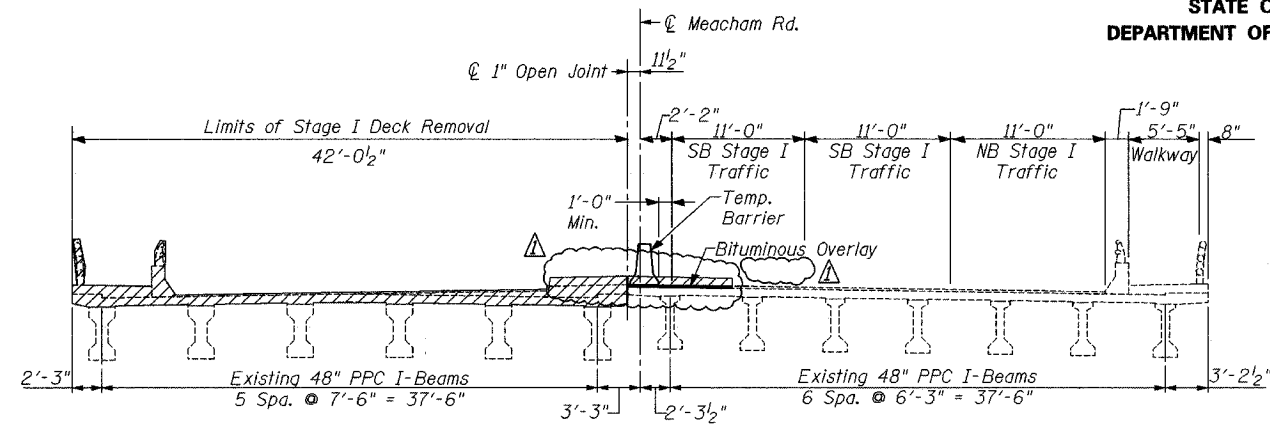

STAGE I REMOVAL

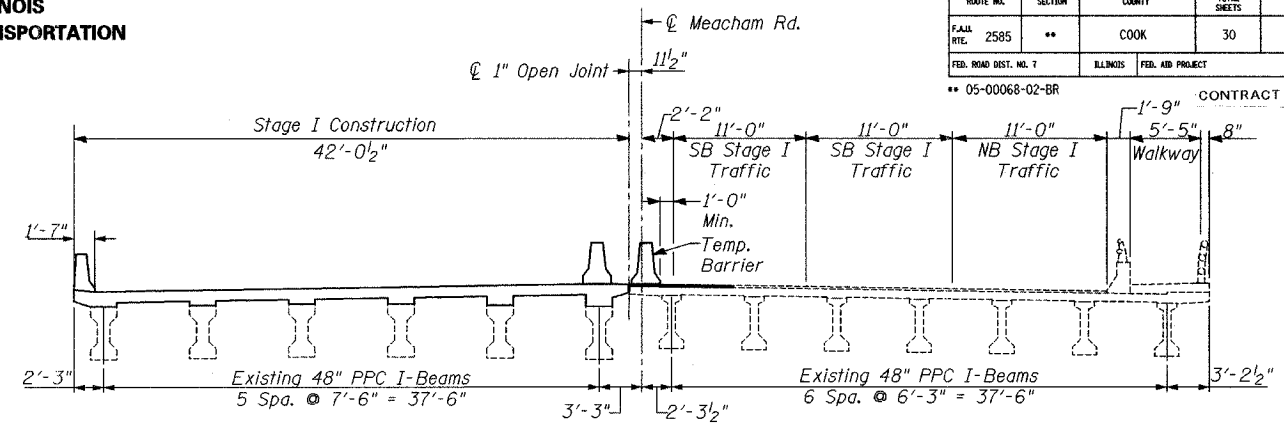

STAGE I CONSTRUCTION

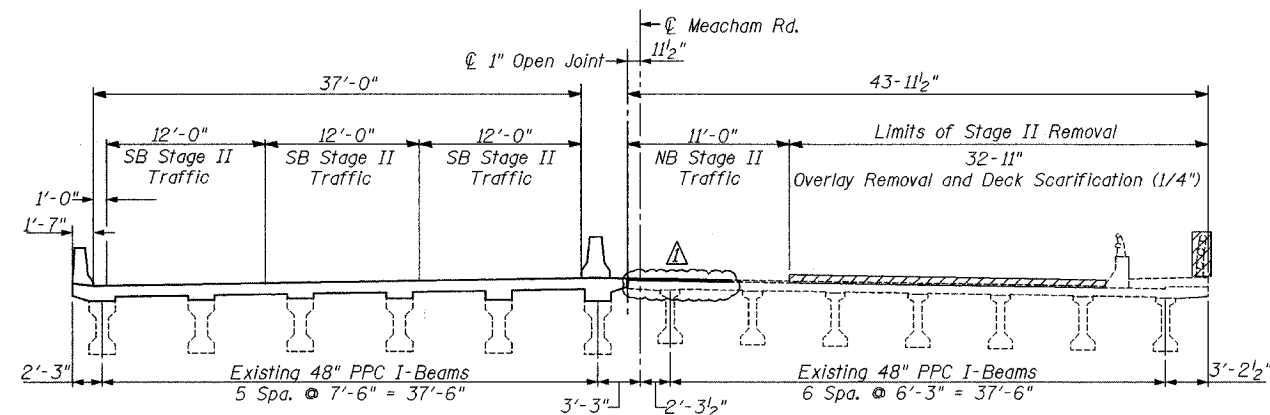

STAGE IIA REMOVAL

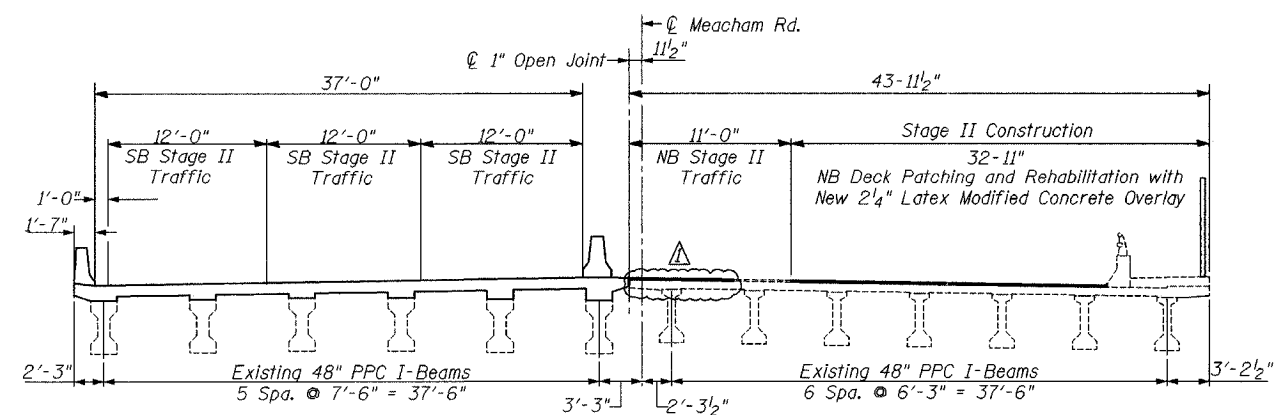

STAGE IIA CONSTRUCTION

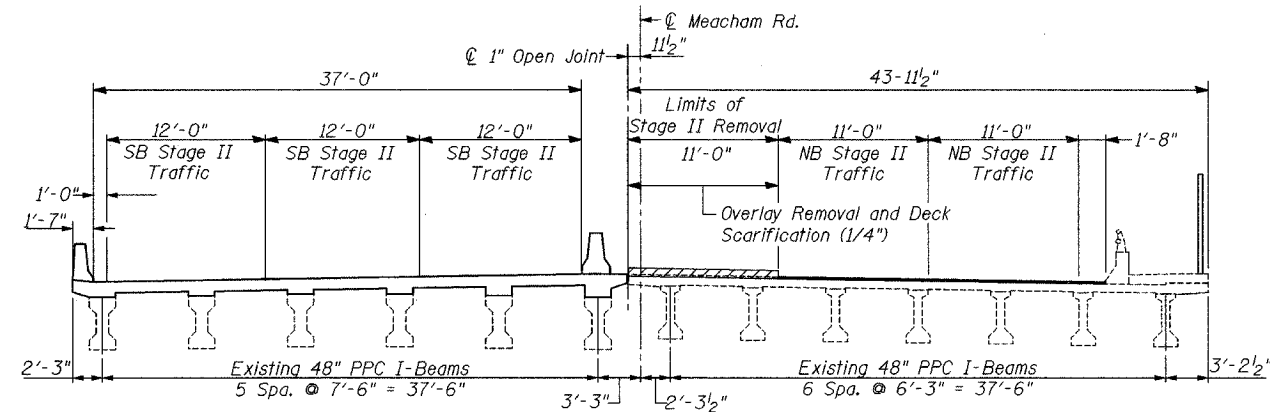

STAGE IIB REMOVAL

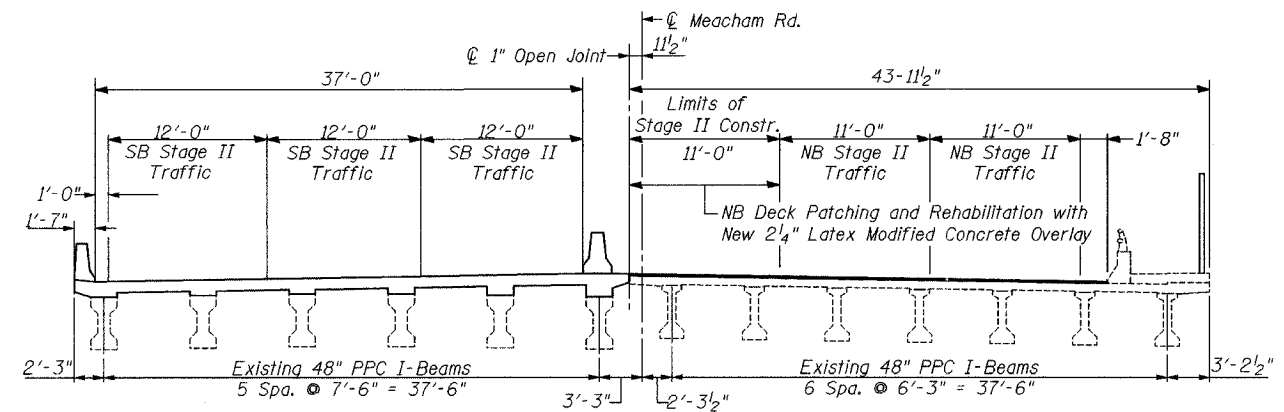

STAGE IIB CONSTRUCTION

LEGEND

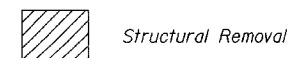

Notes:

- All cross sections are looking North.
- For details of Temporary Concrete Barrier, see Sheet S-22

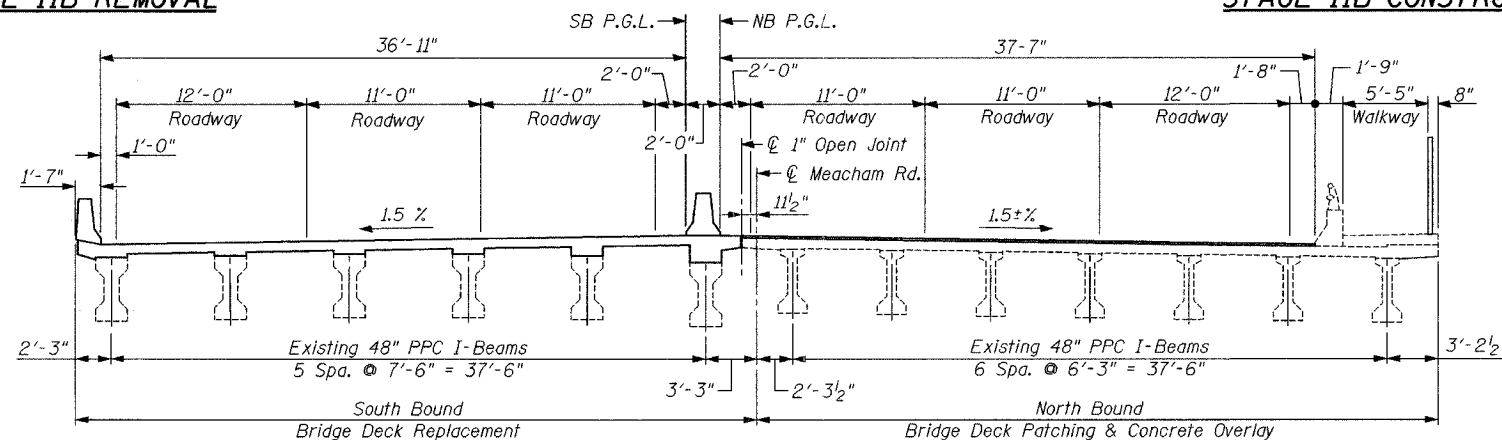

TYPICAL CROSS SECTION

Concrete Median Removal Added 5-27-05

TRAFFIC STAGING AND CONSTRUCTION  
MEACHAM ROAD OVER NORTHWEST TOLLWAY  
F.A.U. ROUTE 2585 SECTION 05-00068-02-BR  
COOK COUNTY  
STA. 285 + 04.18

STRUCTURE NO. 016-0676



DESIGNED: SCHELBIAN/AYARGICOGU  
DRAWN: SCHELBIAN/AYARGICOGU  
CHECKED: RLEE

STATE OF ILLINOIS  
DEPARTMENT OF TRANSPORTATION

ROUTE NO.	SECTION	COUNTY	TOTAL SHEETS	SHEET NO.
FAH RTE. 2585	**	COOK	30	13
FED. ROAD DIST. NO. 7		ILLINOIS	FED. AID PROJECT	
** 05-00068-02-BR		CONTRACT NUMBER 03800		

SHEET NO. S-4  
OF  
S-21 SHEETS

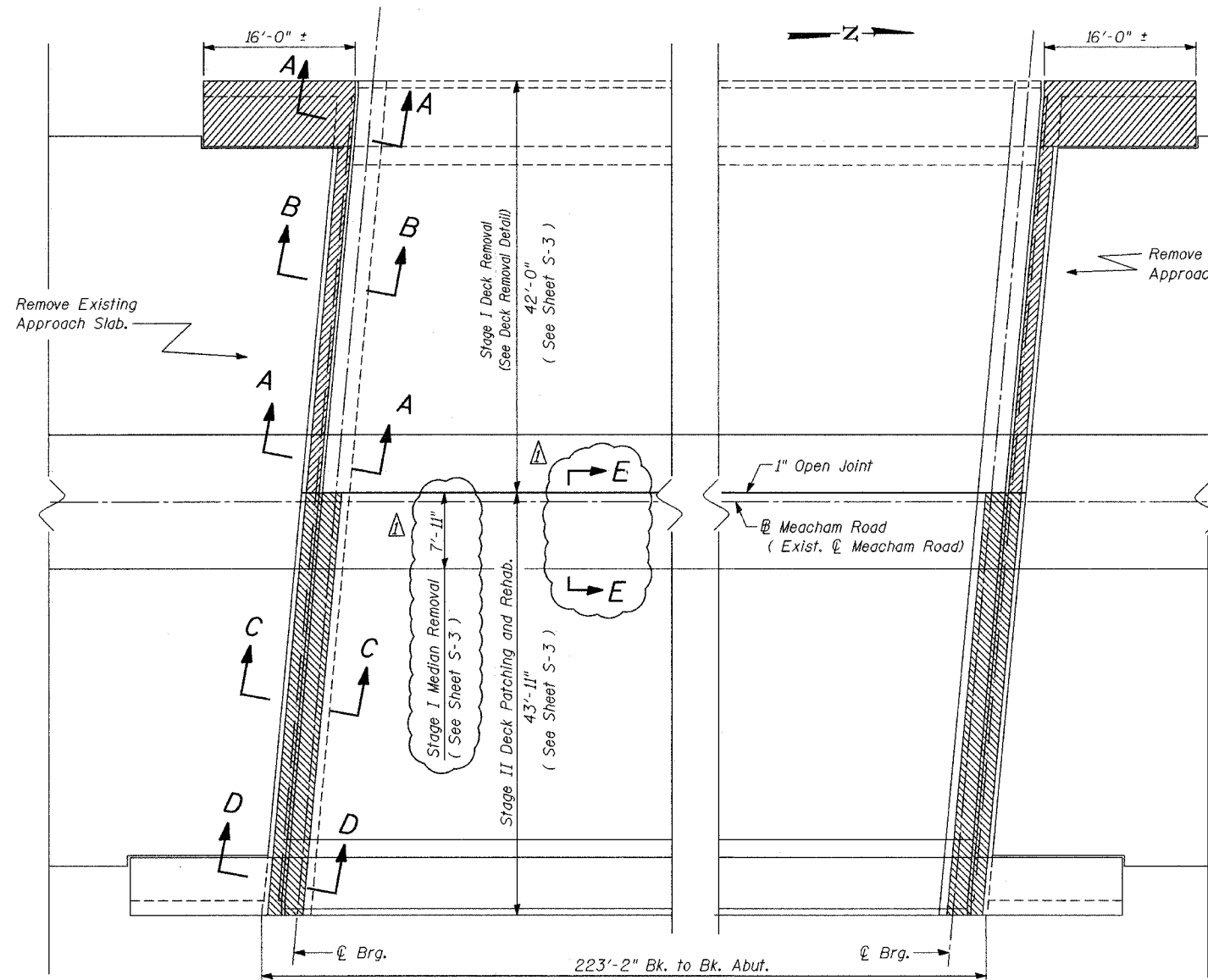

PLAN

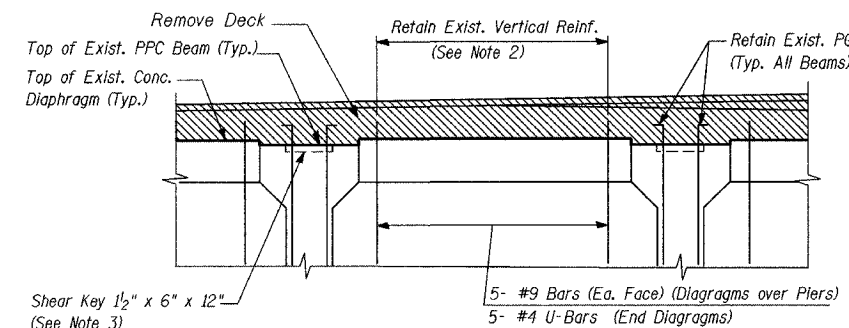
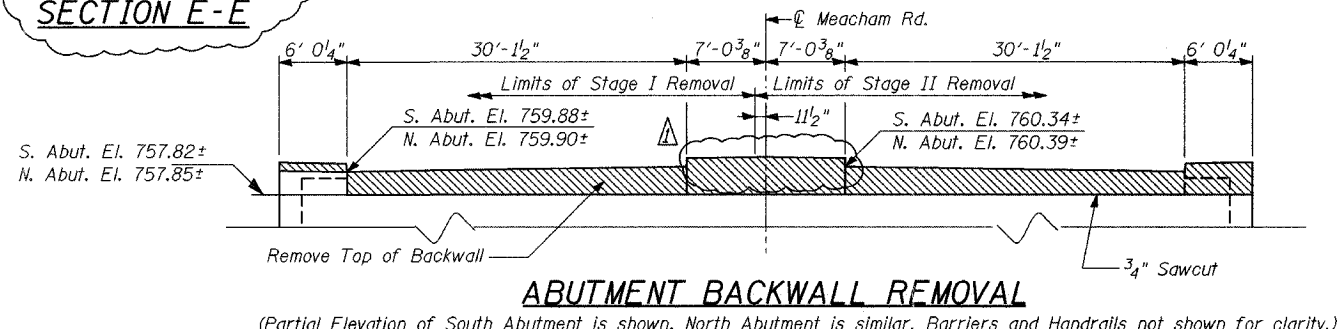
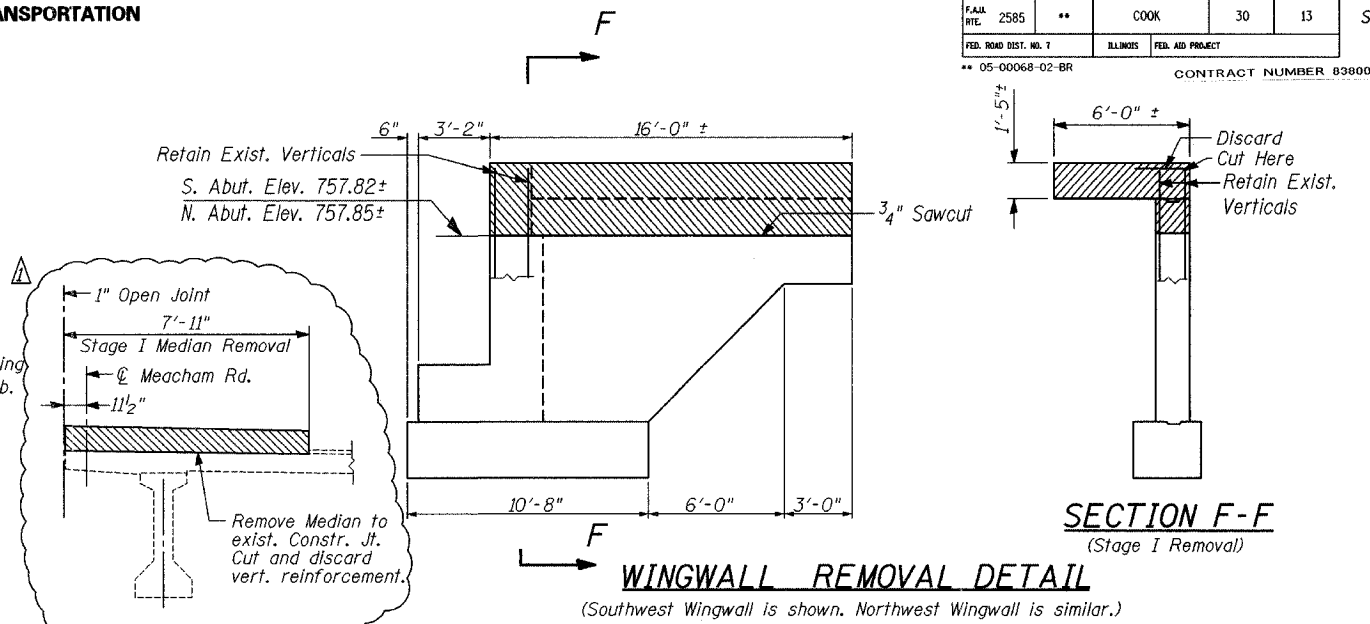

BILL OF MATERIAL

ITEM	UNIT	TOTAL
Concrete Removal	Cu. Yd.	(90.3)
Removal of Existing Concrete Deck	Each	1

Notes:

- Cost of Removal of Reinforcement Bars and Expansion Device shall be included in CONCRETE REMOVAL.
- Existing reinforcement shall be sandblasted clean and incorporated into new construction. Cost shall be included in CONCRETE SUPERSTRUCTURES on Sht. S-16.
- All concrete and debris shall be removed from shear keys on top flanges of all beams. For details of existing beams, see Sht. S-14.

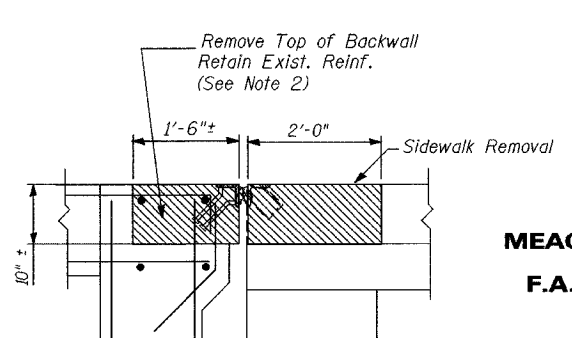
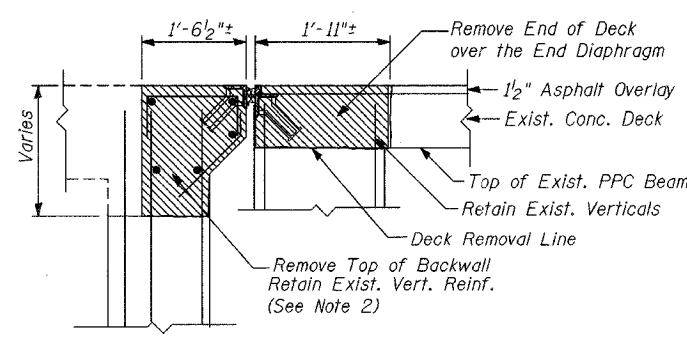
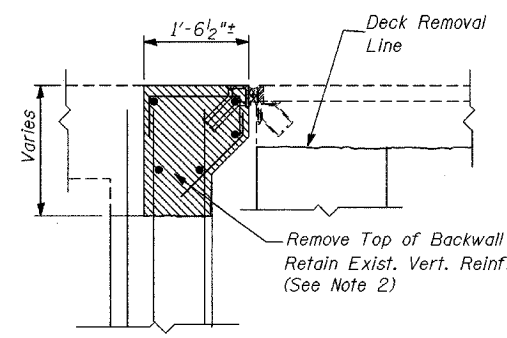
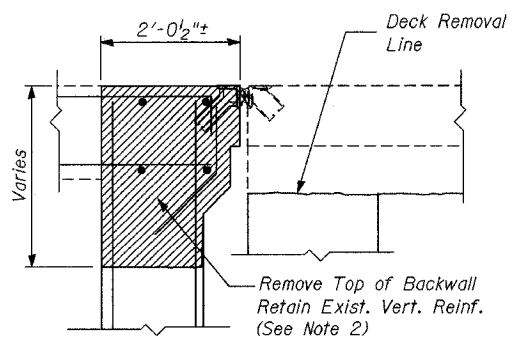

STRUCTURAL REMOVAL  
MEACHAM ROAD OVER NORTHWEST TOLLWAY  
F.A.U. ROUTE 2585 SECTION 05-00068-02-BR  
COOK COUNTY

STA. 285 + 04.18  
STRUCTURE NO. 016-0676

Concrete Median Removal Added 5-27-05

DESIGNED: SCHELBIAN/AYARGICOGU  
DRAWN: SCHELBIAN/AYARGICOGU  
CHECKED: RLEE