

F.A.P. RTE.	SECTION	COUNTY	TOTAL SHEETS	SHEET NO.
750	(112,113) Y, WRS	FAYETTE	159	34
STA.	TO STA.			
FED. ROAD DIST. NO. 7 ILLINOIS FED. AID PROJECT				

CONTRACT NO. 94927

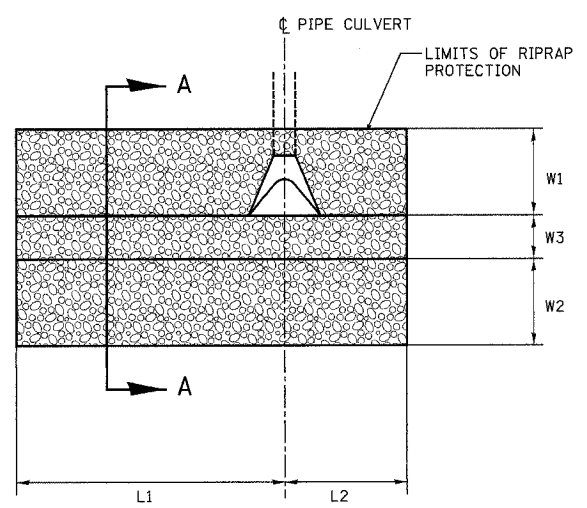

PIPE CULVERT END SECTION
EROSION CONTROL TREATMENT
DETAIL 1

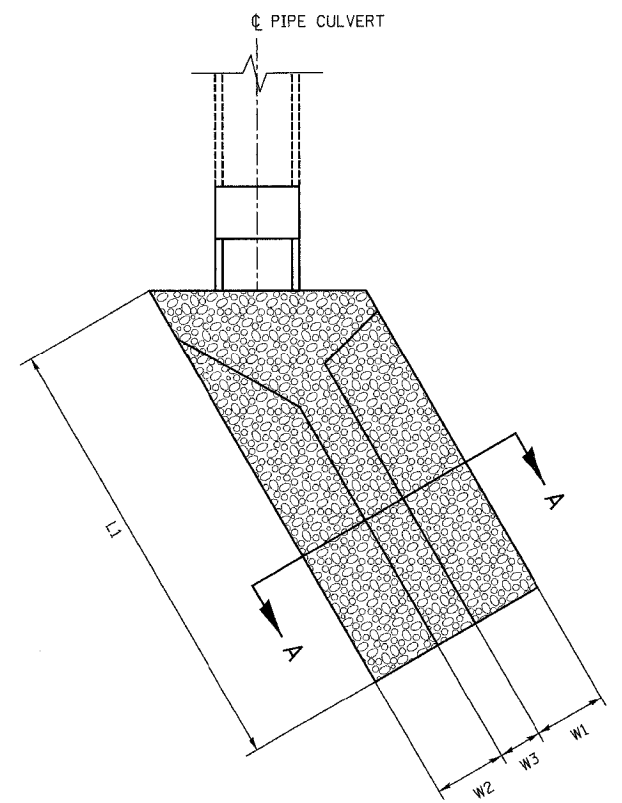

SINGLE BOX CULVERT END SECTION
EROSION CONTROL TREATMENT
DETAIL 2

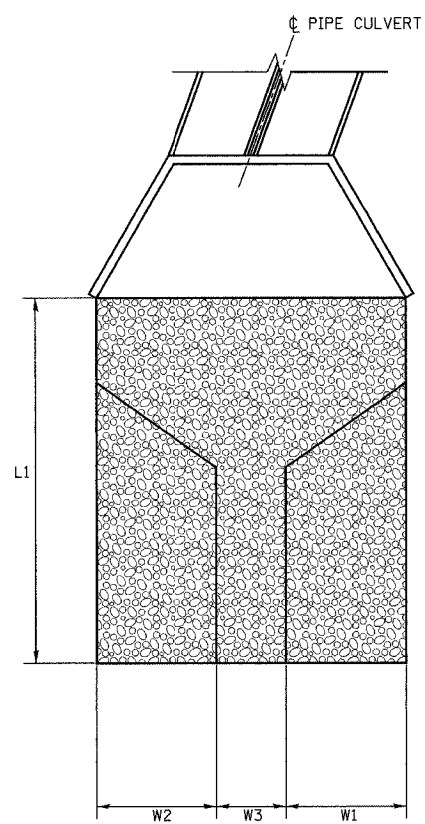

OUTLET LINING
EROSION CONTROL TREATMENT
DETAIL 3

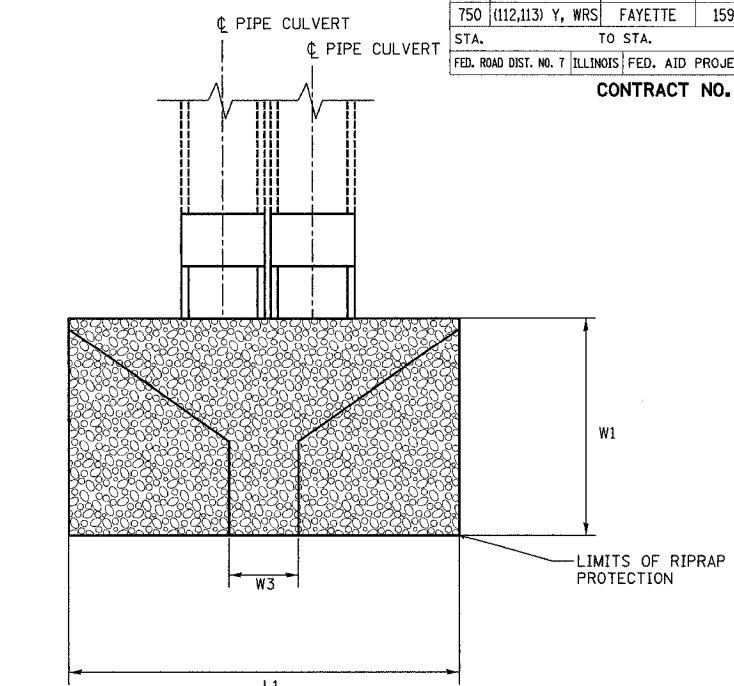

DOUBLE BOX CULVERT END SECTION
EROSION CONTROL TREATMENT
DETAIL 4

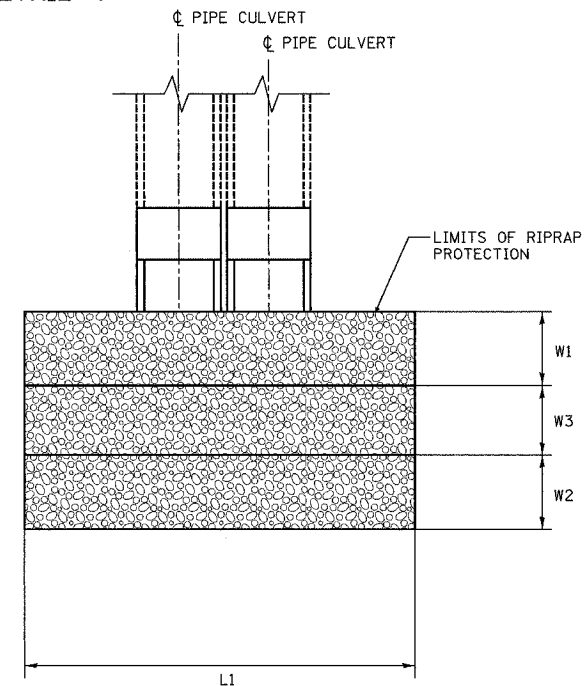

SINGLE AND DOUBLE BOX CULVERT END SECTION
EROSION CONTROL TREATMENT
DETAIL 6

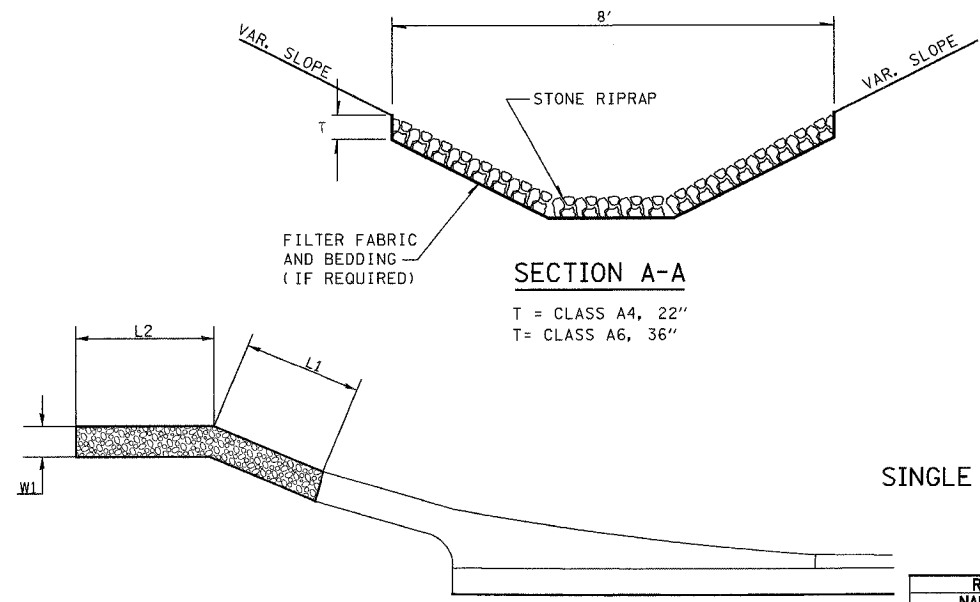

GUTTER OUTLET LINING
EROSION CONTROL TREATMENT
DETAIL 5

RIRAP SQ. YD.													
STRUCTURE NO.	STATION	TO	STATION	SIDE	STONE RIPRAP CLASS A4 SQ. YD.	STONE RIPRAP CLASS A6 SQ. YD.	FILTER FABRIC FOR USE W/ RIPRAP SQ. YD.	W1 FOOT	W2 FOOT	W3 FOOT	L1 FOOT	L2 FOOT	DESCRIPTION
9	212+77.00		212+85.00	LT.	9		9	3	3	2	10		DETAIL 2
10	237+84.10		238+11.65	RT.	16		16	3	3	2	32.6		DETAIL 2
11	256+49.52		256+46.20	RT.	26		26	3	3	2	30		DETAIL 2
	283+11.00		284+50.00	RT.	61		61	2			91		DETAIL 5
	283+50.00		285+98.00	LT.	107		107	2			149		DETAIL 5
12	299+20.86		299+14.97	LT.		19	19	8		2	24		DETAIL 3
13	314+34.02		314+29.39	RT.	24		24	3	3	2	28		DETAIL 2
14	324+64.61		324+55.85	LT.	32		32	3	3	2	37		DETAIL 2
15	326+23.86		325+92.90	LT.	27		27	3	3	2	41		DETAIL 3
16	356+53.21		356+56.67	RT.	8		8	3	3	2	10		DETAIL 2
17	369+62.08		369+80.19	RT.	16		16	3	3	2	18		DETAIL 6
18	388+29.63		388+43.02	RT.	32		32	3	3	2	36		DETAIL 2
	389+50.00		390+46.00	RT.	46		46	4			46	58	DETAIL 5
	390+50.00		391+46.00	LT.	44		44	4			46	52	DETAIL 5
	400+69.21		401+07.44	RT.	27		27	4			37	7	DETAIL 5
19	401+28.50		401+28.30	RT.	34		34	6	6	2	18		DETAIL 2
20	*OMITTED*		*OMITTED*										
21	418+59.36		418+56.73	LT.	16		16	13		2	12		DETAIL 3
22	424+10.34		424+16.19	LT.	11		11	3	3	2	13		DETAIL 2
23	427+95.32		428+01.71	LT.	19		19	12		2	30		DETAIL 3
24	428+22.11		428+08.92	LT.	11		11	3	3	2	12		DETAIL 2
25	429+80.92		429+72.68	LT.	20		20	11		2	25		DETAIL 3
TOTALS					586	19	606						

REVISIONS	
NAME	DATE
KdG	3/02/05

ILLINOIS DEPARTMENT OF TRANSPORTATION
RIPRAP DETAILS
F.A.P. 750 (IL. RTE. 185)
SECTION 112,113 - FAYETTE CO.
SCALE: DATE JANUARY 19, 2005
DRAWN BY CRO
CHECKED BY RCY

DATE
BY
SURVEYED
ALIGNED
CHECKED
NOTE BOOK
NO. FILE NAME

DATE
BY
SURVEYED
ALIGNED
CHECKED
NOTE BOOK
NO. FILE NAME

J:\2003\030045\0002\civil\phase 2\kdg\vgdgn\vp2_750_detail_sheets.dgn 12:54:09 PM 3/2/2005