

DATE	
BY	
FINAL SURVEY PLOTTED	
NOTE BOOK TEMPLATE	
AREAS CHECKED	
NO.	

DATE	
BY	
ORIGINAL SURVEY PLOTTED	
NOTE BOOK TEMPLATE	
AREAS CHECKED	
NO.	

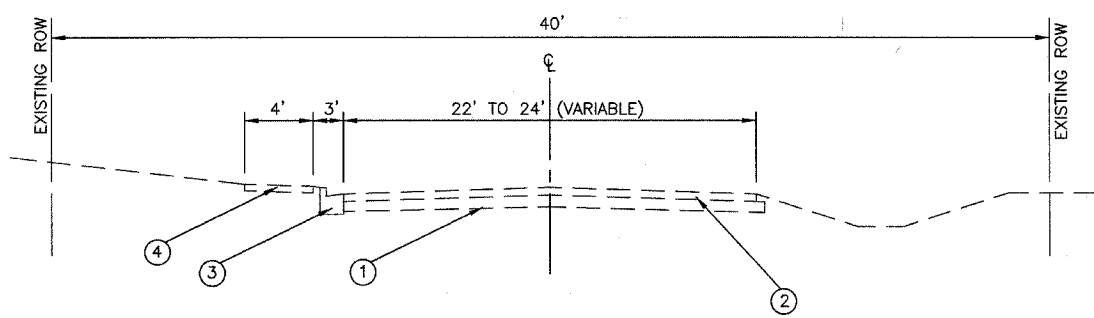

**EXISTING TYPICAL SECTION**

STA. 93+64 TO 95+15  
(NOT TO SCALE)

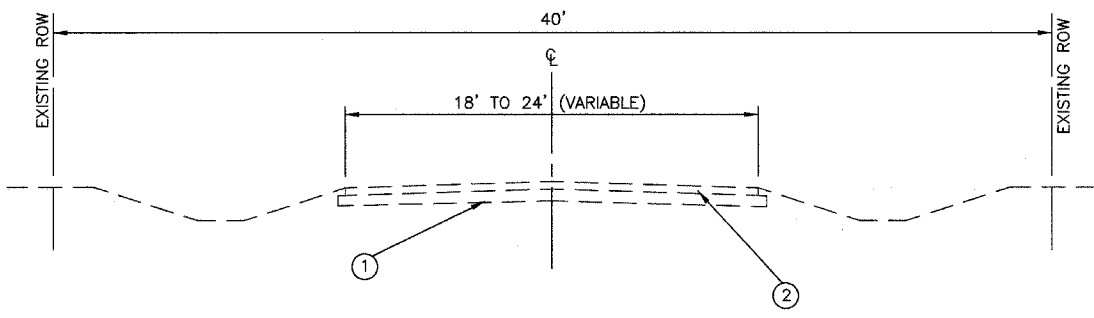

**EXISTING TYPICAL SECTION**

STA. 88+50.61 TO STA. 93+64  
STA. 95+15 TO STA. 97+30  
(NOT TO SCALE)

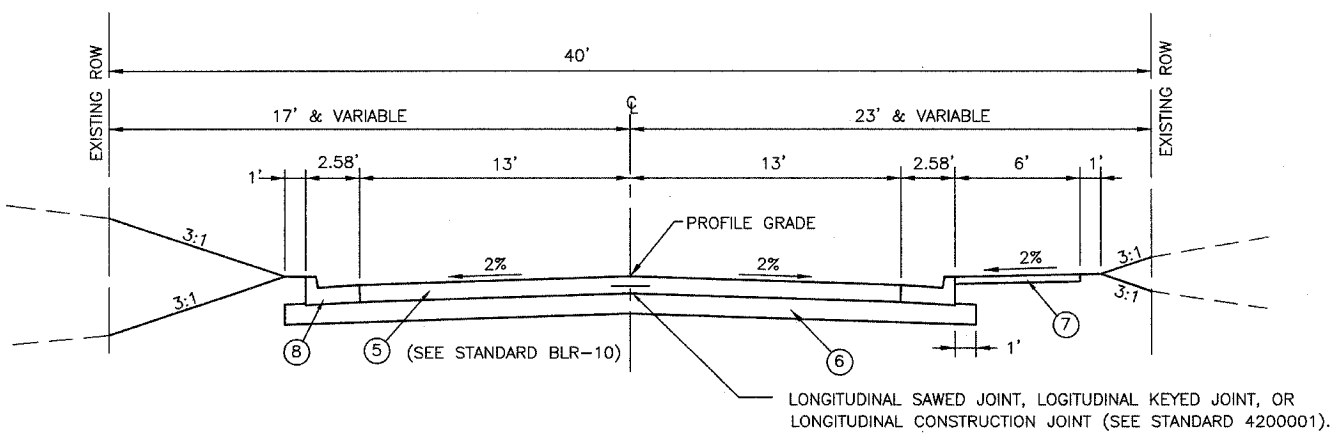

**PROPOSED TYPICAL SECTION**

STA. 88+50.61 TO STA. 97+30.00  
(NOT TO SCALE)

NOTE:  
SEE CROSS SECTIONS FOR VARIABLE EARTH SLOPES. SEE PLAN AND PROFILE SHEETS FOR VARIABLE PROPOSED R.O.W. WIDTHS

**LEGEND**

- ① EXISTING AGGREGATE BASE COURSE
- ② EXISTING BITUMINOUS SURFACE TREATMENT
- ③ EXISTING CURB & GUTTER
- ④ EXISTING CONCRETE SIDEWALK
- ⑤ PROPOSED PORTLAND CEMENT CONCRETE PAVEMENT, 7"
- ⑥ PROPOSED MODIFIED SOILS, 12"
- ⑦ PROPOSED PORTLAND CEMENT CONCRETE SIDEWALK, 4"
- ⑧ COMBINATION CONCRETE CURB AND GUTTER, TYPE B-6.24 (TYP)

**MIXTURE REQUIREMENTS SUPERPAVE PROJECT**

20 YR ESAL'S	
MIXTURE USE	INCIDENTAL BIT SURF SUPER
AC/PG	PG 64-22
RAP% (MAX)	15%
DESIGN AIR VOIDS	4.0% @ NDES=50
MIX COMPOSITION (GRADATION MIXTURE)	
FRICITION AGG	MIXTURE C

**STRUCTURAL DESIGN DATA**

STRUCTURAL DESIGN TRAFFIC: Year 2024

PV = 97% SU = 2% MU = 1%

ROAD/STREET CLASSIFICATION: Class II

PERCENTAGE OF STRUCTURAL DESIGN TRAFFIC IN DESIGN LANE:

P = 50% S = 50% M = 50%

TRAFFIC FACTOR: Actual TF = 0.19  
Minimum TF = 0.5

SUBGRADE SUPPORT RATING

SSR = Poor

THEREFORE USE: SINCE QUANTITY < 3,000 S.Y., MATCH EXISTING PAVEMENT SECTIONS.  
7" NON-REINFORCED P.C.C. PAVEMENT WITH 12.5' MAX. TRANSVERSE JOINT SPACING

**SUMMARY OF QUANTITIES**

CODE NO.	ITEM	UNIT	TOTAL QUANTITIES
20100110	TREE REMOVAL (6 TO 15 UNITS DIAMETER)	UNIT	29
20100210	TREE REMOVAL (OVER 15 UNITS DIAMETER)	UNIT	22
20200100	EARTH EXCAVATION	CU YD	1,372
20800150	TRENCH BACKFILL	CU YD	364
25000115	SEEDING, CLASS 1B	ACRE	0.15
25000400	NITROGEN FERTILIZER NUTRIENT	POUND	15
25000500	PHOSPHORUS FERTILIZER NUTRIENT	POUND	15
25000600	POTASSIUM FERTILIZER NUTRIENT	POUND	15
25100115	MULCH, METHOD 2	ACRE	0.57
28000250	TEMPORARY EROSION CONTROL SEEDING	POUND	42
28000300	TEMPORARY DITCH CHECKS	EACH	2
28000500	INLET AND PIPE PROTECTION	EACH	14
28100105	STONE RIPRAP, CLASS A3	SQ YD	7
28200200	FILTER FABRIC	SQ YD	7
30200650	PROCESSING MODIFIED SOILS 12"	SQ YD	3,915
30201500	LIME	TON	76
35100500	AGGREGATE BASE COURSE, TYPE A 6"	SQ YD	202
35100700	AGGREGATE BASE COURSE, TYPE A 8"	SQ YD	225
40200500	AGGREGATE SURFACE COURSE, TYPE A 6"	SQ YD	84
42000200	PORTLAND CEMENT CONCRETE PAVEMENT 7"	SQ YD	2,959
42001300	PROTECTIVE COAT	SQ YD	3,525
42300200	PORTLAND CEMENT CONCRETE DRIVEWAY PAVEMENT, 6 INCH	SQ YD	186
42400100	PORTLAND CEMENT CONCRETE SIDEWALK 4 INCH	SQ FT	3,826
42400300	PORTLAND CEMENT CONCRETE SIDEWALK 6 INCH	SQ FT	479
44000100	PAVEMENT REMOVAL	SQ YD	212
44000200	DRIVEWAY PAVEMENT REMOVAL	SQ YD	411
44000500	COMBINATION CURB AND GUTTER REMOVAL	FOOT	407
44000600	SIDEWALK REMOVAL	SQ FT	1,552
54213683	PRECAST REINFORCED CONCRETE FLARED END SECTIONS 18"	EACH	1
550A0050	STORM SEWERS, CLASS A, TYPE 1 12"	FOOT	35
550A0090	STORM SEWERS, CLASS A, TYPE 1 18"	FOOT	183
550A0340	STORM SEWERS, CLASS A, TYPE 2 12"	FOOT	408
550A0360	STORM SEWERS, CLASS A, TYPE 2 15"	FOOT	89
550A0380	STORM SEWERS, CLASS A, TYPE 2 18"	FOOT	66
55100300	STORM SEWER REMOVAL 8"	FOOT	140
55100400	STORM SEWER REMOVAL 10"	FOOT	163
56300100	ADJUSTING SANITARY SEWERS, 8-INCH DIAMETER OR LESS	FOOT	50
60100905	PIPE DRAINS 4"	FOOT	100
60100915	PIPE DRAINS 6"	FOOT	100
60219540	MANHOLES, TYPE A, 4'-DIAMETER, TYPE 24 FRAME AND GRATE	EACH	3
60237470	INLETS, TYPE A, TYPE 24 FRAME AND GRATE	EACH	7
60240328	INLETS, TYPE B, TYPE 24 FRAME AND GRATE	EACH	4
60255500	MANHOLES TO BE ADJUSTED	EACH	4
60260400	INLETS TO BE ADJUSTED WITH NEW TYPE 1 FRAME, CLOSED LID	EACH	1
60500060	REMOVING INLETS	EACH	4
60605000	COMBINATION CONCRETE CURB AND GUTTER, TYPE B-6.24	FOOT	1,974
61140200	STORM SEWERS, SPECIAL 12"	FOOT	50
66410400	CHAIN LINK FENCE TO BE REMOVED AND RE-ERECTED	FOOT	131
70101700	TRAFFIC CONTROL AND PROTECTION	L SUM	1
78001110	PAINT PAVEMENT MARKING - LINE 4"	FOOT	509
78001130	PAINT PAVEMENT MARKING - LINE 6"	FOOT	145
78001150	PAINT PAVEMENT MARKING - LINE 12"	FOOT	25
XX004949	INCIDENTAL BITUMINOUS SURFACING, SUPERPAVE	TON	73
Z0000990	AGGREGATE FOR TEMPORARY ACCESS	TON	100
Z0012450	CONCRETE STEPS	CU YD	1.0
Z0022800	FENCE REMOVAL	FOOT	23

\* DENOTES SPECIALTY ITEMS