

** Cost of Timber Block Posts is included with Erecting Structural Steel.

STATE OF ILLINOIS
DEPARTMENT OF TRANSPORTATION

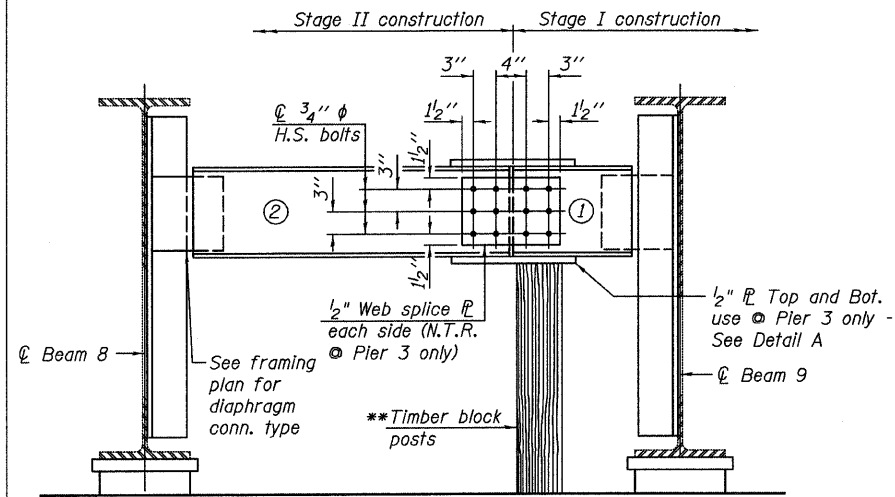

END DIAPHRAGM (D6)

END DIAPHRAGM STAGE
CONSTRUCTION SEQUENCE

- 1.) Order diaphragm in two sections.
- 2.) Attach section ① of diaphragm to beam 9
- 3.) Place timber block posts between section ① of diaphragm and abutment bearing section.
- 4.) Attach section ② of diaphragm to both beam 8 and section ① of diaphragm during stage II construction with splice plates.
- 5.) Remove timber block posts.

Note:
Load carrying components designated "NTR"
shall conform to the Supplemental Requirements
for Notch Toughness, Zone 2.

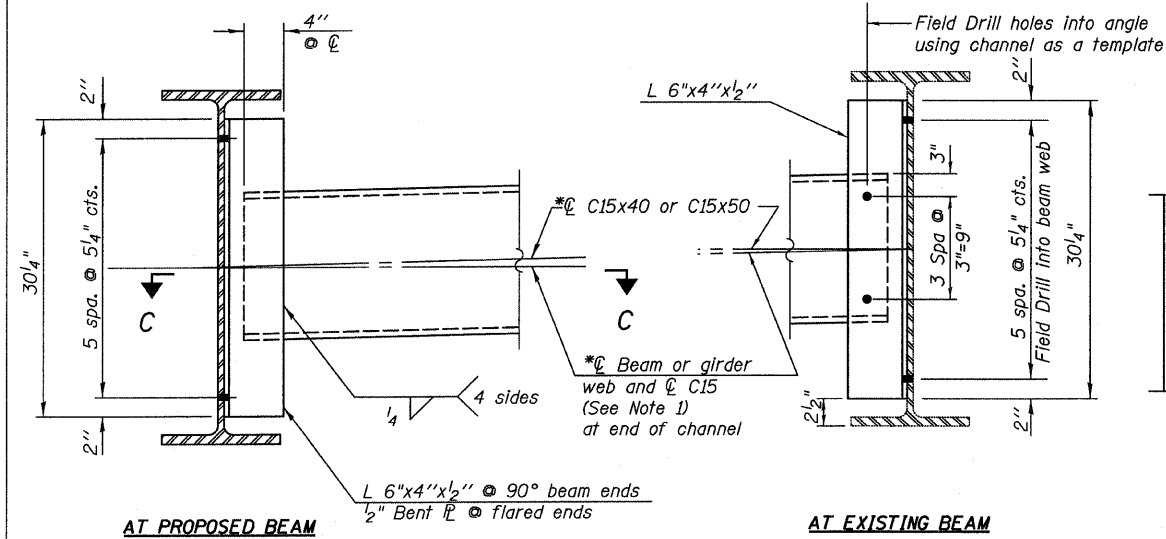

INTERIOR DIAPHRAGMS (D2 THRU D4)

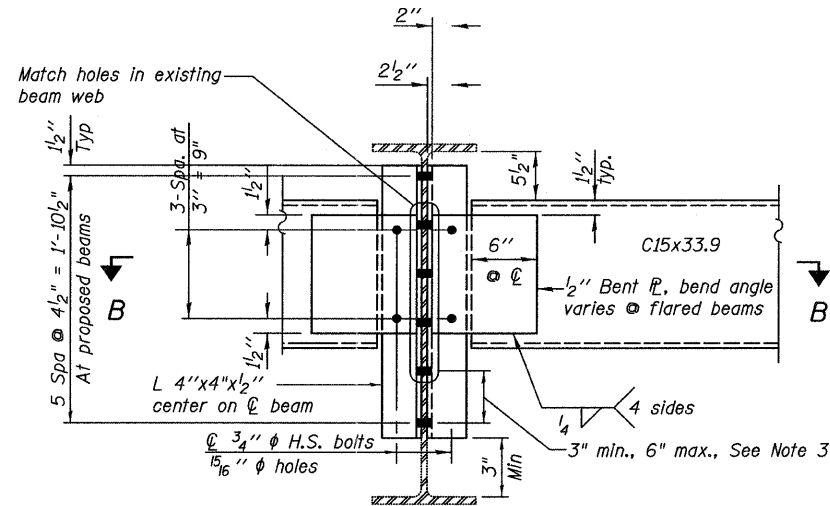

END DIAPHRAGM (D1)

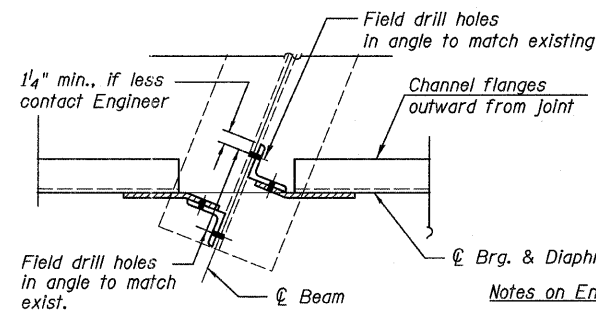

SECTION B-B

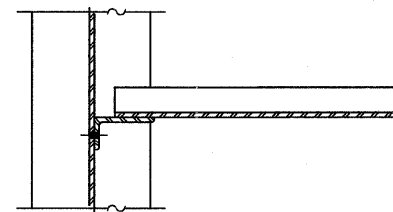

SECTION C-C

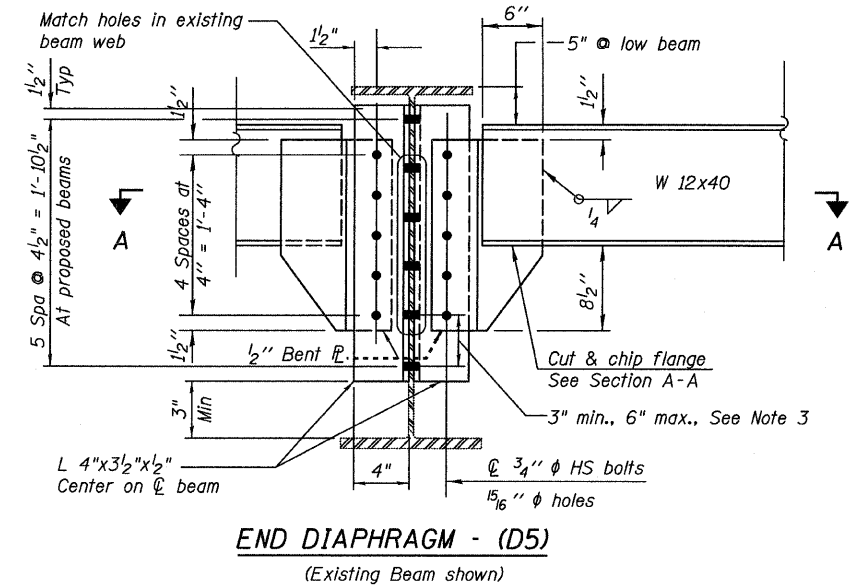

END DIAPHRAGM - (D5)
(Existing Beam shown)

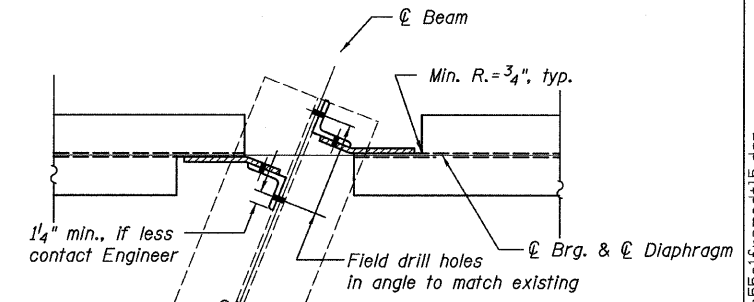

SECTION A-A

Notes on End Diaphragms (D1, D5):

1. The details shown are similar at the proposed beams. Field drilling permitted only at connections to existing beams.
2. Place additional holes in existing beam web as necessary, use 6 bolts minimum.
3. All bolts in beam webs shall be 7/8" H.S. Bolts, 15/16" φ holes.
4. Two hardened washers required for each set of oversized holes.
5. Cost of Field Drilling to be included with the item "Erecting Structural Steel".

Notes on Interior Diaphragms (D2 thru D4):

1. Alternate channels are permitted to facilitate material acquisition. Calculated weight of structural steel is based on the lighter section.
2. The alternate, if utilized, shall be provided at no additional cost to the Department.
3. 3/4" H.S. Bolts, 15/16" φ holes.
4. Two hardened washers required for each set of oversized holes.

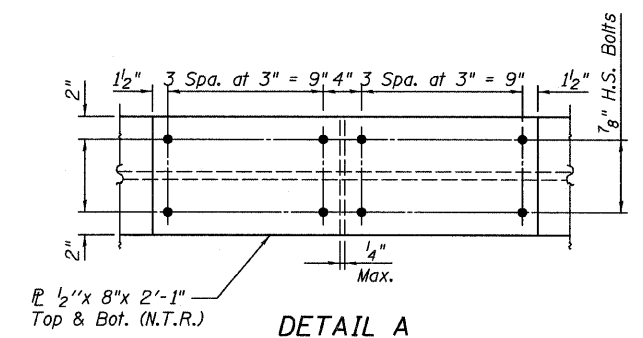

DETAIL A

FRAMING DETAILS I
DIAPHRAGMS
STRUCTURE NO. 016-3241

TYLIN INTERNATIONAL	DESIGNED - JMA	REVISIONS		SHEET NO. 38	F.A.I. RTE.	SECTION	COUNTY	TOTAL SHEETS	SHEET NO.	
	CHECKED - AMD,	NAME	DATE		55	0711.2R & 1011.1BR	COOK	741	291	
	DRAWN - JMA				71 SHEETS	CONTRACT NO. 60999				
	CHECKED - AMD,					FED. ROAD DIST. NO. 1 ILLINOIS FED. AID PROJECT				
	DATE - 03/25/2011									

5/10/2011 4:25:14 PM p:\01345\structure\016-3241\5501\framed\15.dwg