

STATE OF ILLINOIS  
DEPARTMENT OF TRANSPORTATION

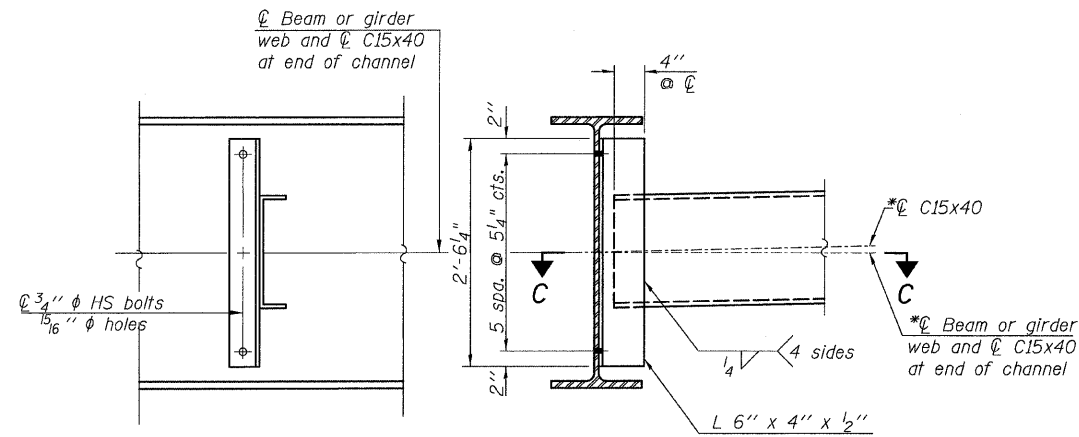

**INTERIOR DIAPHRAGM**  
(D3.2)  
(66 REQUIRED)

Note:  
\*Alternate channels are permitted to facilitate material acquisition. Calculated weight of structural steel is based on the lighter section. The alternate, if utilized, shall be provided at no additional cost to the Department.

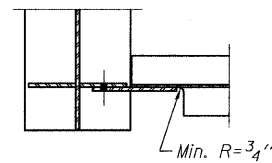
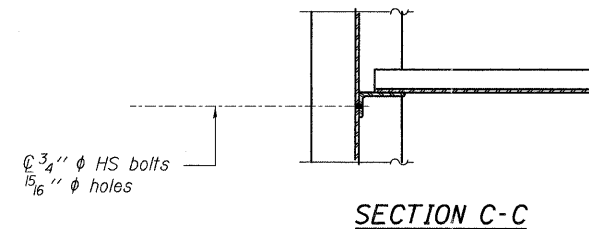

**SECTION A-A**

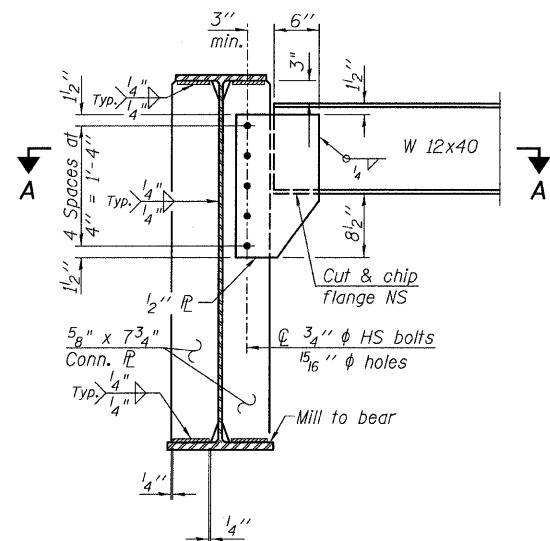

**END DIAPHRAGM**  
(D3.1)  
(6 REQUIRED)

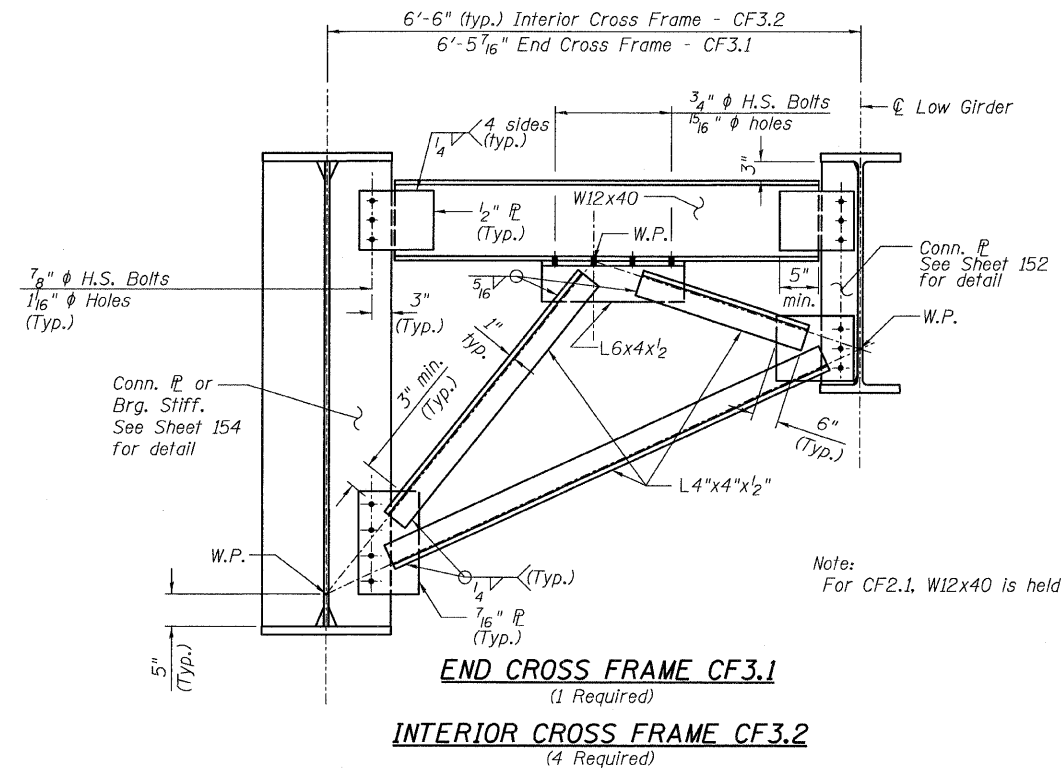

**END CROSS FRAME CF3.1**  
(1 Required)  
**INTERIOR CROSS FRAME CF3.2**  
(4 Required)

Note:  
For CF2.1, W12x40 is held level.

**NOTES:**

- Two hardened washers shall be required over all oversize holes for diaphragms.
- All cross frames or diaphragms shall be installed as steel is erected and secured with erection pins and bolts except as otherwise noted. Individual cross frames or diaphragms at supports may be temporarily disconnected to install bearing anchor rods.
- All bolts shall be 3/4 inch diameter with 15/16 inch diameter holes unless otherwise noted.

**DIAPHRAGMS & DETAILS**  
**RAMP 3 FLARE**  
**STRUCTURE NO. 016-0724**

|                     |                    |           |      |               |   |                    |        |              |           |
|---------------------|--------------------|-----------|------|---------------|---|--------------------|--------|--------------|-----------|
| TYLIN INTERNATIONAL | DESIGNED - MI, DJR | REVISIONS |      | SHEET NO. 168 | F.A.I. RTE.                                     | SECTION            | COUNTY | TOTAL SHEETS | SHEET NO. |
|                     | CHECKED - AMD, MAI | NAME      | DATE |               | 55  | 0711.2R & 1011.1BR | COOK   | 741          | 492       |
|                     | DRAWN - DJR, SB    |           |      |               | 239 SHEETS                                      | CONTRACT NO. 60999 |        |              |           |
|                     | CHECKED - AMD, MAI |           |      |               | FED. ROAD DIST. NO. 1 ILLINOIS FED. AID PROJECT |                    |        |              |           |
|                     | DATE - 03/25/2011  |           |      |               |   |                    |        |              |           |