

STATE OF ILLINOIS
DEPARTMENT OF TRANSPORTATION

STOOL DIMENSIONS

(South Side)		(North Side)	
Stool	Ht. (in)	Stool	Ht. (in)
S-1	12 7/8	S-55	13 3/4
S-2	13 1/4	S-56	13 3/4
S-3	13 5/8	S-57	14 1/8
S-4	8 1/8	S-58	8 1/4
S-5	14 1/4	S-59	14 1/4
S-6	14 3/8	S-60	15 1/8
S-7	14 1/8	S-61	15 1/2
S-8	8 5/8	S-62	8 7/8
S-9	15 1/2	S-63	16 1/4
S-10	15 7/8	S-64	16 1/2
S-11	16 1/8	S-65	16 1/8
S-12	9 1/8	S-66	9 1/4
S-13	16 3/8	S-67	17 3/8
S-14	16 1/8	S-68	17 1/4
S-15	17 1/8	S-69	18
S-16	9 1/4	S-70	9 1/2
S-17	17 5/8	S-71	9 7/8
S-18	17 1/8	S-72	20 1/8
S-19	18 1/8	S-73	19 3/4
S-20	9 1/8	S-74	19 3/8
S-21	20	S-75	9 3/4
S-22	19 3/8	S-76	18 1/4
S-23	19 3/8	S-77	18 1/2
S-24	9 3/4	S-78	18 1/8
S-25	18 1/8	S-79	9 1/2
S-26	18 1/2	S-80	17 1/2
S-27	18 1/4	S-81	17 1/8
S-28	9 1/2	S-82	16 3/4
S-29	17 3/4	S-83	9 3/8
S-30	17 1/2	S-84	16 1/8
S-31	17 1/8	S-85	15 3/4
S-32	9 3/8	S-86	15 3/8
S-33	16 3/8	S-87	9
S-34	16 3/8	S-88	14 5/8
S-35	16	S-89	14 1/8
S-36	9 1/4	S-90	13 3/4
S-37	15 3/8	S-91	8 3/8
S-38	15 1/8	S-92	12 1/8
S-39	14 3/4	S-93	12 1/2
S-40	8 3/4	S-94	12
S-41	14	S-95	7 3/4
S-42	13 5/8	S-96	12 3/8
S-43	13 1/4	S-97	12 1/2
S-44	8 1/4	S-98	12
S-45	12 5/8	S-99	7
S-46	12 1/4	S-100	11
S-47	11 1/8	S-101	10 1/8
S-48	7 1/4		
S-49	11		
S-50	10 5/8		
S-51	6 1/4		
S-52	10 1/8		
S-53	10 1/2		
S-54	6 1/4		

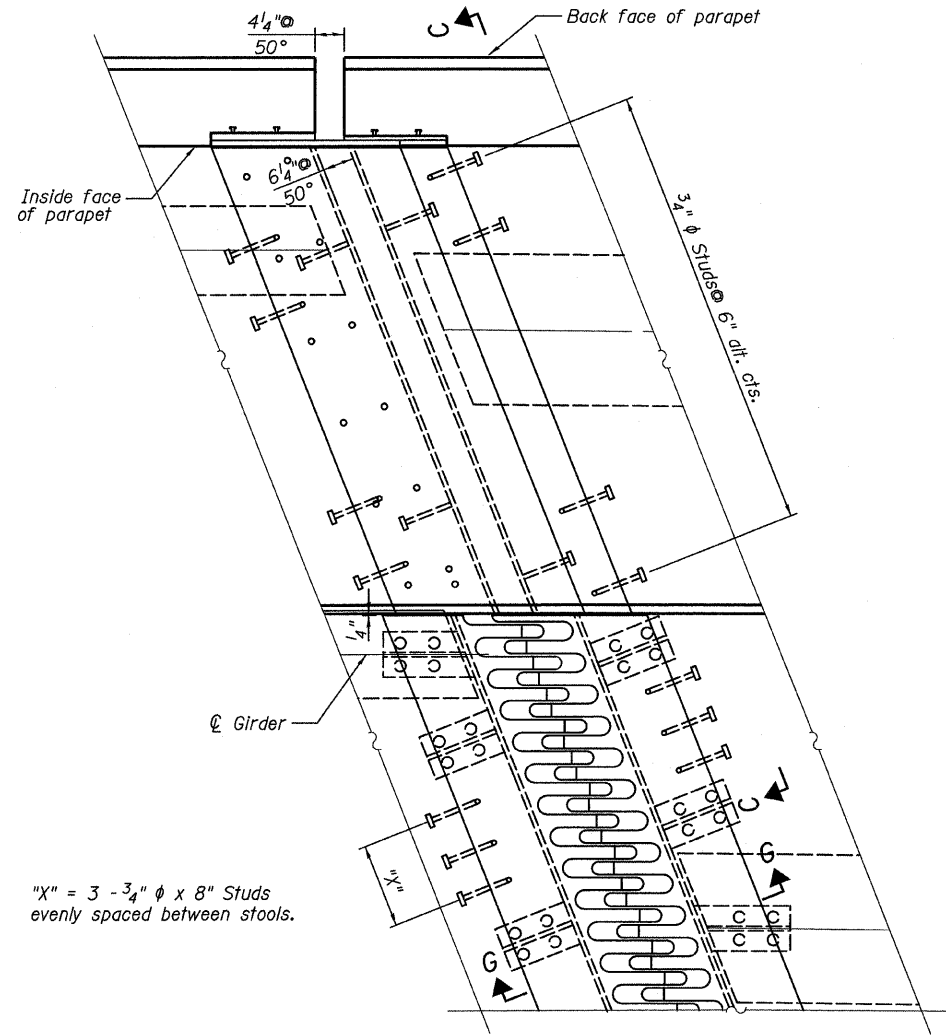

PLAN AT PIER 9
(at 50°)

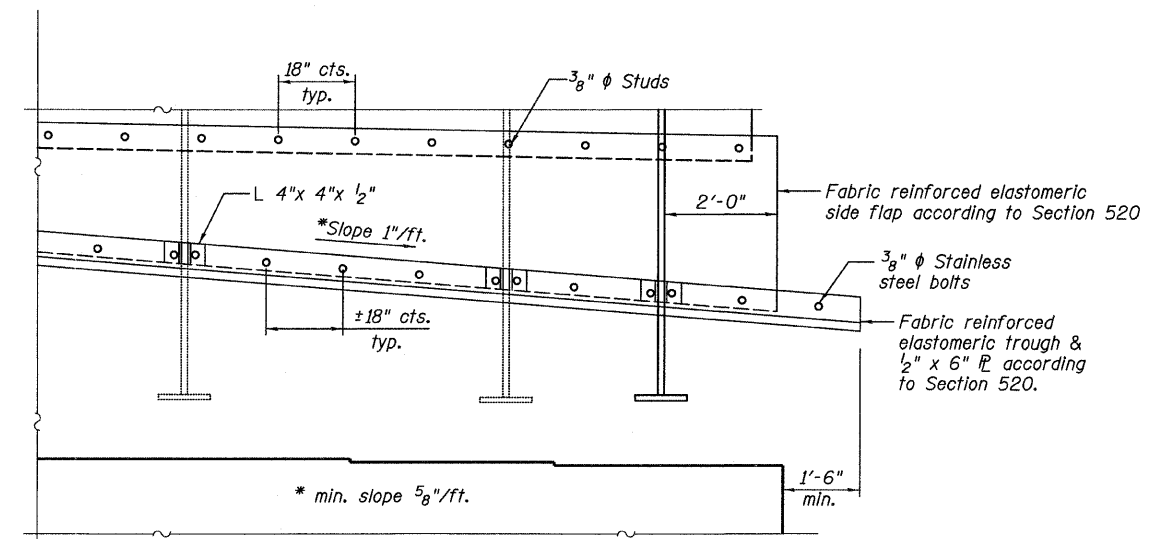

SECTION C-C

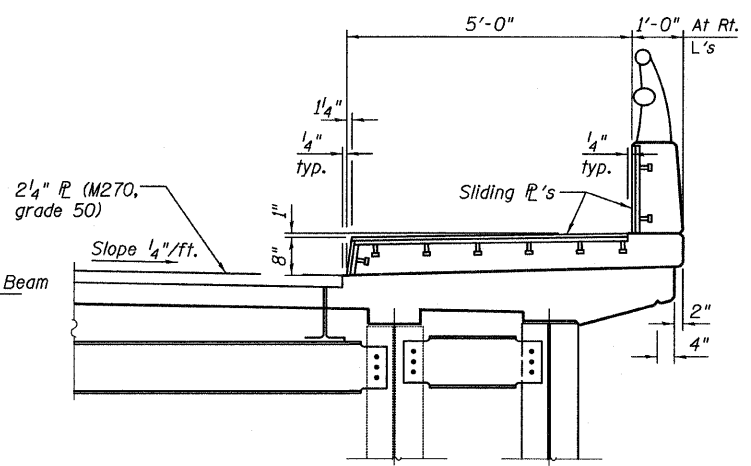

SIDEWALK AND PARAPET
(East Side Looking North - showing sliding plates)

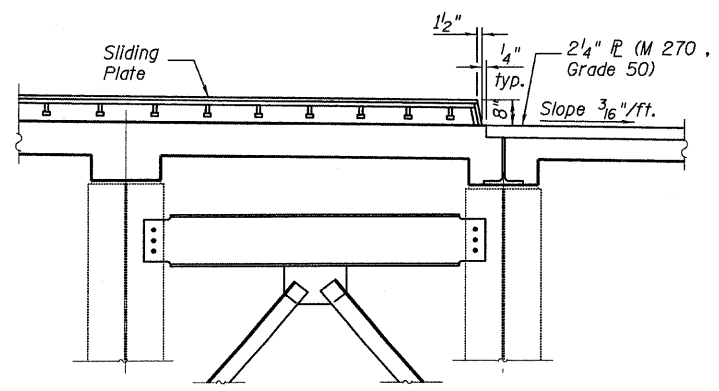

RAISED MEDIAN
(Looking North - Showing Sliding Plates)

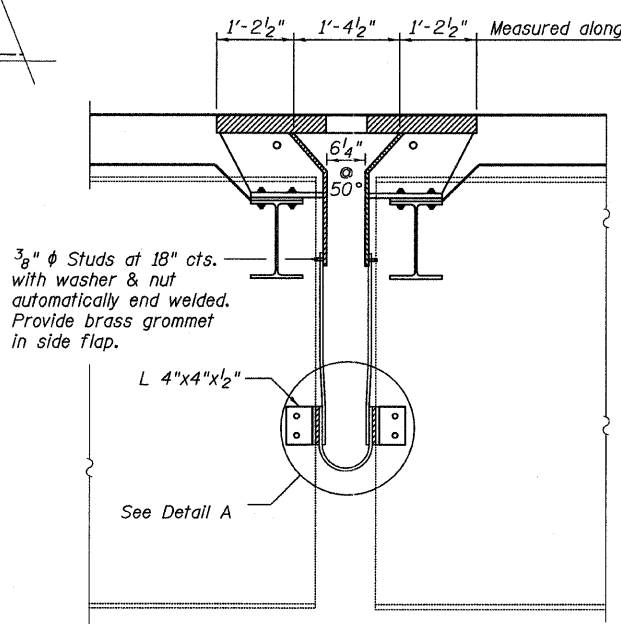

SECTION G-G THRU PIER 9
(Looking West)

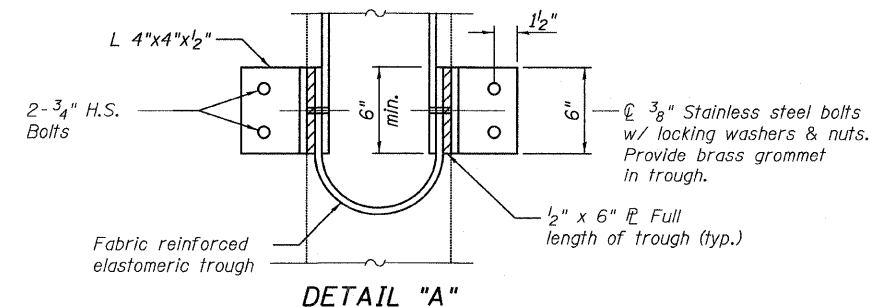

DETAIL "A"

**FINGER PLATE
DETAILS I
STRUCTURE NO. 016-3240**

TYLIN INTERNATIONAL	DESIGNED - DY, LS	REVISIONS		SHEET NO. 31	F.A.I. RTE. 55	SECTION 0711.2R & 1011.1BR	COUNTY COOK	TOTAL SHEETS 741	SHEET NO. 634
	CHECKED - AMD, LS	NAME	DATE						
	DRAWN - DY, LS								
	CHECKED - AMD, LS								
	DATE - 03/25/2011								
				73 SHEETS	FED. ROAD DIST. NO. 1 ILLINOIS		FED. AID PROJECT		