

STA. 200+00 TO STA. 208+00  
**EXISTING TYPICAL SECTION**  
 IL ROUTE 38

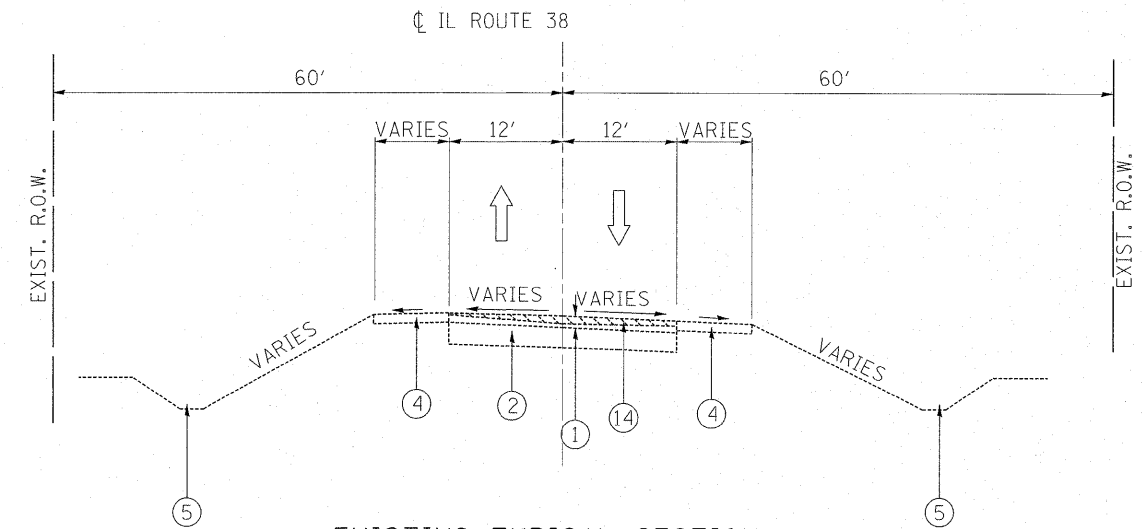

**EXISTING TYPICAL SECTION**  
 IL ROUTE 38

SECTION SUPERELEVATED STA. 208+00 TO STA. 209+50

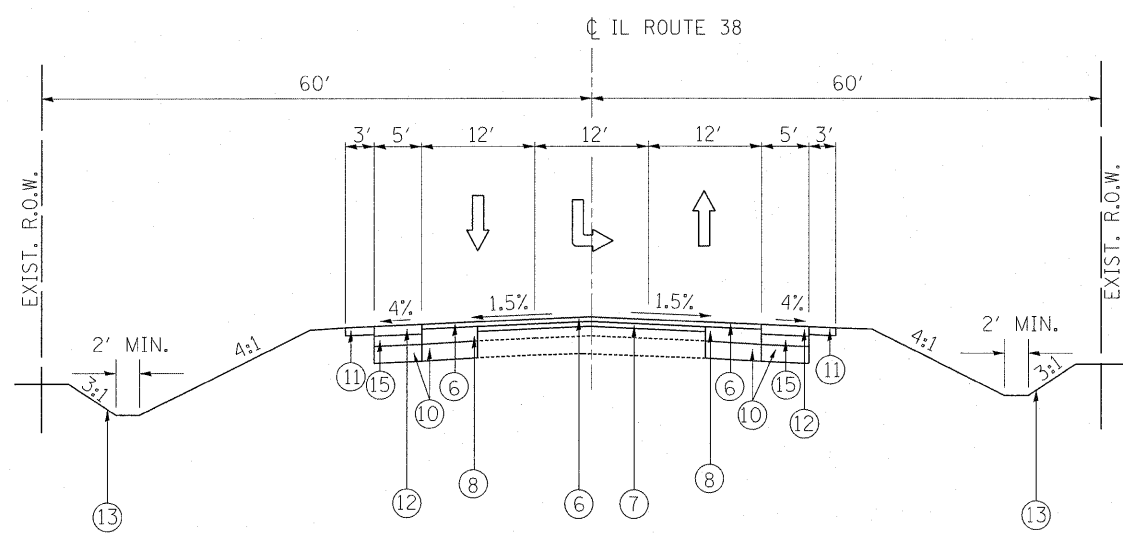

**PROPOSED TYPICAL SECTION**  
 IL ROUTE 38

STA. 200+00 TO STA. 208+00

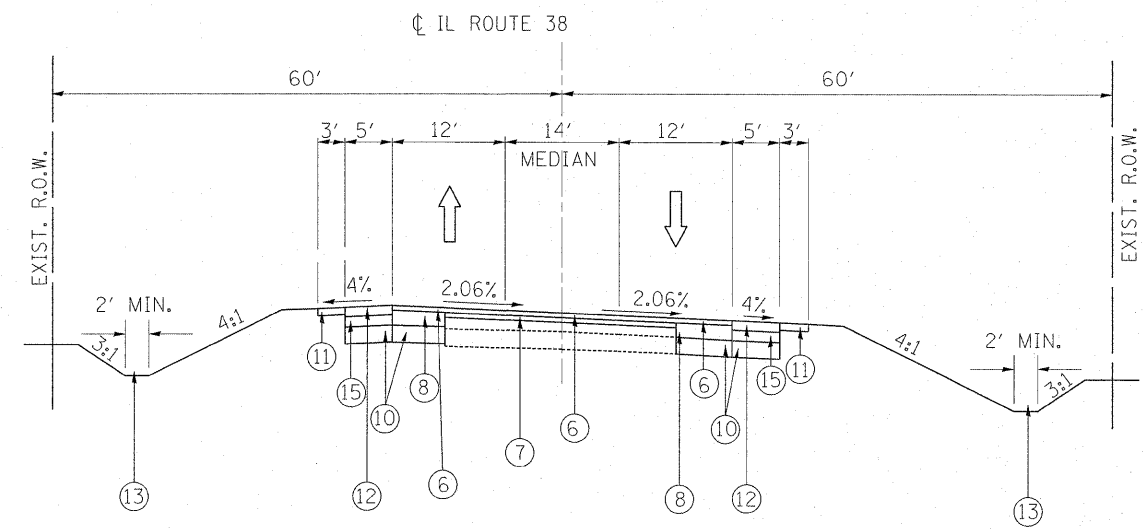

**PROPOSED TYPICAL SECTION**  
 IL ROUTE 38

SECTION SUPERELEVATED STA. 208+00 TO STA. 209+50

FILE NAME =	USER NAME = abraueh	DESIGNED -	REVISED -
et:\pw\work\p15dot\abraueh\d0139632\P115398-Design.dgn		DRAWN -	REVISED -
PLOT SCALE = 50.0000' / IN.		CHECKED -	REVISED -
PLOT DATE = 1/31/2011		DATE -	REVISED -

**STATE OF ILLINOIS**  
**DEPARTMENT OF TRANSPORTATION**

<b>TYPICAL CROSS SECTIONS</b>			
<b>IL. RTE. 38 AT MEREDITH RD.</b>			
SCALE: NONE	SHEET NO.	OF SHEETS	STA. TO STA.

F.A.P. RTE. 567	SECTION 5 R-N-1	COUNTY KANE	TOTAL SHEETS 77	SHEET NO. 6
CONTRACT NO. 60K65				
ILLINOIS FED. AID PROJECT				