

ROUTE FAI 90/94	SECTION 2011-027-1	COUNTY COOK	TOTAL SHEETS 87	SHEET NUMBER 62
--------------------	-----------------------	----------------	--------------------	--------------------

CONTRACT NO. 60P27

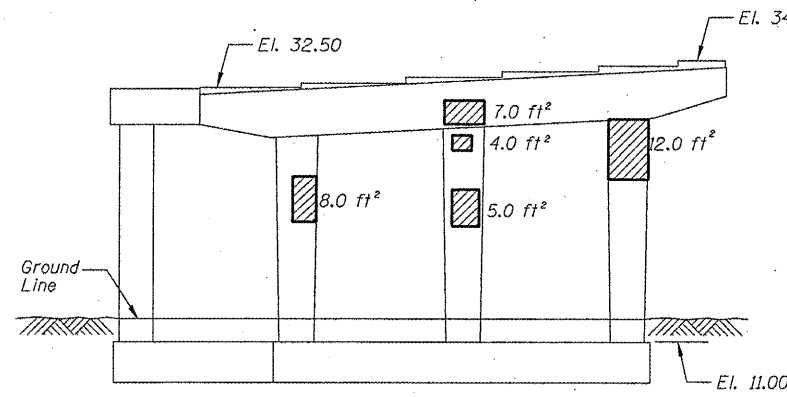

**PIER H7 - ELEVATION**  
(Looking West)

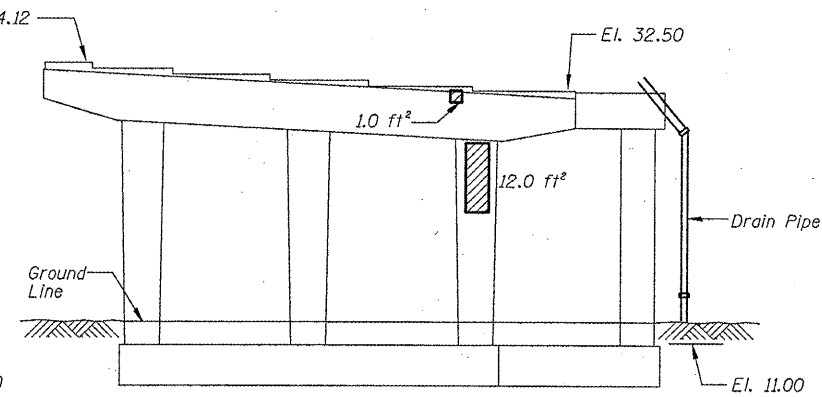

**PIER H7 - ELEVATION**  
(Looking East)

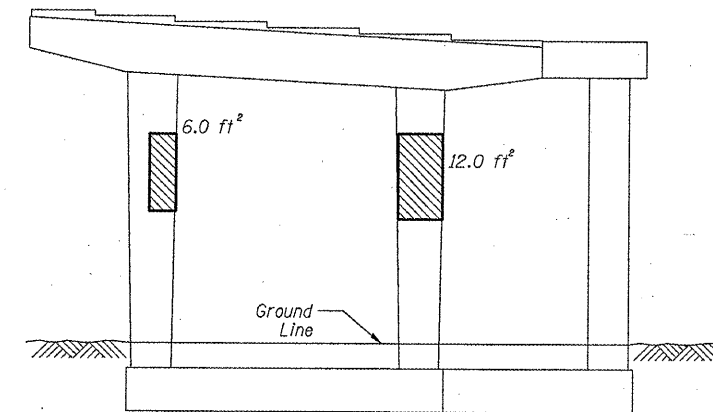

**PIER H9 - ELEVATION**  
(Looking East)

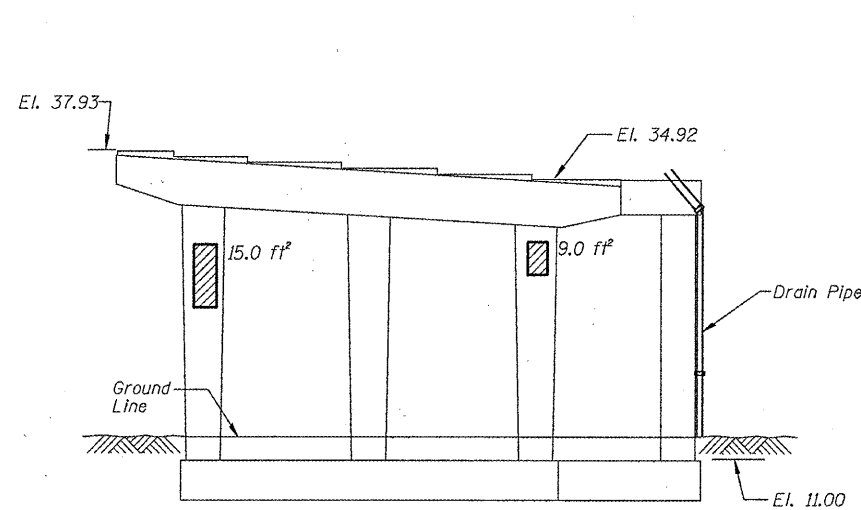

**PIER H8 - ELEVATION**  
(Looking East)

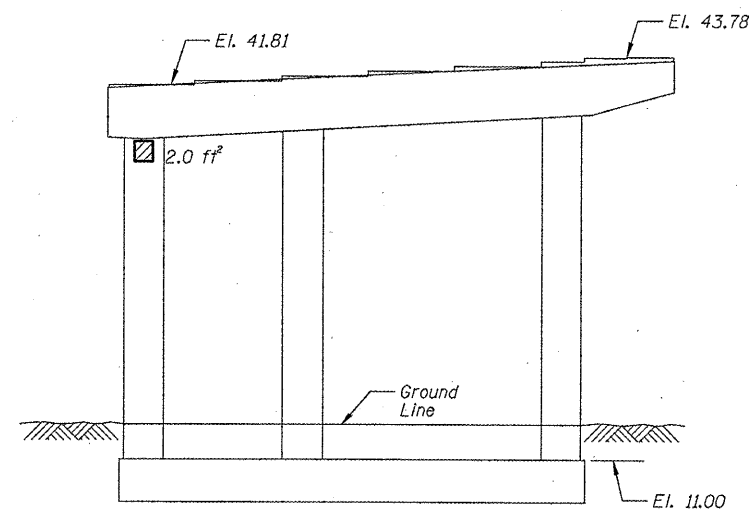

**PIER H11 - ELEVATION**  
(Looking West)

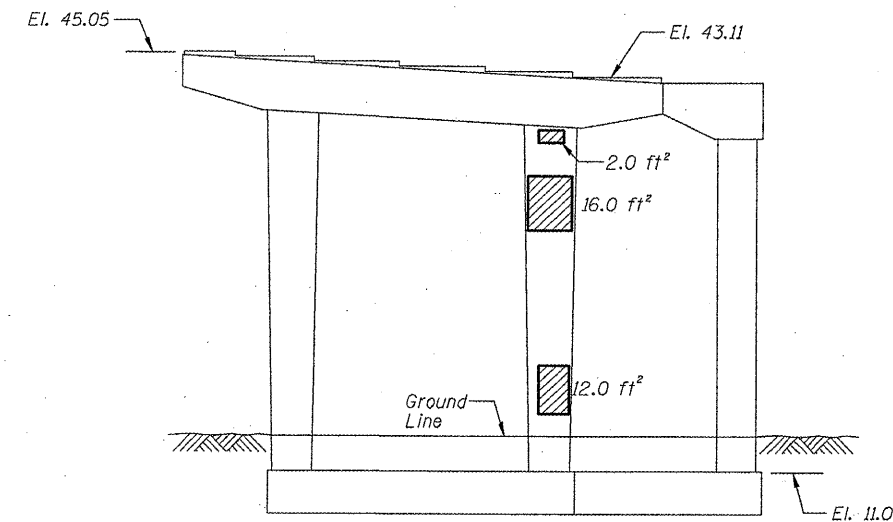

**PIER H12 - ELEVATION**  
(Looking East)

▨ - Structural Repair of Concrete (Depth equal to or less than 5")

**BILL OF MATERIAL**

ITEM	UNIT	QUANTITY
Structural Repair of Concrete (Depth equal to or less than 5")	SQ. FT.	123.0

ILLINOIS DEPARTMENT OF  
TRANSPORTATION

I-90/94 (DAN RYAN EXPRESSWAY)  
SUBSTRUCTURE REPAIRS  
SN 016-1118  
PIERS H7, H8, H9, H11, & H12