

ROUTE FAI 90/94	SECTION 2011-027-I	COUNTY COOK	TOTAL SHEETS 87	SHEET NUMBER 63
--------------------	-----------------------	----------------	--------------------	--------------------

CONTRACT NO. 60P27

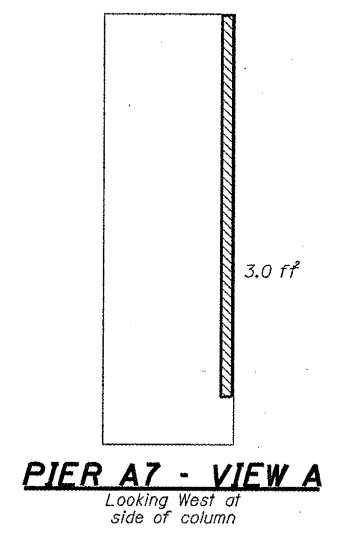

- Structural Repair of Concrete (Depth equal to or less than 5")

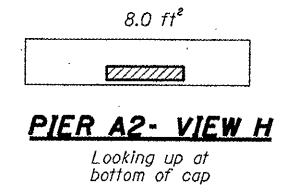
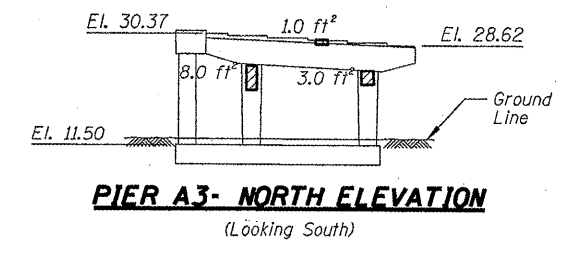
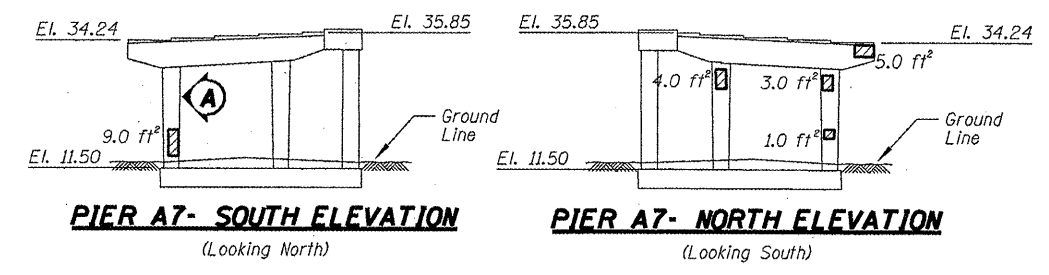
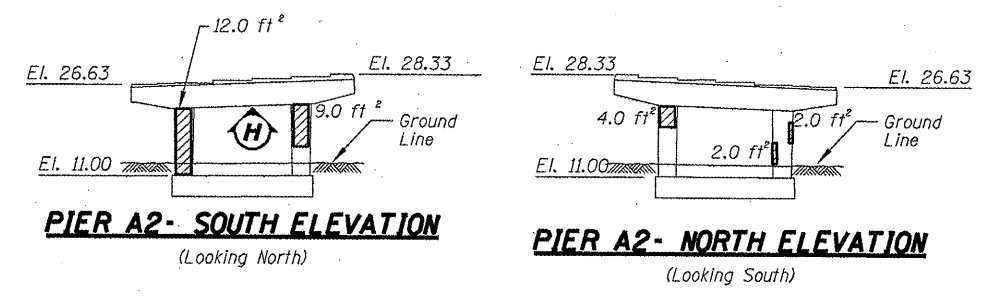
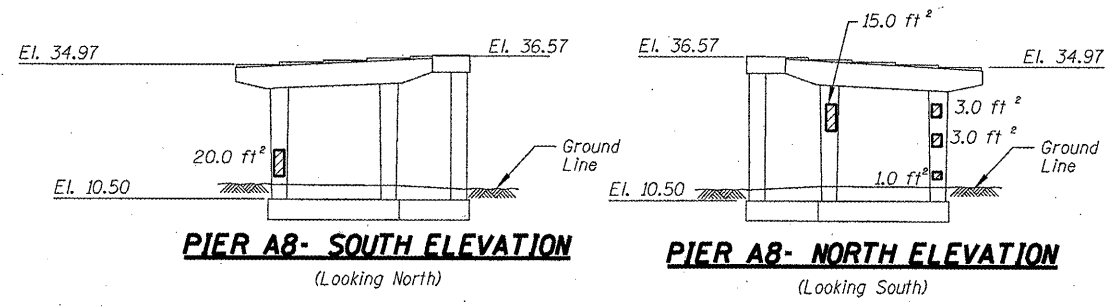

David Carl Puzey 5/13/11
Expires 11/30/2012

BILL OF MATERIAL

ITEM	UNIT	QUANTITY
Structural Repair of Concrete (Depth equal to or less than 5")	SQ. FT.	116.0

ILLINOIS DEPARTMENT OF TRANSPORTATION
I-90/94 (DAN RYAN EXPRESSWAY)
SUBSTRUCTURE REPAIRS
SN 016-1067
PIERS A2, A3, A7, & A8