

ROUTE FAI 90/94	SECTION 2011-027-I	COUNTY COOK	TOTAL SHEETS 87	SHEET NUMBER 67
--------------------	-----------------------	----------------	--------------------	--------------------

CONTRACT NO. 60P27

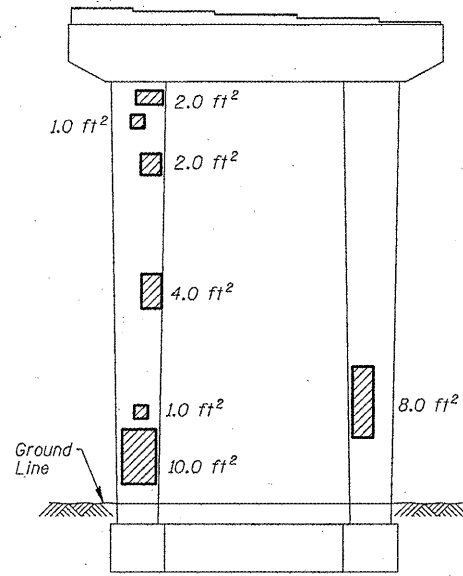

**PIER 53 - WEST ELEVATION**  
(Looking East)

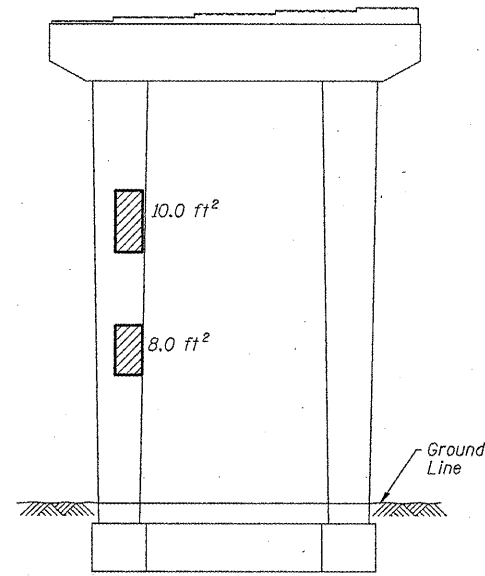

**PIER 53 - EAST ELEVATION**  
(Looking West)

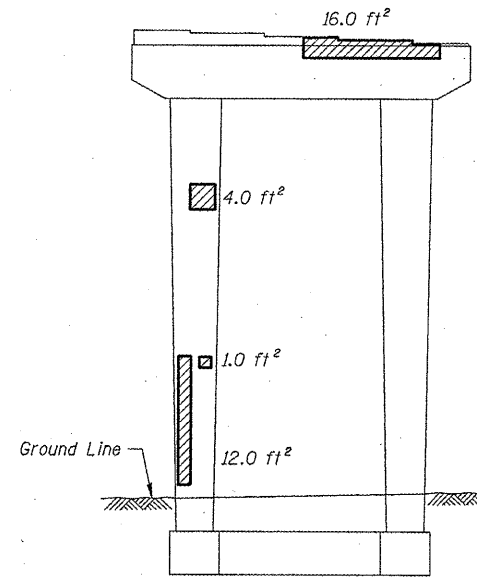

**PIER 51 - WEST ELEVATION**  
(Looking East)

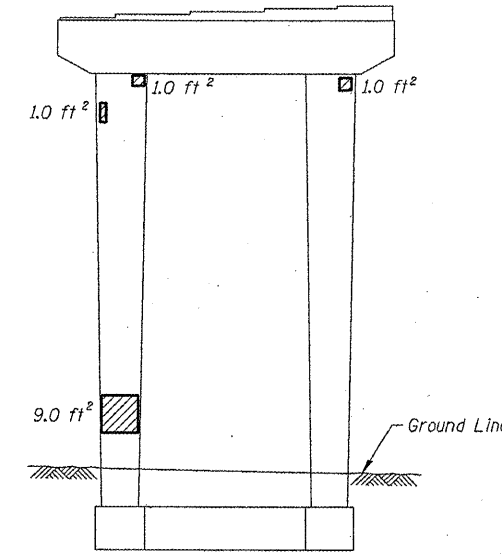

**PIER 51 - EAST ELEVATION**  
(Looking West)

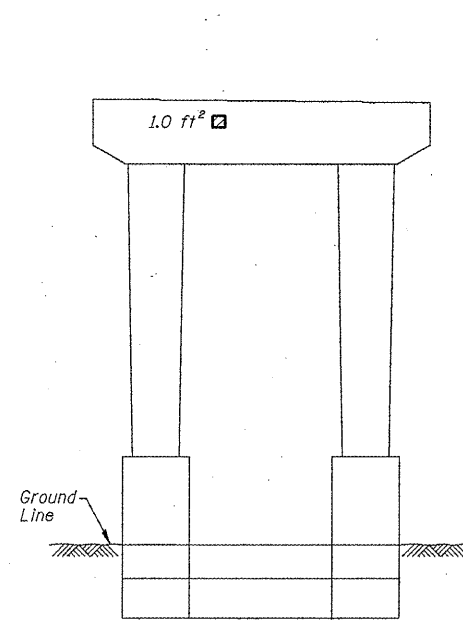

**PIER 52 - WEST ELEVATION**  
(Looking East)

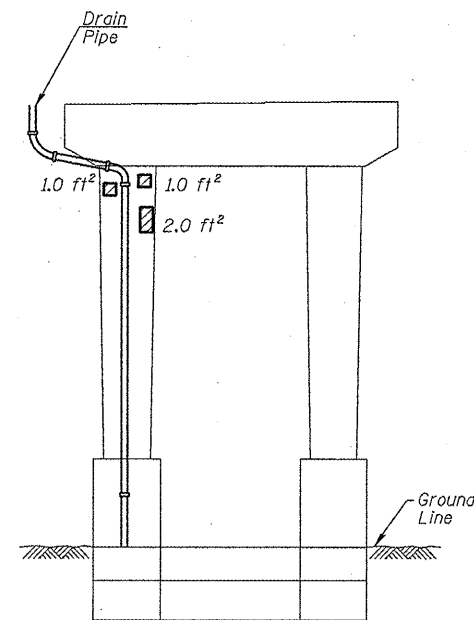

**PIER 52 - EAST ELEVATION**  
(Looking West)

**BILL OF MATERIAL**

ITEM	UNIT	QUANTITY
Structural Repair of Concrete (Depth equal to or less than 5")	SQ. FT.	96.0

▨ - Structural Repair of Concrete (Depth equal to or less than 5")

ILLINOIS DEPARTMENT OF  
TRANSPORTATION

I-90/94 (DAN RYAN EXPRESSWAY)  
SUBSTRUCTURE REPAIRS  
SN 016-1046  
PIERS 51, 52, & 53